

F.A.P. RTE.	SECTION	COUNTY	TOTAL SHEETS	SHEET NO.
808	(3R,3)RS	CHAMPAIGN	47	43

**DETAIL OF PORTLAND CEMENT CONCRETE SURFACE REMOVAL – BUTT JOINT  
MAINLINE**

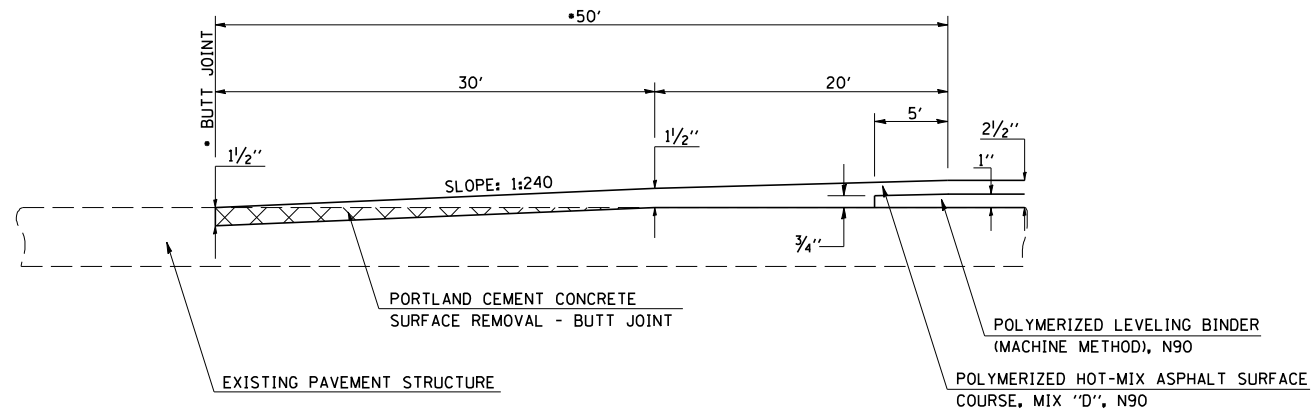

**DETAIL OF PORTLAND CEMENT CONCRETE SURFACE REMOVAL – BUTT JOINT  
SIDEStreETS**

