

F.A.U. RTE.	SECTION	COUNTY	TOTAL SHEETS	SHEET NO.
9177	44-1BR	ST. CLAIR	29	15
STA.		TO STA.		
FED. ROAD DIST. NO.	ILLINOIS	FED. AID PROJECT		

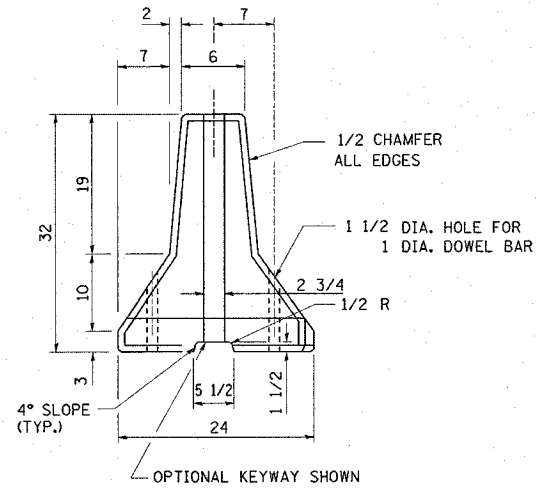

END VIEW
 (WITHOUT WIRE ROPE LOOPS)

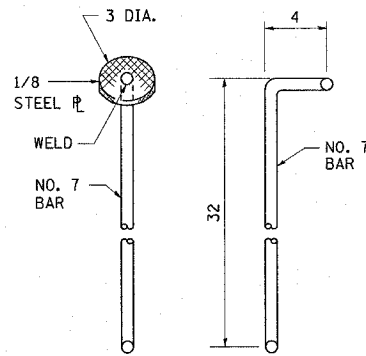

ALTERNATE CONNECTING PINS

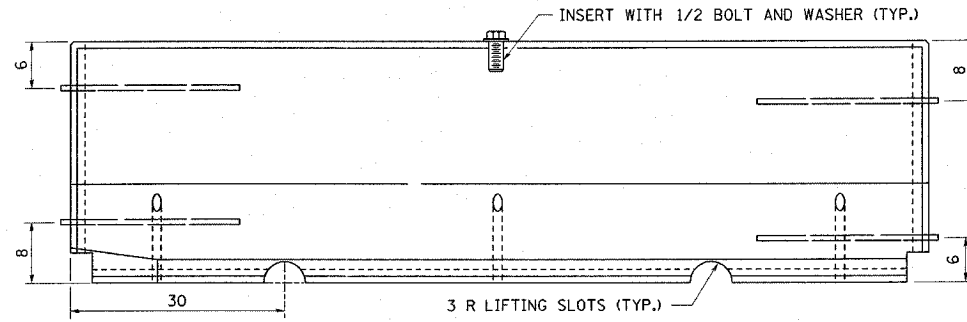

ELEVATION

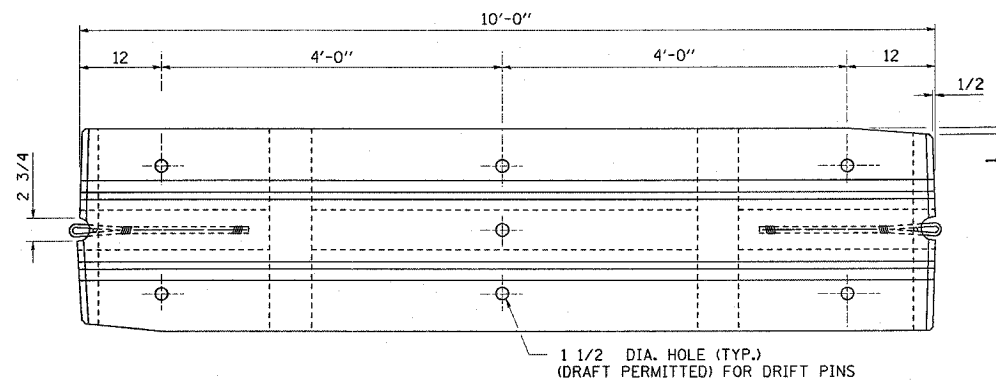

PLAN

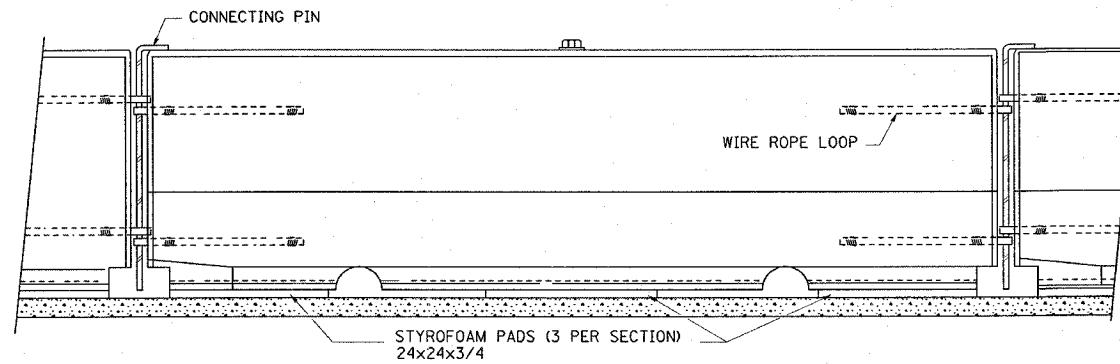

TYPICAL INSTALLATION WITH STYROFOAM PADS

TEMPORARY CONCRETE BARRIER
 NJ SHAPE DESIGN

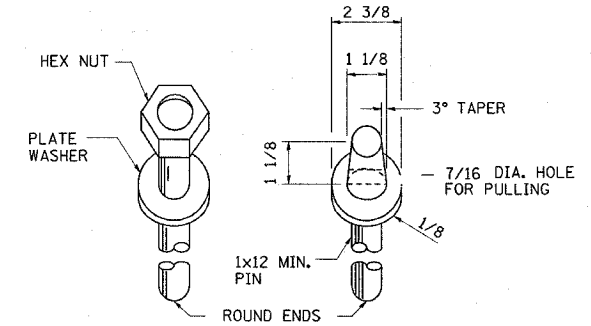

DOWEL BARS

NOTES:
 NEW JERSEY (NJ) SHAPE BARRIER SHALL NOT BE PRODUCED AFTER OCTOBER 1, 2002. HOWEVER, NEW JERSEY SHAPE BARRIER PRODUCED PRIOR TO OCTOBER 1, 2002 MAY BE USED UNTIL JANUARY 1, 2008.

THE NJ SHAPE BARRIER UNITS SHALL BE SEATED ON STYROFOAM PADS EXCEPT WHEN THEY ARE ANCHORED.

NJ SHAPE DOWEL BARS SHALL BE EMBEDDED AT LEAST 8 INCHES INTO THE PAVEMENT, AND SHALL NOT PROJECT ABOVE THE OUTER SURFACE OF THE BARRIER. THE CONNECTING PIN FOR THE NJ SHAPE PIN AND LOOP CONNECTION, MAY BE EITHER A PLAIN 7/8 INCH DIAMETER OR A DEFORMED NO. 7 BAR MEETING THE REQUIREMENTS OF ARTICLE 1006.10(b) EXCEPT GRADE 60 BARS SHALL BE USED.

ALL DIMENSIONS ARE IN INCHES UNLESS OTHERWISE SHOWN.

REVISIONS	
NAME	DATE

ILLINOIS DEPARTMENT OF TRANSPORTATION

MISCELLANEOUS DETAILS

FAU ROUTE 9177
 SECTION 44-1BR
 ST. CLAIR COUNTY