

**ELEVATION**  
(West Abutment)

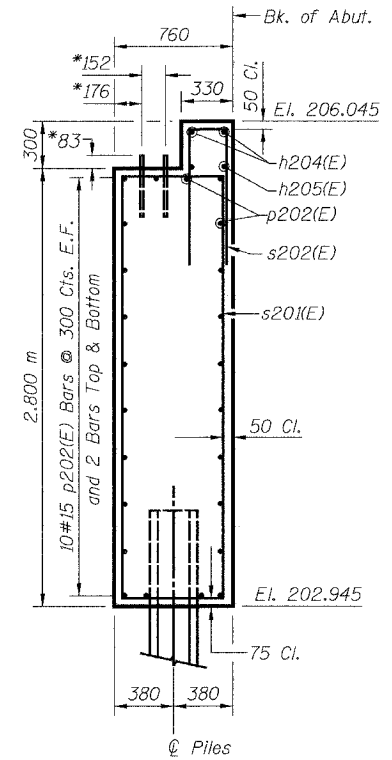

**SECTION A-A**

**BILL OF MATERIAL**

Bar	No.	Size	Length	Shape
h204(E)	2	#15	7.78 m	
h205(E)	2	#15	6.07 m	
h206(E)	40	#15	2.41 m	
p202(E)	24	#15	4.55 m	
s201(E)	14	#15	6.94 m	
s202(E)	16	#15	2.53 m	
v202(E)	12	#15	5.39 m	
Concrete Structures			Cu. M	13.2
Reinforcement Bars, Epoxy Coated			kg	690
Furnishing Steel Piles HP310x79			Meter	38
Driving Steel Piles			Meter	38
Test Pile Steel HP310x79			Each	1
Metal Shoes			Each	2
Structure Excavation			Cu. M	20.9

**LEGEND**

E.F. = Each Face

**MIN. BAR LAP**

#15 = 890

**PILE DATA:**

Type: HP310x79  
 Capacity: Driven to Refusal  
 Est. Length: 19.0 m  
 No. Required: 2 + 1 Test Pile  
 (Test Pile shall be a permanent pile driven at the West Abutment)

\* Anchor bolt size and locations shall be checked against the Bridge Fabricator's requirements prior to setting them.

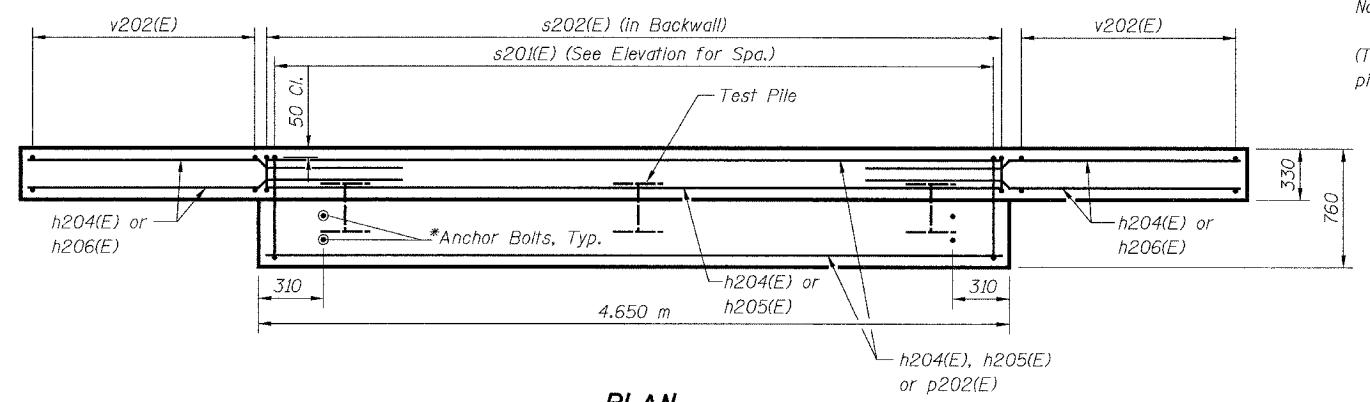

**PLAN**  
(West Abutment)

**NOTES:**

- Space reinforcement in cap to miss anchor bolts.
- All edges shall have standard 20 mm chamfers except as noted.
- For Anchor Bolt Details, see Sheet S27.
- There shall be no splicing of longitudinal bars. Bars shall be ordered full length.
- Bars designated (E) shall be epoxy coated.

SHEET S9 of S28

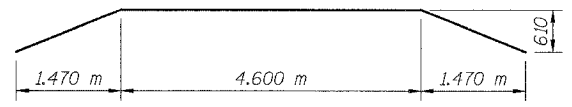

**BAR h204(E)**

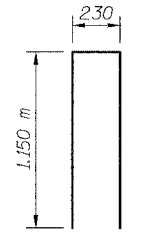

**BAR s202(E)**

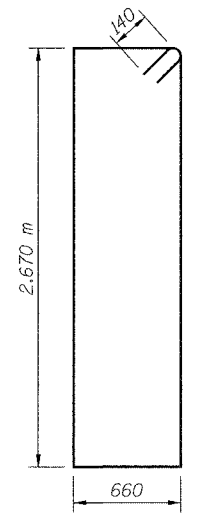

**BAR s201(E)**

REVISIONS		1701 GOLF ROAD, SUITE 1000 ROLLING MEADOWS, IL 60008 TEL (847) 228-0707 FAX (847) 228-1115
NAME	DATE	
		VILLAGE OF ADDISON SALT CREEK GREENWAY TRAIL PEDESTRIAN BRIDGE, STA. 12+535.5 WEST ABUTMENT DETAILS

DATE: 11/03/04  
 DESIGNED BY: MDS  
 DRAWN BY: MDS  
 CHECKED BY: GAT