

STATE OF ILLINOIS
DEPARTMENT OF TRANSPORTATION
DIVISION OF HIGHWAYS
**PLANS FOR PROPOSED
FEDERAL AID PROJECT**

SECTION	COUNTY	TOTAL SHEETS	SHEET NO.
02-00034-00-BT	DU PAGE	108	1

CONTRACT NO. 83714

SALT CREEK GREENWAY TRAIL (SOUTH DUPAGE)
PROJECT LIMITS: 2nd STREET TO DUPAGE COUNTY LINE
SCOPE OF WORK: BIKE TRAIL
PROJECT NO. M-8003(216)
SECTION NO. 02-00034-00-BT
VILLAGE OF OAK BROOK
DUPAGE COUNTY
C-91-278-02

INDEX OF SHEETS

- 1 TITLE SHEET / INDEX OF SHEETS
- 2 STATE STANDARDS, PLAN NOTES
- 3-5 SUMMARY OF QUANTITIES
- 6-7 TYPICAL SECTIONS
- 8 TREE REMOVAL SCHEDULE
- 9-26 PLAN AND PROFILE
- 27-30 MISC. DETAILS
- 31 WETLAND PLAN
- 32-35 DISTRICT 1 DETAILS
- 36-69 STRUCTURE PLANS
- 70-108 CROSS SECTIONS

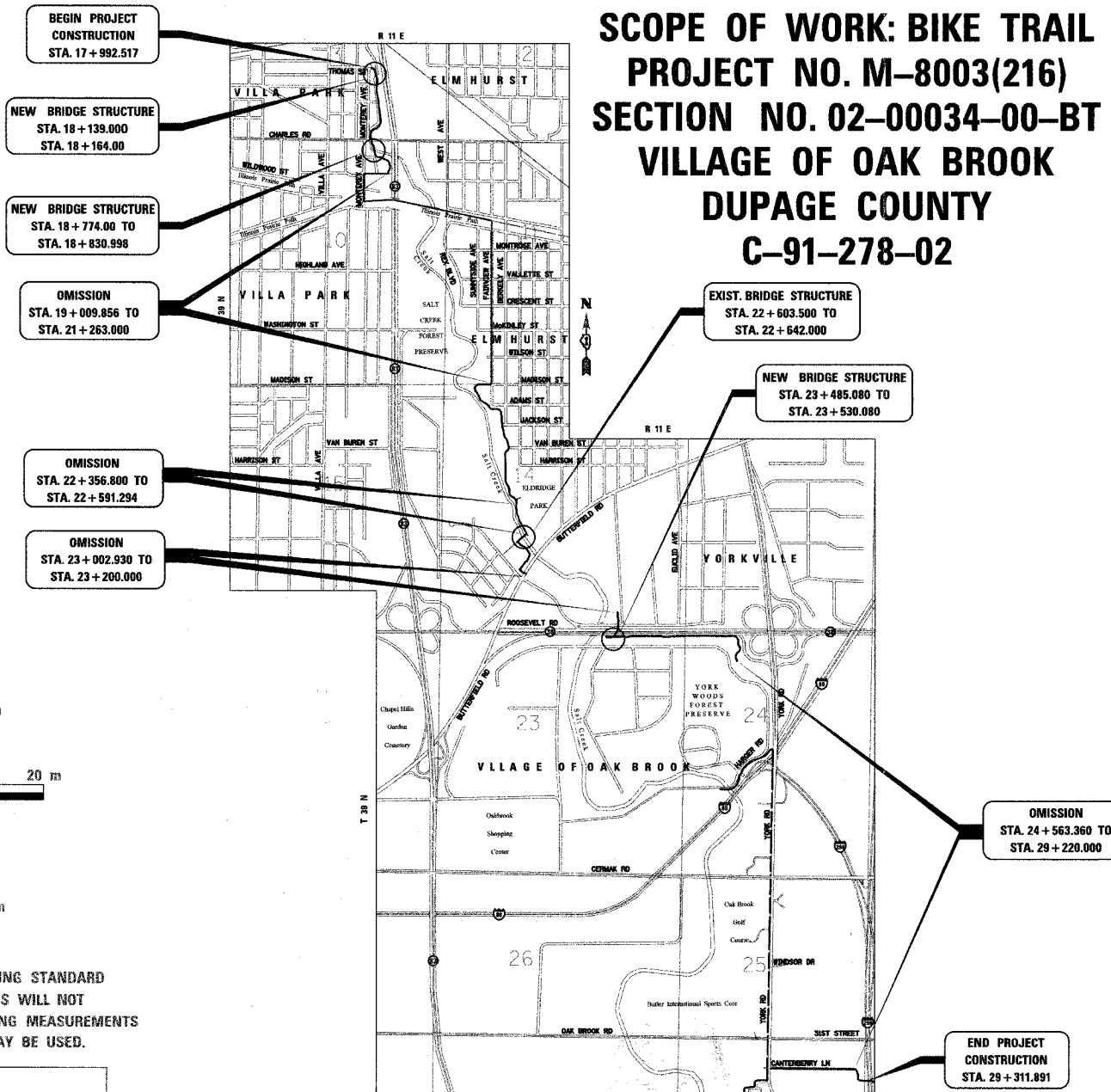

METRIC RATIOS

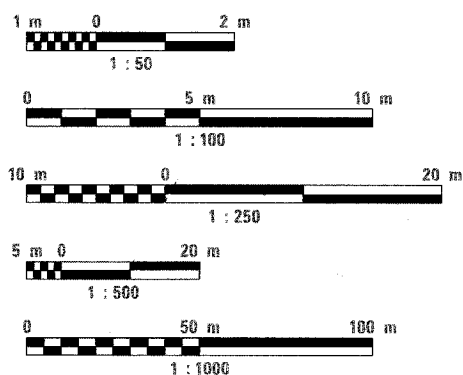

FULL SIZE PLANS HAVE BEEN PREPARED USING STANDARD ENGINEERING SCALES. REDUCED SIZED PLANS WILL NOT CONFORM TO STANDARD SCALES. IN MAKING MEASUREMENTS ON REDUCED PLANS, THE ABOVE SCALES MAY BE USED.

J.U.L.I.E.
JOINT UTILITY LOCATION INFORMATION FOR EXCAVATION
1-800-892-0123

CONTRACT NO. 83714

LOCATION MAP
SCALE 1:1200

GROSS PROJECT LENGTH : 11,319.374 METERS
NET PROJECT LENGTH : 3,978.026 METERS

DESIGN DESIGNATION

BIKE PATH

VILLAGE OF OAK BROOK
APPROVED July 18, 2005
David R. Ruffolo
VILLAGE ENGINEER

STATE OF ILLINOIS
DEPARTMENT OF TRANSPORTATION
DIVISION OF HIGHWAYS
APPROVED 7/21 2005
Chris
LOCAL ROADS AND STREET ENGINEER
APPROVED July 21, 2005
Dina O'Keefe
DEPUTY DIRECTOR OF HIGHWAYS, REGION ENGINEER

**PRINTED BY THE AUTHORITY
OF THE STATE OF ILLINOIS**

PLANS PREPARED BY:
URS 1701 GOLF ROAD, SUITE 1000
ROLLING MEADOWS, IL 60008
TEL. (847) 228-0707
FAX (847) 228-1115



DATE: 7/20/05
Expire: 11/30/05

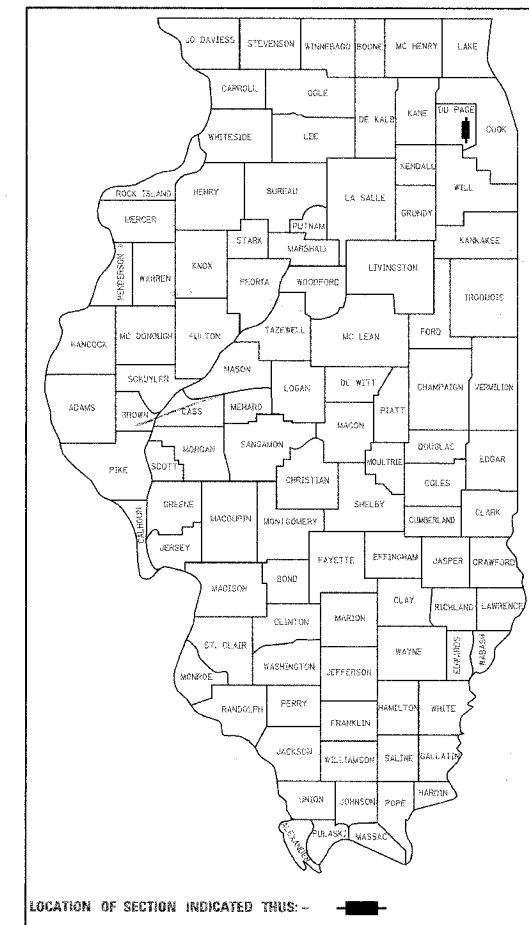

FEDERAL AID PROGRAM ENGINEER: CHARLES RIDDLE, P.E. (847) 705-4406

PLAN NOTES

SECTION	COUNTY	TOTAL SHEETS	SHEET NO.
02-00034-00-BT	DUPAGE	108	2
STA.	TO STA.		
IDOT PROJECT NO. M-8003(216)			
SALT CREEK GREENWAY TRAIL			

GENERAL NOTES BEFORE STARTING ANY EXCAVATION, THE CONTRACTOR SHALL CALL "JULIE" AT 800-892-0123 FOR FIELD LOCATIONS OF BURIED UTILITY FACILITIES. (48 HOURS NOTIFICATION IS REQUIRED).

ALL STATION-OFFSET CALL OUTS AND CURVE DATA ON THE PLANS REFER TO THE PROPOSED CENTERLINE UNLESS OTHERWISE SHOWN.

IT IS THE CONTRACTORS RESPONSIBILITY TO VERIFY ALL DIMENSIONS

SPECIFICATIONS ALL CONSTRUCTION SHALL BE DONE IN ACCORDANCE WITH THE "STANDARD SPECIFICATIONS FOR ROAD AND BRIDGE CONSTRUCTION", ADOPTED JANUARY 1, 2002, THE "STANDARD SPECIFICATIONS FOR WATER AND SEWER MAIN CONSTRUCTION IN ILLINOIS", MAY 1996 EDITION, THE "MANUAL ON UNIFORM TRAFFIC CONTROL DEVICES FOR STREETS AND HIGHWAYS", LATEST EDITION, THE DETAILS INCLUDED IN THE PLANS, AND THE SPECIAL PROVISIONS INCLUDED IN THE CONTRACT DOCUMENTS.

STANDARDS ANY REFERENCE TO "STANDARDS" THROUGHOUT THE PLANS OR SPECIAL PROVISIONS SHALL BE INTERPRETED TO BE THE LATEST STANDARD OF IDOT AS LISTED ON THIS SHEET.

COORDINATION THE CONTRACTOR SHALL NOTIFY THE CITY OF ELMHURST, ELMHURST PARK DISTRICT, THE VILLAGE OF VILLA PARK, THE VILLAGE OF OAK BROOK AND THE FOREST PRESERVE DISTRICT OF DUPAGE COUNTY AT LEAST 48 HOURS IN ADVANCE OF BEGINNING WORK, AND SHALL COORDINATE ALL CONSTRUCTION OPERATIONS WITH THE ENGINEER.

PUBLIC OR PRIVATE UTILITIES THE LOCATIONS OF PUBLIC OR PRIVATE UTILITIES SHOWN ON THE PLANS ARE APPROXIMATE, AND THE DISTRICT DOES NOT GUARANTEE THEIR ACCURACY. THE CONTRACTOR WILL BE REQUIRED TO ASCERTAIN THE EXACT LOCATIONS OF SUCH UTILITIES AND EXERCISE CARE DURING CONSTRUCTION OPERATIONS SO AS NOT TO DAMAGE THEM, IN ACCORDANCE WITH THE SPECIAL PROVISIONS AND ARTICLE 107.20 OF THE "STANDARD SPECIFICATIONS". THE CONTRACTOR SHALL BE RESPONSIBLE FOR CONTACTING THE UTILITY OWNERS SO THAT THEIR FACILITIES MAY BE ADJUSTED OR RELOCATED, IF NECESSARY, PRIOR TO THE START OF CONSTRUCTION OPERATIONS UNLESS OTHERWISE NOTED IN THE PLANS. ALL RELOCATION WORK ON EXISTING PRIVATE UTILITIES WILL BE CONSTRUCTED BY THE OWNER OF THAT UTILITY.

THE CONTRACTOR SHALL BE RESPONSIBLE FOR ANY DAMAGE OR DESTRUCTION OF PUBLIC OR PRIVATE PROPERTY, AND SHALL RESTORE SUCH PROPERTY AT HIS/HER OWN EXPENSE.

SURVEY MONUMENTS THE CONTRACTOR SHALL PROTECT AND CAREFULLY PRESERVE ALL SECTION OR SUBSECTION MONUMENTS OR PROPERTY OR REFERENCE MARKERS UNTIL THE OWNER, HIS AGENT OR AN AUTHORIZED SURVEYOR HAS WITNESSED OR OTHERWISE REFERENCED THEIR LOCATIONS.

WHERE SECTION OR SUBSECTION MONUMENTS ARE ENCOUNTERED, THE ENGINEER SHALL BE NOTIFIED BEFORE MONUMENTS ARE REMOVED.

DISPOSAL OF MATERIALS THE CONTRACTOR WILL BE REQUIRED TO DISPOSE OF ALL SIDEWALK, CURB AND GUTTER, PAVEMENT, AND ALL OTHER MATERIALS EXCAVATED OR REMOVED DUE TO CONSTRUCTION OPERATIONS, AT HIS EXPENSE. NO PAYMENT WILL BE MADE FOR HAULING OR TRUCKING MATERIAL TO LOCATIONS, PROVIDED BY THE CONTRACTOR, OUTSIDE THE LIMITS OF THE IMPROVEMENT.

EXISTING DRAINAGE STRUCTURES DURING CONSTRUCTION OPERATIONS, WHENEVER ANY LOOSE MATERIAL IS DEPOSITED IN THE FLOW LINE OF DRAINAGE STRUCTURES, SUCH THAT THE NATURAL FLOW OF WATER IS OBSTRUCTED, IT SHALL BE REMOVED BY THE CONTRACTOR AT THE CLOSE OF EACH WORKING DAY. AT THE CONCLUSION OF CONSTRUCTION OPERATIONS, ALL DRAINAGE STRUCTURES SHALL BE FREE FROM DIRT AND DEBRIS. THE WORK SPECIFIED ABOVE WILL NOT BE PAID FOR SEPARATELY, BUT SHALL BE CONSIDERED AS INCIDENTAL TO THE CONTRACT.

WHEN EXISTING DRAINAGE FACILITIES ARE DISTURBED, THE CONTRACTOR SHALL PROVIDE AND MAINTAIN TEMPORARY OUTLETS AND CONNECTIONS FOR ALL PRIVATE OR PUBLIC DRAINS, SEWERS OR CATCH BASINS. HE SHALL PROVIDE FACILITIES TO TAKE IN ALL STORM WATER WHICH WILL BE RECEIVED BY THESE DRAINS AND SEWERS, AND DISCHARGE SAME. HE SHALL PROVIDE AND MAINTAIN AN EFFICIENT PUMPING PLANT, IF NECESSARY, AND A TEMPORARY OUTLET, AND BE PREPARED AT ALL TIMES TO DISPOSE OF THE WATER RECEIVED FROM THESE TEMPORARY CONNECTIONS UNTIL SUCH TIME AS THE PERMANENT CONNECTIONS WITH SEWERS ARE BUILT AND IN SERVICE. THIS WORK WILL NOT BE PAID FOR DIRECTLY, BUT SHALL BE CONSIDERED INCIDENTAL TO THE CONTRACT.

UNSUITABLE MATERIAL BEFORE REMOVAL OF ANY UNSUITABLE MATERIAL, THE CONTRACTOR SHALL TREAT THE SUBGRADE AS PER ARTICLE 301.03 OF THE "STANDARD SPECIFICATIONS" TO THE SATISFACTION OF THE ENGINEER. UNSUITABLE MATERIAL SHALL NOT BE USED AS EMBANKMENT OR FILL UNDER THE PROPOSED PATH AS SHOWN ON THE TYPICAL CROSS SECTIONS.

FLOODPLAIN MANAGEMENT

THE COMPENSATORY STORAGE SHALL BE PROVIDED AND OPERATED PRIOR TO PLACEMENT OF THE FILL, STRUCTURES OR OTHER MATERIALS IN THE REGULATORY FLOODPLAIN.

CONSTRUCTION ACCESS LOCATIONS

THE CONSTRUCTION ACCESS LOCATIONS SHALL AVOID WETLAND, WETLAND BUFFER AND RIPARIAN AREAS.

STOCKPILES STOCKPILES OF TOPSOIL AND OTHER MATERIALS SHALL NOT BE LOCATED WITHIN A SPECIAL MANAGEMENT AREA. APPROVAL OF THE LOCATION MUST BE OBTAINED FROM THE ENGINEER PRIOR TO PLACEMENT. IF A STOCKPILE IS TO REMAIN IN PLACE FOR MORE THAN THREE DAYS, THE EROSION CONTROL MEASURES SHALL BE PROVIDED.

TREE TRIMMING ALL BRANCHES THAT ARE LESS THAN 12 FEET ABOVE THE SURFACE OF THE TRAIL SHALL BE REMOVED BY A CERTIFIED ARBORIST. THIS WORK WILL BE PAID FOR AS PRUNING FOR SAFETY AND EQUIPMENT CLEARANCE.

ACCESS TO ABUTTING PROPERTY THE CONTRACTOR SHALL MAINTAIN ACCESS TO ABUTTING PROPERTY DURING THE CONSTRUCTION OF THIS PROJECT, EXCEPT FOR PERIODS OF SHORT DURATION AS APPROVED BY THE ENGINEER.

SAW CUTTING THE LIMITS OF REMOVAL OF ALL CONCRETE OR BITUMINOUS PAVEMENTS, CURBING OR SIDEWALK ADJACENT TO EXISTING LIKE PAVEMENTS, CURBING OR SIDEWALKS SHALL BE SAWCUT IN ACCORDANCE WITH SECTION 440 OF THE "STANDARD SPECIFICATIONS" AND AT THE DIRECTION OF THE ENGINEER. THE SAW CUTTING OF BITUMINOUS PAVEMENT, DRIVEWAYS, CURBING OR SIDEWALK SHALL BE CONSIDERED INCIDENTAL TO THE CONTRACT AND WILL NOT BE PAID FOR AS SEPARATE ITEMS.

ADJACENT PAVEMENT OR SIDEWALK DISTURBED DURING CONSTRUCTION SHALL BE RESTORED TO THE ORIGINAL CONDITION BY THE CONTRACTOR. THE COST FOR THIS WORK SHALL BE INCIDENTAL TO THE CONTRACT.

RESTORATION GRASS AREAS DISTURBED DURING CONSTRUCTION SHALL BE RESTORED WITH 150 mm TOPSOIL AND SEED OR SOD AS SPECIFIED. PAYMENT SHALL BE ACCORDING TO THE ITEMS USED. USE BLANKET IN SEEDING AREAS LOCATED WITHIN FLOW LINES, ALONG THE SHORELINE OF THE CREEK, AND ON SLOPES 1:3 OR GREATER.

ACCESS THE CONTRACTOR SHALL BE AWARE OF POTENTIAL LIMITED ACCESS TO PORTIONS OF THE PROJECT. TEMPORARY DRAINAGE CROSSINGS APPROVED BY THE ENGINEER MAY BE INSTALLED BY THE CONTRACTOR AT HIS/HER EXPENSE TO GAIN ACCESS FOR CONSTRUCTION. THE CONTRACTOR MAY ALSO APPROACH ADJACENT OWNERS FOR THE PURPOSE OF OBTAINING ADDITIONAL ACCESS. SUCH NEGOTIATIONS, HOWEVER, ARE STRICTLY BETWEEN PROPERTY OWNERS AND THE CONTRACTOR. ANY ADDITIONAL COSTS INCURRED BY THE CONTRACTOR AS A RESULT SHALL BE AT HIS/HER EXPENSE.

SEDIMENTATION AND EROSION CONTROL NOTES

- SOIL DISTURBANCE SHALL BE CONDUCTED IN SUCH A MANNER AS TO MINIMIZE EROSION. SOIL STABILIZATION MEASURES SHALL CONSIDER THE TIME OF YEAR, SITE CONDITIONS AND THE USE OF TEMPORARY OR PERMANENT MEASURES.
- SOIL EROSION AND SEDIMENT CONTROL FEATURES SHALL BE CONSTRUCTED PRIOR TO THE COMMENCEMENT OF UPLAND DISTURBANCE.
- TEMPORARY SOIL STABILIZATION SHALL BE APPLIED TO DISTURBED AREAS WITHIN 14 CALENDAR DAYS OF THE END OF ACTIVE HYDROLOGIC DISTURBANCE. PERMANENT STABILIZATION SHALL BE DONE WITHIN 14 DAYS AFTER COMPLETION OF FINAL GRADING OF THE SOIL.
- ALL STORM SEWER FACILITIES THAT ARE OR WILL BE FUNCTIONING DURING CONSTRUCTION SHALL BE PROTECTED, FILTERED, OR OTHERWISE TREATED TO REMOVE SEDIMENT.
- ALL TEMPORARY EROSION AND SEDIMENT CONTROL MEASURES SHALL BE REMOVED WITHIN 30 DAYS AFTER FINAL SITE STABILIZATION IS ACHIEVED OR AFTER THE TEMPORARY MEASURES ARE NO LONGER NEEDED. TRAPPED SEDIMENT AND OTHER DISTURBED SOIL AREAS SHALL BE PERMANENTLY STABILIZED.
- ALL TEMPORARY AND PERMANENT EROSION CONTROL MEASURES MUST BE MAINTAINED AND REPAIRED AS NEEDED. THE GENERAL CONTRACTOR WILL BE RESPONSIBLE FOR INSPECTION AND REPAIR DURING CONSTRUCTION.
- THE EROSION CONTROL MEASURES INDICATED ON THE PLANS ARE THE MINIMUM REQUIREMENTS. ADDITIONAL MEASURES MAY BE REQUIRED, AS DIRECTED BY THE ENGINEER OR GOVERNING AGENCY.
- THE CONTRACTOR SHALL INSTALL ALL EROSION CONTROL PRIOR TO THE START OF ANY EARTHWORK.
- IF A STOCKPILE IS TO REMAIN IN PLACE FOR MORE THAN THREE DAYS, EROSION CONTROL MEASURES SHALL BE PROVIDED.
- EROSION CONTROL MEASURES SHALL COMPLY WITH THE MINIMUM REQUIREMENTS OF THE DUPAGE COUNTY STORMWATER AND FLOODPLAIN ORDINANCE SPECIFICATIONS AT ALL TIMES.

HIGHWAY STANDARDS

CONTRACT NO. 83714

- 000001-4 STANDARD SYMBOLS, ABBREVIATIONS AND PATTERNS
- 280001-02 TEMPORARY EROSION CONTROL SYSTEMS
- 424001-04 CURB RAMPS FOR SIDEWALK
- 542301 PRECAST REINFORCED CONCRETE FLARED END SECTION
- 602001 CATCH BASIN, TYPE A
- 602301-01 INLET TYPE A
- 602401-01 MANHOLE, TYPE A
- 604001-02 FRAME AND LIDS TYPE 1
- 604091-01 FRAME AND GRATE, TYPE 24
- 606001-02 CONCRETE CURB TYPE B & COMBINATION CONCRETE CURB AND GUTTER
- 606201 TYPE B GUTTER (INLET, OUTLET & ENTRANCE)
- 701601-04 URBAN LANE CLOSURE MULTILANE 1W OR 2W WITH NONTRAVERSABLE MEDIAN
- 701606-04 URBAN LANE CLOSURE MULTILANE 2W WITH MOUNTABLE MEDIAN
- 701701-04 URBAN LANE CLOSURE MULTILANE INTERSECTION
- 702001-06 TRAFFIC CONTROL DEVICES
- 720001 SIGN PANEL MOUNTING DETAILS
- 720006 SIGN PANEL ERECTION DETAILS
- 720011 METAL POSTS FOR SIGNS, MARKERS & DELINEATORS
- 729001 APPLICATION OF TYPE A AND B METAL POSTS (FOR SIGNS & MARKERS)

KANE-DUPAGE SOIL AND WATER DISTRICT NOTES

UNLESS OTHERWISE INDICATED, ALL VEGETATIVE AND STRUCTURAL EROSION AND SEDIMENT CONTROL PRACTICES WILL BE CONSTRUCTED TO MINIMUM STANDARDS AND SPECIFICATIONS IN THE ILLINOIS URBAN MANUAL REVISED FEBRUARY 2002.

THE KANE-DUPAGE SOIL AND WATER CONSERVATION DISTRICT (KDSWCD) MUST BE NOTIFIED ONE WEEK PRIOR TO THE PRE-CONSTRUCTION CONFERENCE, ONE WEEK PRIOR TO THE COMMENCEMENT OF LAND DISTURBING ACTIVITIES, AND ONE WEEK PRIOR TO THE FINAL INSPECTION.

A COPY OF THE APPROVED EROSION AND SEDIMENT CONTROL PLAN SHALL BE MAINTAINED ON THE SITE AT ALL TIMES.

PRIOR TO COMMENCING LAND-DISTURBING ACTIVITIES IN AREAS OTHER THAN INDICATED ON THESE PLANS (INCLUDING BUT NOT LIMITED TO, ADDITIONAL PHASES OF DEVELOPMENT AND OFF-SITE BORROW OR WASTE AREAS) A SUPPLEMENTARY EROSION CONTROL PLAN SHALL BE SUBMITTED TO THE OWNER FOR REVIEW BY THE KDSWCD.

THE CONTRACTOR IS RESPONSIBLE FOR INSTALLATION OF ANY ADDITIONAL EROSION CONTROL MEASURES NECESSARY TO PREVENT EROSION AND SEDIMENTATION AS DETERMINED BY THE KDSWCD.

DURING DEWATERING OPERATIONS, WATER WILL BE PUMPED INTO SEDIMENT BASINS OR SILT TRAPS. DEWATERING DIRECTLY INTO FIELD TILES OR STORMWATER STRUCTURES IS PROHIBITED.

REVISIONS		
NO.	NAME	DATE

URS	1701 GOLF ROAD, SUITE 1000 TEL: (847) 228-0707 ROLLING MEADOWS, IL 60008 FAX: (847) 228-1115
	VILLAGE OF OAK BROOK
SALT CREEK GREENWAY TRAIL	
GENERAL CONSTRUCTION NOTES	
AND HIGHWAY STANDARDS	
DATE: 7/20/05	DRAWN BY: MJA&VP
DESIGNED BY: MIA	CHECKED BY: DDL

SECTION	COUNTY	TOTAL SHEETS	SHEET NO.
02-00034-00-BT	DUPAGE	108	3
STA. TO STA.			
IDOT PROJECT NO. M-8003(216)			
SALT CREEK GREENWAY TRAIL			
CONTRACT NO. 83714			

CODE NO	PAY ITEM	TOTAL		ELMHURST PARK DISTRICT		VILLAGE OF VILLA PARK		VILLAGE OF OAK BROOK		DUPAGE FOREST PRESERVE DISTRICT	
		UNIT	TOTAL QUANTITY	BIKE PATH	STRUCTURES	BIKE PATH	STRUCTURES	BIKE PATH	STRUCTURES	BIKE PATH	STRUCTURES
				Y047	X032-2A	Y047	N/A	Y047	X032-2A	Y047	N/A
M2010110	TREE REMOVAL (6 TO 15 UNITS DIAMETER)	UNIT	992	575				315		102	
M2010210	TREE REMOVAL (OVER 15 UNITS DIAMETER)	UNIT	283	133				70		80	
20101200	TREE ROOT PRUNING	EACH	25					21		4	
M2020010	EARTH EXCAVATION	CU M	6,448	5923		3		512		10	
M2021200	REMOVAL AND DISPOSAL OF UNSUITABLE MATERIAL	CU M	10,263	7801		259		1837		366	
M2040800	FURNISHED EXCAVATION	CU M	396			92		192		112	
M2070420	POROUS GRANULAR EMBANKMENT, SUBGRADE	CU M	852	529		41		230		52	
M2080150	TRENCH BACKFILL	CU M	89	21				62		6	
M2101000	GEOTECHNICAL FABRIC FOR GROUND STABILIZATION	SQ M	13,909	8,738		645		3702		824	
M2113150	TOPSOIL FURNISH AND PLACE, 150 MM	SQ M	27,232	20,205		676		5528		823	
M2130010	EXPLORATION TRENCH, SPECIAL	METER	20								
* M2500115	SEEDING, CLASS 1B	HA	1.1	0.4		0.1		0.5		0.1	
* M2500312	SEEDING, CLASS 4A	HA	0.9	0.7				0.1		0.1	
* M2500400	NITROGEN FERTILIZER NUTRIENT	KG	190	110		10		60		10	
* M2500500	PHOSPHORUS FERTILIZER NUTRIENT	KG	190	110		10		60		10	
* M2500600	POTASSIUM FERTILIZER NUTRIENT	KG	190	110		10		60		10	
* M2510105	MULCH, METHOD 1	HA	2.0	1.1		0.1		0.6		0.2	
* M2510630	EROSION CONTROL BLANKET	SQ M	2,200	1000		100		1000		100	
* M2520110	SODDING, SALT TOLERANT	SQ M	400	100		100		100		100	
M2520200	SUPPLEMENTAL WATERING	UNIT	8	4		1		2		1	
28000300	TEMPORARY DITCH CHECKS	EACH	25	16				5		4	
M2800400	PERIMETER EROSION BARRIER	METER	5,046	4054		410		134		448	
M2810103	STONE RIPRAP, CLASS A2	SQ M	10	10							
M2820200	FILTER FABRIC	SQ M	10	10							
M3511100	AGGREGATE BASE COURSE, TYPE B 100MM	SQ M	150	150							
M3511150	AGGREGATE BASE COURSE, TYPE B 150 MM	SQ M	11,734	7,369		537		3141		687	
M4060100	BITUMINOUS MATERIALS (PRIME COAT)	LITER	10,515	6501		537		2790		687	
M4205200	PROTECTIVE COAT	SQ M	1,424	1,014		3		407			
M4240150	PORTLAND CEMENT CONCRETE SIDEWALK 150MM	SQ M	1,385	1006		6		373			
M4402000	PAVEMENT REMOVAL	SQ M	389	347				42			
M4402020	CURB REMOVAL	METER	16					16			
M4402045	COMBINATION CONCRETE CURB AND GUTTER	METER	44	36		4		4			
	REMOVAL AND REPLACEMENT										
M4812100	AGGREGATE SHOULDERS, TYPE B 100MM	SQ M	93	93							
50101500	REMOVAL OF EXISTING SUPERSTRUCTURES	EACH	1		1.0						
M5010240	CONCRETE REMOVAL	CU M	11.4		10.0			1.4			
M5010465	SLOPE WALL REMOVAL	SQ M	265		85				180		
M5010522	PIPE CULVERT REMOVAL	METER	6					6			
M5020100	STRUCTURE EXCAVATION	CU M	398.9		205.9				193.0		
M5030350	CONCRETE STRUCTURES	CU M	346.9		185.7				161.2		

* SPECIALTY ITEM

REVISIONS		
NO.	NAME	DATE

URS 1701 GOLF ROAD, SUITE 1000 TEL (847) 228-0707
ROLLING MEADOWS, IL 60008 FAX (847) 228-1115

VILLAGE OF OAK BROOK
SALT CREEK GREENWAY TRAIL

SUMMARY OF QUANTITIES

DATE: 5/10/06 DRAWN BY: MIA&VP
DESIGNED BY: MIA CHECKED BY: DDL

SECTION	COUNTY	TOTAL SHEETS	SHEET NO.
02-00034-00-BT	DUPAGE	108	5
STA. TO STA.			
IDOT PROJECT NO. M-8003(216)			
SALT CREEK GREENWAY TRAIL			
CONTRACT NO. 83714			

CODE NO	PAY ITEM	TOTAL		ELMHURST PARK DISTRICT (1)		VILLAGE OF VILLA PARK (2)		VILLAGE OF OAK BROOK (3)		DUPAGE FOREST PRESERVE DISTRICT (4)	
		UNIT	TOTAL QUANTITY	BIKE PATH	STRUCTURES	BIKE PATH	STRUCTURES	BIKE PATH	STRUCTURES	BIKE PATH	STRUCTURES
				Y047	X032-2A	Y047	N/A	Y047	X032-2A	Y047	N/A
* M7800205	PAINT PAVEMENT MARKING - LINE 100MM	METER	3,775	2,348		179		1019		229	
* M7800240	PAINT PAVEMENT MARKING - LINE 600MM	METER	9					9			
△ Z0076600	TRAINEES	HOUR	1,000	1,000							
* A2005016	TREE, GYMNOCLADUS DIOICUS (KENTUCKY COFFEETREE), 2" CALIPER, BALLED AND BURLAPPED	EACH	2	1				1			
* A2006716	TREE, QUERCUS MACROCARPA (BUR OAK), 2" CALIPER, BALLED AND BURLAPPED	EACH	3	2				1			
* D2002288	EVERGREEN, PICEA PUNGENS GLAUCA (COLORADO BLUE SPRUCE), 8' HEIGHT, BALLED AND BURLAPPED	EACH	3					3			
* D2002788	EVERGREEN, PINUS NIGRA (AUSTRIAN PINE), 8' HEIGHT, BALLED AND BURLAPPED	EACH	3					3			
* K1004595	PRUNING FOR SAFETY AND EQUIPMENT CLEARANCE	L SUM	1	0.50				0.25		0.25	
* MX032828	COVER CROP	HA	0.9	0.9							
* MX032950	PERMANENT STEEL SHEET PILING	SQ M	1,560		860				700		
* MX406012	BITUMINOUS CONCRETE SURFACE COURSE, SUPERPAVE, MIX "C", N50	M TON	1,327	820		68		352		87	
* X0444100	BENCHES	EACH	12	6		2		2		2	
* XX002906	TIP DOWN GATE	EACH	6	4		1		1			
* MX032529	SEGMENTAL CONCRETE BLOCK WALL	SQ M	146	97				49			
* MX030570	PEDESTRIAN BRIDGE SUPERSTRUCTURE	SQ M	606		433				173		
* MX030568	LIMESTONE TRAIL SCREENINGS, 50 MM	SQ M	35	35							
* XX006417	LANDSCAPE WALL MODIFICATION	EACH	2					2			
* MX030567	RUSTIC RAIL FENCE	METER	102	58		19		25			
* MX030565	ALUMINUM SIGN POST, SPECIAL	METER	291.1	162.5		36.8		70.8		21.0	
* XX001683	INFORMATION KIOSK	EACH	6	3		1		1		1	
* XX006082	INFORMATION KIOSK GRAPHIC PANEL	EACH	18	9		3		3		3	
* MX033567	WETLAND SEEDING	HA	0.9	0.9							
* MX033568	PLANT CONTROL, ALIEN OR AGGRESSIVE	LITER	4	4							
* M4248000	DETECTABLE WARNINGS	SQ M	17.2	9.0		1.8		6.4			

△ = Y080
* SPECIALTY ITEM

REVISIONS		
NO.	NAME	DATE

URS 1701 GOLF ROAD, SUITE 1000 TEL (847) 228-0707
ROLLING MEADOWS, IL 60008 FAX (847) 228-1115

VILLAGE OF OAK BROOK
SALT CREEK GREENWAY TRAIL

SUMMARY OF QUANTITIES

DATE: 7/20/05 DRAWN BY: MIA&VP
DESIGNED BY: MIA CHECKED BY: DDL

SECTION	COUNTY	TOTAL SHEETS	SHEET NO.
02-00034-00-BT	DUPAGE	108	6
STA. TO STA.			
IDOT PROJECT NO. M-8003(216)			
SALT CREEK GREENWAY TRAIL			

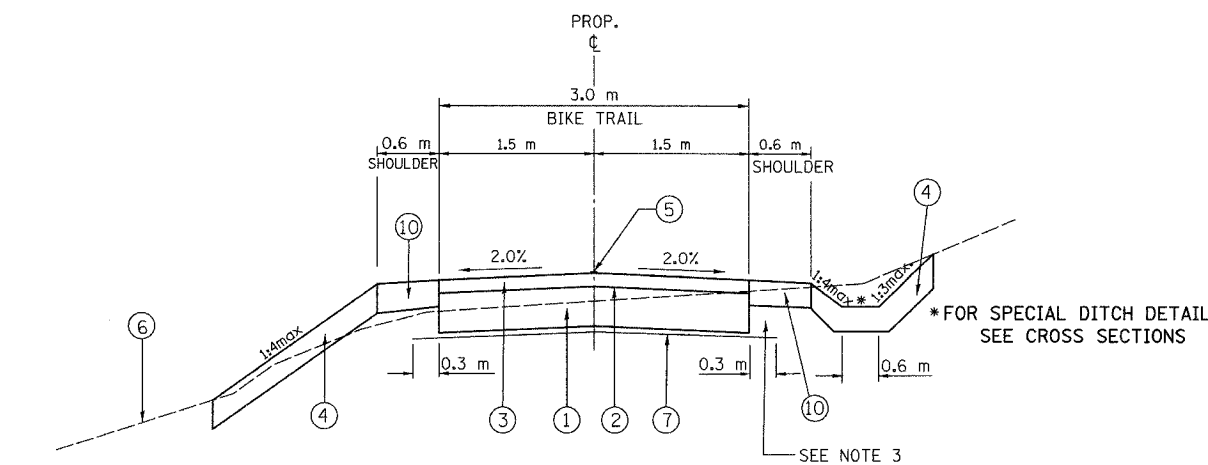

CONSTRUCT DOWNSIDE SWALE WHERE SHOWN ON PLANS

PROPOSED TYPICAL SECTION

- STA. 17+992.517 TO STA. 18+106.226
- STA. 18+164 TO STA. 18+675
- STA. 18+830.998 TO STA. 19+010
- STA. 21+263 TO STA. 22+357
- STA. 22+591 TO STA. 23+002
- STA. 24+350 TO STA. 24+563.36
- STA. 29+220 TO STA. 29+311.891

- STA. 18+139 TO STA. 18+164 - PROPOSED BRIDGE
- STA. 18+774 TO STA. 18+830.998 - PROPOSED BRIDGE
- STA. 22+603.5 TO STA. 22+642 - PROPOSED BRIDGE
- STA. 23+485.08 TO STA. 23+530.08 - PROPOSED BRIDGE

- OMMISSIONS**
- STA. 19+010 TO STA. 21+263 (ON-STREET & EXIST. TRAIL)
 - STA. 22+357 TO STA. 22+591 (EXIST. TRAIL)
 - STA. 23+002 TO STA. 23+200 (EXIST. TRAIL)
 - STA. 24+563.36 TO STA. 29+220 (EXIST. TRAIL & ON-STREET)

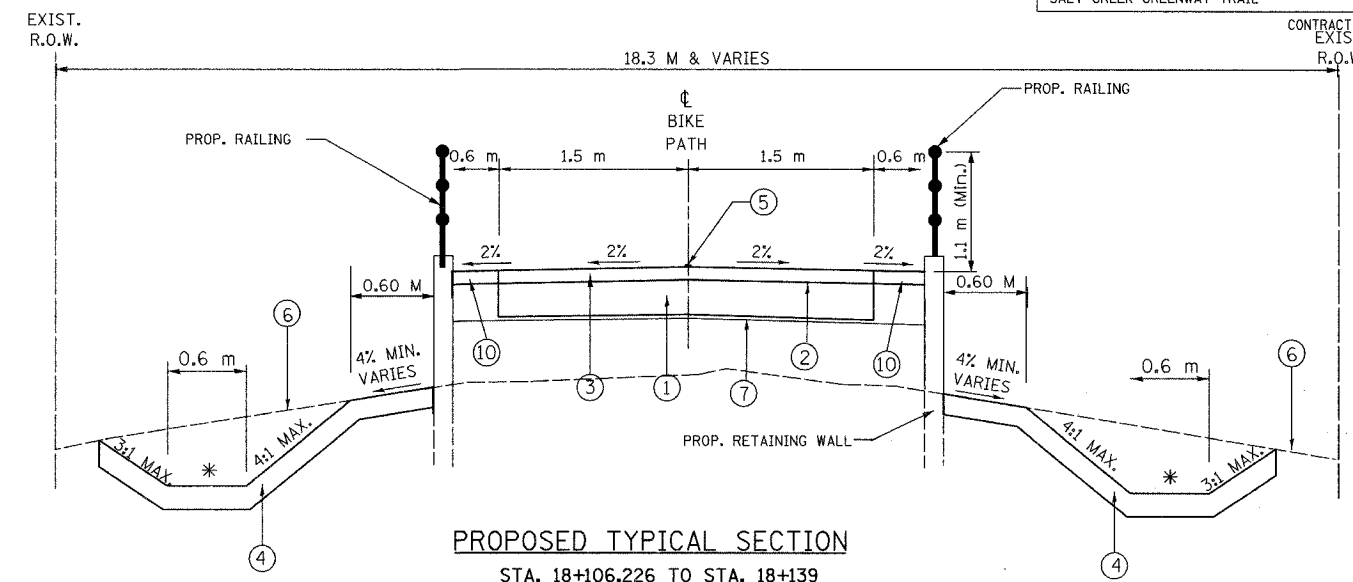

PROPOSED TYPICAL SECTION

STA. 18+106.226 TO STA. 18+139

* FOR SPECIAL DITCH DETAILS SEE CROSS SECTIONS

LEGEND:

- ① AGGREGATE BASE COURSE, TYPE B, 150 mm
- ② BITUMINOUS PRIME COAT
- ③ BITUMINOUS CONCRETE SURFACE COURSE, SUPERPAVE MIX "C", N50, 50 mm
- ④ 150 mm TOP SOIL AND SEEDING CLASS 4A
- ⑤ PAINT PAVEMENT MARKING, 100 mm YELLOW
- ⑥ EXISTING GROUND
- ⑦ GEOTECHNICAL FABRIC FOR GROUND STABILIZATION
- ⑩ 150 mm TOP SOIL AND SEEDING, CLASS 1 B
- ⑮ 100 mm AGGREGATE SHOULDER, TYPE B
- ⑱ P.C.E. SUBGRADE 300 mm
- ⑳ AGGREGATE BASE COURSE, TYPE B, 100 mm

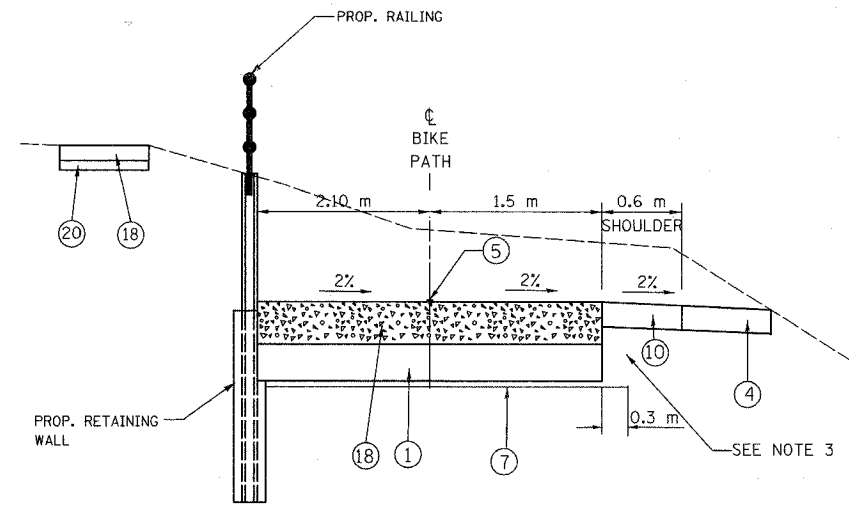

PROPOSED TYPICAL SECTION

STA. 18+675 TO STA. 18+696
STA. 18+727 TO STA. 18+774

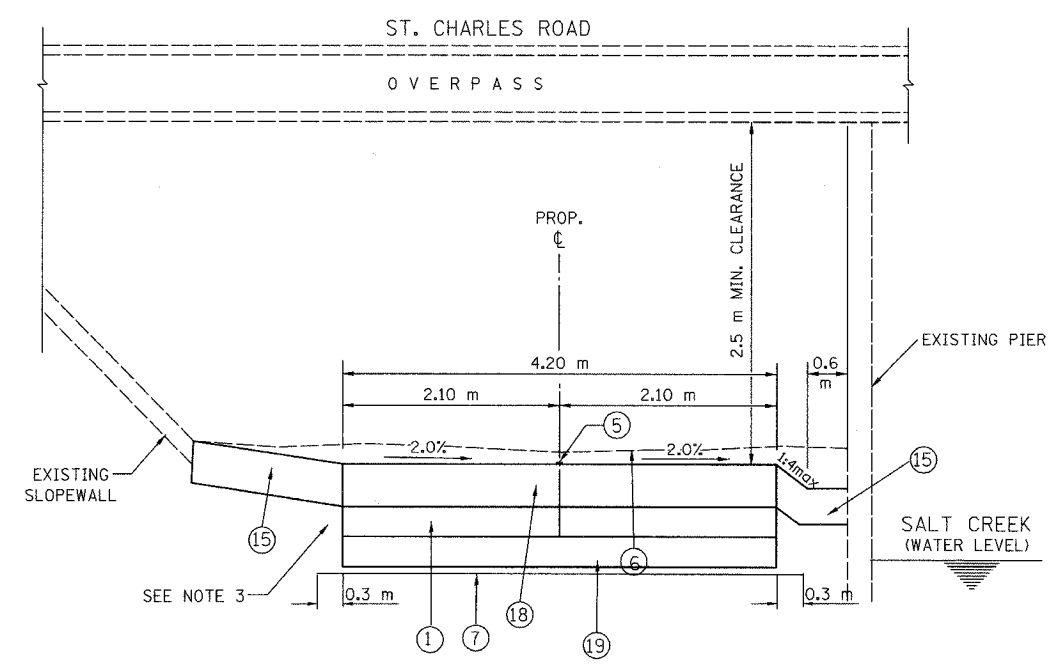

PROPOSED TYPICAL SECTION

STA. 18+696 TO STA. 18+727

NOTE 1:

AT LOCATIONS OF UNSUITABLE MATERIAL, AS DETERMINED BY THE ENGINEER, THE SUBGRADE TREATMENT WILL CONSIST OF EXCAVATION OF UNSUITABLE MATERIAL TO A DEPTH 300 mm BELOW AGGREGATE BASE COURSE AND PLACEMENT OF 300 mm OF POROUS GRANULAR EMBANKMENT SUBGRADE AND A GEOTECHNICAL FABRIC FOR GROUND STABILIZATION.

NOTE 2:

THE CONTRACTOR SHALL CONSTRUCT THE PATH SO THAT THE CROSS SLOPE IS IN THE DIRECTION OF THE GROUND SLOPE WHERE SHEET FLOW ACROSS THE PATH WILL OCCUR. WHERE SHEET FLOW ACROSS THE PATH IS NOT A CONCERN DUE TO THE PRESENCE OF A SWALE ON THE UPSTREAM SIDE, THE CONTRACTOR SHALL SLOPE THE PATH OUT FROM THE CENTERLINE.

NOTE 3:

ADDITIONAL FILL MATERIAL TO BE PLACED ABOVE FABRIC IN CUT SECTIONS SHALL NOT BE MEASURED FOR PAYMENT. MATERIAL SHALL BE SUITABLE EMBANKMENT MATERIAL.

NOTE 4:

AT ALL INTERSECTIONS BIKE PATH AND STREETS/DRIVEWAYS DEPRESS THE CURB (IF APPLICABLE) AND KEEP EXISTING PAVEMENT ELEVATIONS.

ITEM	AC TYPE	VOIDS	RAP %	USAGE
BITUMINOUS CONCRETE SURFACE COURSE, SUPERPAVE, MIX. C, N50	PG 64-22	4% @ 50 GYR	15%	BIKE PATH SURFACE

DESIGNER USED UNIT WEIGHT 112 LBS/SQ YD/IN (2.39 KG/SM/MM) FOR CALCULATION PURPOSES

REVISIONS		
NO.	NAME	DATE

URS 1701 GOLF ROAD, SUITE 1000 TEL (847) 228-0707
ROLLING MEADOWS, IL 60008 FAX (847) 228-1115

VILLAGE OF OAK BROOK
SALT CREEK GREENWAY TRAIL
TYPICAL SECTIONS

DATE: 7/20/05 DRAWN BY: MIA&VP
DESIGNED BY: MIA CHECKED BY: DDL

SECTION	COUNTY	TOTAL SHEETS	SHEET NO.
02-00034-00-BT	DUPAGE	108	7
STA. TO STA.			
IDOT PROJECT NO. M-8003(216)			
SALT CREEK GREENWAY TRAIL			

CONTRACT NO. 83714

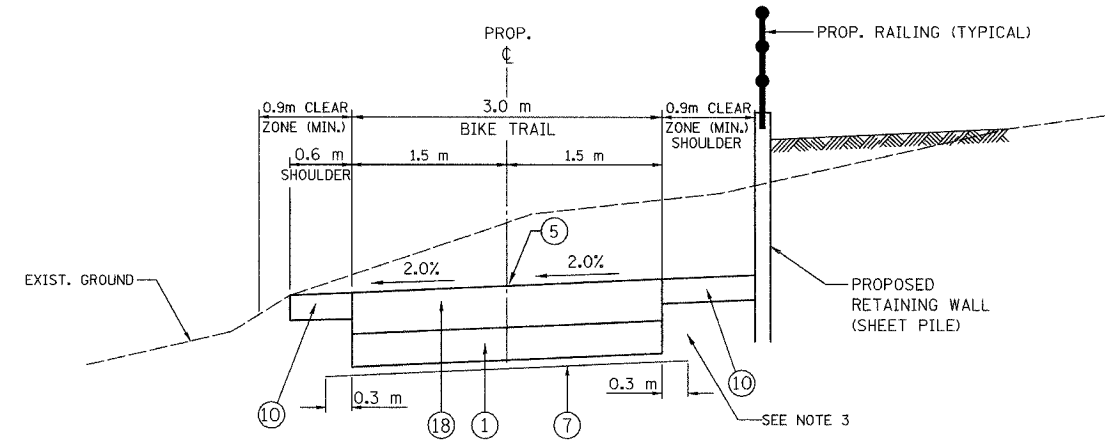

PROPOSED TYPICAL SECTION
STA. 23+200 TO STA. 23+290

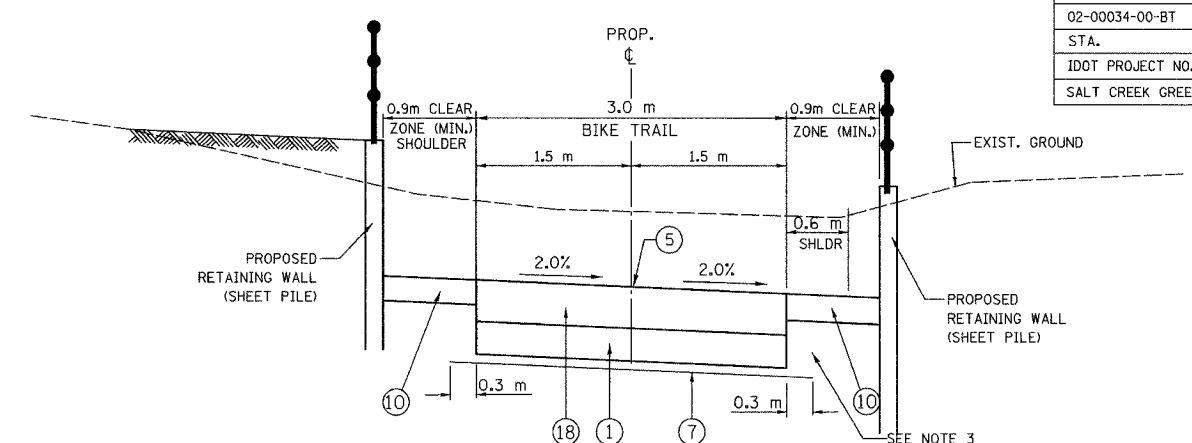

PROPOSED TYPICAL SECTION
STA. 23+393 TO STA. 23+428.4

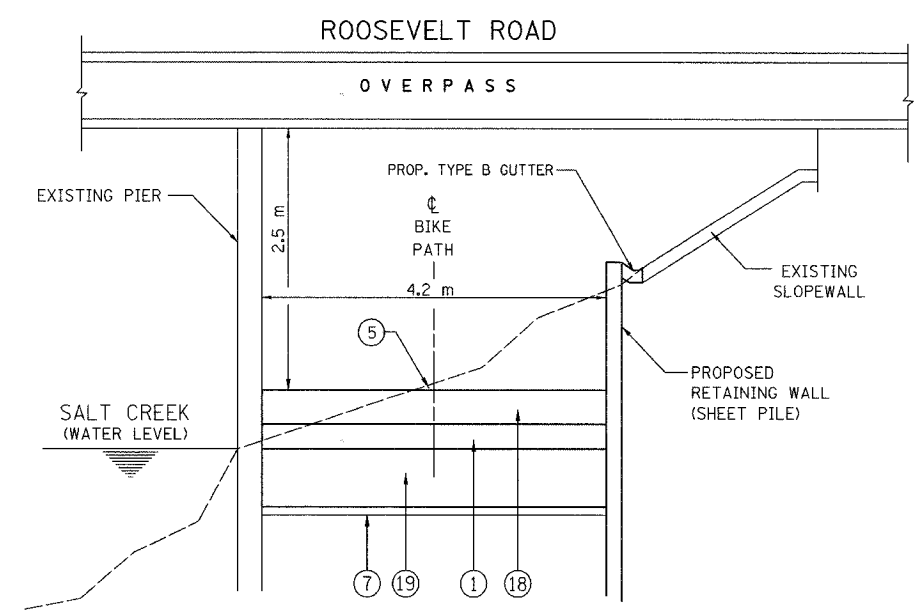

PROPOSED TYPICAL SECTION
STA. 23+290 TO STA. 23+393

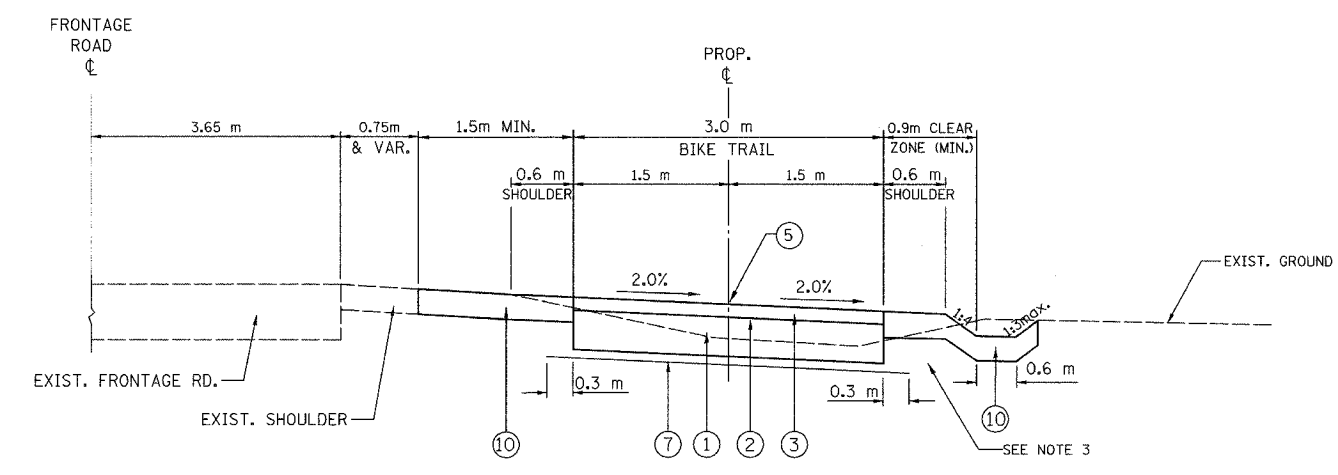

PROPOSED TYPICAL SECTION
STA. 23+428.4 TO STA. 24+350

LEGEND:

- ① AGGREGATE BASE COURSE, TYPE B, 150 mm
- ② BITUMINOUS PRIME COAT
- ③ BITUMINOUS CONCRETE SURFACE COURSE, SUPERPAVE MIX "C", N50, 50 mm
- ④ 150 mm TOP SOIL AND SEEDING CLASS 4A
- ⑤ PAINT PAVEMENT MARKING, 100 mm YELLOW
- ⑥ EXISTING GROUND
- ⑦ GEOTECHNICAL FABRIC FOR GROUND STABILIZATION
- ⑩ 150 mm TOP SOIL AND SEEDING, CLASS 1 B
- ⑮ 100 mm AGGREGATE SHOULDER, TYPE B
- ⑱ P.C.C. SIDEWALK 150 mm
- ⑲ P.G.E. SUBGRADE 300 mm

ITEM	AC TYPE	VOIDS	RAP %	USAGE
BITUMINOUS CONCRETE SURFACE COURSE, SUPERPAVE, MIX. C, N50	PG 64-22	4% @ 50 GYR	15%	BIKE PATH SURFACE

DESIGNER USED UNIT WEIGHT 112 LBS/SQ YD/IN (2.39 KG/SM/MM) FOR CALCULATION PURPOSES

REVISIONS		
NO.	NAME	DATE

URS 1701 GOLF ROAD, SUITE 1000 TEL (847) 228-0707
ROLLING MEADOWS, IL 60008 FAX (847) 228-1115

VILLAGE OF OAK BROOK
SALT CREEK GREENWAY TRAIL
TYPICAL SECTIONS

DATE: 7/20/05 DRAWN BY: MIA&VP
DESIGNED BY: MIA CHECKED BY: DDL

SECTION	COUNTY	TOTAL SHEETS	SHEET NO.
02-00034-00-BT	DUPAGE	108	9
STA. TO STA.			
IDOT PROJECT NO. M-8003(216)			
SALT CREEK GREENWAY TRAIL			
CONTRACT NO. 83714			

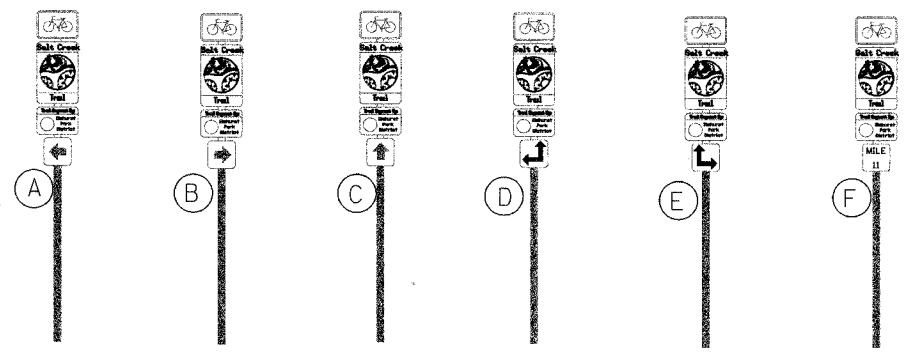
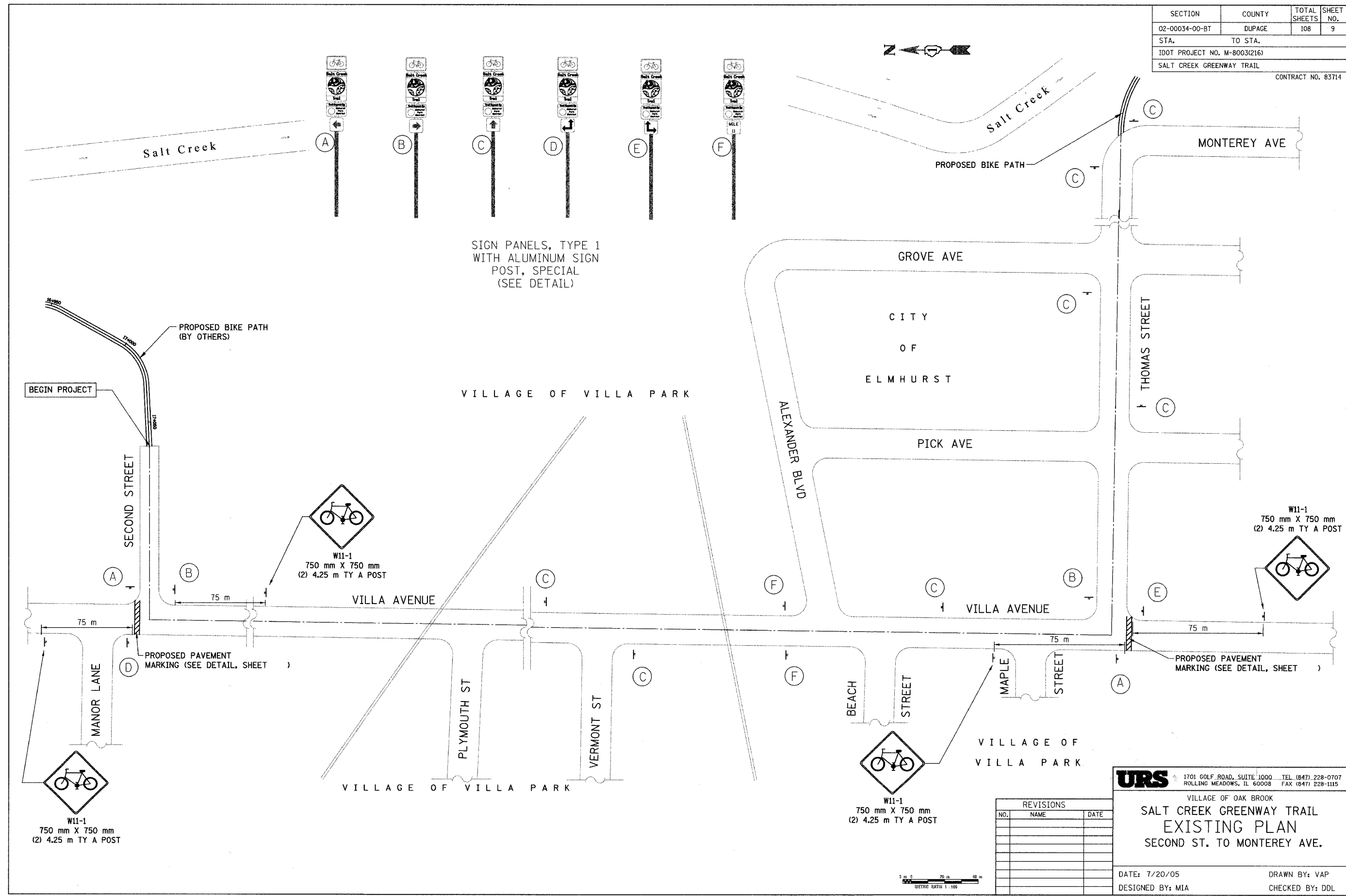

SIGN PANELS, TYPE 1
WITH ALUMINUM SIGN
POST, SPECIAL
(SEE DETAIL)

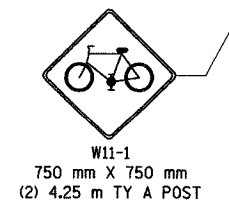
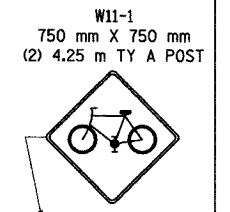
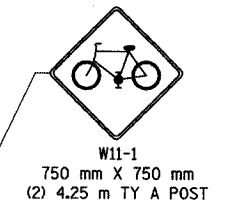
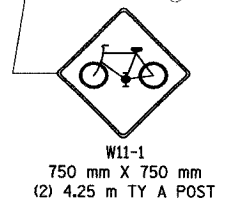
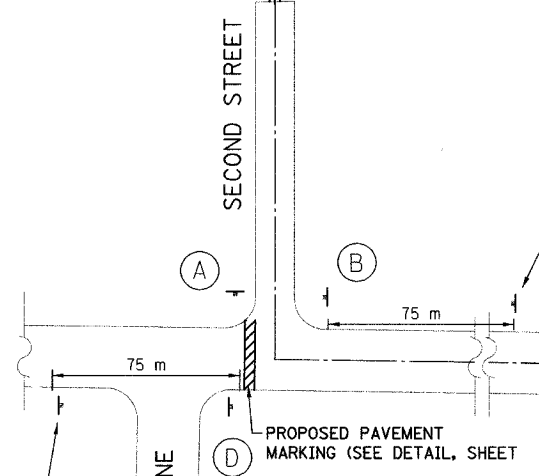
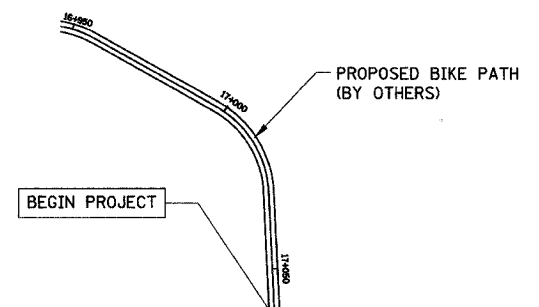

REVISIONS		
NO.	NAME	DATE

URS 1701 GOLF ROAD, SUITE 1000 TEL (847) 228-0707
ROLLING MEADOWS, IL 60008 FAX (847) 228-1115

VILLAGE OF OAK BROOK
**SALT CREEK GREENWAY TRAIL
EXISTING PLAN
SECOND ST. TO MONTEREY AVE.**

DATE: 7/20/05 DRAWN BY: VAP
DESIGNED BY: MIA CHECKED BY: DDL

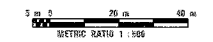

SECTION	COUNTY	TOTAL SHEETS	SHEET NO.
02-00034-00-BT	DUPAGE	108	10
STA. TO STA.			
IDOT PROJECT NO. M-8003(216)			
SALT CREEK GREENWAY TRAIL			
CONTRACT NO. 83714			

PROP. CURVE CL1-3
 PI STA = 18+065.682
 N = 44,976.374
 E = 7,140.673
 $\Delta = 17^\circ 06' 20''$ (LT)
 R = 30,000 m
 T = 4.512 m
 L = 8.956 m
 E = 0.337 m

PROPOSED BICYCLE TRAIL
 AGGREGATE BASE COURSE, TYPE B, 150 mm
 BIT. CONC. SURF. COURSE, SUPERPAVE, MIX
 C N50, 50 mm
 PAINT PVT. MKG. - LINE 100 mm (SOLID
 YELLOW Φ)

STOP
 R1-1
 450mmX450mm
 3.05 m TY A POST
 1.8 SM DETECTABLE WARNING
 6 SM PCC SIDEWALK, 150 MM
 BEGIN CONSTRUCTION
 STA. 17+992.517
 (ELMHURST PARK DISTRICT NORTH SECTION)

LEGEND

- SWALE TIP
- ↔ DITCH SUMMIT
- ◆ DITCH CHECK
- PROPOSED CULVERT
- - - EXISTING CULVERT
- ⊙ EXISTING MANHOLE
- - - EXISTING FENCE
- ▶ FLARED END SECTION
- ⊕ INLET AND PIPE PROTECTION
- ⊗ TREE REMOVAL
- PERIMETER EROSION BARRIER

PROP. CURVE CL1-1
 PI STA = 18+013.139
 N = 45,001.065
 E = 7,095.193
 $\Delta = 9^\circ 29' 36''$ (RT)
 R = 40,000 m
 T = 3.321 m
 L = 6.628 m
 E = 0.138 m

PROP. CURVE CL1-2
 PI STA = 18+038.954
 N = 44,993.341
 E = 7,119.841
 $\Delta = 21^\circ 45' 46''$ (RT)
 R = 30,000 m
 T = 5.767 m
 L = 11.395 m
 E = 0.549 m

PROP. CURVE CL1-4
 PI STA = 18+086.028
 N = 44,968.708
 E = 7,159.592
 $\Delta = 7^\circ 39' 12''$ (RT)
 R = 30,000 m
 T = 2.007 m
 L = 4.007 m
 E = 0.067 m

PROP. CURVE CL1-5
 PI STA = 18+098.155
 N = 44,962.695
 E = 7,170.130
 $\Delta = 31^\circ 39' 35''$ (RT)
 R = 30,000 m
 T = 8.506 m
 L = 16.577 m
 E = 1.183 m

PROP. CURVE CL1-6
 PI STA = 18+126.791
 N = 44,937.178
 E = 7,184.060
 $\Delta = 9^\circ 56' 49''$ (RT)
 R = 30,000 m
 T = 2.611 m
 L = 5.208 m
 E = 0.113 m

PROP. CURVE CL1-7
 PI STA = 18+184.696
 N = 44,882.312
 E = 7,202.613
 $\Delta = 17^\circ 51' 26''$ (RT)
 R = 100,000 m
 T = 15.711 m
 L = 31.167 m
 E = 1.227 m

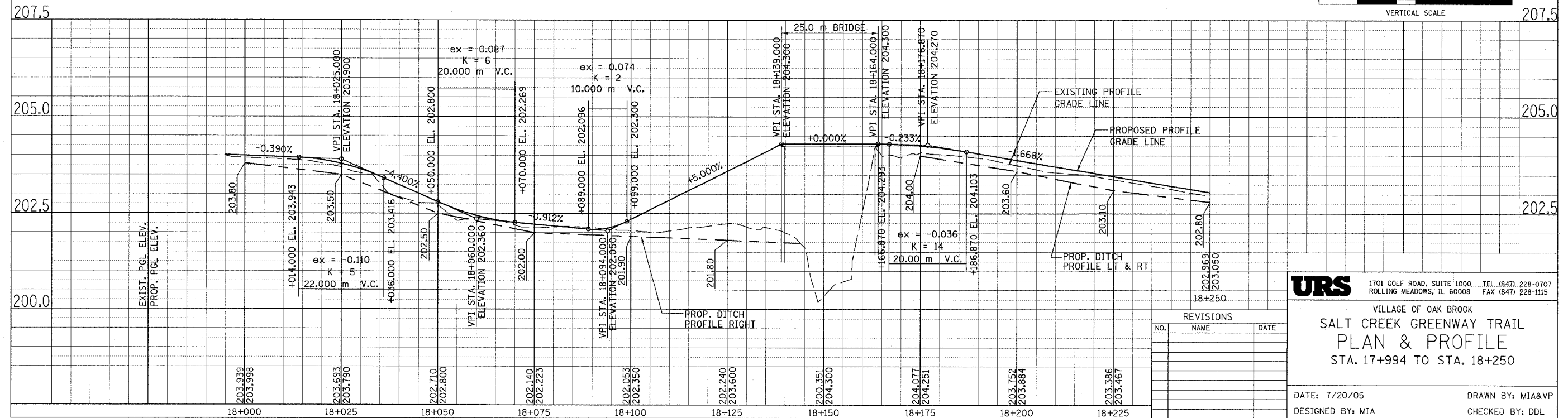
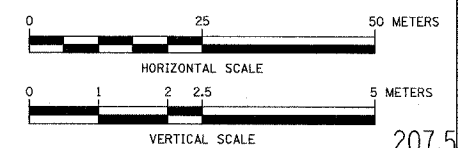

URS 1701 GOLF ROAD, SUITE 1000 TEL (847) 228-0707
 ROLLING MEADOWS, IL 60008 FAX (847) 228-1115

VILLAGE OF OAK BROOK
**SALT CREEK GREENWAY TRAIL
 PLAN & PROFILE**
 STA. 17+994 TO STA. 18+250

DATE: 7/20/05 DRAWN BY: MIA&VP
 DESIGNED BY: MIA CHECKED BY: DDL

REVISIONS		
NO.	NAME	DATE

SECTION	COUNTY	TOTAL SHEETS	SHEET NO.
02-00034-00-BT	DUPAGE	108	12
STA. TO STA.			
IDOT PROJECT NO. M-8003(216)			
SALT CREEK GREENWAY TRAIL			

CONTRACT NO. 83714



SIGN PANELS, TYPE 1 WITH ALUMINUM SIGN POST, SPECIAL (SEE DETAIL)



SIGN PANELS, TYPE 1 WITH ALUMINUM SIGN POST, SPECIAL (SEE DETAIL)

PROP. CURVE CL1-15	PROP. CURVE CL1-16	PROP. CURVE CL1-17	PROP. CURVE CL1-19	PROP. CURVE CL1-21
PI STA = 18+622.481 N = 44,478.553 E = 7,144.556 $\Delta = 26^\circ 42' 21''$ (LT) R = 30,000 m T = 7.121 m L = 13.983 m E = 0.834 m	PI STA = 18+649.455 N = 44,461.742 E = 7,123.132 $\Delta = 46^\circ 26' 47''$ (LT) R = 30,000 m T = 12.872 m L = 24.319 m E = 2.645 m	PI STA = 18+683.960 N = 44,425.973 E = 7,119.730 $\Delta = 18^\circ 57' 42''$ (LT) R = 30,000 m T = 5.010 m L = 9.928 m E = 0.415 m	PI STA = 18+732.836 N = 44,377.524 E = 7,123.907 $\Delta = 46^\circ 52' 42''$ (LT) R = 30,000 m T = 13.007 m L = 24.545 m E = 2.698 m	PI STA = 18+847.089 N = 44,268.495 E = 7,148.476 $\Delta = 61^\circ 35' 14''$ (LT) R = 27,000 m T = 16.091 m L = 29.022 m E = 4.431 m

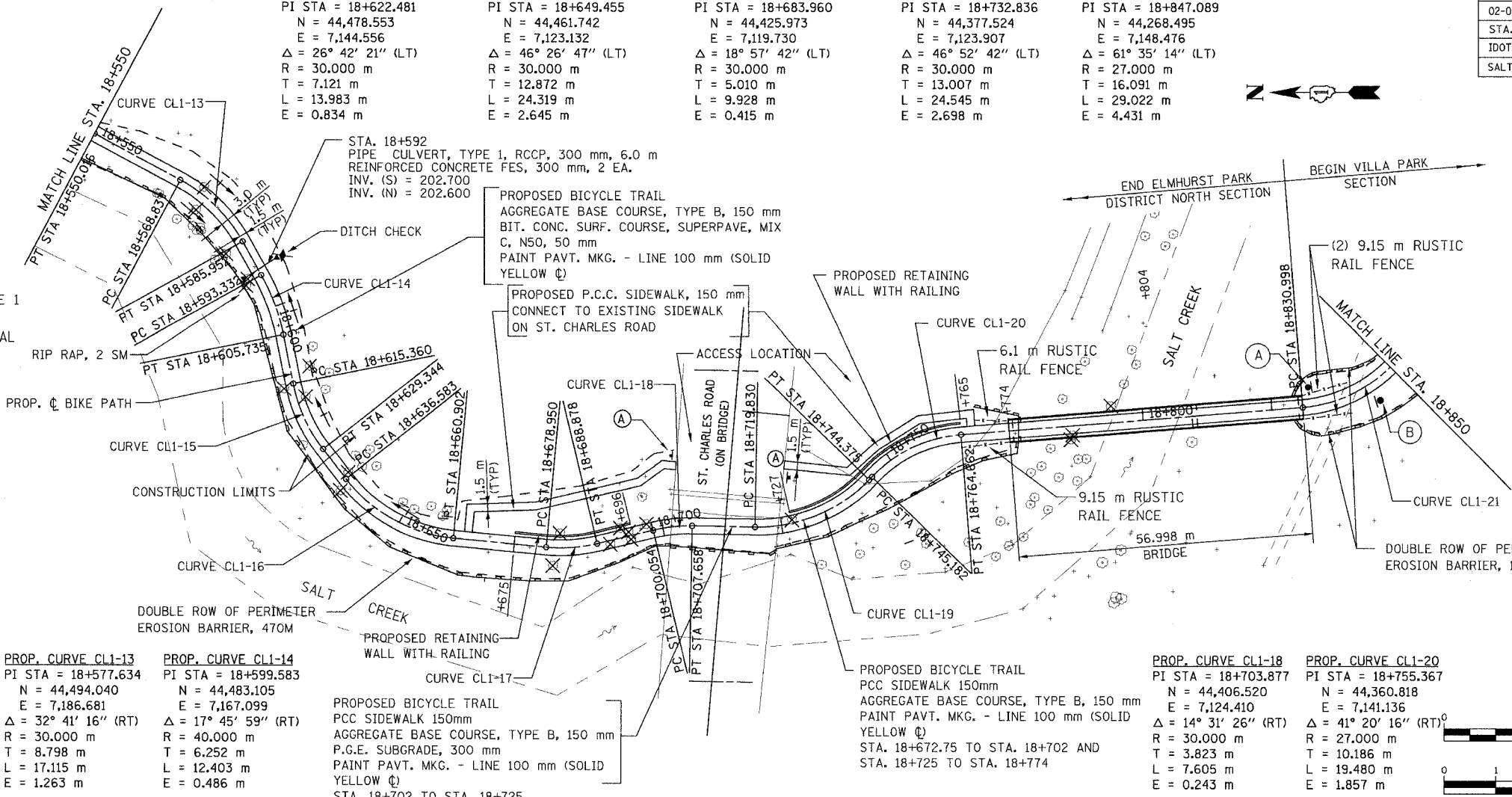
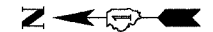

PROP. CURVE CL1-13	PROP. CURVE CL1-14	PROP. CURVE CL1-17	PROP. CURVE CL1-18	PROP. CURVE CL1-20
PI STA = 18+577.634 N = 44,494.040 E = 7,186.681 $\Delta = 32^\circ 41' 16''$ (RT) R = 30,000 m T = 8.798 m L = 17.115 m E = 1.263 m	PI STA = 18+599.583 N = 44,483.105 E = 7,167.099 $\Delta = 17^\circ 45' 59''$ (RT) R = 40,000 m T = 6.252 m L = 12.403 m E = 0.486 m	PI STA = 18+702.000 N = 44,406.520 E = 7,124.410 $\Delta = 14^\circ 31' 26''$ (RT) R = 30,000 m T = 3.823 m L = 7.605 m E = 0.243 m	PI STA = 18+703.877 N = 44,406.520 E = 7,124.410 $\Delta = 14^\circ 31' 26''$ (RT) R = 30,000 m T = 3.823 m L = 7.605 m E = 0.243 m	PI STA = 18+755.367 N = 44,360.818 E = 7,141.136 $\Delta = 41^\circ 20' 16''$ (RT) R = 27,000 m T = 10.186 m L = 19.480 m E = 1.857 m

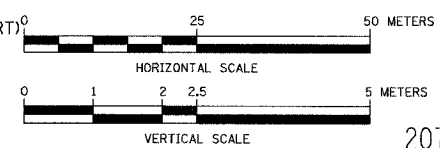

FOR LEGEND SEE SHEET NO. 10

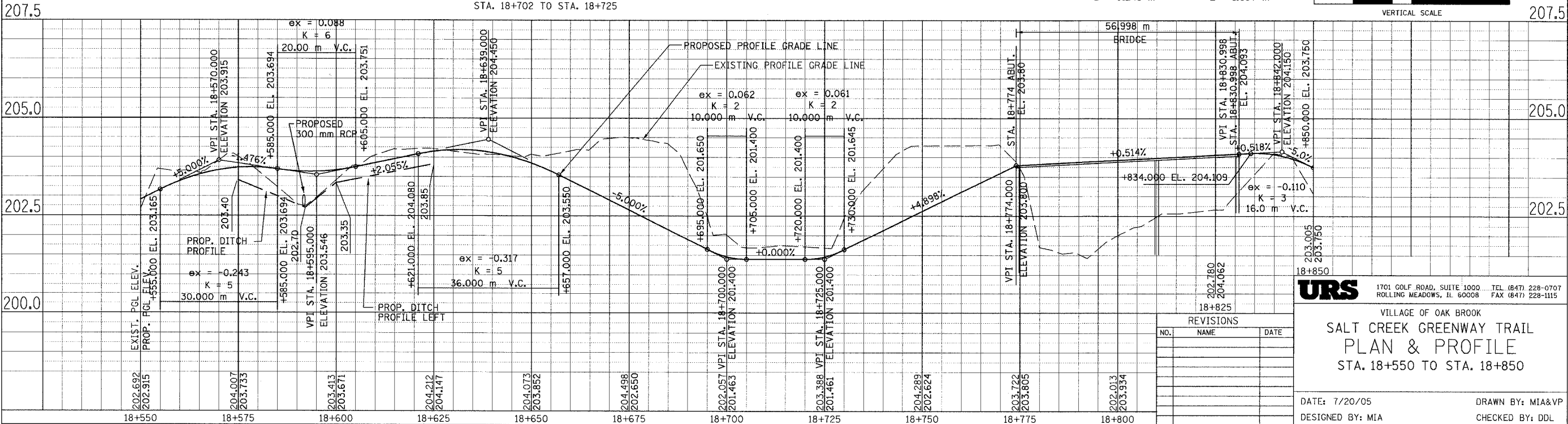

URS 1701 GOLF ROAD, SUITE 1000 TEL (847) 228-0707 ROLLING MEADOWS, IL 60008 FAX (847) 228-1115

VILLAGE OF OAK BROOK
SALT CREEK GREENWAY TRAIL
PLAN & PROFILE
STA. 18+550 TO STA. 18+850

DATE: 7/20/05 DRAWN BY: MIA&VP
DESIGNED BY: MIA CHECKED BY: DDL

REVISIONS		
NO.	NAME	DATE

PROP. CURVE CL1-21
 PI STA = 18+847.089
 N = 44,268.495
 E = 7,148.476
 $\Delta = 61^\circ 35' 14''$ (LT)
 R = 27,000 m
 T = 16.091 m
 L = 29.022 m
 E = 4.431 m

PROPOSED BICYCLE TRAIL
 AGGREGATE BASE COURSE, TYPE B, 150 mm
 BIT. CONC. SURF. COURSE, SUPERPAVE, MIX
 C, N50, 50 mm
 PAINT PAVT. MKG. - LINE 100 mm (SOLID
 YELLOW \square)

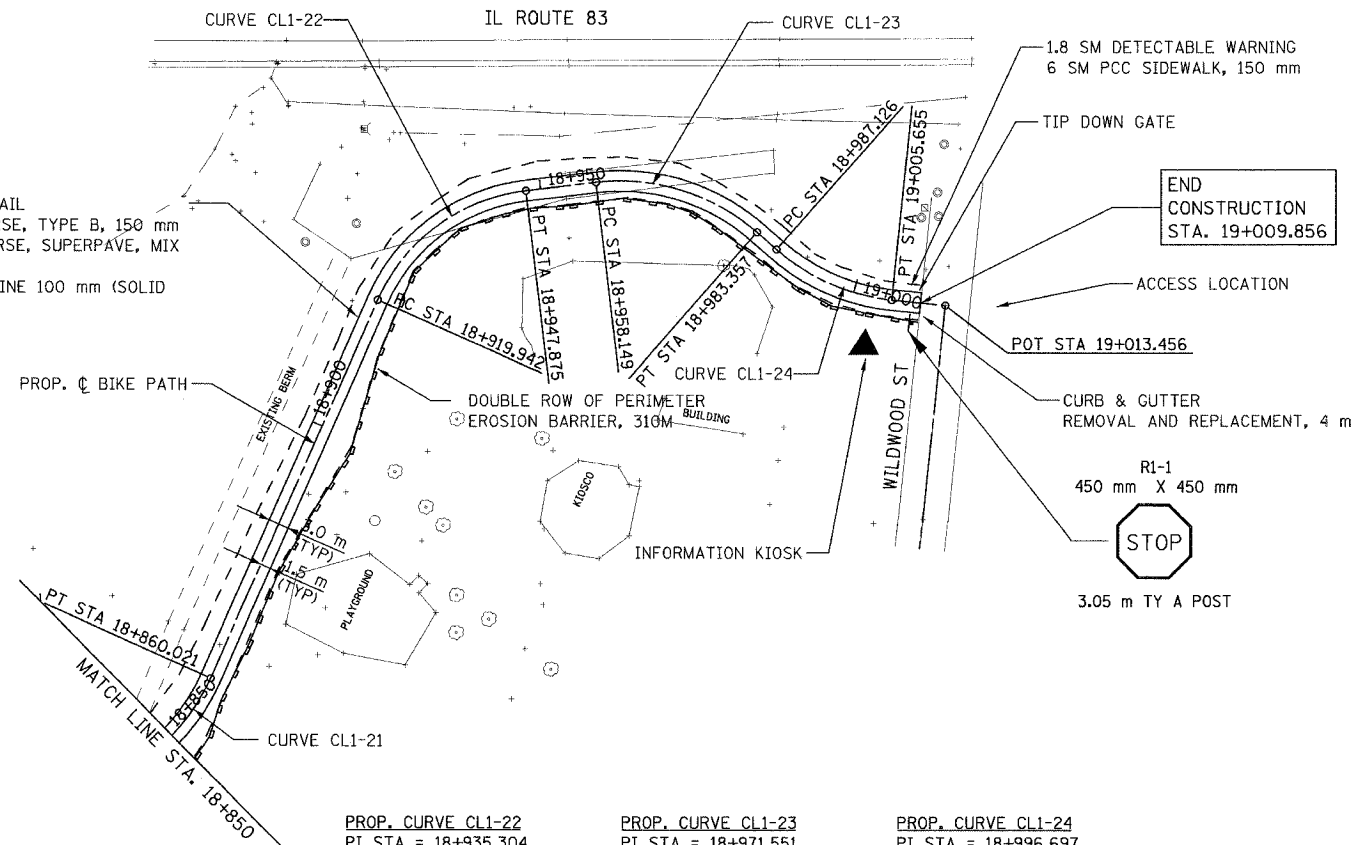

PROP. CURVE CL1-22
 PI STA = 18+935.304
 N = 44,231.524
 E = 7,232.036
 $\Delta = 59^\circ 16' 30''$ (RT)
 R = 27,000 m
 T = 15.362 m
 L = 27.933 m
 E = 4.064 m

PROP. CURVE CL1-23
 PI STA = 18+971.551
 N = 44,192.766
 E = 7,236.697
 $\Delta = 48^\circ 08' 37''$ (RT)
 R = 30,000 m
 T = 13.402 m
 L = 25.208 m
 E = 2.857 m

PROP. CURVE CL1-24
 PI STA = 18+996.697
 N = 44,172.671
 E = 7,219.052
 $\Delta = 35^\circ 23' 12''$ (LT)
 R = 30,000 m
 T = 9.570 m
 L = 18.528 m
 E = 1.490 m

SECTION	COUNTY	TOTAL SHEETS	SHEET NO.
02-00034-00-BT	DUPAGE	108	13
STA.	TO STA.		
IDOT PROJECT NO. M-8003(216)			
SALT CREEK GREENWAY TRAIL			
CONTRACT NO. 83714			



FOR LEGEND SEE SHEET NO. 10

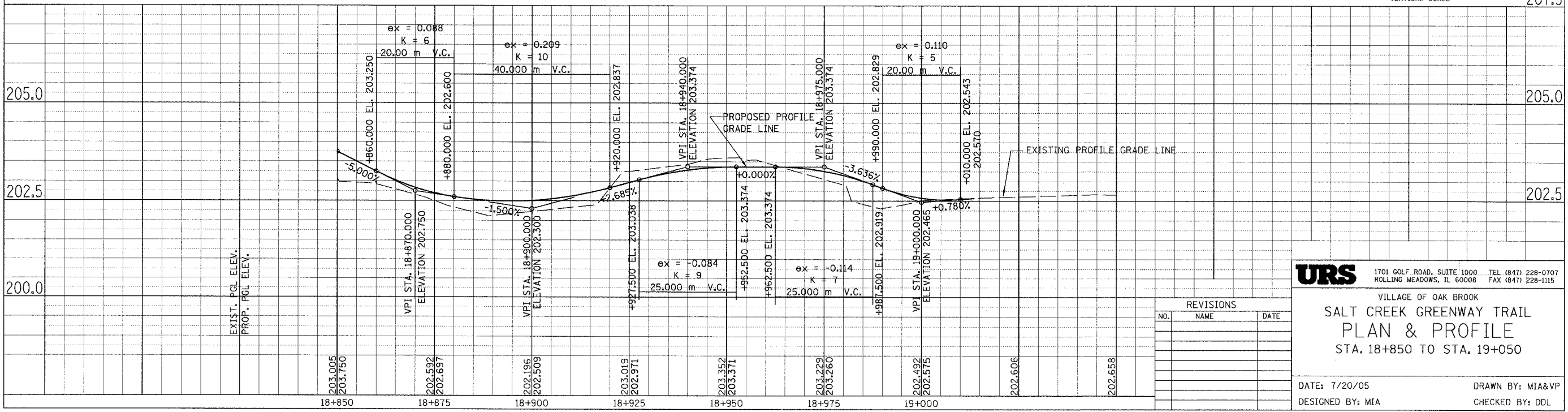
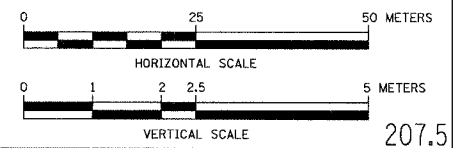

URS 1701 GOLF ROAD, SUITE 1000 TEL (847) 228-0707
 ROLLING MEADOWS, IL 60008 FAX (847) 228-1115

VILLAGE OF OAK BROOK
 SALT CREEK GREENWAY TRAIL
 PLAN & PROFILE
 STA. 18+850 TO STA. 19+050

REVISIONS		
NO.	NAME	DATE

DATE: 7/20/05 DRAWN BY: MIA&VP
 DESIGNED BY: MIA CHECKED BY: DDL

CITY OF ELMHURST

SECTION	COUNTY	TOTAL SHEETS	SHEET NO.
02-00034-00-BT	DUPAGE	108	14
STA. TO STA.			
IDOT PROJECT NO. M-8003(216)			
SALT CREEK GREENWAY TRAIL			
CONTRACT NO. 83714			

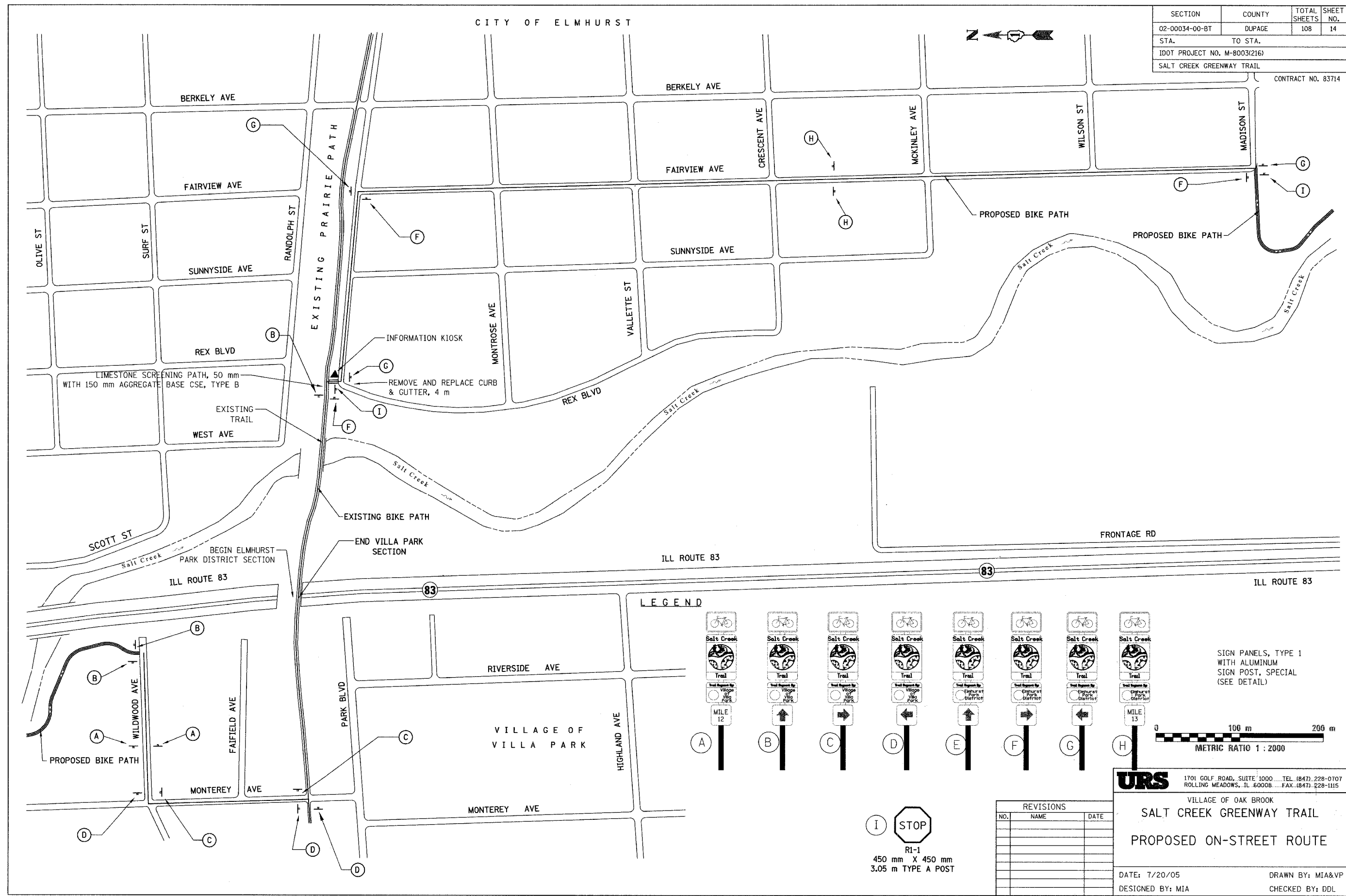

LEGEND

Legend showing sign panels A through H:

- A:** Salt Creek Trail sign with bicycle symbol and 'MILE 12' marker.
- B:** Salt Creek Trail sign with bicycle symbol and 'MILE 13' marker.
- C:** Salt Creek Trail sign with bicycle symbol and directional arrow.
- D:** Salt Creek Trail sign with bicycle symbol and directional arrow.
- E:** Salt Creek Trail sign with bicycle symbol and directional arrow.
- F:** Salt Creek Trail sign with bicycle symbol and directional arrow.
- G:** Salt Creek Trail sign with bicycle symbol and directional arrow.
- H:** Salt Creek Trail sign with bicycle symbol and directional arrow.

I STOP
RI-1
450 mm X 450 mm
3.05 m TYPE A POST

SIGN PANELS, TYPE 1 WITH ALUMINUM SIGN POST, SPECIAL (SEE DETAIL)

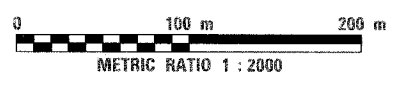

REVISIONS		
NO.	NAME	DATE

URS 1701 GOLF ROAD, SUITE 1000 TEL (847) 228-0707
ROLLING MEADOWS, IL 60008 FAX (847) 228-1115

VILLAGE OF OAK BROOK
SALT CREEK GREENWAY TRAIL
PROPOSED ON-STREET ROUTE

DATE: 7/20/05 DRAWN BY: MIA&VP
DESIGNED BY: MIA CHECKED BY: DDL

SECTION	COUNTY	TOTAL SHEETS	SHEET NO.
02-00034-00-BT	DUPAGE	108	15
STA. TO STA.			
IDOT PROJECT NO. M-8003(216)			
SALT CREEK GREENWAY TRAIL			

CONTRACT NO. 83714

PROP. CURVE CL2-1
 PI STA = 21+401.350
 N = 42,734.785
 E = 7,482.362
 $\Delta = 122^\circ 33' 12''$ (LT)
 R = 30,000 m
 T = 54.743 m
 L = 64.169 m
 E = 32.424 m

PROP. CURVE CL2-2
 PI STA = 21+453.835
 N = 42,648.446
 E = 7,528.306
 $\Delta = 19^\circ 04' 49''$ (RT)
 R = 30,000 m
 T = 5.042 m
 L = 9.990 m
 E = 0.421 m

PROP. CURVE CL2-3
 PI STA = 21+464.285
 N = 42,638.030
 E = 7,529.945
 $\Delta = 13^\circ 56' 23''$ (LT)
 R = 30,000 m
 T = 3.668 m
 L = 7.299 m
 E = 0.223 m

PROP. CURVE CL2-4
 PI STA = 21+489.188
 N = 42,615.053
 E = 7,539.640
 $\Delta = 29^\circ 15' 58''$ (LT)
 R = 30,000 m
 T = 7.833 m
 L = 15.324 m
 E = 1.006 m

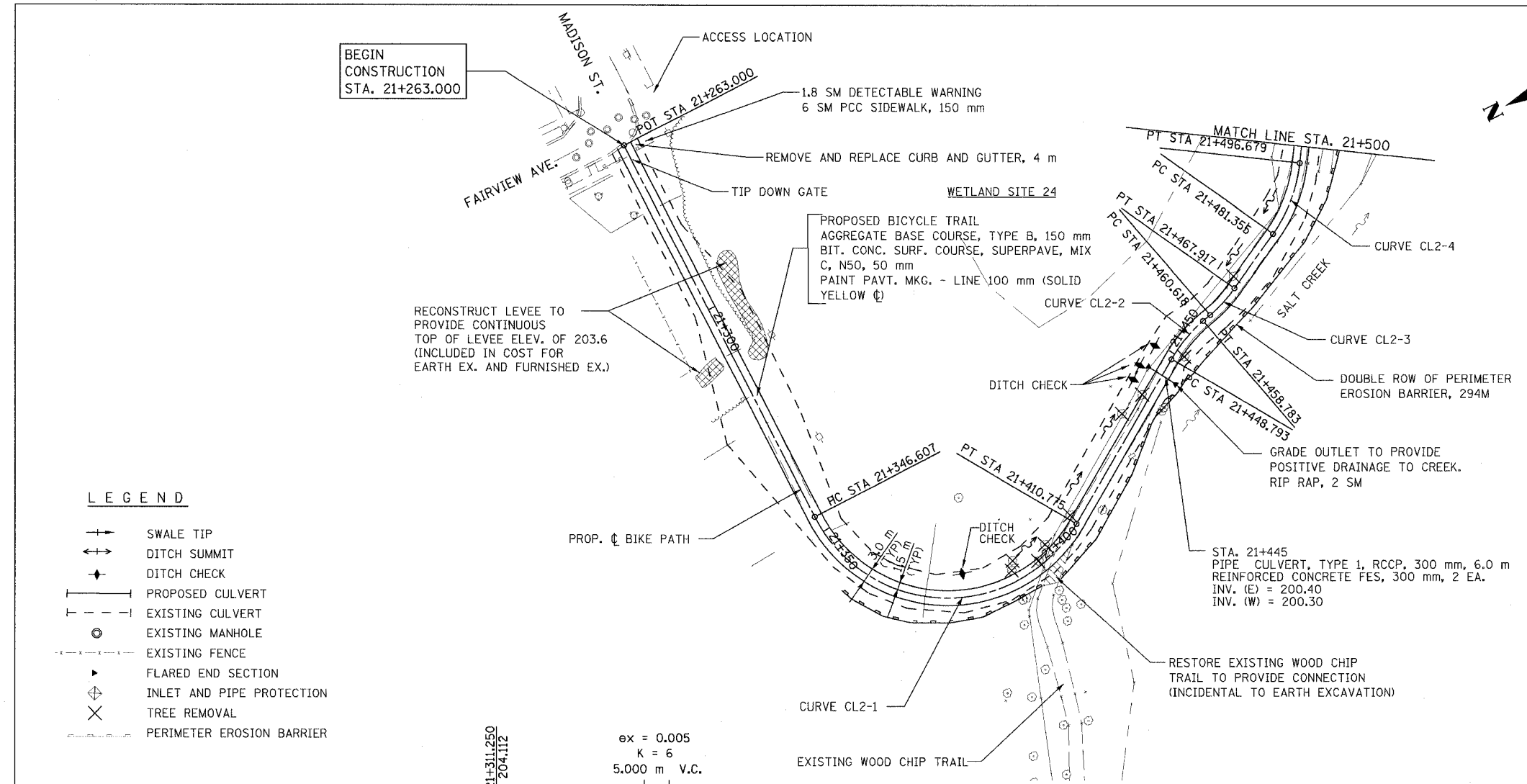

- LEGEND**
- +— SWALE TIP
 - +— DITCH SUMMIT
 - +— DITCH CHECK
 - +— PROPOSED CULVERT
 - +— EXISTING CULVERT
 - +— EXISTING MANHOLE
 - +— EXISTING FENCE
 - +— FLARED END SECTION
 - +— INLET AND PIPE PROTECTION
 - +— TREE REMOVAL
 - +— PERIMETER EROSION BARRIER

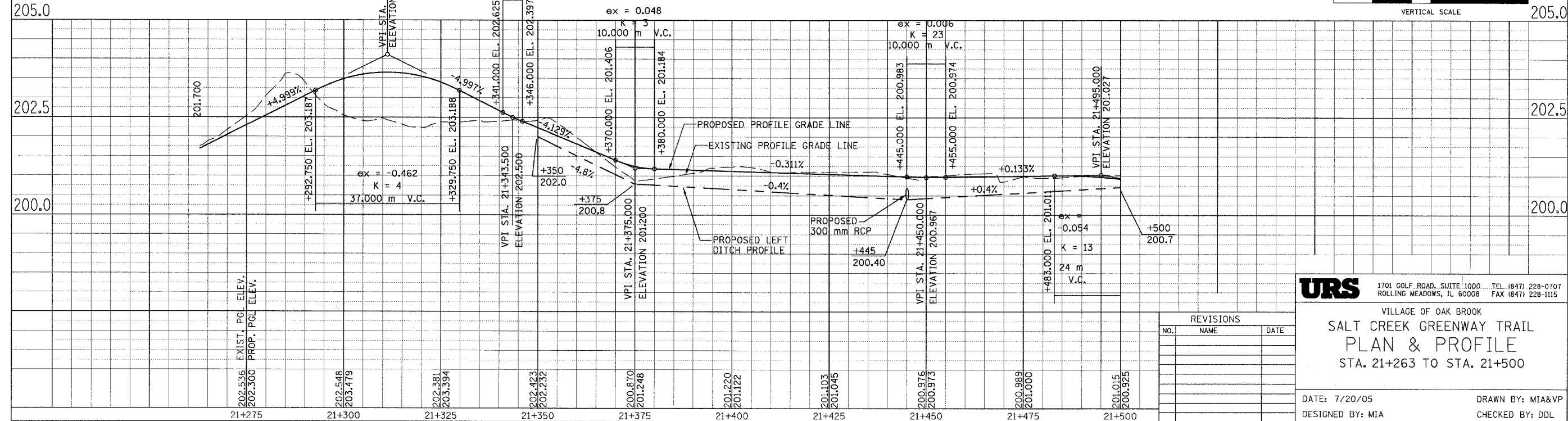
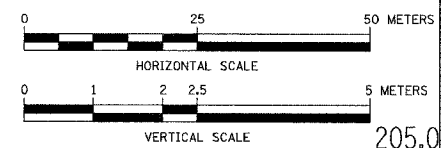

URS 1701 GOLF ROAD, SUITE 1000 ... TEL (847) 228-0707
 ROLLING MEADOWS, IL 60008 FAX (847) 228-1115

VILLAGE OF OAK BROOK
**SALT CREEK GREENWAY TRAIL
 PLAN & PROFILE**
 STA. 21+263 TO STA. 21+500

DATE: 7/20/05 DRAWN BY: MIA&VP
 DESIGNED BY: MIA CHECKED BY: DDL

REVISIONS		
NO.	NAME	DATE

PROP. CURVE CL2-5 PI STA = 21+554.615 N = 42,574.692 E = 7,591.569 $\Delta = 32^\circ 31' 35''$ (RT) R = 30.000 m T = 8.752 m L = 17.031 m E = 1.250 m	PROP. CURVE CL2-6 PI STA = 21+585.279 N = 42,545.363 E = 7,602.023 $\Delta = 68^\circ 35' 21''$ (LT) R = 30.000 m T = 20.460 m L = 35.913 m E = 6.313 m	PROP. CURVE CL2-7 PI STA = 21+664.384 N = 42,542.732 E = 7,686.094 $\Delta = 103^\circ 23' 41''$ (RT) R = 30.000 m T = 37.983 m L = 54.137 m E = 18.402 m	PROP. CURVE CL2-8 PI STA = 21+703.323 N = 42,484.086 E = 7,670.175 $\Delta = 14^\circ 36' 36''$ (LT) R = 50.000 m T = 6.410 m L = 12.750 m E = 0.409 m	PROP. CURVE CL2-9 PI STA = 21+742.308 N = 42,445.034 E = 7,669.781 $\Delta = 7^\circ 31' 06''$ (LT) R = 200.000 m T = 13.141 m L = 26.244 m E = 0.431 m
---	--	--	---	--

SECTION	COUNTY	TOTAL SHEETS	SHEET NO.
02-00034-00-BT	DUPAGE	108	16
STA. TO STA.			
IDOT PROJECT NO. M-8003(216)			
SALT CREEK GREENWAY TRAIL			
CONTRACT NO. 63714			

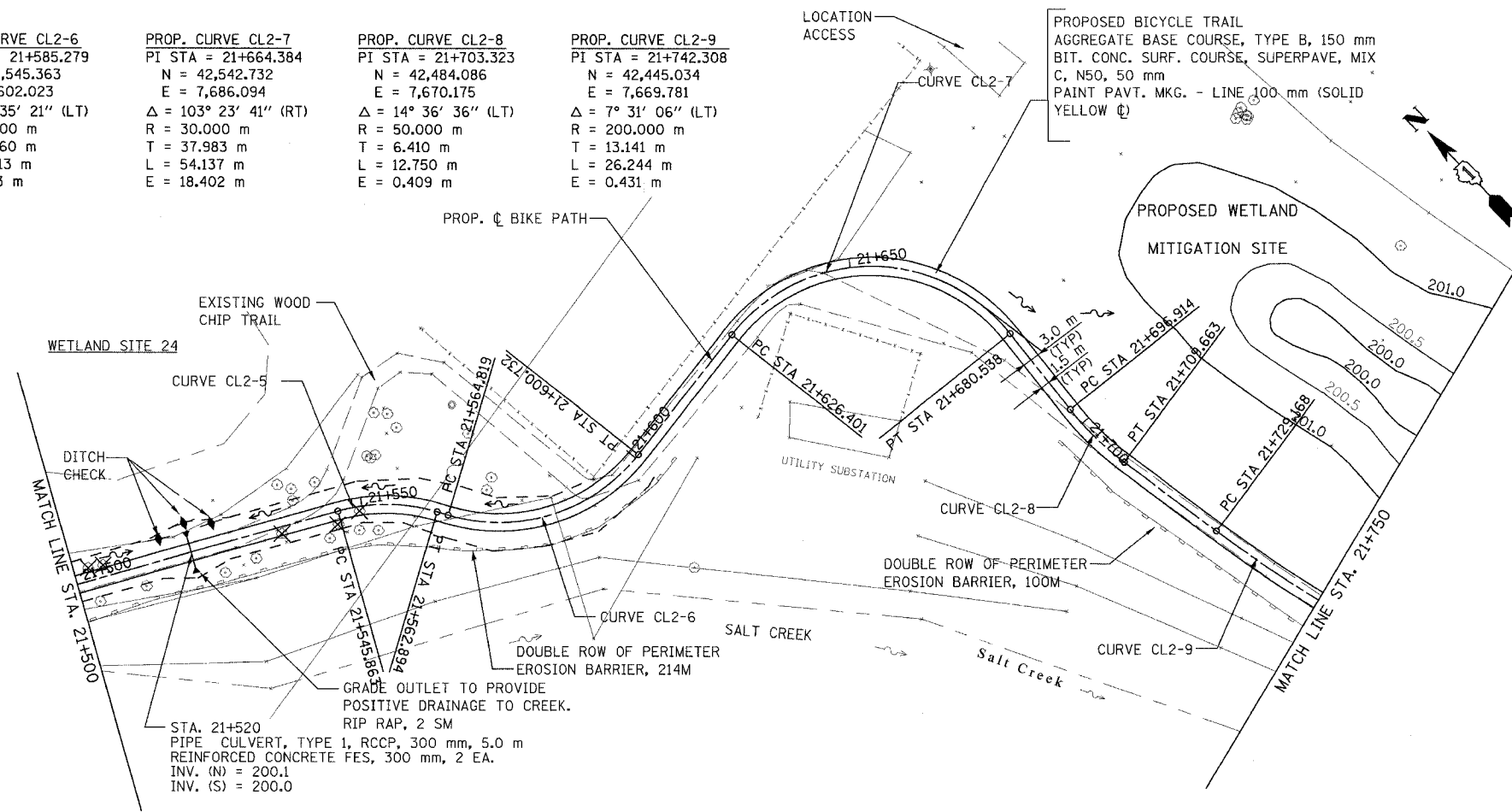

STA. 21+520
PIPE CULVERT, TYPE 1, RCCP, 300 mm, 5.0 m
REINFORCED CONCRETE FES, 300 mm, 2 EA.
INV. (N) = 200.1
INV. (S) = 200.0

FOR LEGEND SEE SHEET NO. 15

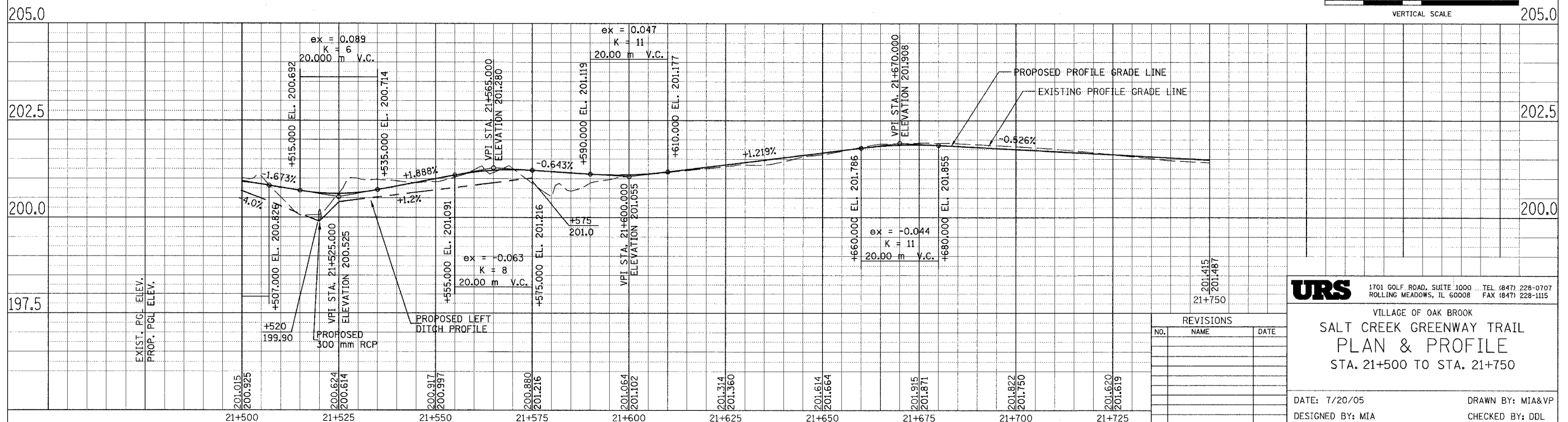
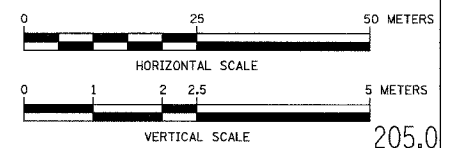

REVISIONS		
NO.	NAME	DATE

URS 1701 GOLF ROAD, SUITE 1000 ... TEL (847) 228-0707
ROLLING MEADOWS, IL 60008 FAX (847) 228-1115

VILLAGE OF OAK BROOK
**SALT CREEK GREENWAY TRAIL
PLAN & PROFILE**
STA. 21+500 TO STA. 21+750

DATE: 7/20/05 DRAWN BY: MIA&VP
DESIGNED BY: MIA CHECKED BY: DDL

SECTION	COUNTY	TOTAL SHEETS	SHEET NO.
02-00034-00-BT	DUPAGE	108	17
STA. TO STA.			
IDOT PROJECT NO. M-8003(216)			
SALT CREEK GREENWAY TRAIL			

CONTRACT NO. 83714

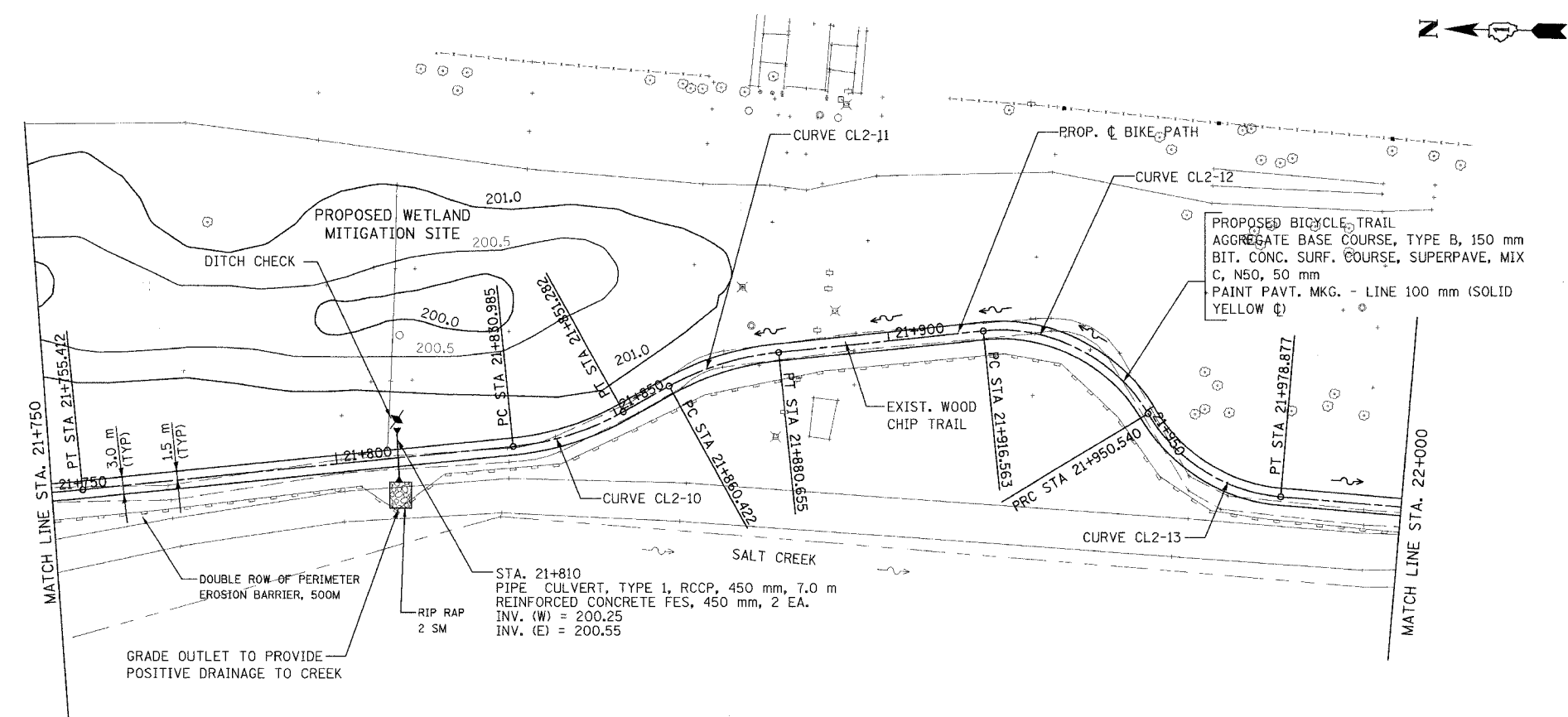

PROP. CURVE CL2-10 PI STA = 21+841.275 N = 42,346.754 E = 7,681.745 $\Delta = 23^\circ 15' 34''$ (LT) R = 50,000 m T = 10.291 m L = 20.298 m E = 1.048 m	PROP. CURVE CL2-11 PI STA = 21+870.679 N = 42,321.097 E = 7,696.679 $\Delta = 23^\circ 11' 05''$ (RT) R = 50,000 m T = 10.257 m L = 20.233 m E = 1.041 m
---	---

PROP. CURVE CL2-12 PI STA = 21+935.635 N = 42,256.348 E = 7,704.647 $\Delta = 64^\circ 53' 29''$ (RT) R = 30,000 m T = 19.072 m L = 33.977 m E = 5.549 m	PROP. CURVE CL2-13 PI STA = 21+965.865 N = 42,238.057 E = 7,675.516 $\Delta = 54^\circ 07' 05''$ (LT) R = 30,000 m T = 15.325 m L = 28.336 m E = 3.687 m
---	---

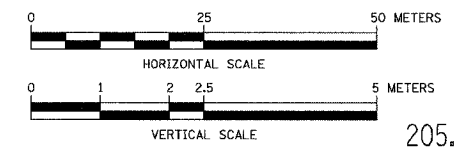

FOR LEGEND SEE SHEET NO. 15

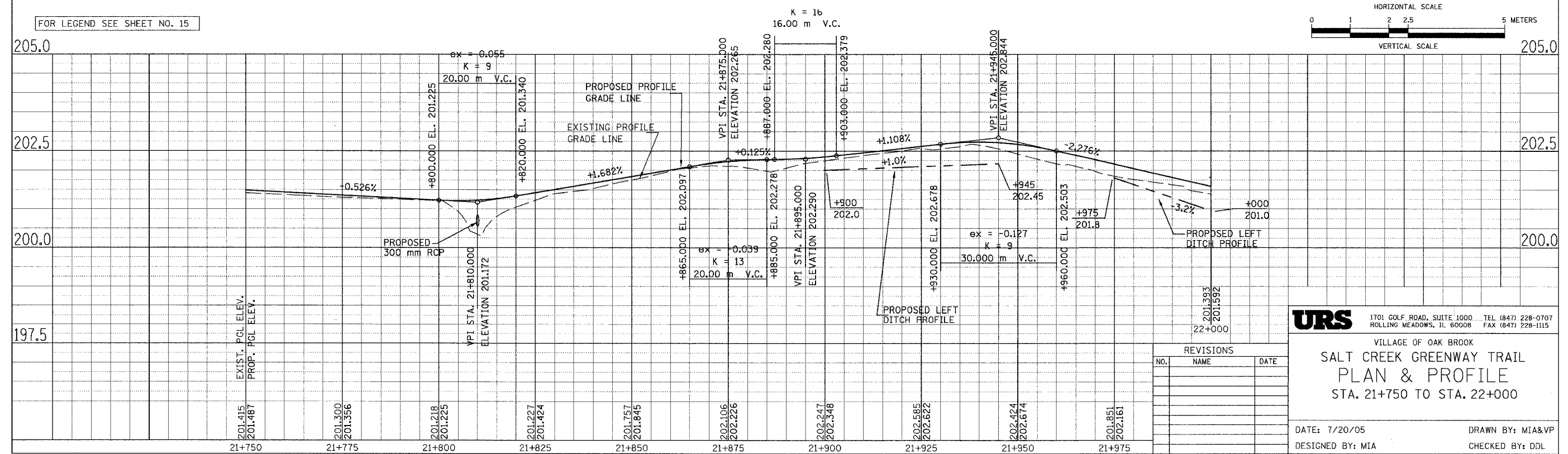

URS 1701 GOLF ROAD, SUITE 1000 TEL (847) 228-0707
ROLLING MEADOWS, IL 60008 FAX (847) 228-1115

VILLAGE OF OAK BROOK
**SALT CREEK GREENWAY TRAIL
PLAN & PROFILE
STA. 21+750 TO STA. 22+000**

DATE: 7/20/05 DRAWN BY: MIA&VP
DESIGNED BY: MIA CHECKED BY: DDL

REVISIONS		
NO.	NAME	DATE

PROP. CURVE CL2-14 PI STA = 22+025.394 N = 42,176.348 E = 7,671.463 $\Delta = 3^\circ 34' 24''$ (LT) R = 100.000 m T = 3.119 m L = 6.237 m E = 0.049 m	PROP. CURVE CL2-15 PI STA = 22+045.721 N = 42,156.019 E = 7,671.398 $\Delta = 5^\circ 51' 12''$ (RT) R = 100.000 m T = 5.112 m L = 10.216 m E = 0.131 m	PROP. CURVE CL2-16 PI STA = 22+093.128 N = 42,108.866 E = 7,666.411 $\Delta = 2^\circ 16' 16''$ (LT) R = 200.000 m T = 3.964 m L = 7.927 m E = 0.039 m	PROP. CURVE CL2-17 PI STA = 22+183.335 N = 42,018.853 E = 7,660.484 $\Delta = 21^\circ 26' 37''$ (LT) R = 100.000 m T = 18.935 m L = 37.426 m E = 1.777 m	PROP. CURVE CL2-18 PI STA = 22+286.462 N = 41,920.173 E = 7,691.933 $\Delta = 39^\circ 15' 01''$ (LT) R = 30.000 m T = 10.697 m L = 20.551 m E = 1.850 m
---	--	---	--	---

SECTION	COUNTY	TOTAL SHEETS	SHEET NO.
02-00034-00-BT	DUPAGE	108	18
STA. TO STA.			
IDOT PROJECT NO. M-8003(216)			
SALT CREEK GREENWAY TRAIL			

CONTRACT NO. 83714

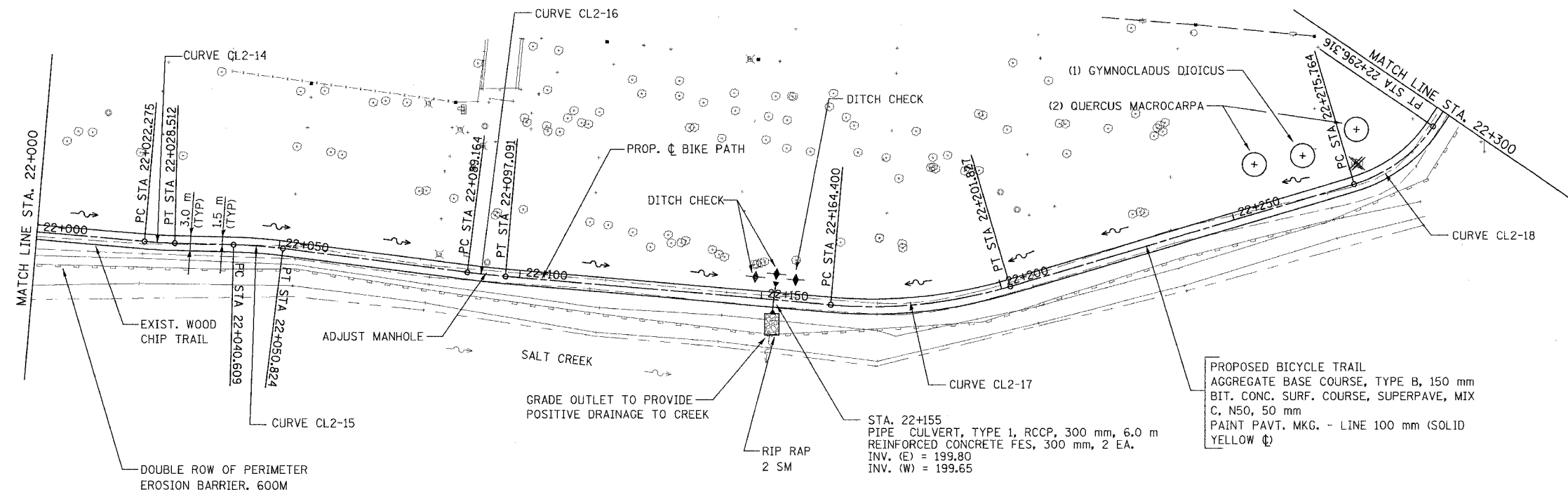
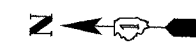

PROPOSED BICYCLE TRAIL
 AGGREGATE BASE COURSE, TYPE B, 150 mm
 BIT. CONC. SURF. COURSE, SUPERPAVE, MIX
 C, N50, 50 mm
 PAINT PAVT. MKG. - LINE 100 mm (SOLID
 YELLOW ☉)

STA. 22+155
 PIPE CULVERT, TYPE 1, RCCP, 300 mm, 6.0 m
 REINFORCED CONCRETE FES, 300 mm, 2 EA.
 INV. (E) = 199.80
 INV. (W) = 199.65

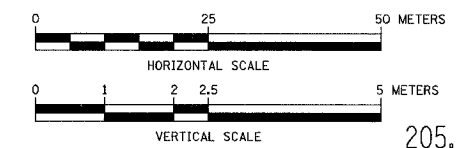

FOR LEGEND SEE SHEET NO. 15

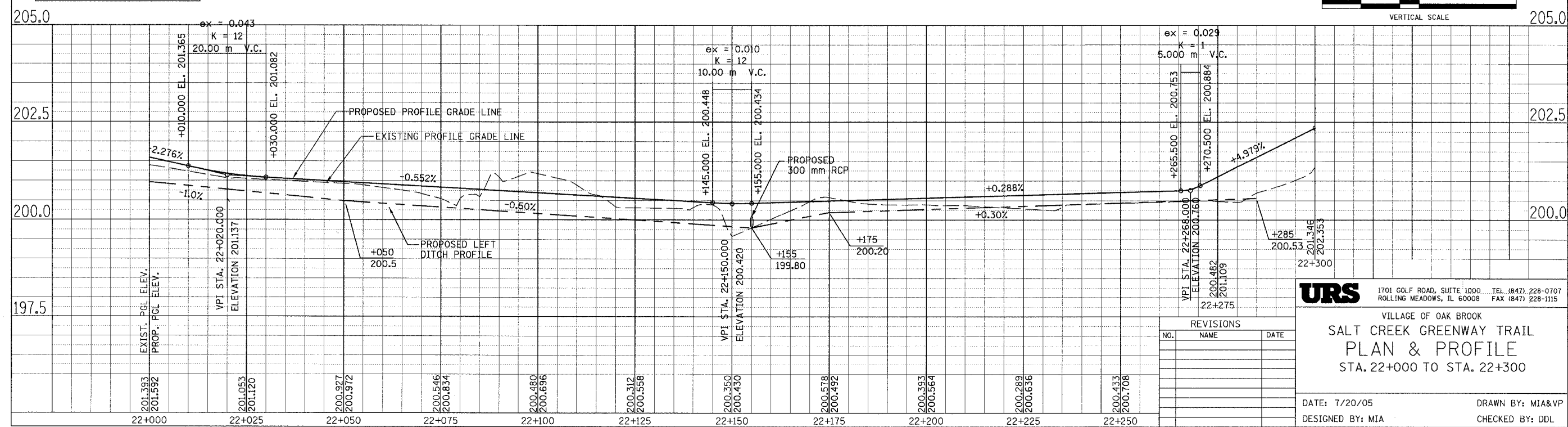

URS 1701 GOLF ROAD, SUITE 1000 TEL (847) 228-0707
 ROLLING MEADOWS, IL 60008 FAX (847) 228-1115

VILLAGE OF OAK BROOK
**SALT CREEK GREENWAY TRAIL
 PLAN & PROFILE**
 STA. 22+000 TO STA. 22+300

DATE: 7/20/05 DRAWN BY: MIA&VP
 DESIGNED BY: MIA CHECKED BY: DDL

REVISIONS		
NO.	NAME	DATE

PROP. CURVE CL2-19
 PI STA = 22+315.434
 N = 41,903.903
 E = 7,716.918
 $\Delta = 28^\circ 18' 59''$ (RT)
 R = 30.000 m
 T = 7.568 m
 L = 14.826 m
 E = 0.940 m

PROP. CURVE CL2-20
 PI STA = 22+346.506
 N = 41,876.354
 E = 7,731.945
 $\Delta = 41^\circ 11' 36''$ (RT)
 R = 30.000 m
 T = 11.274 m
 L = 21.569 m
 E = 2.049 m

SECTION	COUNTY	TOTAL SHEETS	SHEET NO.
02-00034-00-BT	DUPAGE	108	19
STA.	TO STA.		
IDOT PROJECT NO. M-8003(216)			
SALT CREEK GREENWAY TRAIL			
CONTRACT NO. 83714			

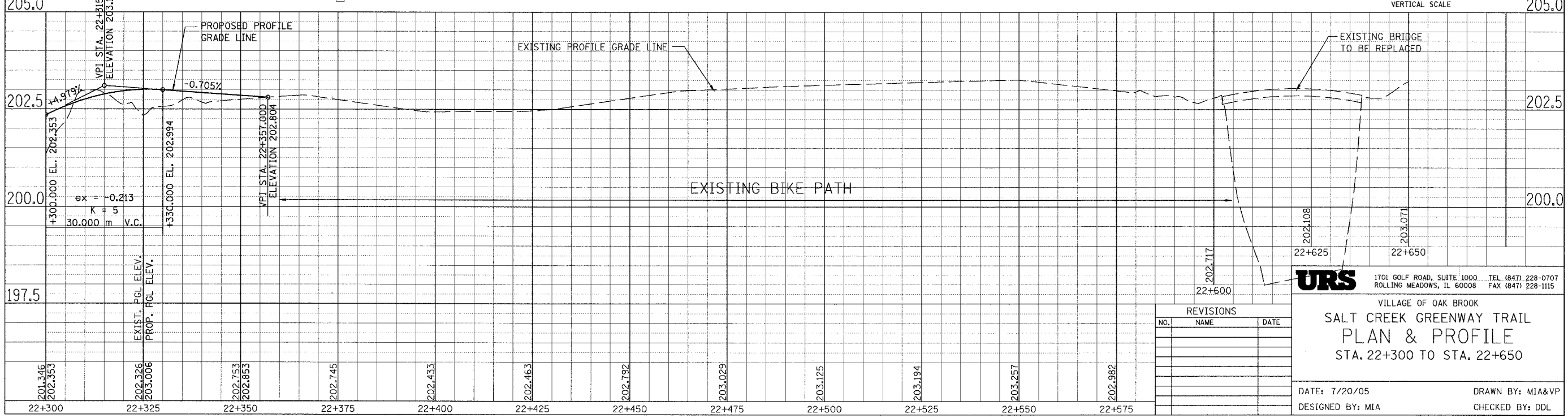
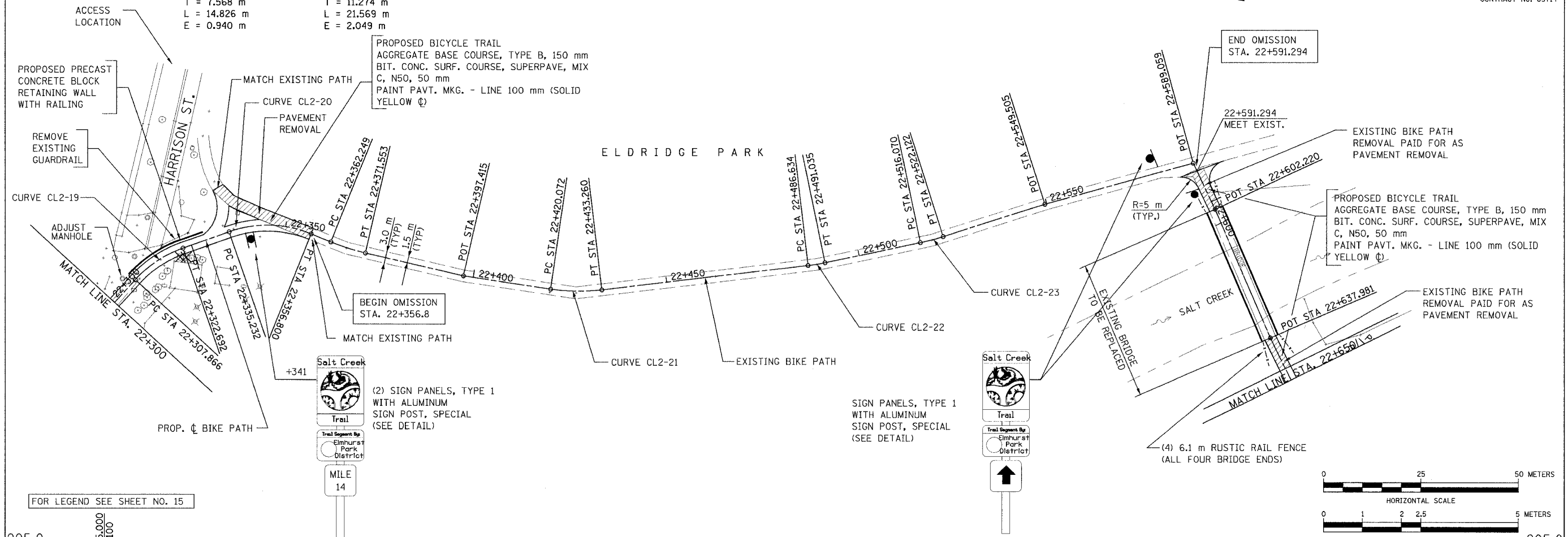

REVISIONS		
NO.	NAME	DATE

URS 1701 GOLF ROAD, SUITE 1000 TEL (847) 228-0707
 ROLLING MEADOWS, IL 60008 FAX (847) 228-1115

VILLAGE OF OAK BROOK
SALT CREEK GREENWAY TRAIL
PLAN & PROFILE
 STA. 22+300 TO STA. 22+650

DATE: 7/20/05 DRAWN BY: MIA&VP
 DESIGNED BY: MIA CHECKED BY: DDL

SECTION	COUNTY	TOTAL SHEETS	SHEET NO.
02-00034-00-BT	DUPAGE	108	20
STA. TO STA.			
IDOT PROJECT NO. M-8003(216)			
SALT CREEK GREENWAY TRAIL			
CONTRACT NO. 83714			

PROP. CURVE CL2-25 PI STA = 22+697.989 N = 41,575.553 E = 7,725.592 $\Delta = 27^\circ 49' 28''$ (LT) R = 30.000 m T = 7.431 m L = 14.569 m E = 0.907 m	PROP. CURVE CL2-26 PI STA = 22+728.934 N = 41,558.864 E = 7,751.999 $\Delta = 7^\circ 56' 16''$ (LT) R = 30.000 m T = 2.081 m L = 4.156 m E = 0.072 m	PROP. CURVE CL2-27 PI STA = 22+750.040 N = 41,550.157 E = 7,771.232 $\Delta = 34^\circ 54' 42''$ (RT) R = 30.000 m T = 9.434 m L = 18.280 m E = 1.448 m	PROP. CURVE CL2-28 PI STA = 22+819.813 N = 41,489.677 E = 7,807.188 $\Delta = 76^\circ 27' 01''$ (RT) R = 35.000 m T = 27.567 m L = 46.701 m E = 9.553 m	PROP. CURVE CL2-29 PI STA = 22+888.490 N = 41,435.840 E = 7,751.984 $\Delta = 7^\circ 50' 21''$ (RT) R = 30.000 m T = 2.055 m L = 4.105 m E = 0.070 m	PROP. CURVE CL2-30 PI STA = 22+911.877 N = 41,421.944 E = 7,733.165 $\Delta = 29^\circ 10' 24''$ (LT) R = 30.000 m T = 7.807 m L = 15.275 m E = 0.999 m	PROP. CURVE CL2-31 PI STA = 22+928.705 N = 41,406.308 E = 7,726.078 $\Delta = 20^\circ 11' 02''$ (RT) R = 30.000 m T = 5.339 m L = 10.568 m E = 0.471 m	PROP. CURVE CL2-32 PI STA = 22+949.369 N = 41,391.507 E = 7,711.499 $\Delta = 90^\circ 26' 02''$ (LT) R = 5.000 m T = 5.038 m L = 7.892 m E = 2.098 m
--	--	--	---	--	--	--	--

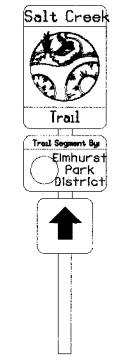

(A) SIGN PANELS, TYPE 1 WITH ALUMINUM SIGN POST, SPECIAL (SEE DETAIL)

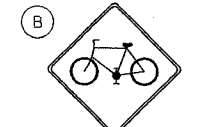

(B) W11-1 750 mm X 750 mm (2) 4.25 m TY A POST (2) SIGNS 75 m ON BUTTERFIELD IN ADVANCE OF INTERSECTION

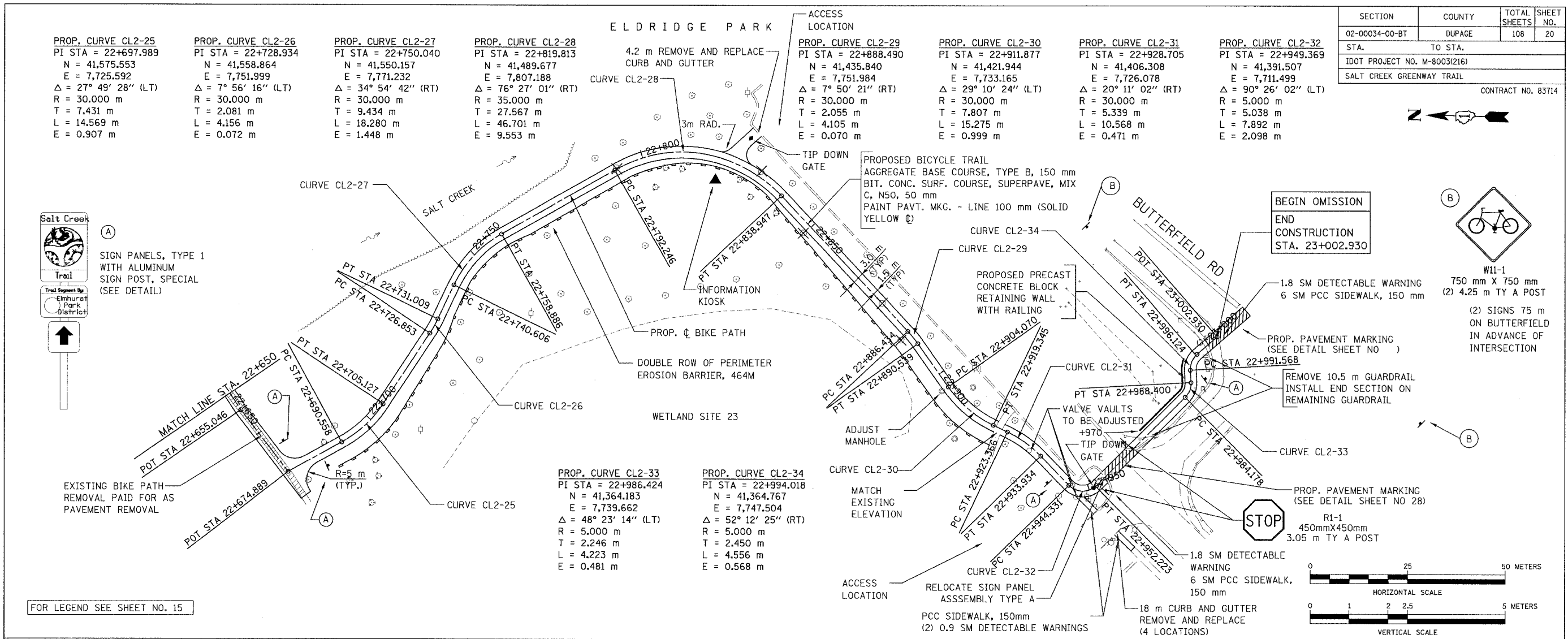

FOR LEGEND SEE SHEET NO. 15

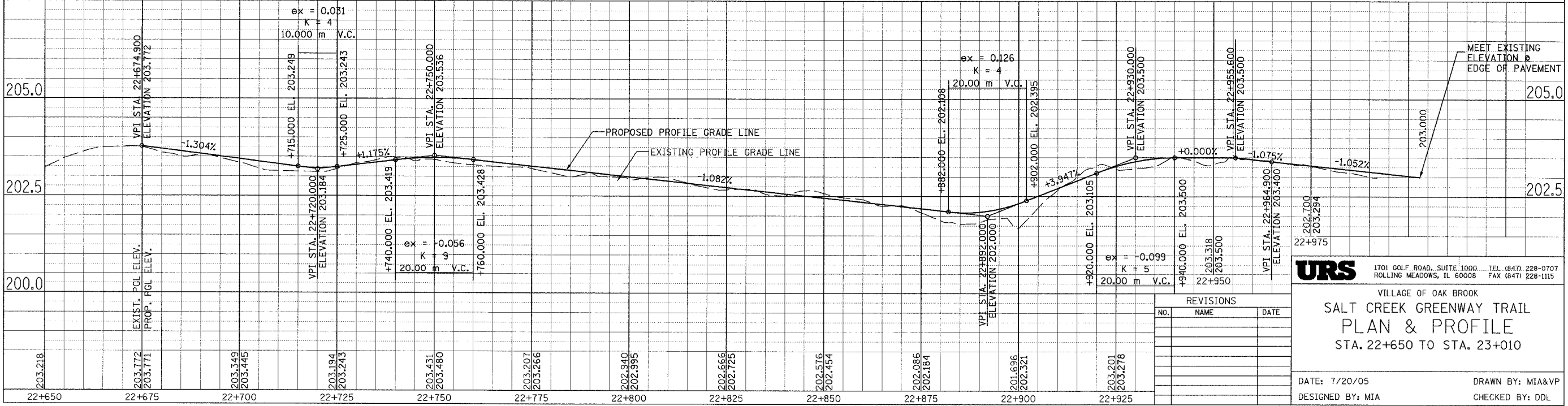

URS 1701 GOLF ROAD, SUITE 1000 TEL (847) 228-0707
 ROLLING MEADOWS, IL 60008 FAX (847) 228-1115

VILLAGE OF OAK BROOK
SALT CREEK GREENWAY TRAIL
PLAN & PROFILE
 STA. 22+650 TO STA. 23+010

REVISIONS		
NO.	NAME	DATE

DATE: 7/20/05 DRAWN BY: MIA&VP
 DESIGNED BY: MIA CHECKED BY: DDL

SECTION	COUNTY	TOTAL SHEETS	SHEET NO.
02-00034-00-BT	DUPAGE	108	21
STA.	TO STA.		
IDOT PROJECT NO. M-8003(216)			
SALT CREEK GREENWAY TRAIL			
CONTRACT NO. 83714			

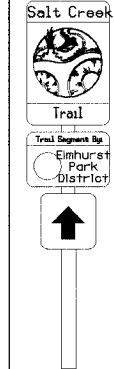
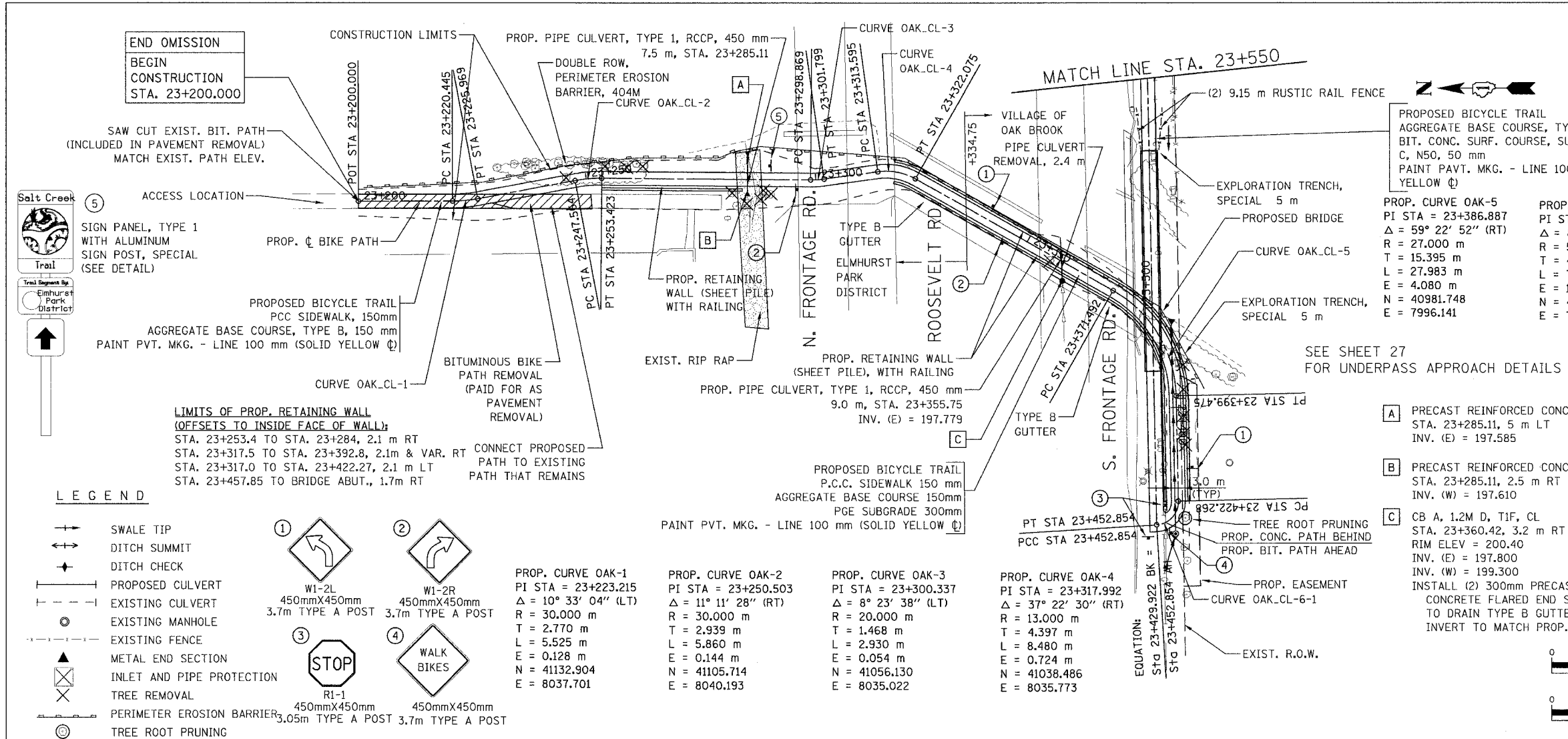

END OMISSION
BEGIN CONSTRUCTION
STA. 23+200.000

ACCESS LOCATION

SIGN PANEL, TYPE 1 WITH ALUMINUM SIGN POST, SPECIAL (SEE DETAIL)

PROPOSED BICYCLE TRAIL
PCC SIDEWALK, 150mm
AGGREGATE BASE COURSE, TYPE B, 150 mm
PAINT PVT. MKG. - LINE 100 mm (SOLID YELLOW ☐)

LIMITS OF PROP. RETAINING WALL (OFFSETS TO INSIDE FACE OF WALL):
STA. 23+253.4 TO STA. 23+284.2, 2.1 m RT
STA. 23+317.5 TO STA. 23+392.8, 2.1m & VAR. RT
STA. 23+317.0 TO STA. 23+422.27, 2.1 m LT
STA. 23+457.85 TO BRIDGE ABUT., 1.7m RT

LEGEND

- SWALE TIP
- DITCH SUMMIT
- DITCH CHECK
- PROPOSED CULVERT
- EXISTING CULVERT
- EXISTING MANHOLE
- EXISTING FENCE
- METAL END SECTION
- INLET AND PIPE PROTECTION
- TREE REMOVAL
- PERIMETER EROSION BARRIER
- TREE ROOT PRUNING

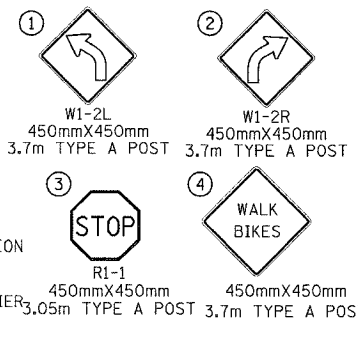

PROP. CURVE OAK-1 PI STA = 23+223.215 Δ = 10° 33' 04" (LT) R = 30.000 m T = 2.770 m L = 5.525 m E = 0.128 m N = 41132.904 E = 8037.701	PROP. CURVE OAK-2 PI STA = 23+250.503 Δ = 11° 11' 28" (RT) R = 30.000 m T = 2.939 m L = 5.860 m E = 0.144 m N = 41105.714 E = 8040.193	PROP. CURVE OAK-3 PI STA = 23+300.337 Δ = 8° 23' 38" (LT) R = 20.000 m T = 1.468 m L = 2.930 m E = 0.054 m N = 41056.130 E = 8035.022	PROP. CURVE OAK-4 PI STA = 23+317.992 Δ = 37° 22' 30" (RT) R = 13.000 m T = 4.397 m L = 8.480 m E = 0.724 m N = 41038.486 E = 8035.773
--	--	---	--

PROPOSED BICYCLE TRAIL
AGGREGATE BASE COURSE, TYPE B, 150 mm
BIT. CONC. SURF. COURSE, SUPERPAVE, MIX C, N50, 50 mm
PAINT PVT. MKG. - LINE 100 mm (SOLID YELLOW ☐)

PROP. CURVE OAK-5 PI STA = 23+386.887 Δ = 59° 22' 52" (RT) R = 27.000 m T = 15.395 m L = 27.983 m E = 4.080 m N = 40981.748 E = 7996.141	PROP. CURVE OAK-6-1 PI STA = 23+427.072 Δ = 87° 42' 19" (RT) R = 5.000 m T = 4.804 m L = 7.654 m E = 1.934 m N = 40984.984 E = 7953.271	PROP. CURVE OAK-6-2 PI STA = 23+452.854 Δ = 0° 00' 08" (RT) R = 40989.785 E = 7953.441
--	---	--

SEE SHEET 27 FOR UNDERPASS APPROACH DETAILS

- A** PRECAST REINFORCED CONCRETE FES, 450 mm
STA. 23+285.11, 5 m LT
INV. (E) = 197.585
- B** PRECAST REINFORCED CONCRETE FES, 450 mm
STA. 23+285.11, 2.5 m RT
INV. (W) = 197.610
- C** CB A, 1.2M D, TIF, CL
STA. 23+360.42, 3.2 m RT
RIM ELEV = 200.40
INV. (E) = 197.800
INV. (W) = 199.300
INSTALL (2) 300mm PRECAST REINF. CONCRETE FLARED END SECTIONS TO DRAIN TYPE B GUTTER. INVERT TO MATCH PROP. GUTTER EL.

USE CAUTION AROUND 24" GAS LINE CONTACT NICOR PRIOR TO EXCAVATION

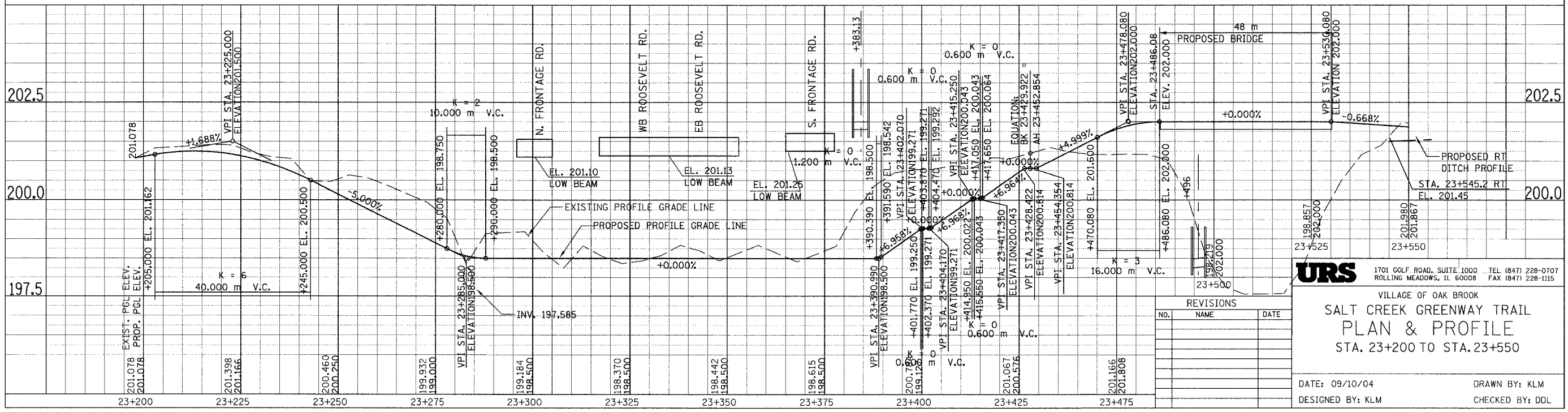
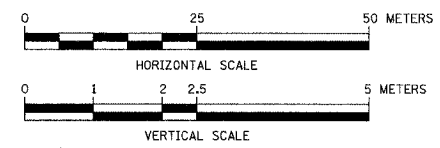

URS 1701 GOLF ROAD, SUITE 1000 TEL (847) 228-0707
ROLLING MEADOWS, IL 60008 FAX (847) 228-1115

VILLAGE OF OAK BROOK
SALT CREEK GREENWAY TRAIL
PLAN & PROFILE
STA. 23+200 TO STA. 23+550

DATE: 09/10/04 DRAWN BY: KLM
DESIGNED BY: KLM CHECKED BY: DDL

REVISIONS	
NO.	DATE

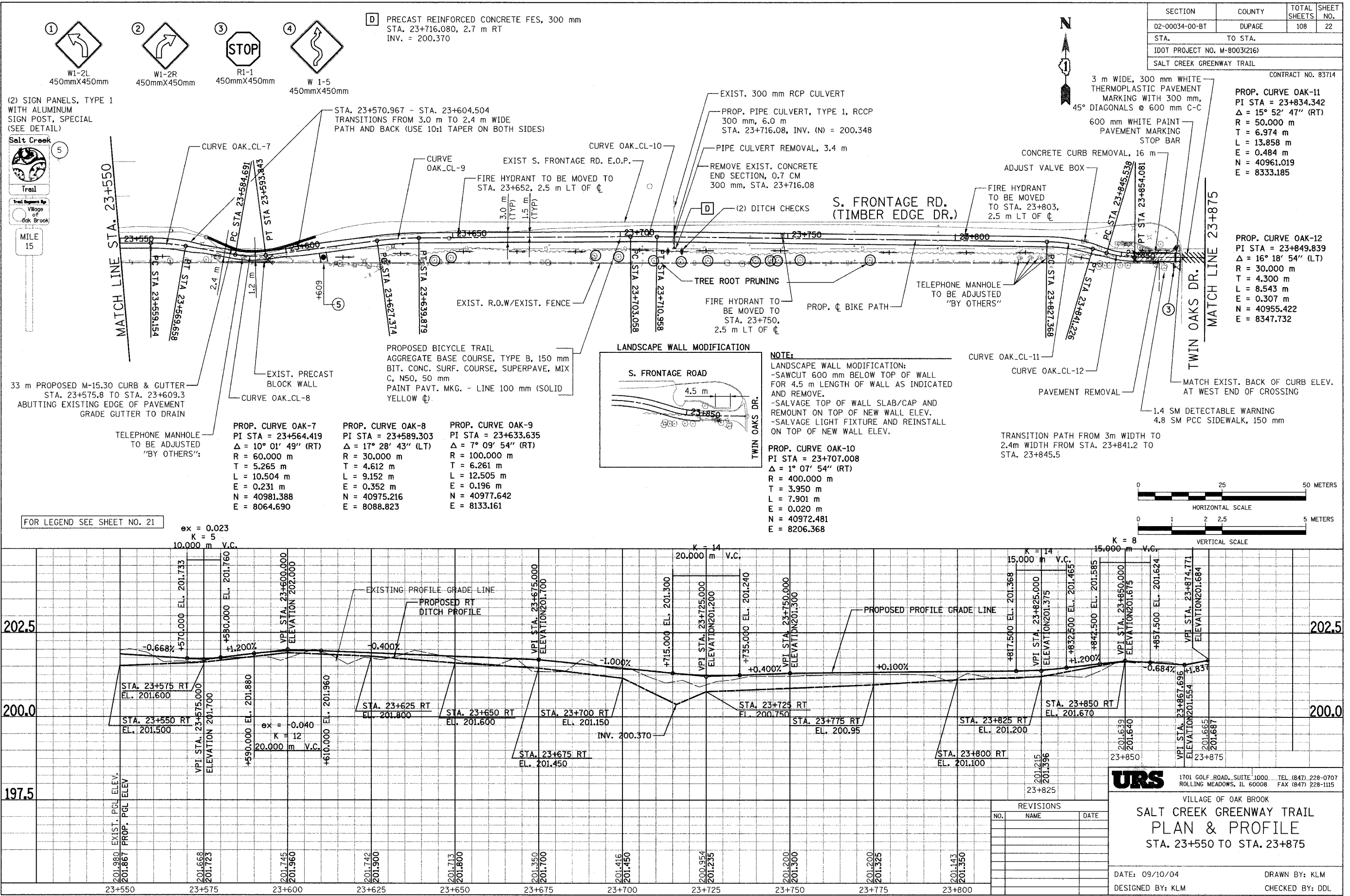

- ① W1-2L 450mmX450mm
- ② W1-2R 450mmX450mm
- ③ R1-1 450mmX450mm
- ④ W 1-5 450mmX450mm

D PRECAST REINFORCED CONCRETE FES, 300 mm
 STA. 23+716.080, 2.7 m RT
 INV. = 200.370

SECTION	COUNTY	TOTAL SHEETS	SHEET NO.
02-00034-00-BT	DUPAGE	108	22
STA. TO STA.			
IDOT PROJECT NO. M-8003(216)			
SALT CREEK GREENWAY TRAIL			

CONTRACT NO. 83714

PROP. CURVE OAK-11
 PI STA = 23+834.342
 $\Delta = 15^\circ 52' 47''$ (RT)
 R = 50,000 m
 T = 6,974 m
 L = 13,858 m
 E = 0.484 m
 N = 40961.019
 E = 8333.185

PROP. CURVE OAK-12
 PI STA = 23+849.839
 $\Delta = 16^\circ 18' 54''$ (LT)
 R = 30,000 m
 T = 4,300 m
 L = 8,543 m
 E = 0.307 m
 N = 40955.422
 E = 8347.732

(2) SIGN PANELS, TYPE 1 WITH ALUMINUM SIGN POST, SPECIAL (SEE DETAIL)



33 m PROPOSED M-15.30 CURB & GUTTER STA. 23+575.8 TO STA. 23+609.3 ABUTTING EXISTING EDGE OF PAVEMENT GRADE GUTTER TO DRAIN

PROP. CURVE OAK-7
 PI STA = 23+564.419
 $\Delta = 10^\circ 01' 49''$ (RT)
 R = 60,000 m
 T = 5,265 m
 L = 10,504 m
 E = 0.231 m
 N = 40981.388
 E = 8064.690

PROP. CURVE OAK-8
 PI STA = 23+589.303
 $\Delta = 17^\circ 28' 43''$ (LT)
 R = 30,000 m
 T = 4,612 m
 L = 9,152 m
 E = 0.352 m
 N = 40975.216
 E = 8088.823

PROP. CURVE OAK-9
 PI STA = 23+633.635
 $\Delta = 7^\circ 09' 54''$ (RT)
 R = 100,000 m
 T = 6,261 m
 L = 12,505 m
 E = 0.196 m
 N = 40977.642
 E = 8133.161

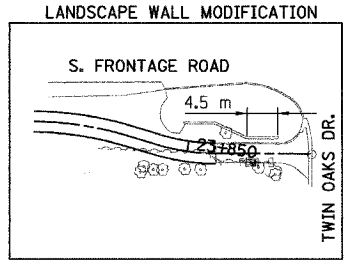

NOTE:
 LANDSCAPE WALL MODIFICATION:
 -SAWCUT 600 mm BELOW TOP OF WALL FOR 4.5 m LENGTH OF WALL AS INDICATED AND REMOVE.
 -SALVAGE TOP OF WALL SLAB/CAP AND REMOUNT ON TOP OF NEW WALL ELEV.
 -SALVAGE LIGHT FIXTURE AND REINSTALL ON TOP OF NEW WALL ELEV.

PROP. CURVE OAK-10
 PI STA = 23+707.008
 $\Delta = 1^\circ 07' 54''$ (RT)
 R = 400,000 m
 T = 3,950 m
 L = 7,901 m
 E = 0.020 m
 N = 40972.481
 E = 8206.368

TRANSITION PATH FROM 3m WIDTH TO 2.4m WIDTH FROM STA. 23+841.2 TO STA. 23+845.5

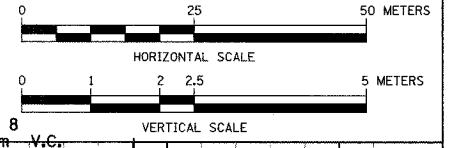

FOR LEGEND SEE SHEET NO. 21

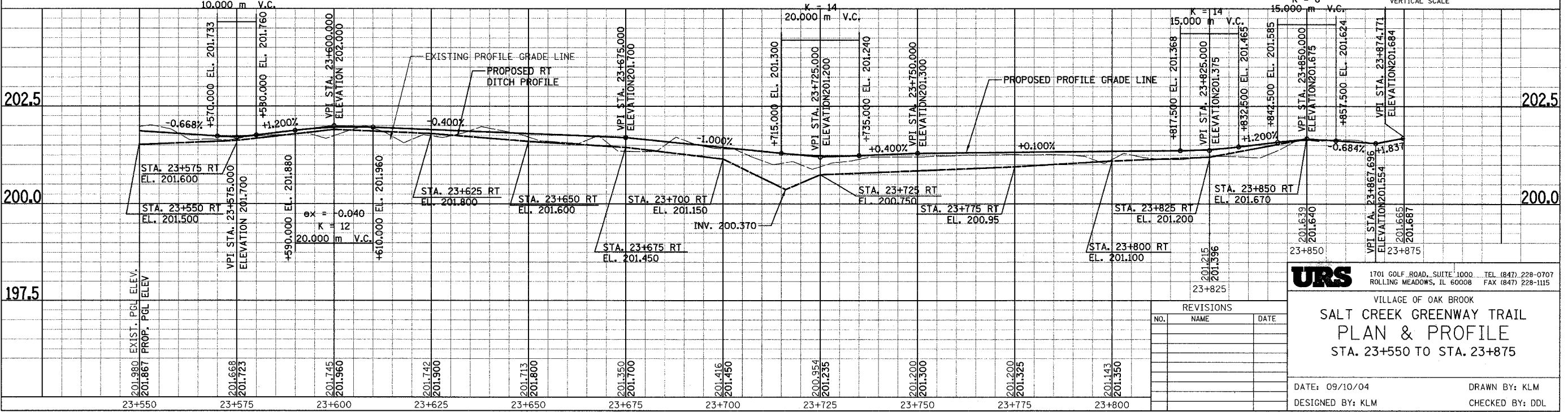

URS 1701 GOLF ROAD, SUITE 1000 TEL (847) 228-0707 ROLLING MEADOWS, IL 60008 FAX (847) 228-1115

VILLAGE OF OAK BROOK
**SALT CREEK GREENWAY TRAIL
 PLAN & PROFILE
 STA. 23+550 TO STA. 23+875**

DATE: 09/10/04 DRAWN BY: KLM
 DESIGNED BY: KLM CHECKED BY: DDL

REVISIONS		
NO.	NAME	DATE

SECTION	COUNTY	TOTAL SHEETS	SHEET NO.
02-00034-00-BT	DUPAGE	108	23
STA. TO STA.			
IDOT PROJECT NO. M-8003(216)			
SALT CREEK GREENWAY TRAIL			
CONTRACT NO. 83714			

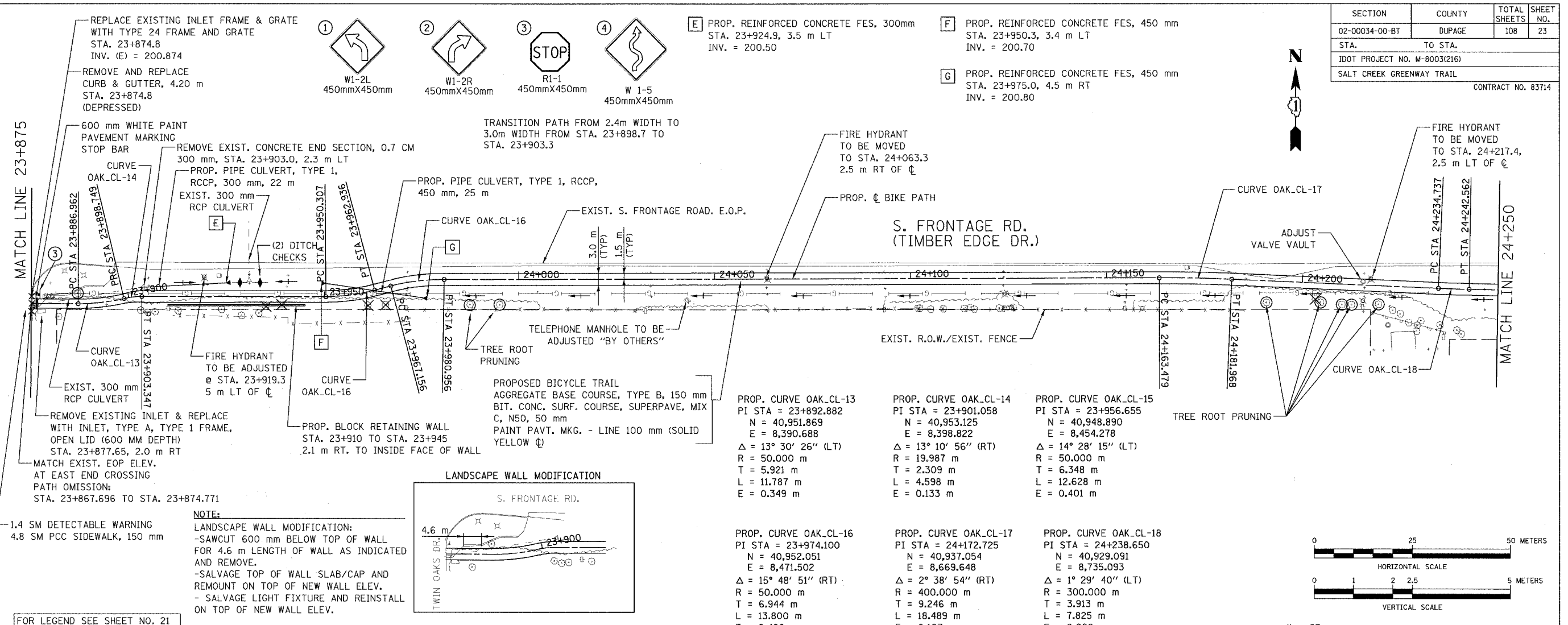

- E** PROP. REINFORCED CONCRETE FES, 300mm STA. 23+924.9, 3.5 m LT INV. = 200.50
- F** PROP. REINFORCED CONCRETE FES, 450 mm STA. 23+950.3, 3.4 m LT INV. = 200.70
- G** PROP. REINFORCED CONCRETE FES, 450 mm STA. 23+975.0, 4.5 m RT INV. = 200.80

NOTE:
 LANDSCAPE WALL MODIFICATION:
 -SAWCUT 600 mm BELOW TOP OF WALL FOR 4.6 m LENGTH OF WALL AS INDICATED AND REMOVE.
 -SALVAGE TOP OF WALL SLAB/CAP AND REMOUNT ON TOP OF NEW WALL ELEV.
 - SALVAGE LIGHT FIXTURE AND REINSTALL ON TOP OF NEW WALL ELEV.

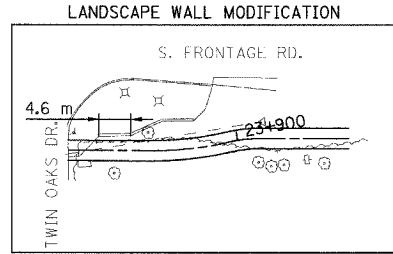

- PROP. CURVE OAK_CL-13
 PI STA = 23+892.882
 N = 40,951.869
 E = 8,390.688
 $\Delta = 13^\circ 30' 26''$ (LT)
 R = 50,000 m
 T = 5.921 m
 L = 11.787 m
 E = 0.349 m
- PROP. CURVE OAK_CL-14
 PI STA = 23+901.058
 N = 40,953.125
 E = 8,398.822
 $\Delta = 13^\circ 10' 56''$ (RT)
 R = 19,987 m
 T = 2.309 m
 L = 4.598 m
 E = 0.133 m
- PROP. CURVE OAK_CL-15
 PI STA = 23+956.655
 N = 40,948.890
 E = 8,454.278
 $\Delta = 14^\circ 28' 15''$ (LT)
 R = 50,000 m
 T = 6.348 m
 L = 12.628 m
 E = 0.401 m
- PROP. CURVE OAK_CL-16
 PI STA = 23+974.100
 N = 40,952.051
 E = 8,471.502
 $\Delta = 15^\circ 48' 51''$ (RT)
 R = 50,000 m
 T = 6.944 m
 L = 13.800 m
 E = 0.480 m
- PROP. CURVE OAK_CL-17
 PI STA = 24+172.725
 N = 40,937.054
 E = 8,669.648
 $\Delta = 2^\circ 38' 54''$ (RT)
 R = 400,000 m
 T = 9.246 m
 L = 18.489 m
 E = 0.107 m
- PROP. CURVE OAK_CL-18
 PI STA = 24+238.650
 N = 40,929.091
 E = 8,735.093
 $\Delta = 1^\circ 29' 40''$ (LT)
 R = 300,000 m
 T = 3.913 m
 L = 7.825 m
 E = 0.026 m

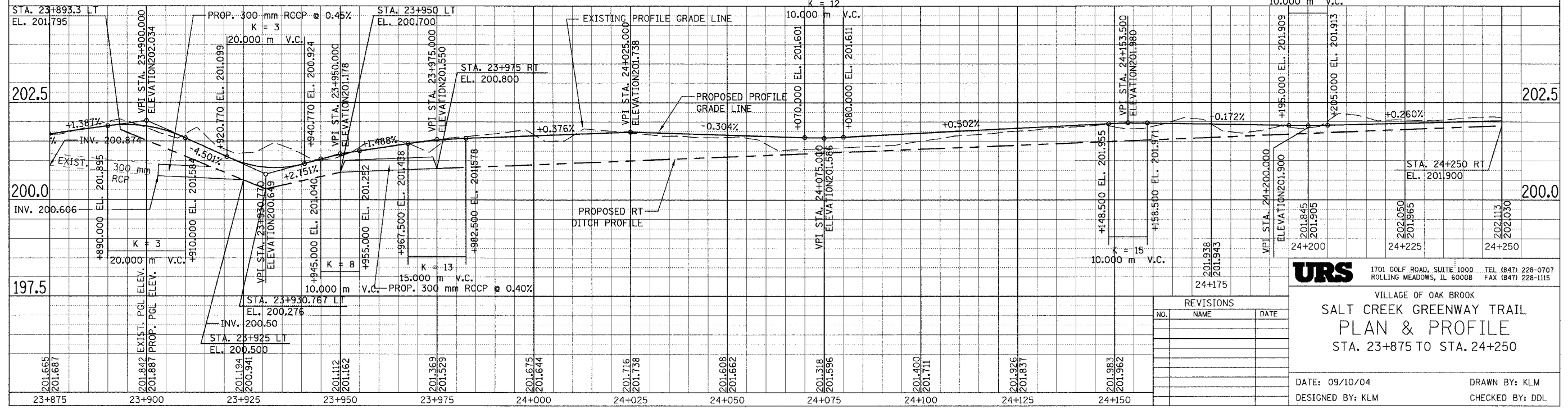
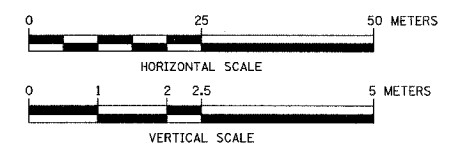

URS 1701 GOLF ROAD, SUITE 1000 TEL (847) 228-0707
 ROLLING MEADOWS, IL 60008 FAX (847) 228-1115

VILLAGE OF OAK BROOK
**SALT CREEK GREENWAY TRAIL
 PLAN & PROFILE
 STA. 23+875 TO STA. 24+250**

DATE: 09/10/04 DRAWN BY: KLM
 DESIGNED BY: KLM CHECKED BY: DDL

REVISIONS		
NO.	NAME	DATE

SECTION	COUNTY	TOTAL SHEETS	SHEET NO.
02-00034-00-BT	DUPAGE	108	24
STA.	TO STA.		
IDOT PROJECT NO. M-8003(216)			
SALT CREEK GREENWAY TRAIL			
CONTRACT NO. 83714			

PROP. CURVE OAK.CL-19
 PI STA = 24+286.458
 N = 40,924.566
 E = 8,782.686
 $\Delta = 2^\circ 16' 46''$ (LT)
 R = 300.000 m
 T = 5.968 m
 L = 11.935 m
 E = 0.059 m

PROP. CURVE OAK.CL-20
 PI STA = 24+366.780
 N = 40,920.124
 E = 8,862.888
 $\Delta = 54^\circ 48' 24''$ (RT)
 R = 30.000 m
 T = 15.553 m
 L = 28.697 m
 E = 3.792 m

PROP. CURVE OAK.CL-25
 PI STA = 24+504.161
 N = 40,796.081
 E = 8,863.538
 $\Delta = 11^\circ 03' 46''$ (LT)
 R = 30.000 m
 T = 2.905 m
 L = 5.793 m
 E = 0.140 m

PROP. CURVE OAK.CL-26
 PI STA = 24+521.150
 N = 40,783.284
 E = 8,852.337
 $\Delta = 36^\circ 46' 27''$ (LT)
 R = 30.000 m
 T = 9.972 m
 L = 19.255 m
 E = 1.614 m

PROP. CURVE OAK.CL-27
 PI STA = 24+541.980
 N = 40,761.828
 E = 8,850.678
 $\Delta = 29^\circ 50' 13''$ (LT)
 R = 30.000 m
 T = 7.993 m
 L = 15.623 m
 E = 1.046 m

PROP. CURVE OAK.CL-28
 PI STA = 24+557.201
 N = 40,747.753
 E = 8,857.366
 $\Delta = 23^\circ 52' 35''$ (RT)
 R = 30.000 m
 T = 6.343 m
 L = 12.502 m
 E = 0.663 m

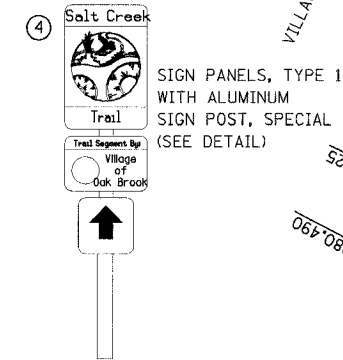

SIGN PANELS, TYPE 1 WITH ALUMINUM SIGN POST, SPECIAL (SEE DETAIL)

H PRECAST REINFORCED CONCRETE FES, 300 mm STA. 24+475. 3.5 m RT INV. = 200.930

I PRECAST REINFORCED CONCRETE FES, 300 mm STA. 24+475. 3.0 m LT INV. = 201.100

J PRECAST REINFORCED CONCRETE FES, 300 mm STA. 24+373. 2.75 m LT INV. = 201.90

K PRECAST REINFORCED CONCRETE FES, 300 mm STA. 24+373. 2.75 m LT INV. = 201.80

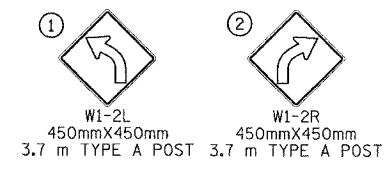

SIGN PANELS, TYPE 1 WITH ALUMINUM SIGN POST, SPECIAL (SEE DETAIL)

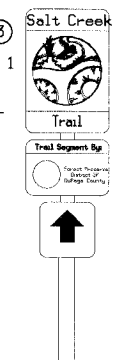

INSTALL SIGNS AT SHARP CURVE ON EXISTING TRAIL

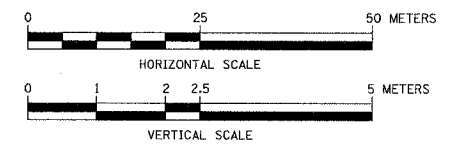

FOR LEGEND SEE SHEET NO. 21

VILLAGE OF OAK BROOK DISTRICT OF DUPAGE COUNTY
 FOREST PRESERVE
 S. FRONTAGE RD. (TIMBER EDGE DR.)
 MATCH LINE 24+250

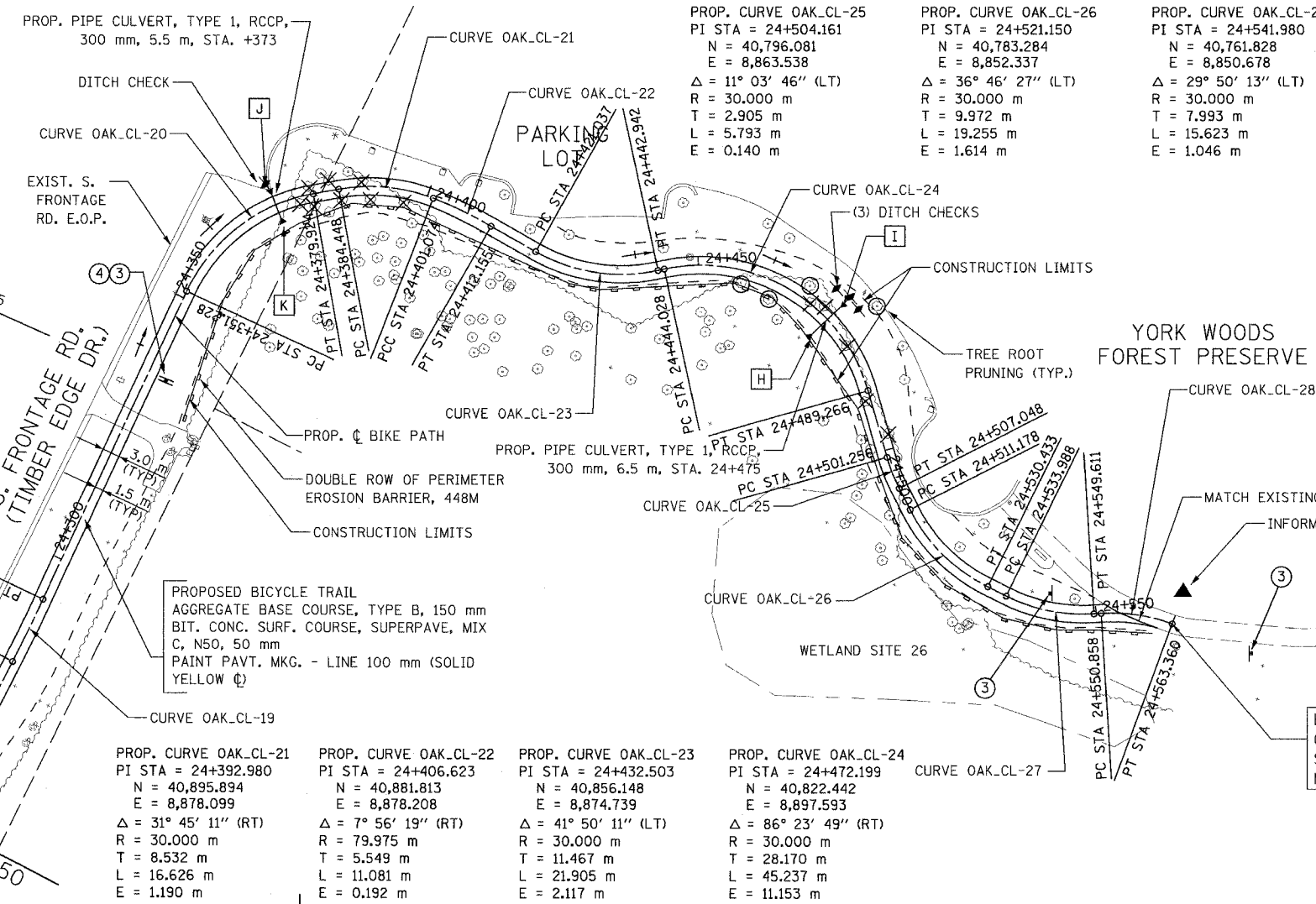

PROP. CURVE OAK.CL-21
 PI STA = 24+392.980
 N = 40,895.894
 E = 8,878.099
 $\Delta = 31^\circ 45' 11''$ (RT)
 R = 30.000 m
 T = 8.532 m
 L = 16.626 m
 E = 1.190 m

PROP. CURVE OAK.CL-22
 PI STA = 24+406.623
 N = 40,881.813
 E = 8,878.208
 $\Delta = 7^\circ 56' 19''$ (RT)
 R = 79.975 m
 T = 5.549 m
 L = 11.081 m
 E = 0.192 m

PROP. CURVE OAK.CL-23
 PI STA = 24+432.503
 N = 40,856.148
 E = 8,874.739
 $\Delta = 41^\circ 50' 11''$ (LT)
 R = 30.000 m
 T = 11.467 m
 L = 21.905 m
 E = 2.117 m

PROP. CURVE OAK.CL-24
 PI STA = 24+472.199
 N = 40,822.442
 E = 8,897.593
 $\Delta = 86^\circ 23' 49''$ (RT)
 R = 30.000 m
 T = 28.170 m
 L = 45.237 m
 E = 11.153 m

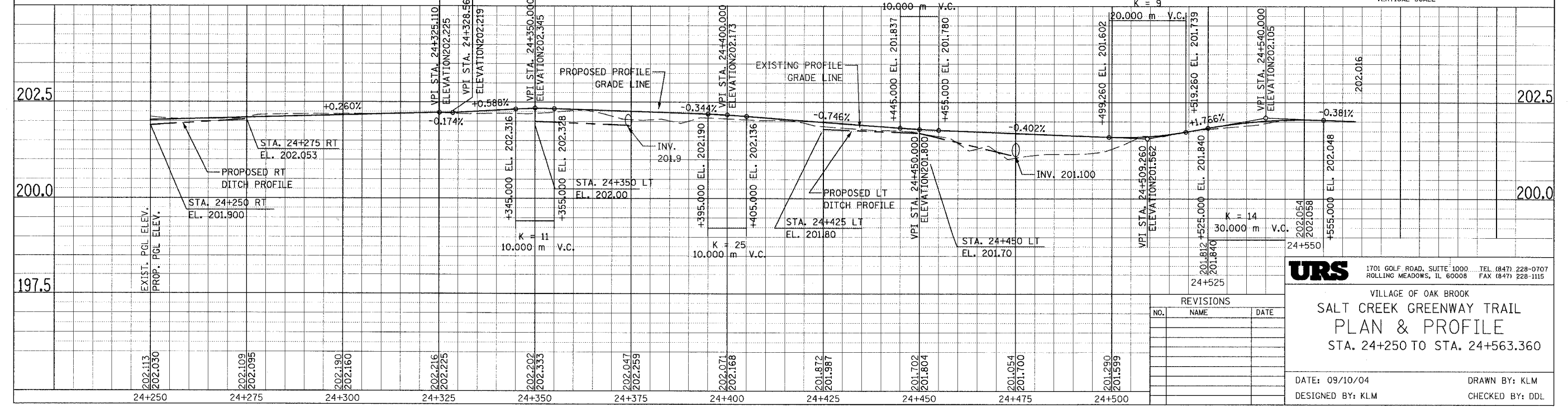

URS
 1701 GOLF ROAD, SUITE 1000 TEL (847) 228-0707
 ROLLING MEADOWS, IL 60008 FAX (847) 228-1115

VILLAGE OF OAK BROOK
 SALT CREEK GREENWAY TRAIL
 PLAN & PROFILE
 STA. 24+250 TO STA. 24+563.360

DATE: 09/10/04
 DESIGNED BY: KLM
 DRAWN BY: KLM
 CHECKED BY: DDL

REVISIONS		
NO.	NAME	DATE

SECTION	COUNTY	TOTAL SHEETS	SHEET NO.
02-00034-00-BT	DUPAGE	108	25
STA. TO STA.			
IDOT PROJECT NO. M-8003(216)			
SALT CREEK GREENWAY TRAIL			
CONTRACT NO. 83714			

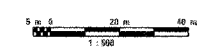
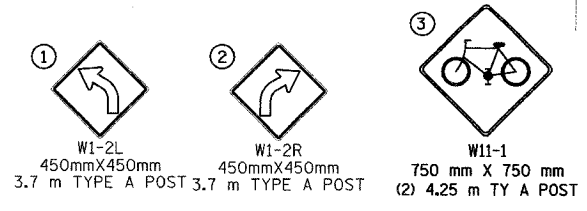
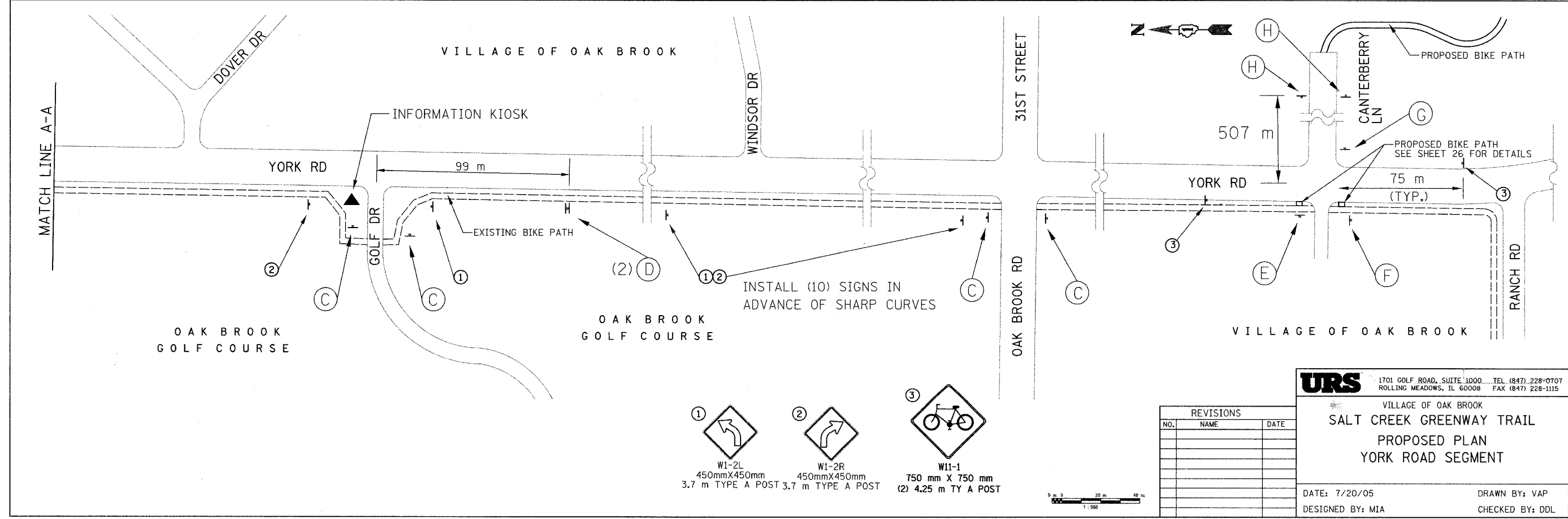
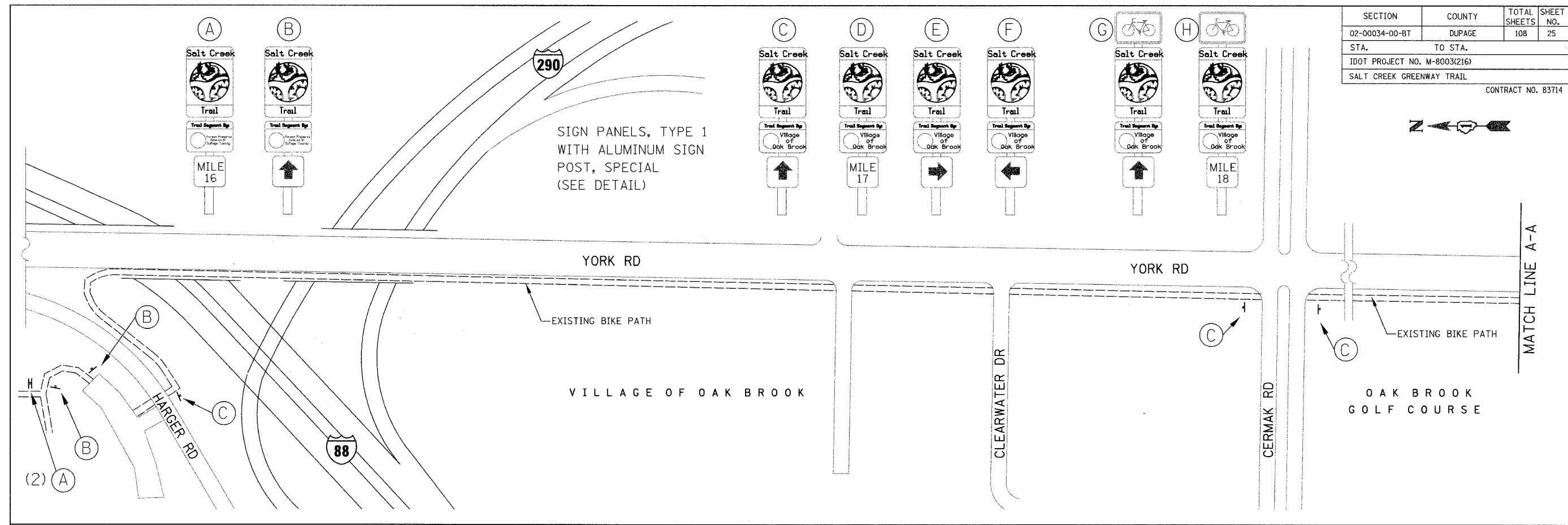

REVISIONS		
NO.	NAME	DATE

URS 1701 GOLF ROAD, SUITE 1000 TEL (847) 228-0707
ROLLING MEADOWS, IL 60008 FAX (847) 228-1115

VILLAGE OF OAK BROOK
SALT CREEK GREENWAY TRAIL
PROPOSED PLAN
YORK ROAD SEGMENT

DATE: 7/20/05 DRAWN BY: VAP
DESIGNED BY: MIA CHECKED BY: DDL

SECTION	COUNTY	TOTAL SHEETS	SHEET NO.
02-00034-00-BT	DUPAGE	108	27
STA. TO STA.			
IDOT PROJECT NO. M-8003(216)			
SALT CREEK GREENWAY TRAIL			
CONTRACT NO. 83714			



SIGN PANELS, TYPE 1 WITH ALUMINUM SIGN POST, SPECIAL (SEE DETAIL)

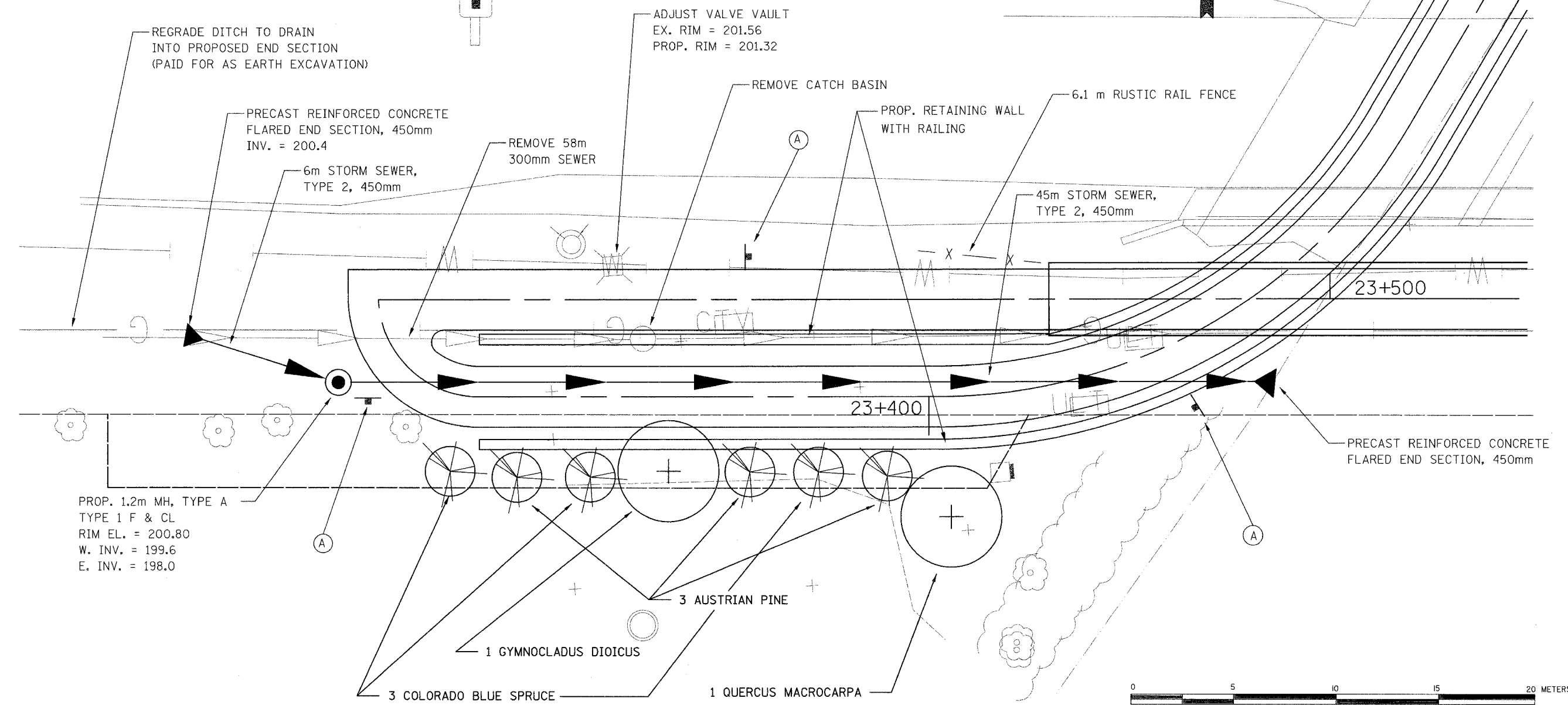

SCALE 1:100

URS 1701 GOLF ROAD, SUITE 1000 TEL (847) 228-0707 ROLLING MEADOWS, IL 60008 FAX (847) 228-1115

VILLAGE OF OAK BROOK
SALT CREEK GREENWAY TRAIL
UNDERPASS APPROACH DETAIL

REVISIONS		
NO.	NAME	DATE

DATE: 7/20/05 DRAWN BY: VAP
DESIGNED BY: MIA CHECKED BY: DDL

SECTION	COUNTY	TOTAL SHEETS	SHEET NO.
02-00034-00-BT	DUPAGE	108	28
STA.	TO STA.		
IDOT PROJECT NO. M-8003(216)			
SALT CREEK GREENWAY TRAIL			
CONTRACT NO. 83714			

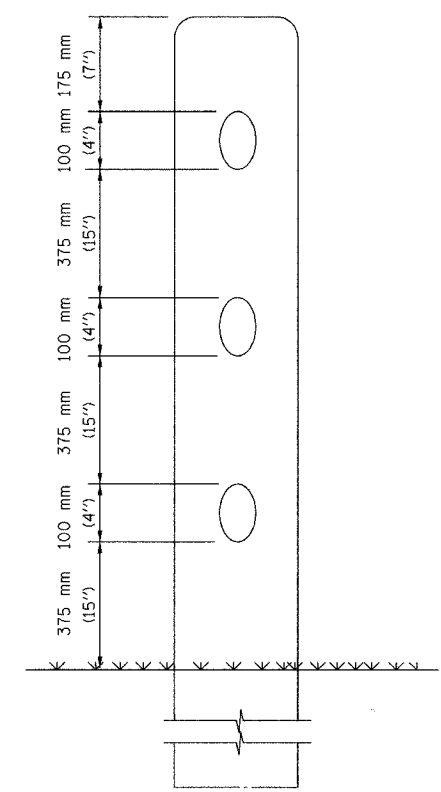

SIDE VIEW

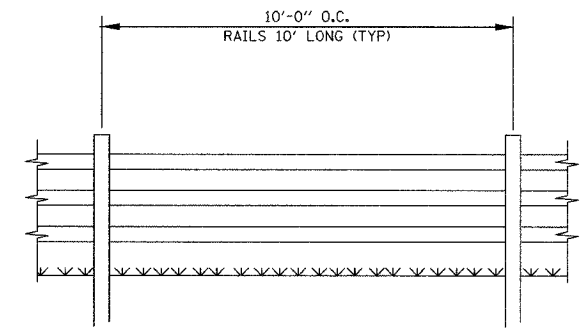

FRONT VIEW

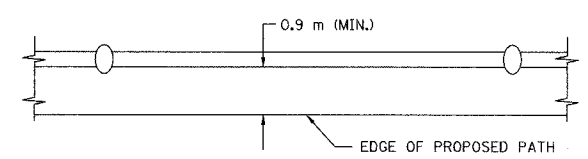

TOP VIEW

NOTE: ALL RAILS SHALL BE SPIKED TO POST W/GALVANIZED GUTTER SPIKES.

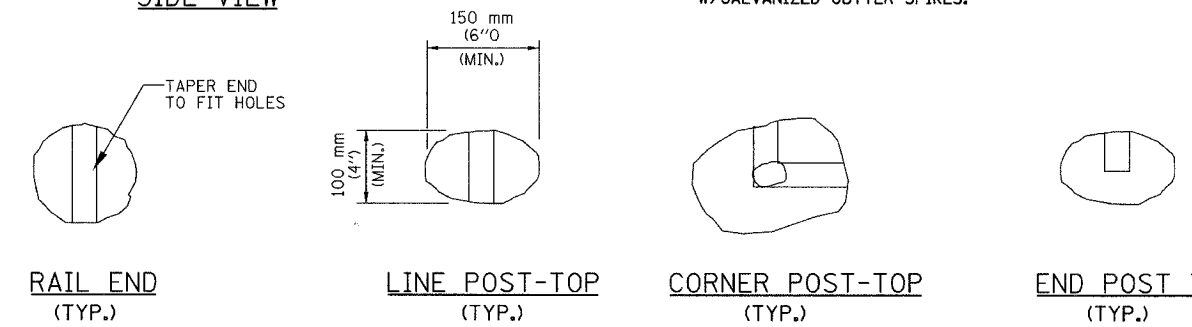

RUSTIC RAIL FENCE DETAIL

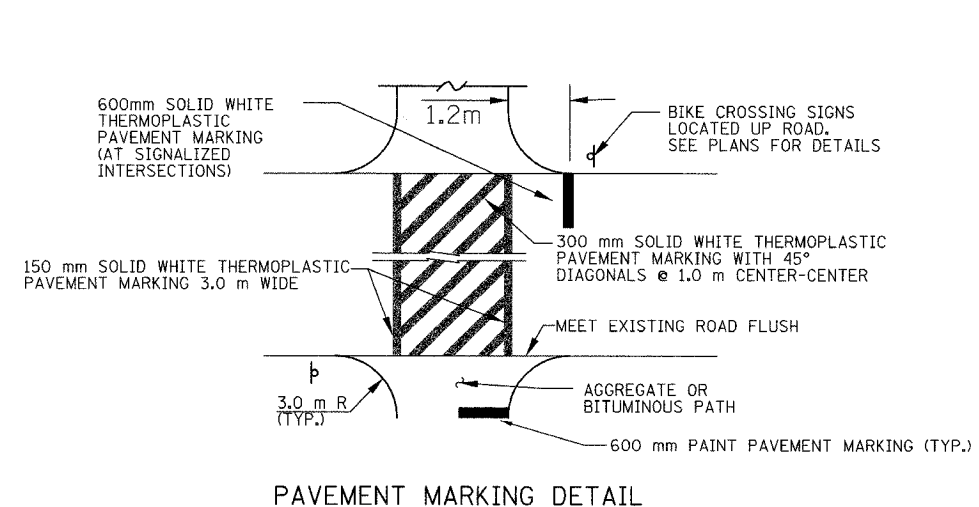

PAVEMENT MARKING DETAIL

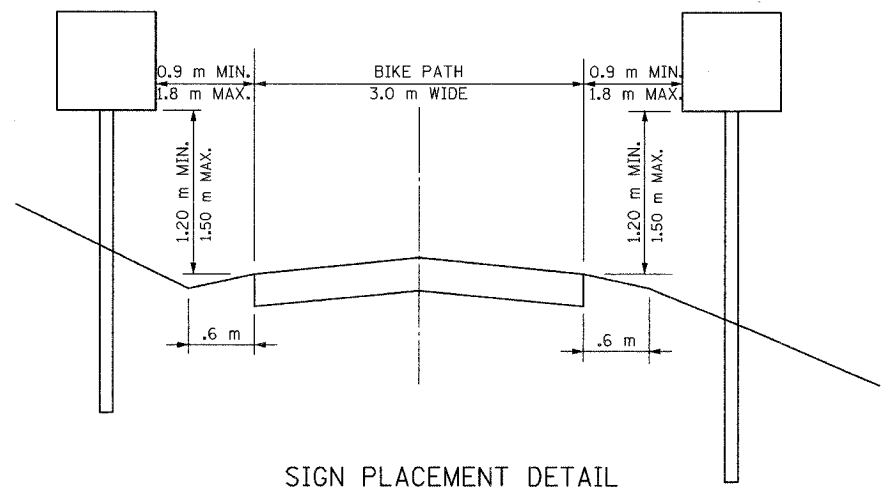

SIGN PLACEMENT DETAIL

REVISIONS		
NO.	NAME	DATE

URS 1701 GOLF ROAD, SUITE 1000 TEL (847) 228-0707
ROLLING MEADOWS, IL 60008 FAX (847) 228-1115

VILLAGE OF OAK BROOK
SALT CREEK GREENWAY TRAIL
MISCELLANEOUS DETAILS

DATE: 7/20/05 DRAWN BY: MIA&VP
DESIGNED BY: MIA CHECKED BY: DDL

SECTION	COUNTY	TOTAL SHEETS	SHEET NO.
02-00034-00-BT	DUPAGE	108	29
STA. TO STA.			
IDOT PROJECT NO. M-8003(216)			
SALT CREEK GREENWAY TRAIL			
CONTRACT NO. 83714			

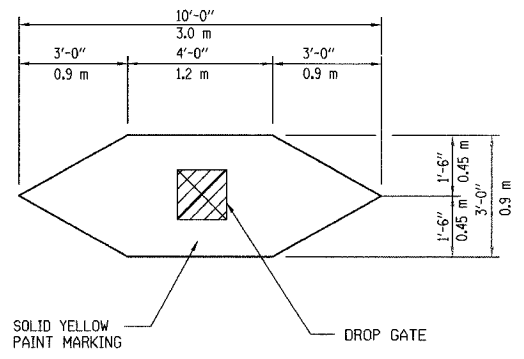

TIP DOWN GATE MARKING DETAIL
N.T.S.

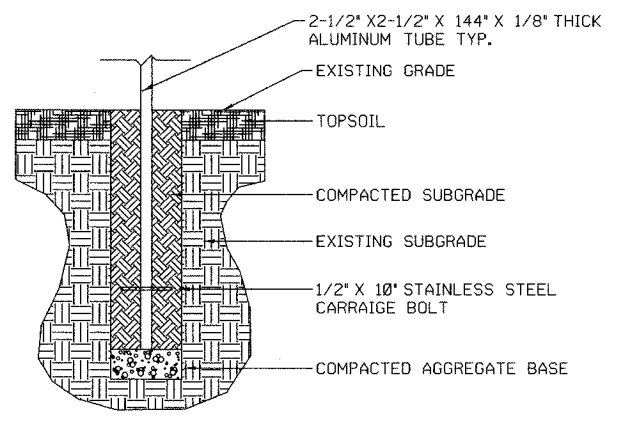

D4 SIGN BASE DETAIL
SECTION - N.T.S.

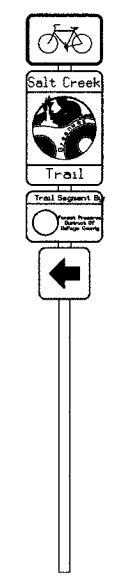

D6 TRAIL MARKER
DESIGN - N.T.S.

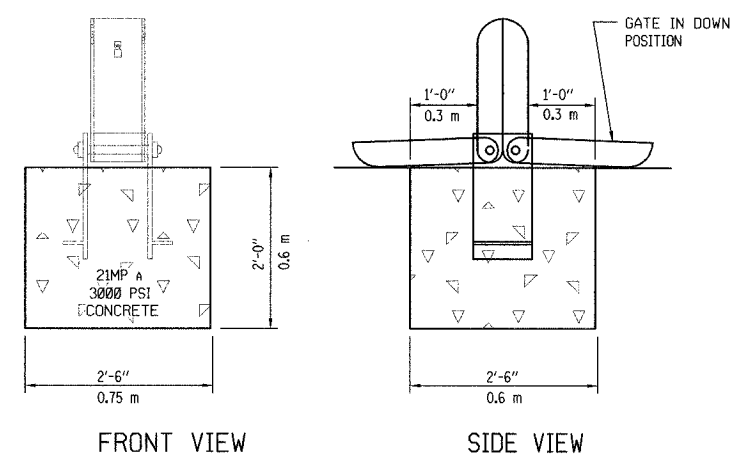

TIP DOWN GATE INSTALLATION DETAIL
N.T.S.

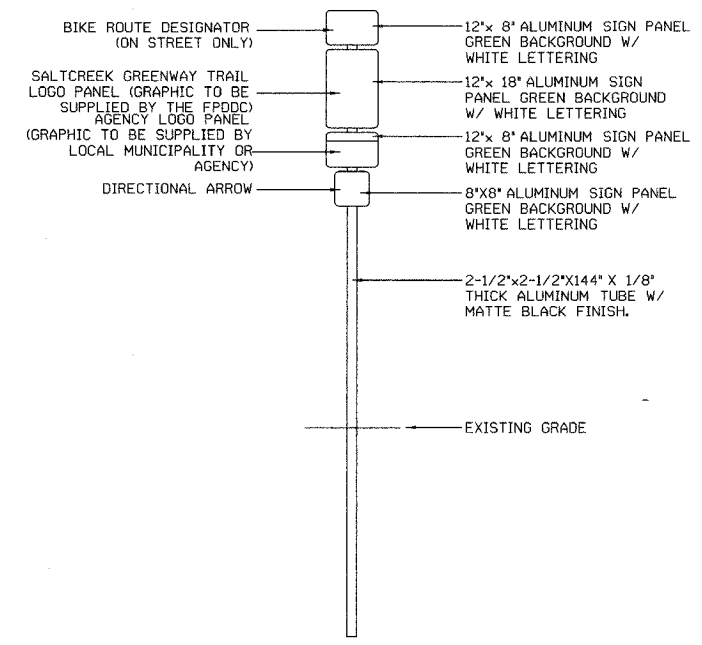

A6 TRAIL MARKER
ELEVATION - N.T.S.

REVISIONS		
NO.	NAME	DATE

URS 1701 GOLF ROAD, SUITE 1000 TEL. (847) 228-0707
ROLLING MEADOWS, IL 60008 FAX (847) 228-1115

VILLAGE OF OAK BROOK
SALT CREEK GREENWAY TRAIL
MISCELLANEOUS DETAILS

DATE: 7/20/05 DRAWN BY: MIA&VP
DESIGNED BY: MIA CHECKED BY: DDL

SECTION	COUNTY	TOTAL SHEETS	SHEET NO.
02-00034-00-BT	DUPAGE	108	30
STA.	TO STA.		
IDOT PROJECT NO. M-8003(216)			
SALT CREEK GREENWAY TRAIL			
CONTRACT NO. 83714			

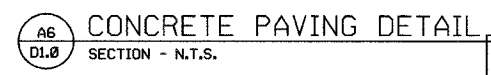
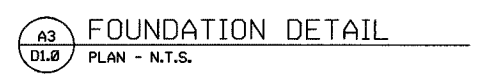
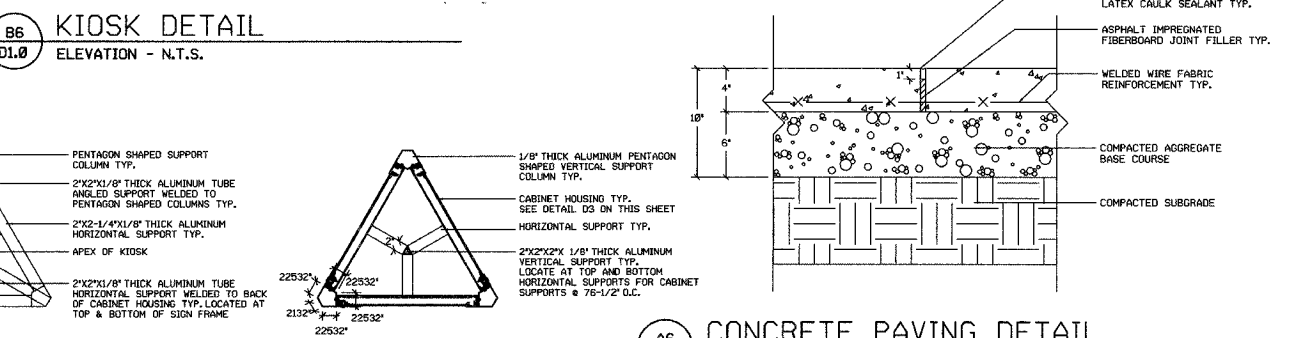
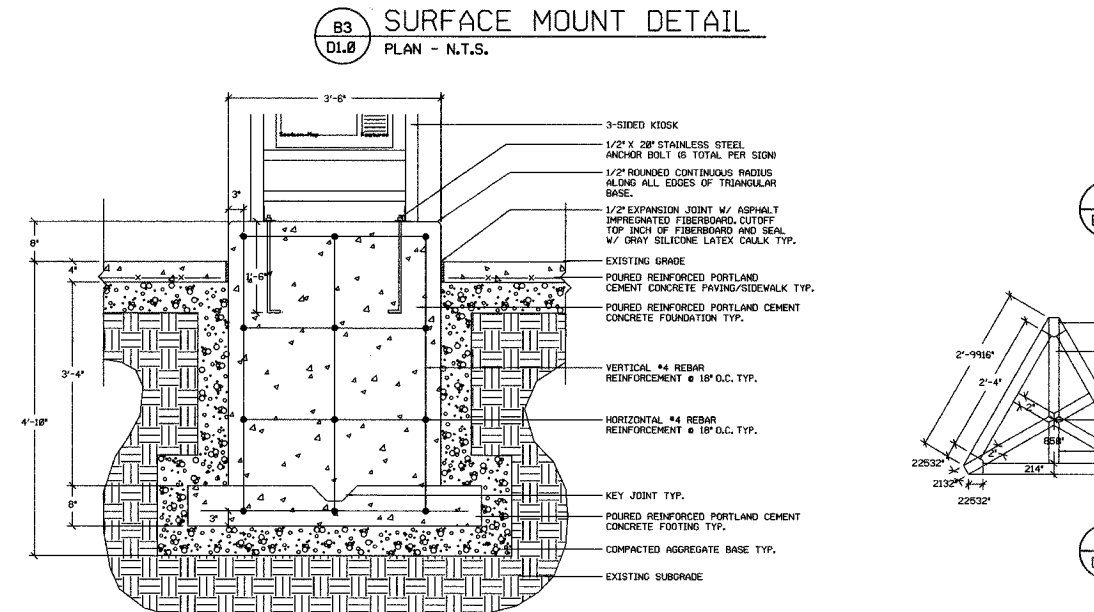
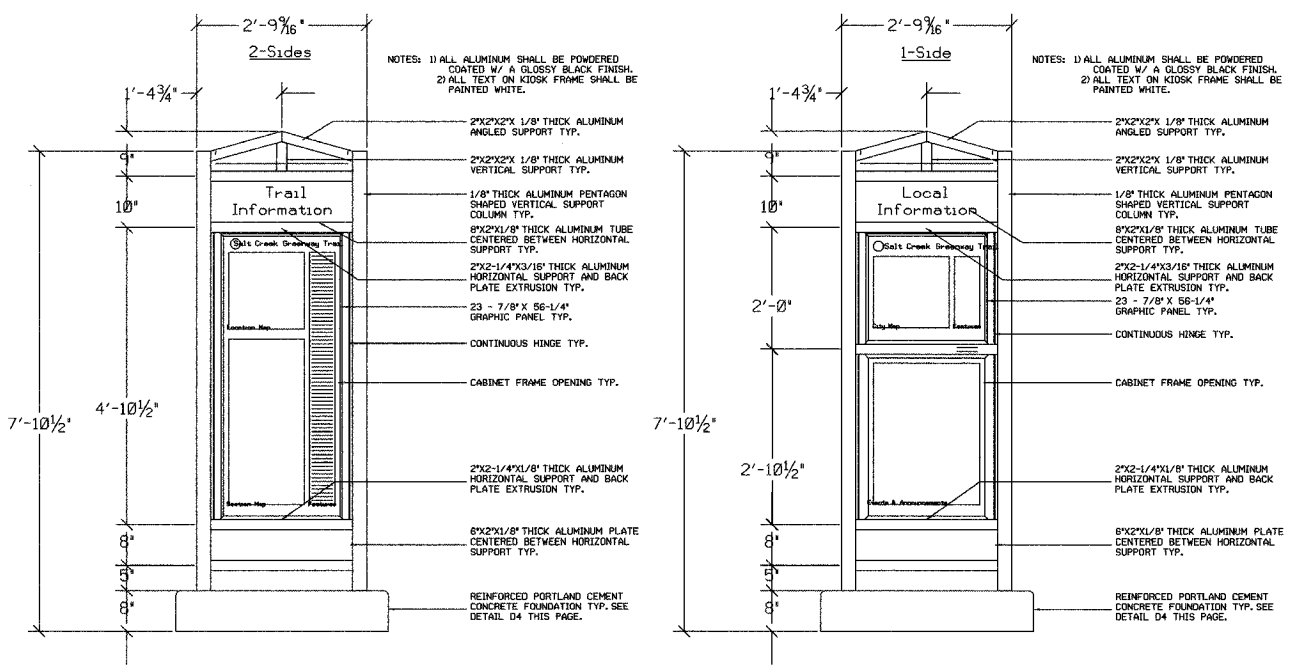
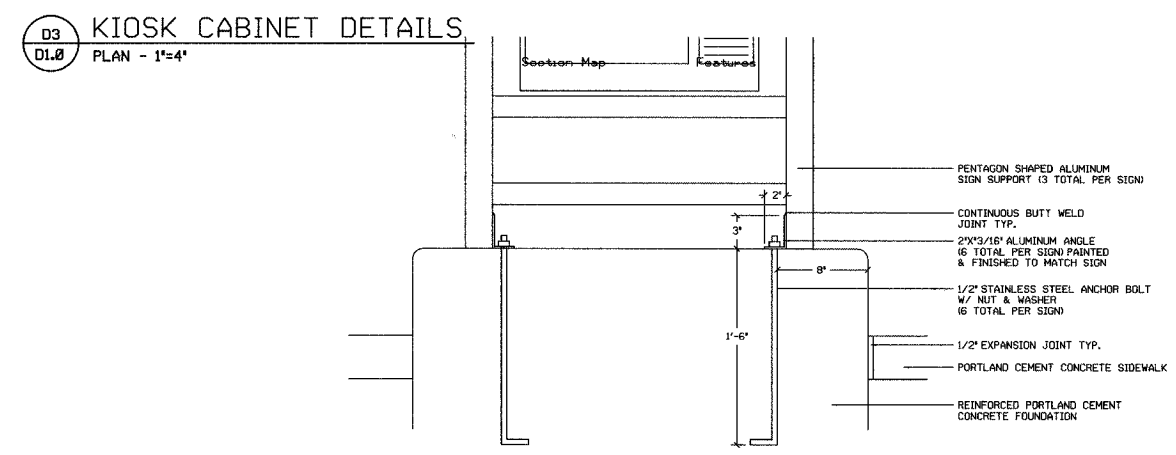
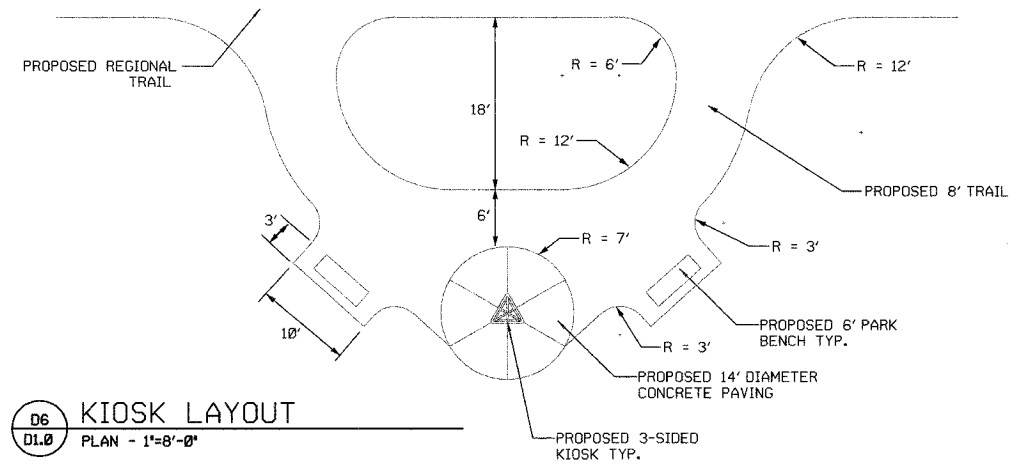
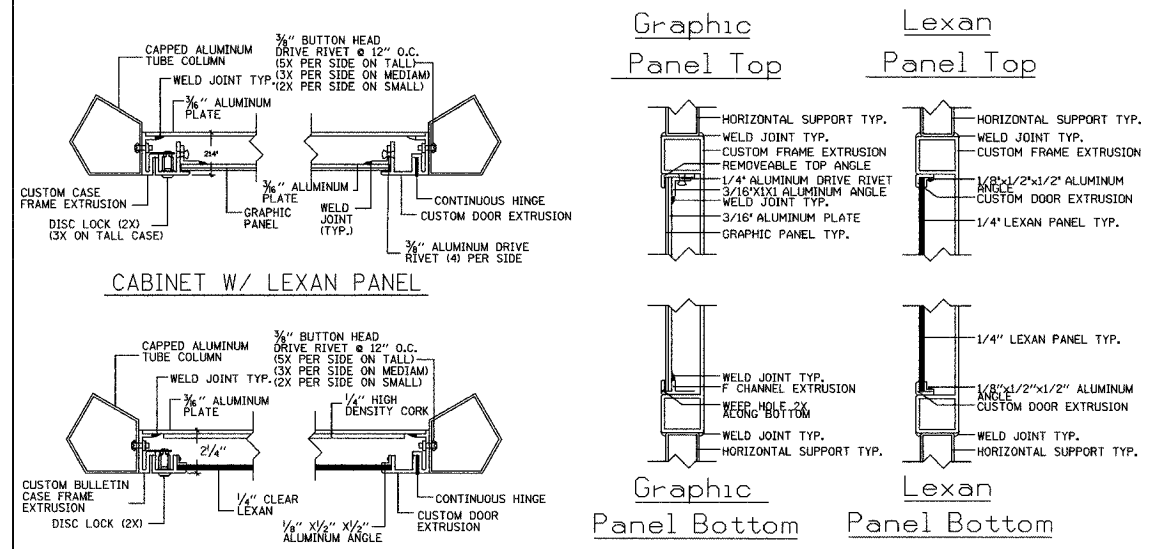

REVISIONS		
NO.	NAME	DATE

URS 1701 GOLF ROAD, SUITE 1000 TEL. (847) 228-0707
 ROLLING MEADOWS, IL 60008 FAX. (847) 228-1115

VILLAGE OF OAK BROOK
 SALT CREEK GREENWAY TRAIL
 INFORMATION KIOSK
 DETAILS

DATE: 7/20/05 DRAWN BY: MIA&VP
 DESIGNED BY: MIA CHECKED BY: DDL

SECTION	COUNTY	TOTAL SHEETS	SHEET NO.
02-00034-00-BT	DUPAGE	108	31
STA. TO STA.			
IDOT PROJECT NO. M-8003(216)			
SALT CREEK GREENWAY TRAIL			
CONTRACT NO. 83714			

VILLAGE OF ELMHURST

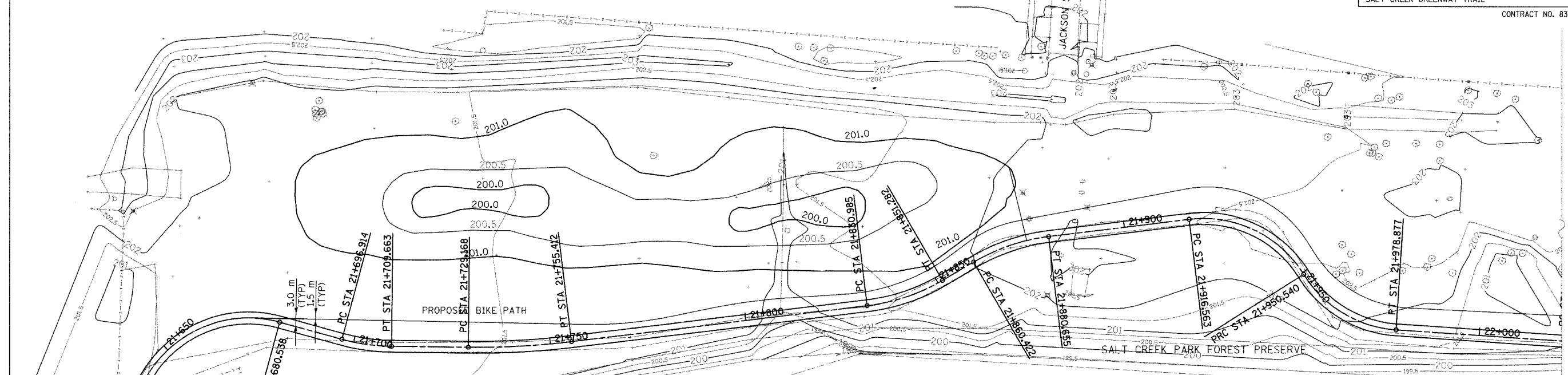

SITE PREPARATION

EXISTING VEGETATION REMOVAL

1. PRIOR TO ANY GRADING WORK ALL SPECIES DEEMED UNDESIRABLE BY THE USACOE STAFF SHALL BE SPRAYED WITH THE APPROPRIATE HERBICIDE AND CUT/REMOVED FROM THE WETLAND MITIGATION SITES, IF PRESENT, BUCKHORN AND ANY OTHER NON-NATIVE OR UNDESIRABLE WOODY SPECIES SHALL BE REMOVED BY CUTTING. THE CUTTING OF THESE SPECIES SHALL BE AT GROUND LEVEL AND FOLLOWED BY APPLICATION OF 20% SOLUTION OF GARLON-4A IN PENTAVATOR BASE OIL TO THE FRESH STUMP.
2. ALL SITE HERBACEOUS VEGETATION SHALL BE SPRAYED WITH A 50% SOLUTION OF ROUNDUP OR PODEO PRIOR TO GRADING.
3. ALL HERBICIDE APPLICATION SHALL BE COMPLETED UNDER THE DIRECTION OF A LICENCED APPLICATOR WITH LICENCED OPERATORS.

SOIL PREPARATION

1. FOLLOWING HERBICIDE APPLICATION AND REMOVAL OF UNDESIRABLE VEGETATION THE SOIL SHALL BE PREPARED BY GRADING THE SITE TO A DEPTH OF 150mm - 300mm DEPTH. TOPSOIL SHOULD BE STRIPPED AND RESPREAD TO A DEPTH OF 150mm FOLLOWING GRADING.
2. NO OTHER CONSTRUCTION MACHINERY OR ACTIVITY SHALL OCCUR ON THE WETLAND MITIGATION SITE FOLLOWING GRADING AND RESPREADING OF TOPSOIL IN ORDER TO MINIMIZE SOIL COMPACTION.

EROSION CONTROL

1. THE WETLAND MITIGATION SITE SHALL BE PROTECTED BY THE PLACEMENT OF SILT/EROSION CONTROL FENCING AROUND THE PERIMETER OF THE SITES IN ACCORDANCE WITH THE ILLINOIS PROCEDURE AND STANDARDS FOR URBAN SOIL EROSION AND SEDIMENTATION CONTROL. EROSION AND SEDIMENTATION CONTROL MEASURES SHALL BE CONSISTENT WITH THE PRACTICE, STANDARDS, AND SPECIFICATIONS IN MANUAL.
2. EROSION CONTROL MRESURES SHALL BE IN PLACE AND MAINTAINED DURING THE ENTIRE PERIOD OF THE RESTORATION CONSTRUCTION.
3. WEEKLY EROSION CONTROL SITE INPECTIONS SHALL BE PERFORMED DURING THE CONSTRUCTION PERIOD AND UNTIL THE SITE IS PERMANENTLY VEGETATED. IN ADDITION SITE INSECTIONS MUST BE COMPLETED WITHIN 24 HOURS OF A SIGNIFICANT STORM EVENT (>1"). A COPY OF REPORTS SHALL BE SUBMITTED TO THE USACOE-CHICAGO DISTRICT ON A MONTHLY BASIS.

SEEDING/PLANTING PROCEDURES

1. THE SEEDING/PLANTING IN THE WETLAND MITIGATION SITE SHALL BE SET FORTH IN THIS DOCUMENT, AS INDICATED IN THE PLANS, OR AS DIRECTED BY THE USACOE STAFF.
2. THE RESTORATION SEEDING/PLANTING SHALL BE ACCOMPLISHED WITH THE SPECIES QUANTITIES SPECIFIED IN THE ACCOMPANYING LIST. PROPOSED SUBSTITUTIONS SHALL BE REVIEWED AND APPROVED BY THE USACOE IN WRITING PRIOR TO PLANTING.
3. SEED SOURCES SHALL BE WITHIN THE SPECIFIED RANGE OF 250 km OF THE SITE.
4. SEEDING IN THE WETLAND MITIGATION SITE SHALL BE HAND SPREAD OR BROADCAST AS SPECIFIED AT A RATE OF 33.6 KG/HA. THE SEED SHALL BE MIXED WITH A COVER CROP AS SPECIFIED AT A RATE OF 33.6 KG/HA. A UNIFORM DISTRIBUTION OF THE MIXTURE SHALL BE SOWN ON THE SITE.

WETLAND SPECIES LIST

Scientific name	Common name	KG/HA
Asclepias inarnata	Swamp Milkweed	1.12
Aster novae-angliae	New England Aster	1.12
Carex aquatilis	Long-bracted Tussock Sedge	0.56
Carex cristatella	Crested Oval Sedge	0.56
Carex scopataria	Lance-fruited Oval Sedge	0.56
Carex stipata	Common Fox Sedge	1.12
Carex vulpinoidea	Brown Fox Sedge	1.12
Elimus virginicus	Virginia Wild Rye	5.6
Juncus effusus	Common Rush	0.56
Juncus torreyi	Torrey's Rush	0.56
Leersia oryzoides	Rice Cut Grass	5.6
Lobelia siphilitica	Great Blue Lobelia	1.12
Phlox glaberrima interior	Marsh Phlox	0.56
Rudbeckia lacinata	Wild Golden Glow	1.12
Rudbeckia triloba	Brown-eyed Susan	1.12
Scirpus atrovirens	Dark Green Rush	1.12
Scirpus validus	Great Bulrush	0.56
Silphium perfoliatum	Cup Plant	1.12
Solidago riddellii	Riddell's Goldenrod	0.56
Spartina pectinata	Prairie Cord Grass	5.6
Vernonia fasciculata	Common Ironweed	1.12
Veronicastrum virginicum	Culver's Root	0.56
Zizia aurea	Golden Alexander	0.56

Seeding Rate = 33.6 KG/HA

Cover Crop

Avena sativa	Oats	11.2
Lolium multiflorum	Annual Rye	11.2
Secal cereale	Winter Rye	11.2

Seeding Rate = 33.6 KG/HA

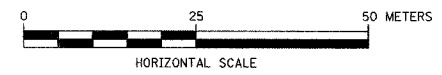

REVISIONS		
NO.	NAME	DATE

URS 1701 GOLF ROAD, SUITE 1000 TEL (847) 228-0707
ROLLING MEADOWS, IL 60008 FAX (847) 228-1115

VILLAGE OF OAK BROOK
SALT CREEK GREENWAY TRAIL
WETLAND MITIGATION PLAN

DATE: 7/20/05 DRAWN BY: MIA&VP
DESIGNED BY: MIA CHECKED BY: DDL

F. A. 7 BYE.	SECTION	COUNTY	TOTAL SHEETS	SHEET NO.
			108	32
STA.	TO STA.			
FED. ROAD DIST. NO. 1	ILLINOIS	FED. AID PROJECT		

CONTRACT No. 83714

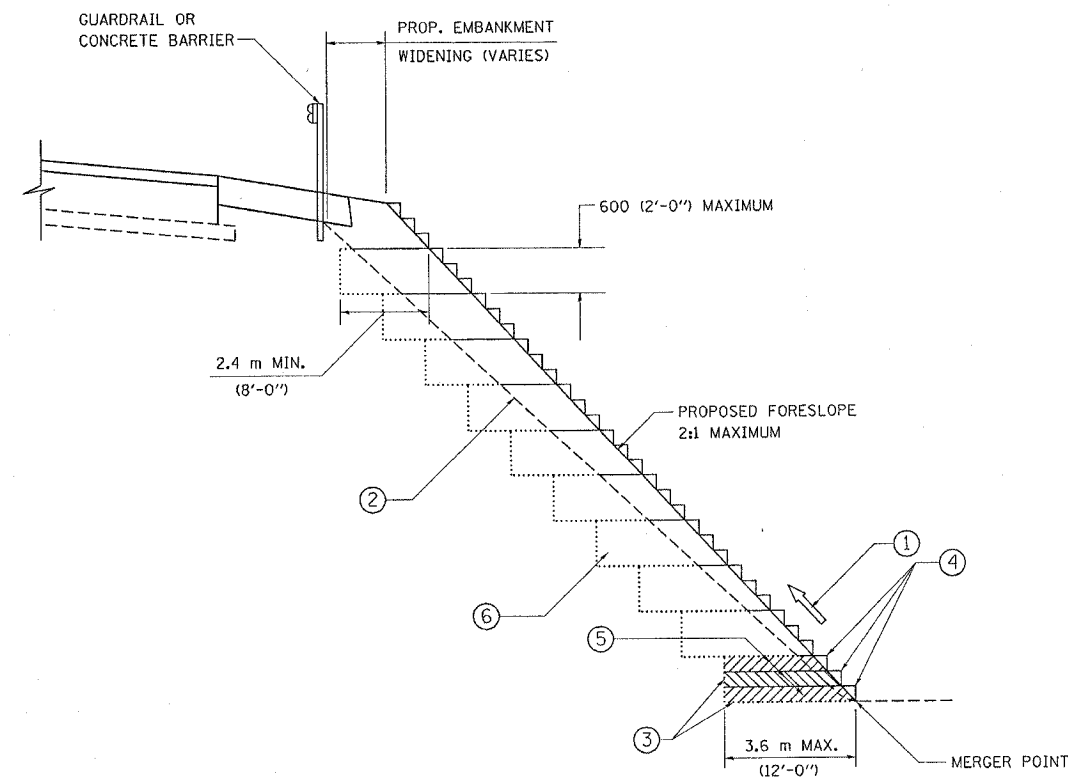

TYPICAL BENCHING DETAIL
FOR EMBANKMENT

NOTES:

- ① CONSTRUCT SUCCEEDING BENCH CUTS AND EMBANKMENT PLACEMENT AND COMPACTION FROM BOTTOM TO TOP IN STAIRSTEP FASHION.
- ② EXISTING FORESLOPE PREPARED IN ACCORDANCE WITH ARTICLE 205.04 OF THE STANDARD SPECIFICATIONS.
- ③ BENCH CUT EXISTING SLOPE TYPICAL FOR EACH STEP.
- ④ TRIM TO FINAL SLOPE.
- ⑤ EQUAL 200 (8-INCH) LIFTS OF EMBANKMENT COMPACTED IN ACCORDANCE WITH ARTICLE 205.06 OF THE STANDARD SPECIFICATIONS.
- ⑥ EXCAVATION OF BENCH CUTS WITHIN EXISTING EMBANKMENT WILL BE PAID FOR AT THE CONTRACT UNIT PRICE PER CUBIC METER OR CUBIC YARD FOR "EARTH EXCAVATION ~~SPECIAL~~". THIS PRICE WILL INCLUDE ALL LABOR AND MATERIAL NO ADDITIONAL COMPENSATION WILL BE ALLOWED.

ALL DIMENSIONS ARE IN MILLIMETERS (INCHES) UNLESS OTHERWISE SHOWN.

ILLINOIS DEPARTMENT OF TRANSPORTATION

**BENCHING DETAIL
FOR EMBANKMENT
WIDENING**

REVISIONS	
NAME	DATE

SCALE: NONE
DATE 02/28/2003

DRAWN BY: CADD
CHECKED BY: S.E.B.
BD-51

REVISION DATE:

F. A. RIE.	SECTION	COUNTY	TOTAL SHEETS	SHEET NO.
			108	33
STA.	TO STA.			
FED. ROAD DIST. NO.	ILLINOIS	FED. AID PROJECT		

CONTRACT No. 83714

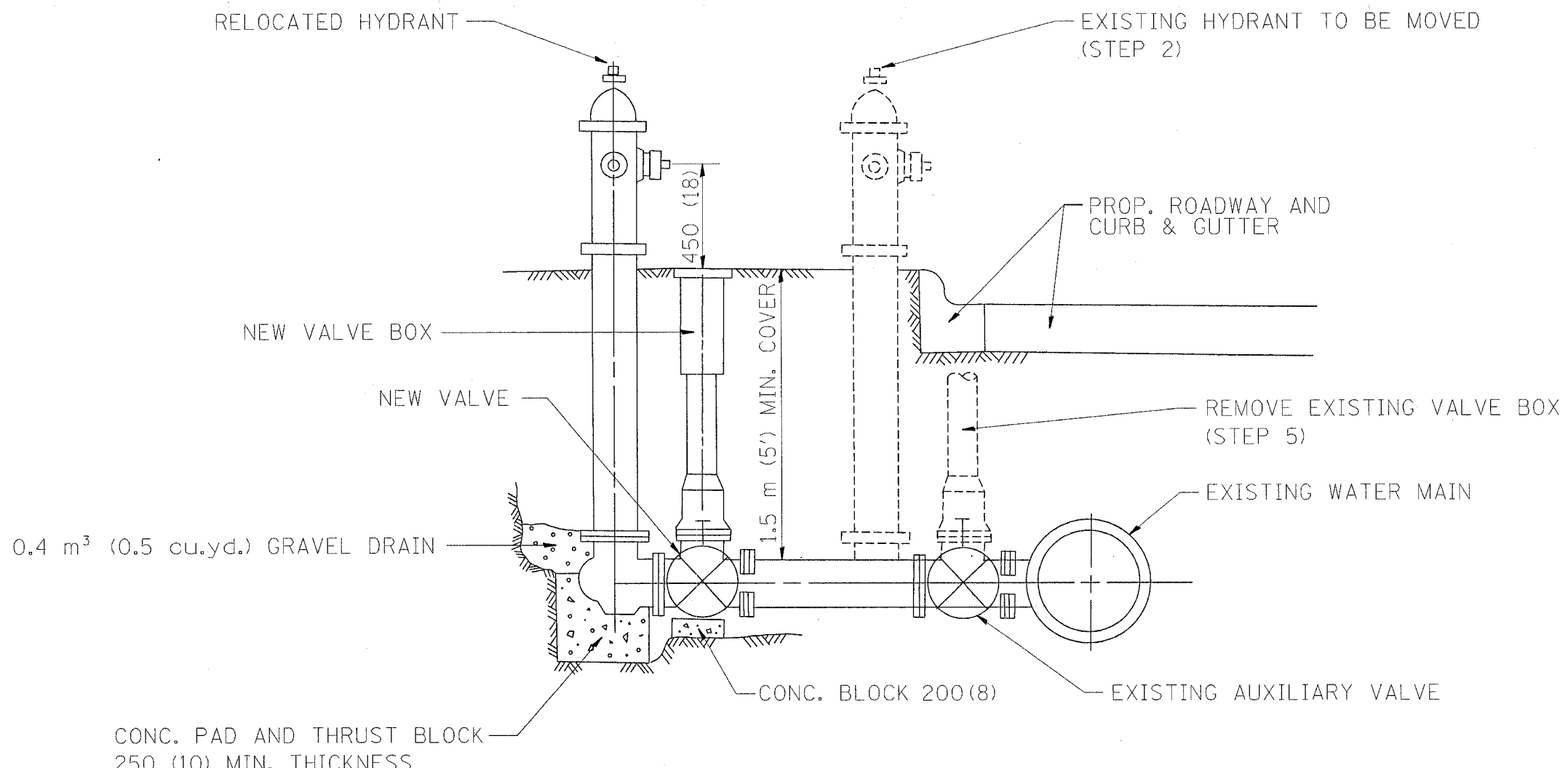

SEQUENCE OF CONSTRUCTION:

1. CLOSE EXISTING VALVE.
2. REMOVE EXISTING HYDRANT.
3. INSTALL HYDRANT EXTENSION AND NEW VALVE.
4. RELOCATE EXISTING HYDRANT.
5. OPEN EXISTING VALVE, REMOVE BOX.
6. BACKFILL.
7. FLUSH AND TEST FOR CHLORIDE RESIDUAL AND PROVIDE TEST.

ALL WORK TO BE DONE IN ACCORDANCE WITH ARTICLE 564 OF THE STANDARD SPECIFICATIONS. NEW VALVE AND BOX SHALL BE SAME MAKE AND MODEL AS EXISTING.

FIRE HYDRANT TO BE MOVED

ALL DIMENSIONS ARE IN MILLIMETERS (INCHES) UNLESS OTHERWISE SHOWN.

ILLINOIS DEPARTMENT OF TRANSPORTATION

FIRE HYDRANT TO BE MOVED

REVISIONS	
NAME	DATE
R. SHAH	09/09/94
R. SHAH	10/25/94

SCALE: NONE
DATE 02/28/2003

DRAWN BY
CHECKED BY

BD500-03 (BD-36)

REVISION DATE: 10/25/94

F.A. NO.	SECTION	COUNTY	TOTAL SHEETS	SHEET NO.
			108	34
STA.		TO STA.		
FED. ROAD DIST. NO.	ILLINOIS	FED. AID PROJECT		

CONTRACT No. 83714

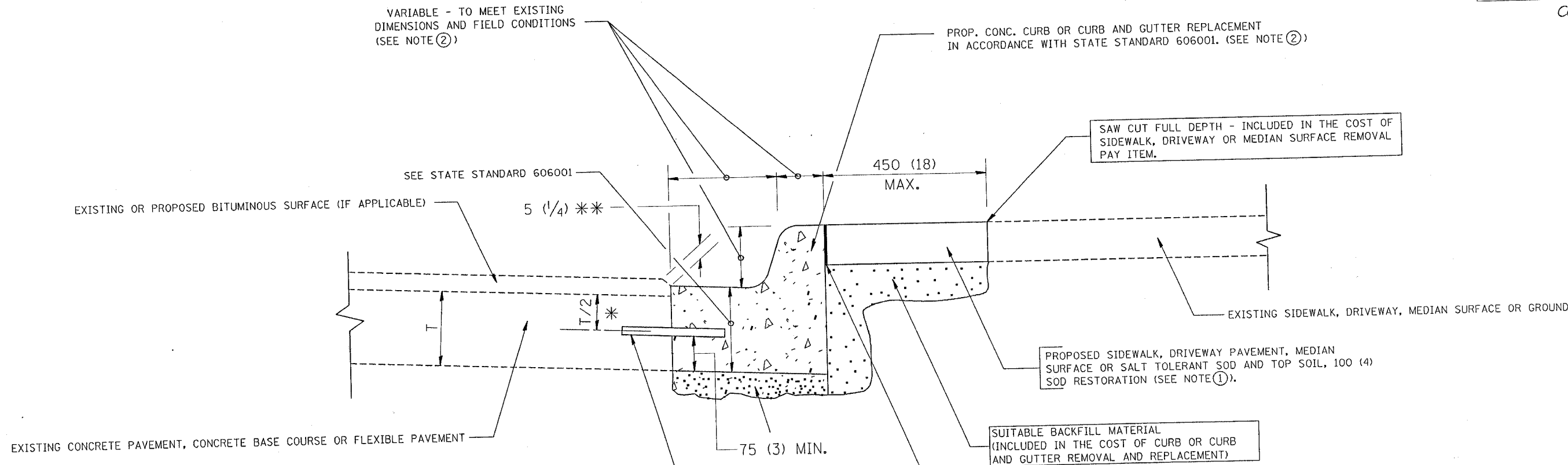

- * 75 (3) MINIMUM FROM TOP AND BOTTOM OF THE CONCRETE PAVEMENT OR BASE COURSE.
- ** IF THE FINAL SURFACE OF THE PAVEMENT IS CONCRETE, THE GUTTER IS TO BE FLUSH WITH THE PAVEMENT.

NOTE: ① SIDEWALK, DRIVEWAY PAVEMENT OR MEDIAN SURFACE SHALL BE SIMILAR TO THE MATERIAL BEING REMOVED AND WILL BE PAID FOR SEPARATELY.

SALT TOLERANT SOD AND TOP SOIL, 100 (4) RESTORATION WILL NOT BE PAID FOR SEPARATELY, BUT SHALL BE INCLUDED IN THE COST OF CURB OR CURB AND GUTTER REMOVAL AND REPLACEMENT.

② CURB OR CURB AND GUTTER REPLACEMENT SHALL MATCH THE SHAPE OF THE EXISTING CURB OR CURB AND GUTTER UNLESS OTHERWISE SPECIFIED.

③ FOR CURB OR CURB AND GUTTER REMOVAL AND REPLACEMENT ADJACENT TO FLEXIBLE PAVEMENT DELETE EPOXY COATED TIE BARS.

④ LONGITUDINAL BARS, IF ENCOUNTERED IN THE EXISTING CURB OR CURB AND GUTTER, ARE NOT TO BE REPLACED. CUTTING AND REMOVING LONGITUDINAL BARS SHALL BE INCLUDED IN THE COST OF CURB OR CURB AND GUTTER REMOVAL AND REPLACEMENT.

⑤ THE COST OF BITUMINOUS SURFACE REMOVAL IN THE EXISTING GUTTER FLAG SHALL BE INCLUDED IN THE COST OF THE CURB AND GUTTER REMOVAL AND REPLACEMENT.

⑥ THE REMOVAL AND REPLACEMENT OF THE EXISTING CURB OR CURB AND GUTTER SHALL BE DONE IN ACCORDANCE WITH THE APPLICABLE PORTIONS OF SECTION 440 AND 606 OF THE STANDARD SPECIFICATIONS.

⑦ THE LOCATIONS OF REMOVAL AND REPLACEMENT OF EXISTING CURB OR CURB AND GUTTER SHALL BE DETERMINED BY THE RESIDENT ENGINEER AT THE TIME OF CONSTRUCTION.

UNSUITABLE SUB-BASE MATERIAL TO BE REMOVED, IF DIRECTED BY THE ENGINEER, SHALL BE REPLACED WITH EITHER SUB-BASE GRANULAR MATERIAL, TYPE B OR ADDITIONAL THICKNESS OF CONCRETE.

REMOVAL AND REPLACEMENT 100 (4) OR LESS IS INCLUDED IN THE COST OF CURB OR CURB AND GUTTER REMOVAL AND REPLACEMENT.

REMOVAL AND REPLACEMENT IN EXCESS OF 100 (4) WILL BE PAID FOR IN ACCORDANCE WITH ARTICLE 109.04 OF THE STANDARD SPECIFICATIONS.

PROPOSED NO. 20 (NO. 6) EPOXY COATED TIE BARS 600 (24) LONG AT 600 (24) CENTERS WILL NOT BE PAID FOR SEPARATELY. DELETE EPOXY COATED TIE BARS IF EXISTING TIE BARS ARE USUABLE AS DETERMINED BY THE ENGINEER. (SEE NOTE 3).

BASIS OF PAYMENT:

THIS WORK WILL BE PAID FOR AT THE CONTRACT UNIT PRICE PER METER (FOOT) FOR "CURB REMOVAL AND REPLACEMENT" OR "COMBINATION CONCRETE CURB AND GUTTER REMOVAL AND REPLACEMENT".

ALL DIMENSIONS ARE IN MILLIMETERS (INCHES) UNLESS OTHERWISE SHOWN.

CURB OR CURB AND GUTTER REMOVAL AND REPLACEMENT

REVISIONS	
NAME	DATE
M. DE YONG	05/28/91
A. HOUSEH	03/11/94
R. SHAH	02/24/95
R. SHAH	03/02/95
R. SHAH	08/19/96
R. SHAH	09/12/96
R. SHAH	09/19/96
R. SHAH	10/03/96
A. ABBAS	03/21/97
M. GOMEZ	01/22/01

ILLINOIS DEPARTMENT OF TRANSPORTATION
CURB OR CURB AND GUTTER REMOVAL AND REPLACEMENT

SCALE: NONE
DATE 02/28/2003
DRAWN BY
CHECKED BY

BD600-06 (BD-24)
REVISION DATE: 12/06/99

6:03:47 02/28/2003

02/28/2003
w:\stlstd\bd24.dgn
VI-BD24

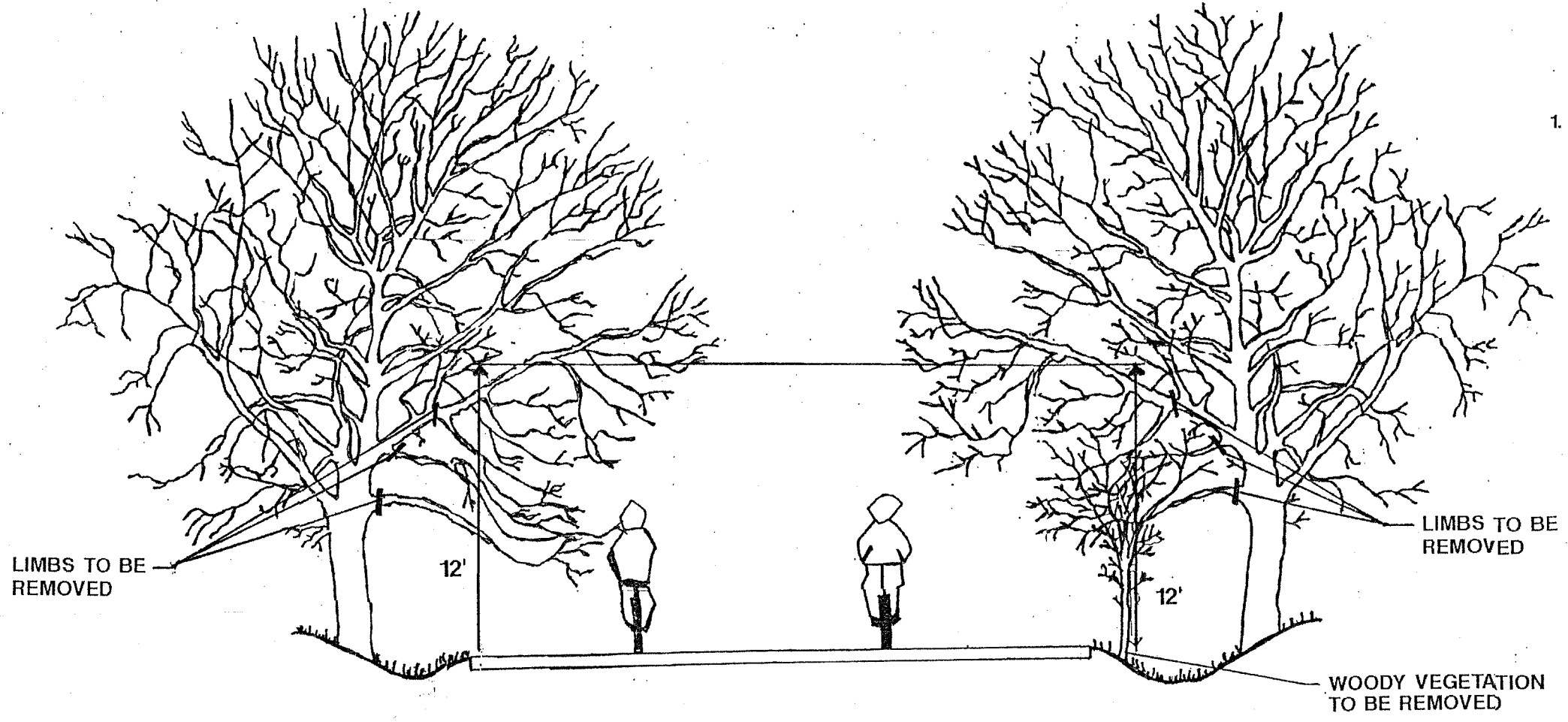

GENERAL NOTES

1. THE NATIONAL ARBORIST ASSOCIATION'S PRUNING STANDARDS FOR SHADE TREES CLASS II - STANDARD PRUNING SPECIFICATIONS SHALL BE FOLLOWED.

REVISIONS	
NAME	DATE

ILLINOIS DEPARTMENT OF TRANSPORTATION

PRUNING FOR SAFETY AND EQUIPMENT CLEARANCE

SCALE: NTS

DATE

DRAWN BY
DESIGNED BY
CHECKED BY

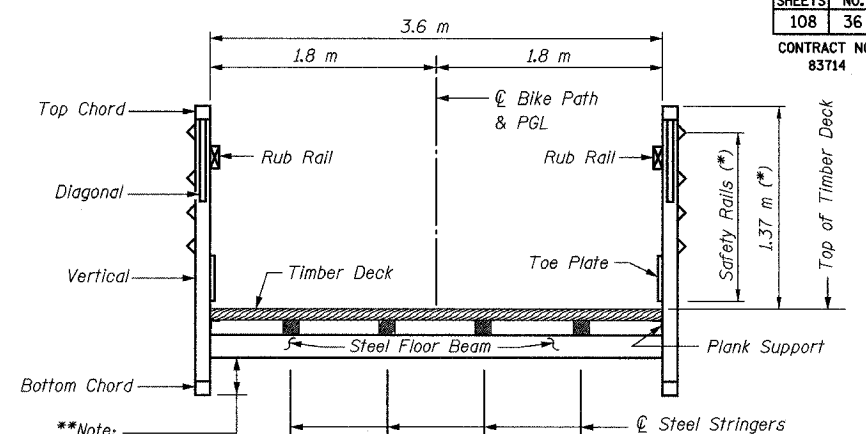
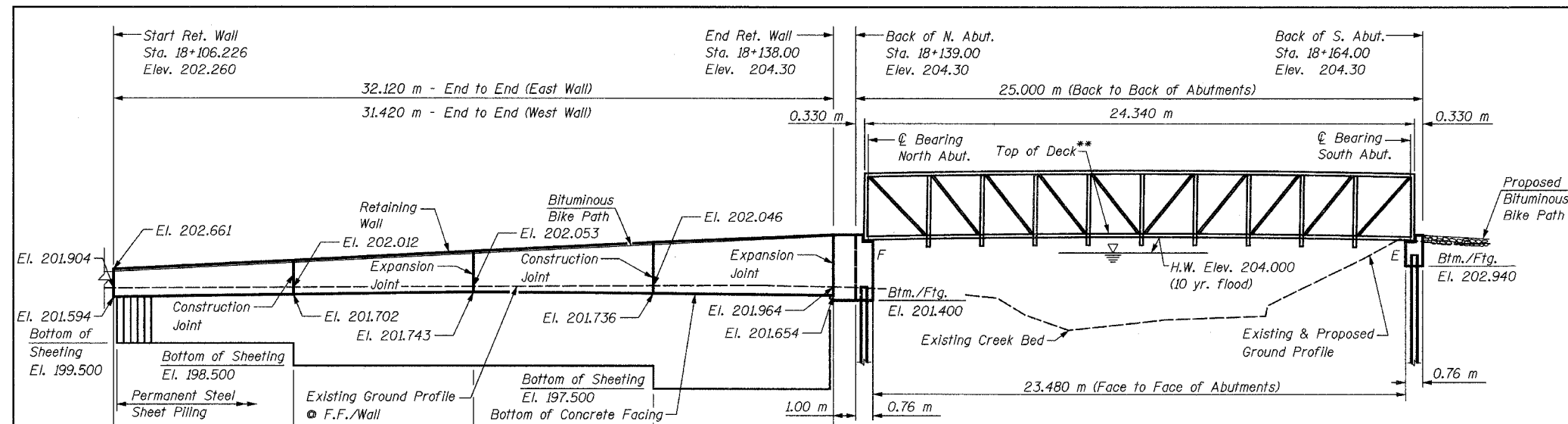

****Note:**
 Bridge Fabricator to adjust depth so that bottom chord elevation is above high water elevation.

(*) Note:
 If the top of the chord is greater than 1.37 m above the top of deck, a second rub rail shall be placed at 1.37 m above top of deck.

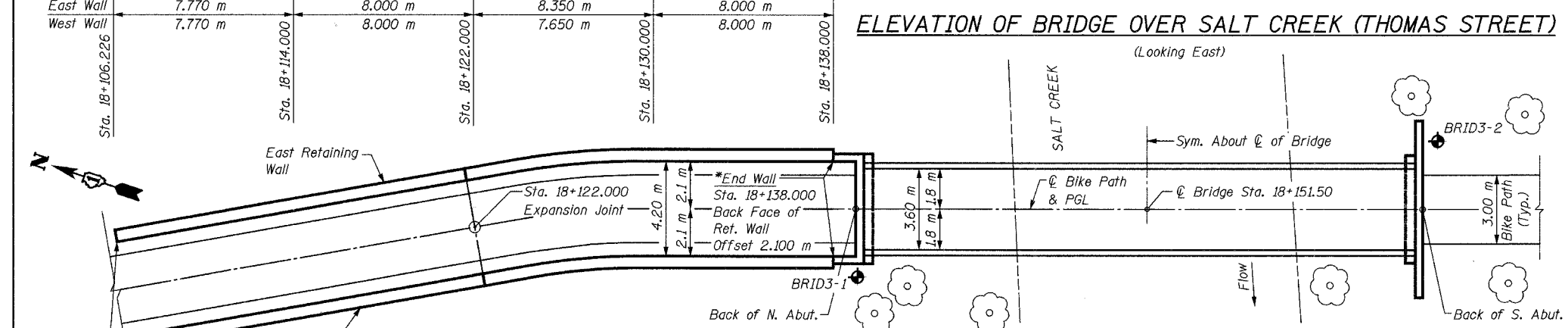

***NOTE:**
 For horizontal curve and alignment information, see Plan & Profile drawings.

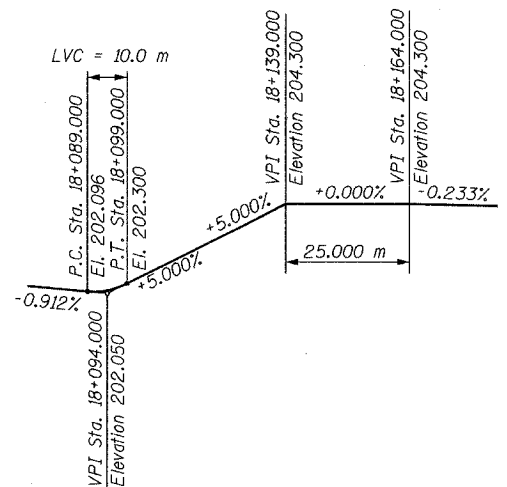

Signature: *[Signature]*
 Current Date: 7/21/05
 License Expires: 1/30/06

"I certify that to the best of my knowledge, information and belief, this bridge design is structurally adequate for the design loading shown on the plans. The design is an economical one for the style of structure and complies with the requirements of the current 'AASHTO Standard Specifications for Highway Bridges'."

LOADING

Live Loading + Impact
 4100 N/Sq. M Live Load
 (May be adjusted for influence area)
 50 kN Vehicle Load (MS-5 Truck)

Equivalent Fluid Lateral Soil Pressure
 6.3 kN/Cu. M

SEISMIC DATA

Seismic Performance Category (SPC) = A
 Bedrock Acceleration Coefficient (A) = 0.04g
 Site Coefficient (S) = 1.0

DESIGN SPECIFICATIONS

2002 AASHTO Standard Specifications for Highway Bridges, 17th Edition.
 Illinois Department of Transportation Standard Specifications for Road & Bridge Construction, adopted January 1, 2002 and Supplemental Specifications and Recurring Special Provisions adopted January 1, 2004.
 AASHTO Guide Specifications for the Design of Pedestrian Bridges, 1997 Edition.

DESIGN STRESSES

$f'_c = 24 \text{ MPa}$
 $f_y = 400 \text{ Mpa (Reinf.)}$
 $f_y = 265 \text{ Mpa (Sheet Piling)}$

CLASSIFICATION

Pedestrian/Bicycle Bridge

LEGEND

Tree to Remain
 Soil Boring

TOTAL BILL OF MATERIAL

Item	Unit	Total
Structure Excavation	Cu. M	31
Concrete Structures	Cu. M	57.0
Reinforcement Bars, Epoxy Coated	kg	3,360
Pedestrian Bridge Superstructure	Sq. M	90
Furnishing Steel Pile HP310x79	Meter	50
Driving Steel Piles	Meter	50
Test Pile Steel HP310x79	Each	1
Metal Shoes	Each	5
Permanent Steel Sheet Piling	Sq. M	306
Pipe Handrail	Meter	64

GENERAL NOTES:

- The superstructure, including all truss members, railings, toe plates, bearings, wood deck, and all attachments on superstructure, shall be designed and detailed by the Contractor.
- Reinforcement bars shall conform to the requirements of AASHTOM 31M, M 42M, or M 53M Grade 400.
- Bearing seat surfaces shall be constructed or adjusted to the designated elevations within a tolerance of 3 mm. Adjustment shall be made either by grinding the surface or by shimming the bearing. Two 3 mm adjusting shims, of the dimensions of the bottom bearing plate, shall be provided for each bearing in addition to all other plates or shims.
- The Contractor shall drive one (1) test pile in the permanent location at the South Abutment (center pile of group) as directed by the Engineer before ordering the remainder of the piles.
- The profile of the structure shall be as shown, and as specified in the Special Provisions for camber.
- The Contractor shall verify the final location of anchor bolts with the Bridge Manufacturer prior to construction and placement.
- Steel sheet piling shall conform to the requirements of Section 1006.05 of the Standard Specifications.
- If the Contractor chooses to alter the sheet piling design requirements shown on the plans for lesser design requirements, then full design submittal including plan details and sealed calculations will be required for review and acceptance by the Engineer.
- All dimensions are in millimeters (mm) except as noted.
- For Soil Boring Logs, see Special Provisions.
- Any pre-excavation carried out for placement of the sheet piling shall not extend below the bottom of concrete facing.

REVISIONS		NAME	DATE
NO.	DESCRIPTION		

URS 1701 GOLF ROAD, SUITE 1000 TEL (847) 228-0707
 ROLLING MEADOWS, IL 60008 FAX (847) 228-1115

VILLAGE OF OAKBROOK
**SALT CREEK GREENWAY TRAIL
 BRIDGE & RET. WALL, STA. 18+151.5**
 GENERAL PLAN AND ELEVATION

DATE: 06/30/05
 DESIGNED BY: MDS
 DRAWN BY: MDS
 CHECKED BY: GAT

BILL OF MATERIAL

Bar	No.	Size	Length	Shape
h107(E)	18	#15	7.67 m	—
h108(E)	42	#15	8.64 m	—
h109(E)	12	#15	8.25 m	—
h110(E)	12	#15	7.45 m	—
u10(E)	229	#15	1.45 m	□
v103(E)	54	#15	1.25 m	—
v104(E)	54	#15	1.61 m	—
v105(E)	54	#15	2.01 m	—
v106(E)	56	#15	2.55 m	—
Concrete Structures		Cu. M	39.7	
Reinforcement Bars, Epoxy Coated		kg	2,250	
Structure Excavation		Cu. M	12.0	
Permanent Steel Sheet Piling		Sq. M	306	
Pipe Handrail		Meter	64	

***NOTE:**

For horizontal curve and alignment information, see Plan & Profile drawings.

NOTES:

- Cut h(E) and v(E) bars as necessary in field to fit.
- Minimum lap for #15 bar - 640 mm
- All exposed edges of concrete shall have a 20 mm chamfer unless shown otherwise.
- For minimum effective section modulus properties for sheet piling sections, refer to special provision for Permanent Steel Sheet Piling.
- Work this sheet with Sheet S3.
- Bars designated (E) shall be epoxy coated.
- All dimensions are in millimeters (mm) except as noted.
- For Typical Section thru Wall, see Sheet S3.

SHEET S2 of S33

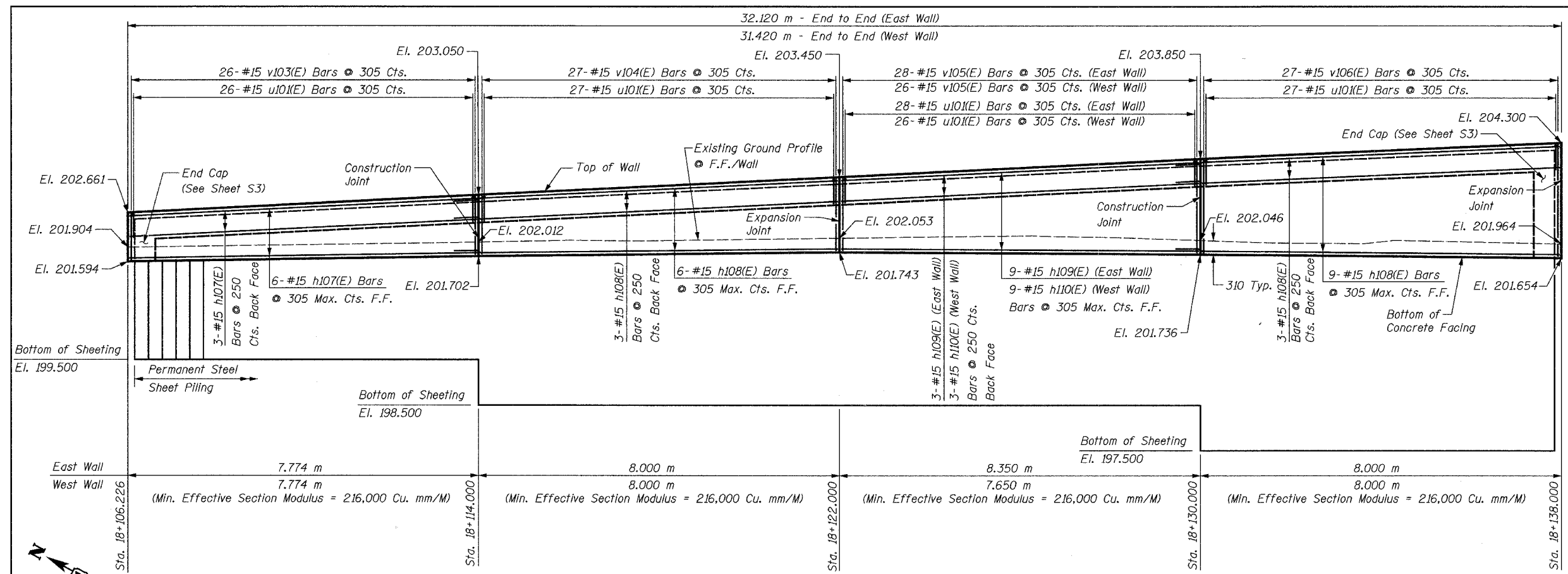

ELEVATION - WEST RETAINING WALL

(Sta. 18+106.226 to Sta. 18+138)
 (East Wall similar, except as noted)

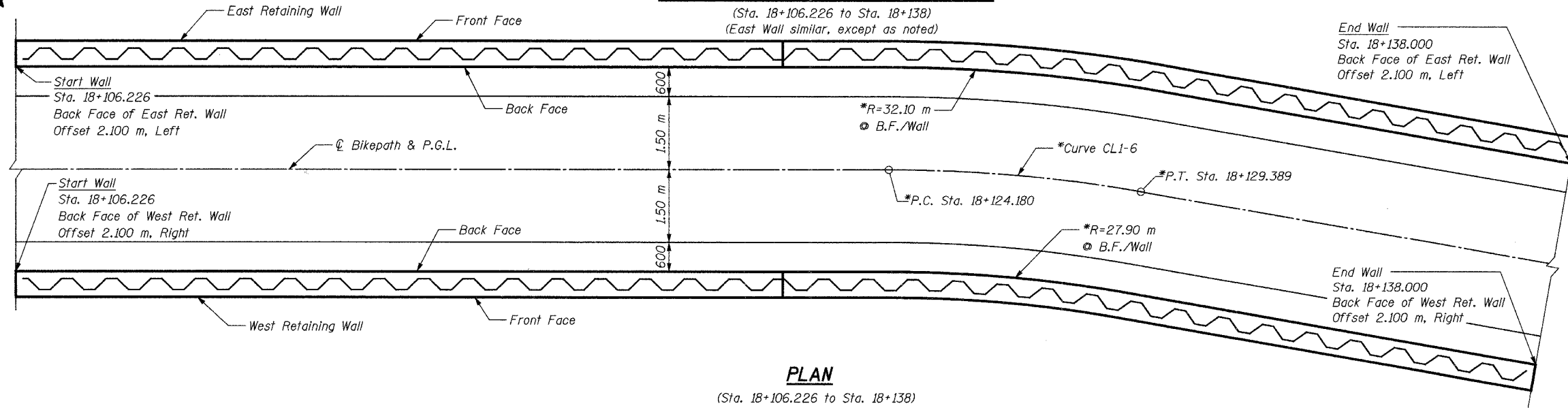

PLAN

(Sta. 18+106.226 to Sta. 18+138)
 (Reinforcement Omitted for Clarity)

Bar	A	B	R
h109(E)	2.13 m	6.12 m	32.6 m
h110(E)	2.13 m	5.32 m	27.4 m



BARS h109(E) & h110(E)

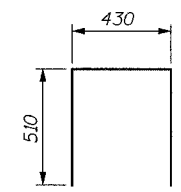

BAR u10(E)

REVISIONS		NAME	DATE
NO.	DESCRIPTION		

URS 1701 GOLF ROAD, SUITE 1000 TEL (847) 228-0707
 ROLLING MEADOWS, IL 60008 FAX (847) 228-1115

VILLAGE OF OAKBROOK
 SALT CREEK GREENWAY TRAIL
 RET. WALL, STA. 18+106.226
 PLAN & ELEVATION

DATE: 06/30/05
 DESIGNED BY: MDS
 DRAWN BY: MDS
 CHECKED BY: GAT

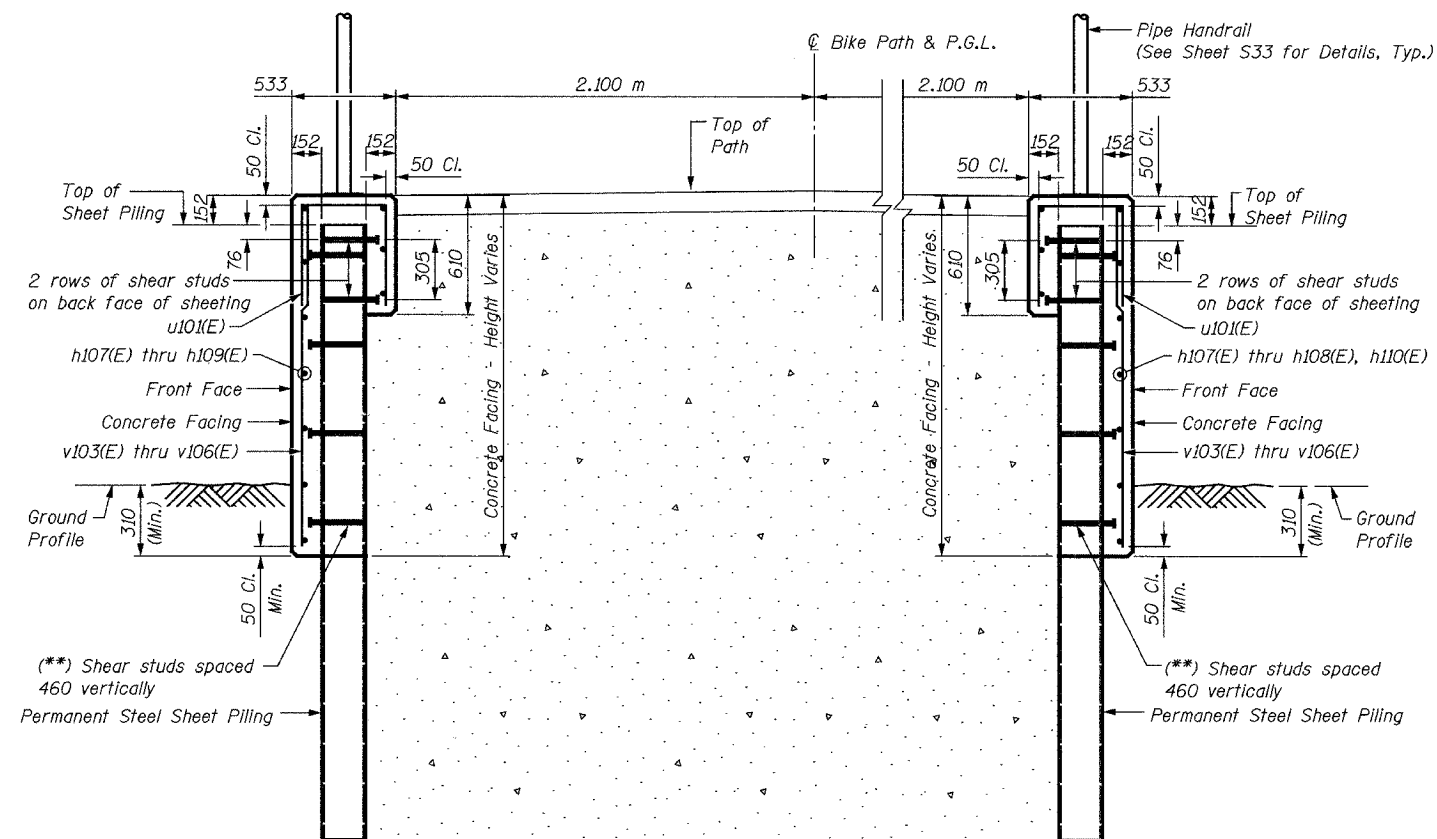

TYPICAL SECTION THRU WALL
(Sta. 18+106.226 to Sta. 18+138)

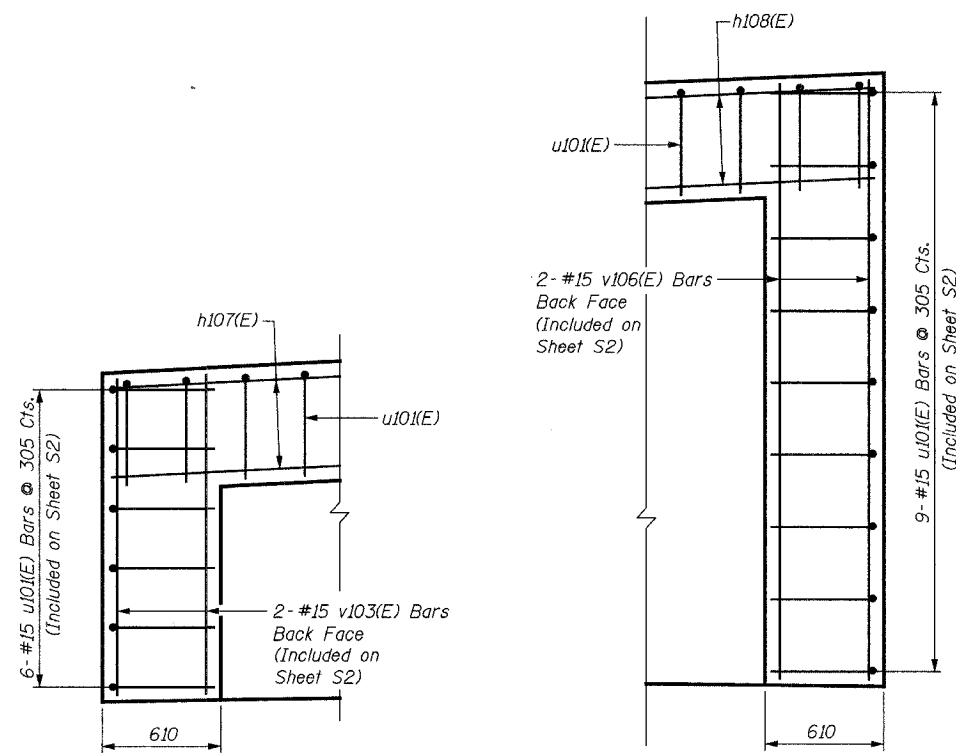

NORTH END

SOUTH END

END CAP WALL DETAILS
(East Wall, West Wall Similar)

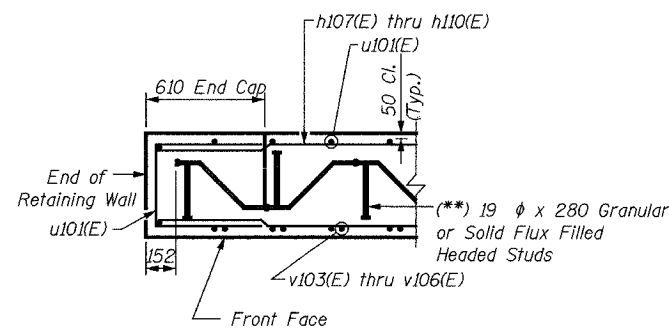

SECTION THRU CAP

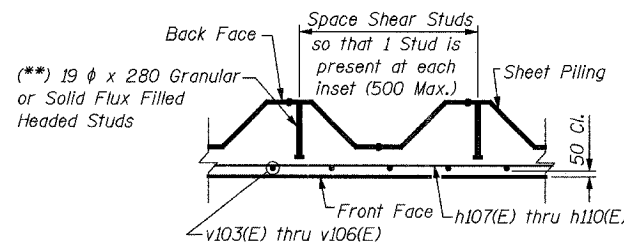

TYPICAL SECTION THRU WALL

() NOTE:**

Shear Studs shall be 19 dia. x 208 Granular or Solid Flux Filled Studs conforming to 505.08 (m) of the Standard Specifications automatically end welded in the field to Sheet Piling. The cost of the studs is included in the cost of PERMANENT STEEL SHEET PILING.

NOTES:

See Sheet S2 for notes.

SHEET S3 of S33

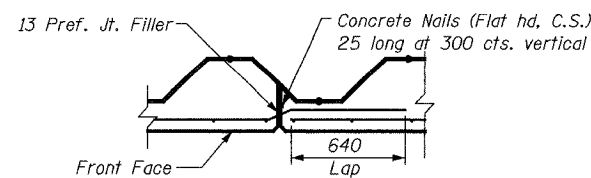

CONSTRUCTION JOINT DETAILS

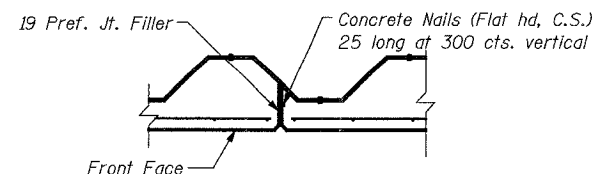

EXPANSION JOINT DETAILS

REVISIONS		URS	1701 GOLF ROAD, SUITE 1000 ROLLING MEADOWS, IL 60008	TEL (847) 228-0707 FAX (847) 228-1115
NAME	DATE			
		VILLAGE OF OAKBROOK SALT CREEK GREENWAY TRAIL RET. WALL STA. 18+106 TO 18+138 DETAILS		

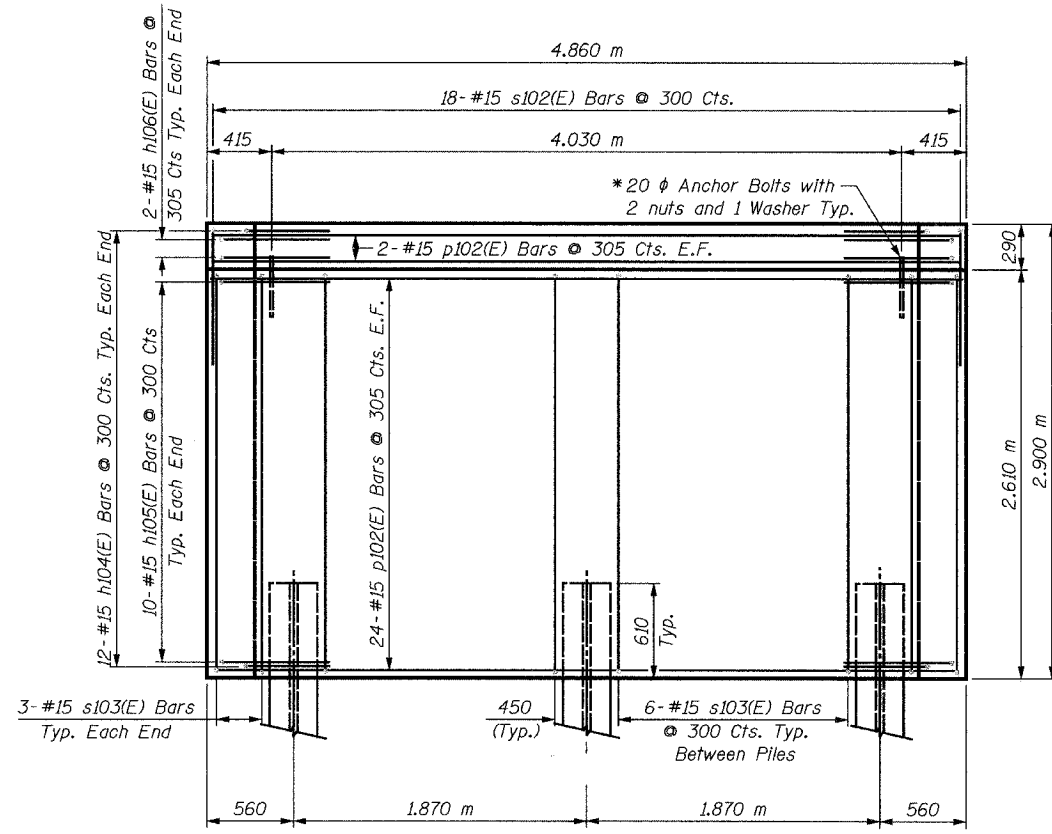

ELEVATION

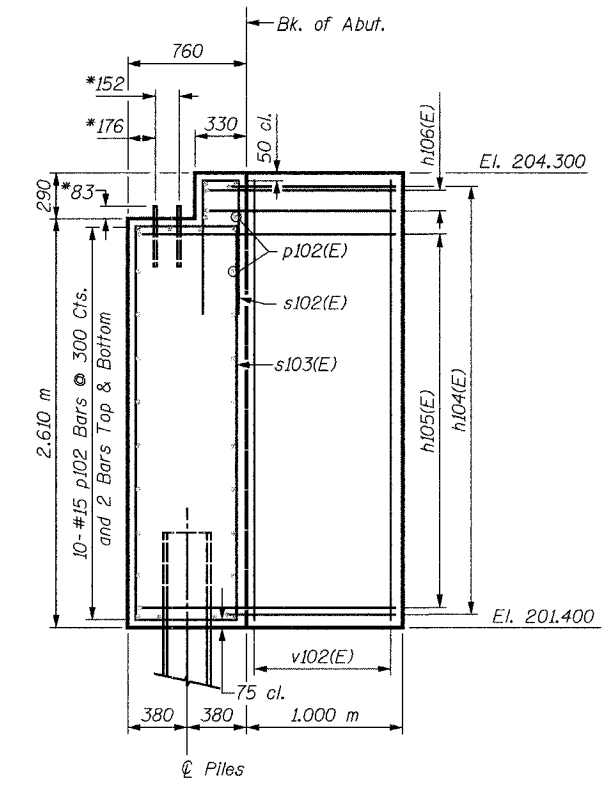

SIDE VIEW

PILE DATA:

Type: HP310x79
 Capacity: Driven to Refusal
 Est. Length: 10 m
 No. Required: 3

*Anchor bolt size and locations shall be checked against the Bridge Fabricator's requirements prior to setting them.

BILL OF MATERIAL

Bar	No.	Size	Length	Shape
h104(E)	24	#15	1.90 m	┌───┐
h105(E)	20	#15	2.56 m	┌───┐
h106(E)	4	#15	2.13 m	┌───┐
p102(E)	28	#15	4.76 m	───
s102(E)	18	#15	2.49 m	┌───┐
s103(E)	18	#15	6.56 m	┌───┐
v102(E)	20	#15	2.80 m	───
Concrete Structures			Cu. M	12.0
Reinforcement Bars, Epoxy Coated			kg	690
Furnishing Steel Piles				
HP310x79			Meter	30
Driving Steel Piles			Meter	30
Metal Shoes			Each	3
Structure Excavation			Cu. M	7

LEGEND

E.F. = Each Face

MIN. BAR LAP

#15 = 890

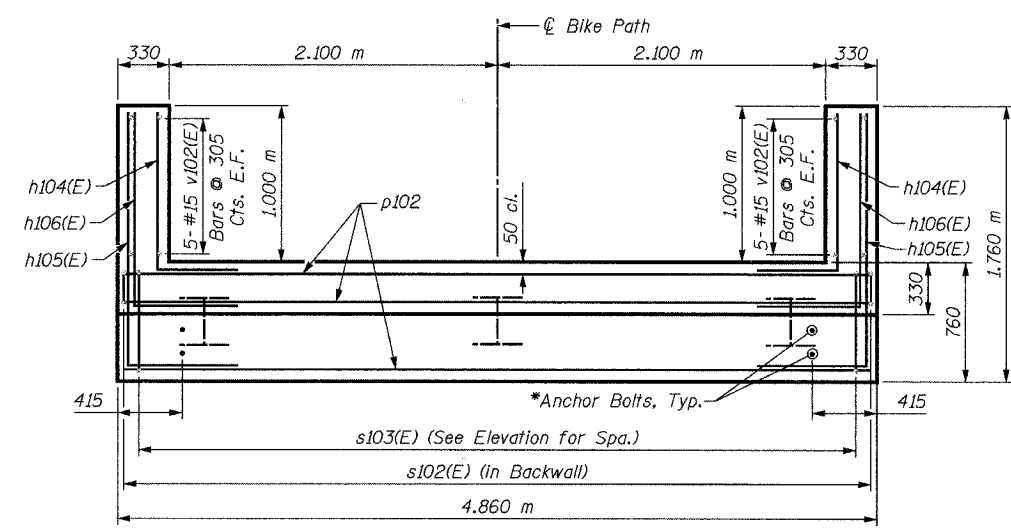

PLAN

Bar	A	B
h104(E)	0.900 m	1.000 m
h105(E)	0.900 m	1.660 m
h106(E)	0.900 m	1.230 m

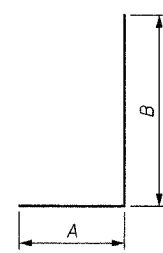

BAR h104(E) TO h106(E)

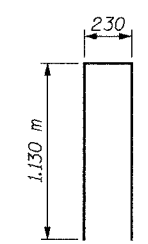

BAR s102(E)

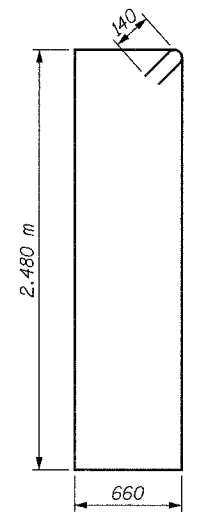

BAR s103(E)

NOTES:

- Space reinforcement in cap to miss anchor bolts.
- All edges shall have standard 20 mm chamfers except as noted.
- For Anchor Bolt Details, see Sheet S32.
- There shall be no splicing of longitudinal bars. Bars shall be ordered full length.
- Bars designated (E) shall be epoxy coated.

SHEET S4 of S33

REVISIONS		1701 GOLF ROAD, SUITE 1000 ROLLING MEADOWS, IL 60008 TEL (847) 228-0707 FAX (847) 228-1115
NAME	DATE	
		VILLAGE OF OAKBROOK SALT CREEK GREENWAY TRAIL PEDESTRIAN BRIDGE, STA. 18+151.5 NORTH ABUTMENT DETAILS
DATE: 06/30/05 DESIGNED BY: MDS		DRAWN BY: MDS CHECKED BY: GAT

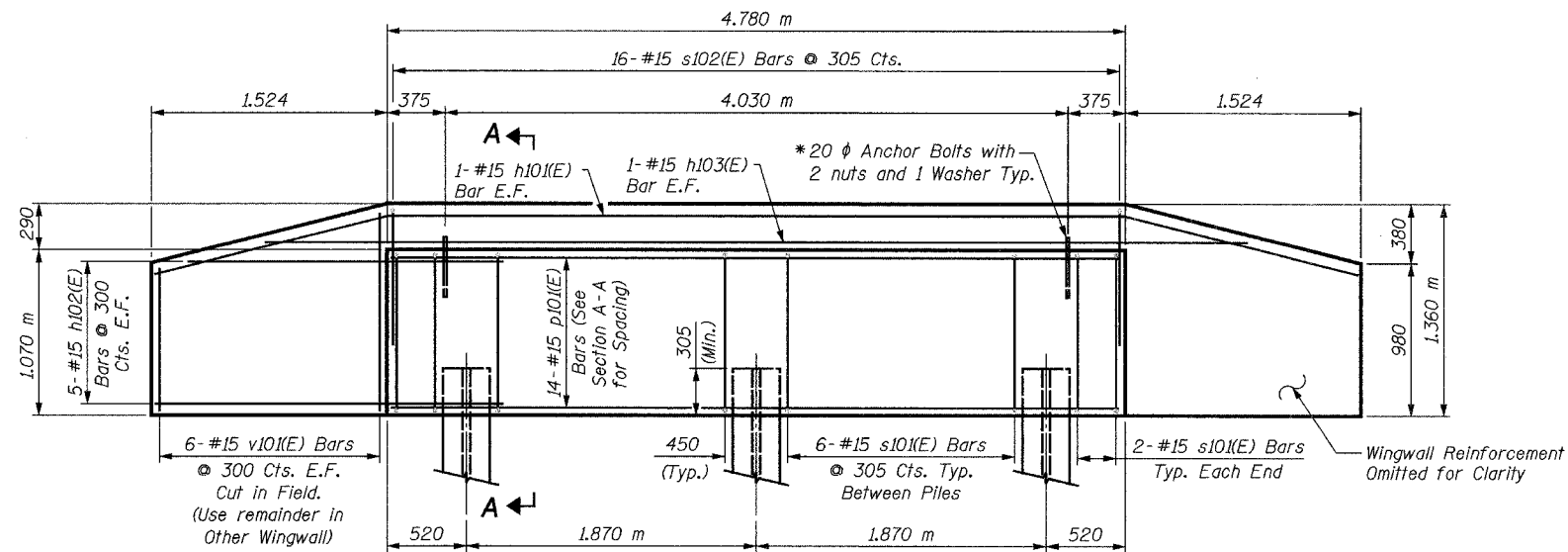

ABUTMENT ELEVATION

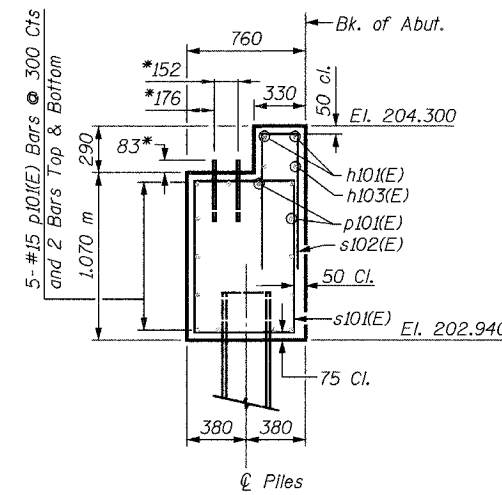

SECTION A-A

* Anchor bolt size and locations shall be checked against the bridge fabricator's requirements prior to setting them.

BILL OF MATERIAL

Bar	No.	Size	Length	Shape
h101(E)	2	#15	7.81 m	
h102(E)	20	#15	2.42 m	
h103(E)	2	#15	6.35 m	
p101(E)	14	#15	4.68 m	
s101(E)	16	#15	3.48 m	
s102(E)	16	#15	2.49 m	
v101(E)	12	#15	2.14 m	
Concrete Structures			Cu. M	5.5
Reinforcement Bars, Epoxy Coated			kg	420
Furnishing Steel Piles HP310x79			Meter	20
Driving Steel Piles			Meter	20
Test Pile Steel HP310x79			Each	1
Metal Shoes			Each	2
Structure Excavation			Cu. M	13

LEGEND

E.F. = Each Face

MIN. BAR LAP

#15 = 890

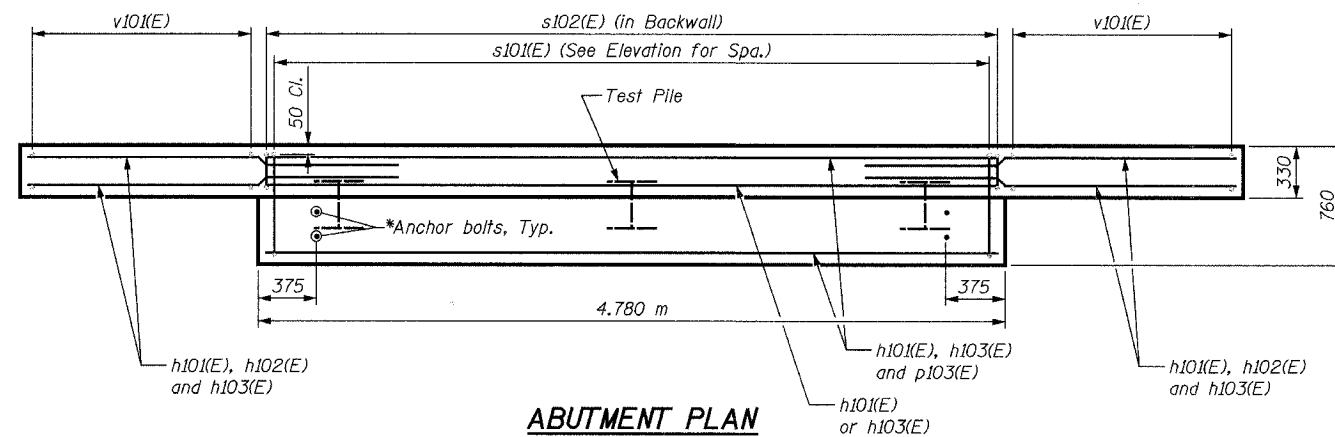

ABUTMENT PLAN

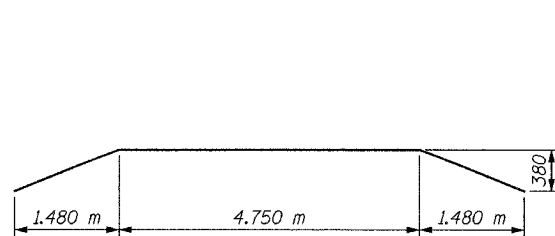

BAR h101(E)

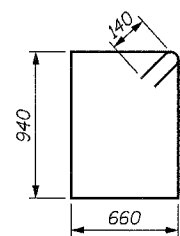

BAR s101(E)

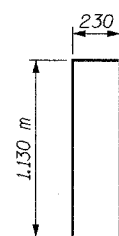

BAR s102(E)

PILE DATA:

Type: HP310x79
Capacity: Driven to Refusal
Est. Length: 10 m
No. Required: 2 + 1 Test Pile

(Test pile shall be a permanent pile driven at the South Abutment)

NOTES:

- Space reinforcement in cap to miss anchor bolts.
- All edges shall have standard 20 mm chamfers except as noted.
- For Anchor Bolt Details, see Sheet S32.
- There shall be no splicing of longitudinal bars. Bars shall be ordered full length.
- Bars designated (E) shall be epoxy coated.

SHEET S5 of S33

REVISIONS		NAME	DATE	1701 GOLF ROAD, SUITE 1000 ROLLING MEADOWS, IL 60008 TEL (847) 228-1070 FAX (847) 228-1115
NO.	DESCRIPTION			
				VILLAGE OF OAKBROOK SALT CREEK GREENWAY TRAIL PEDESTRIAN BRIDGE, STA. 18+151.5 SOUTH ABUTMENT DETAILS
DATE: 06/30/05		DESIGNED BY: MDS		DRAWN BY: MDS CHECKED BY: GAT

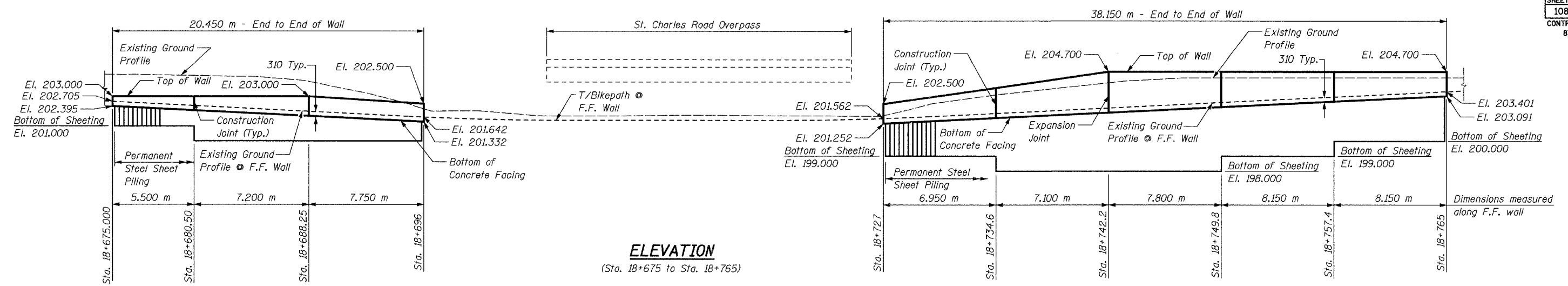

ELEVATION
 (Sta. 18+675 to Sta. 18+765)

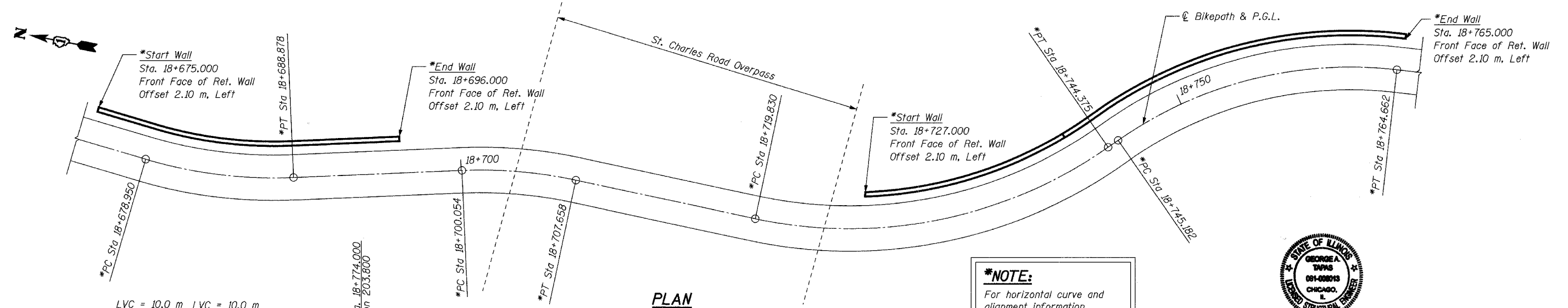

PLAN
 (Sta. 18+675 to Sta. 18+765)
 (Reinforcement Omitted for Clarity)

***NOTE:**
 For horizontal curve and alignment information, see Plan & Profile drawings



Signature: [Signature]
 Current Date: 7/21/05
 License Expires: 11/30/06

"I certify that to the best of my knowledge, information and belief, this retaining wall design is structurally adequate for the design loading shown on the plans. The design is an economical one for the style of structure and complies with the requirements of the current 'AASHTO Standard Specifications for Highway Bridges'."

SHEET S6 of S33

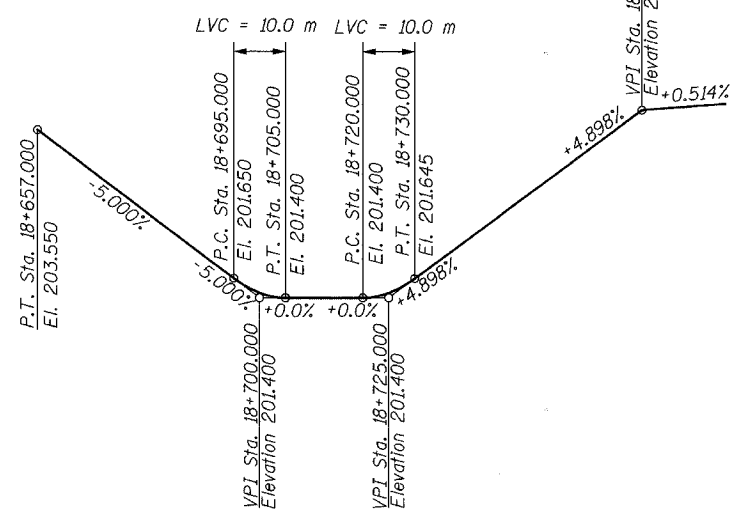

PROFILE GRADE

DESIGN LOADING
 Equivalent Fluid Lateral Soil Pressure
 6.3 kN/Cu. M

DESIGN STRESSES
 f'c = 24 MPa
 fy = 400 MPa (Reinf.)
 fy = 270 MPa (Sheet Piling)

DESIGN SPECIFICATIONS

2002 AASHTO Standard Specifications for Highway Bridges, 17th Edition.
 Illinois Department of Transportation Standard Specifications for Road & Bridge Construction, adopted January 1, 2002 and Supplemental Specifications and Recurring Special adopted January 1, 2004.

TOTAL BILL OF MATERIAL

Item	Unit	Quantity
Concrete Structures	Cu. M	36.2
Reinforcement Bars, Epoxy Coated	kg	2,200
Structure Excavation	Cu. M	32.9
Permanent Steel Sheet Piling	Sq. M	255
Pipe Handrail	Meter	59

GENERAL NOTES:

- Reinforcement bars shall conform to the requirements of AASHTO M 31M, M 42M or M 53M Grade 400.
- Plan dimensions and details relative to existing structure have been taken from existing plans and are subject to nominal construction variations. It shall be the Contractor's responsibility to verify such dimensions and details in the field and make necessary approved adjustments prior to construction or ordering of materials. Such variations shall not be cause for additional compensation for a change in the scope of work; however, the Contractor will be paid for the quantity actually furnished at the unit price bid for the work.
- Steel sheet piling shall conform to the requirements of Section 1006.05 of the Standard Specifications.
- If the Contractor chooses to alter the sheet piling design requirements shown on the plans for lesser design requirements, then full design submittal including plan details and sealed calculations will be required for review and acceptance by the Engineer.
- All dimensions are in millimeters (mm) except as noted.
- For Soil Boring logs, see Special Provisions.
- Any pre-excavation carried out for placement of the sheet piling shall not extend below the bottom of concrete facing elevation.

REVISIONS		NAME	DATE
NO.	DESCRIPTION		

URS 1701 GOLF ROAD, SUITE 1000 TEL (847) 228-0707
 ROLLING MEADOWS, IL 60008 FAX (847) 228-1115

VILLAGE OF OAKBROOK
SALT CREEK GREENWAY TRAIL
RET. WALL, STA 18+665 & 18+727
GENERAL PLAN & ELEVATION

DATE: 06/30/05
 DESIGNED BY: MDS
 DRAWN BY: MDS
 CHECKED BY: GAT

BILL OF MATERIAL

Bar	No.	Size	Length	Shape
h205(E)	8	#15	5.40 m	—
h206(E)	8	#15	8.40 m	—
h207(E)	8	#15	7.80 m	—
u203(E)	79	#15	1.45 m	⊏
v203(E)	21	#15	0.79 m	—
v204(E)	52	#15	1.18 m	—
Concrete Structures			Cu. M	9.0
Reinforcement Bars, Epoxy Coated			kg	580
Structure Excavation			Cu. M	11.5
Permanent Steel Sheet Piling			Sq. M	51
Pipe Handrail			Meter	21

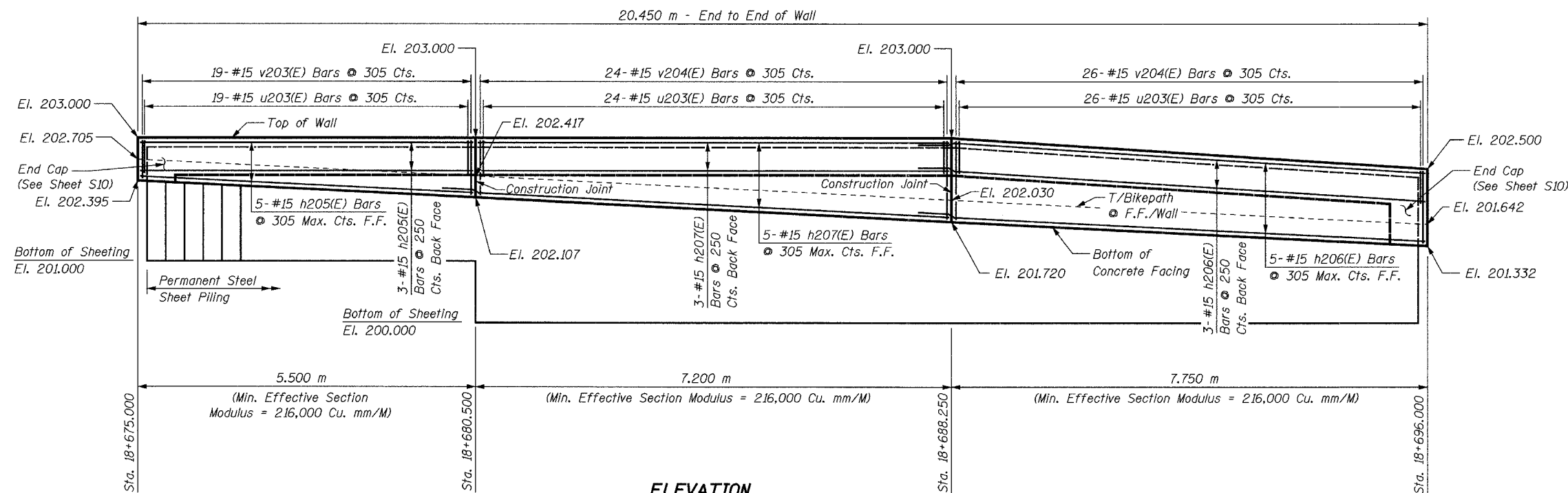

ELEVATION

(Sta. 16+675 to Sta. 16+696)

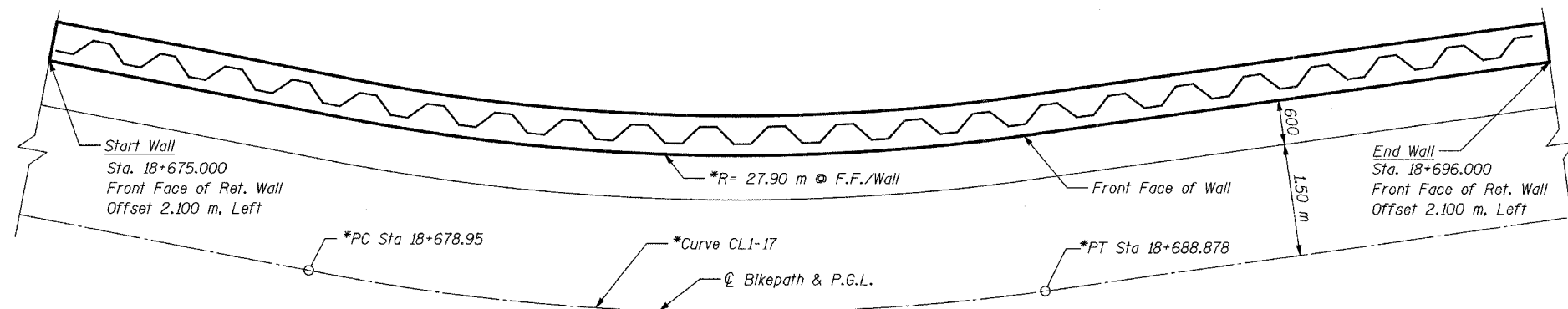
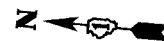
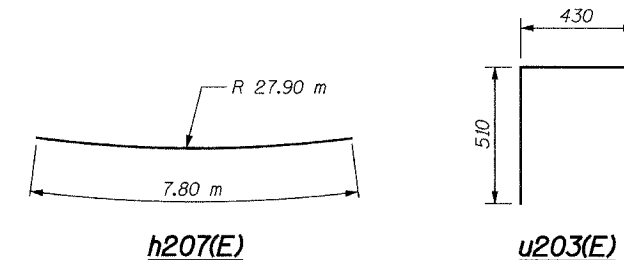

PLAN

(Sta. 16+675 to Sta. 16+696)
(Reinforcement Omitted for Clarity)

*NOTE:

For horizontal curve and alignment information, see Plan & Profile drawings.

NOTES:

Cut h(E) and v(E) bars as necessary in field to fit.

Minimum lap for #15 bar - 640 mm

All exposed edges of concrete shall have a 20 mm chamfer unless shown otherwise.

For minimum effective section modulus properties for sheet piling sections, refer to special provision for Permanent Steel Sheet Piling.

Work this sheet with Sheet S6 thru S10.

Bars designated (E) shall be epoxy coated.

All dimensions are in millimeters (mm) except as noted.

For Typical Section thru Wall, see Sheet S10.

SHEET S7 of S33

REVISIONS		NAME	DATE	URS 1701 GOLF ROAD, SUITE 1000 ROLLING MEADOWS, IL 60008 TEL (847) 228-0707 FAX (847) 228-1115
NO.	DESCRIPTION			
				VILLAGE OF OAKBROOK SALT CREEK GREENWAY TRAIL RET. WALL STA. 18+665 TO 18+696 PLAN & ELEVATION
DATE: 06/30/05		DESIGNED BY: MDS		DRAWN BY: MDS CHECKED BY: GAT

BILL OF MATERIAL

Bar	No.	Size	Length	Shape
h208(E)	13	#15	6.85 m	
h209(E)	13	#15	7.74 m	
u203(E)	59	#15	1.45 m	
v207(E)	24	#15	1.89 m	
v208(E)	25	#15	2.62 m	
Concrete Structures			Cu. M	9.6
Reinforcement Bars, Epoxy Coated			kg	610
Structure Excavation			Cu. M	7.9
Permanent Steel				
Sheet Piling			Sq. M	70
Pipe Handrail			Meter	14

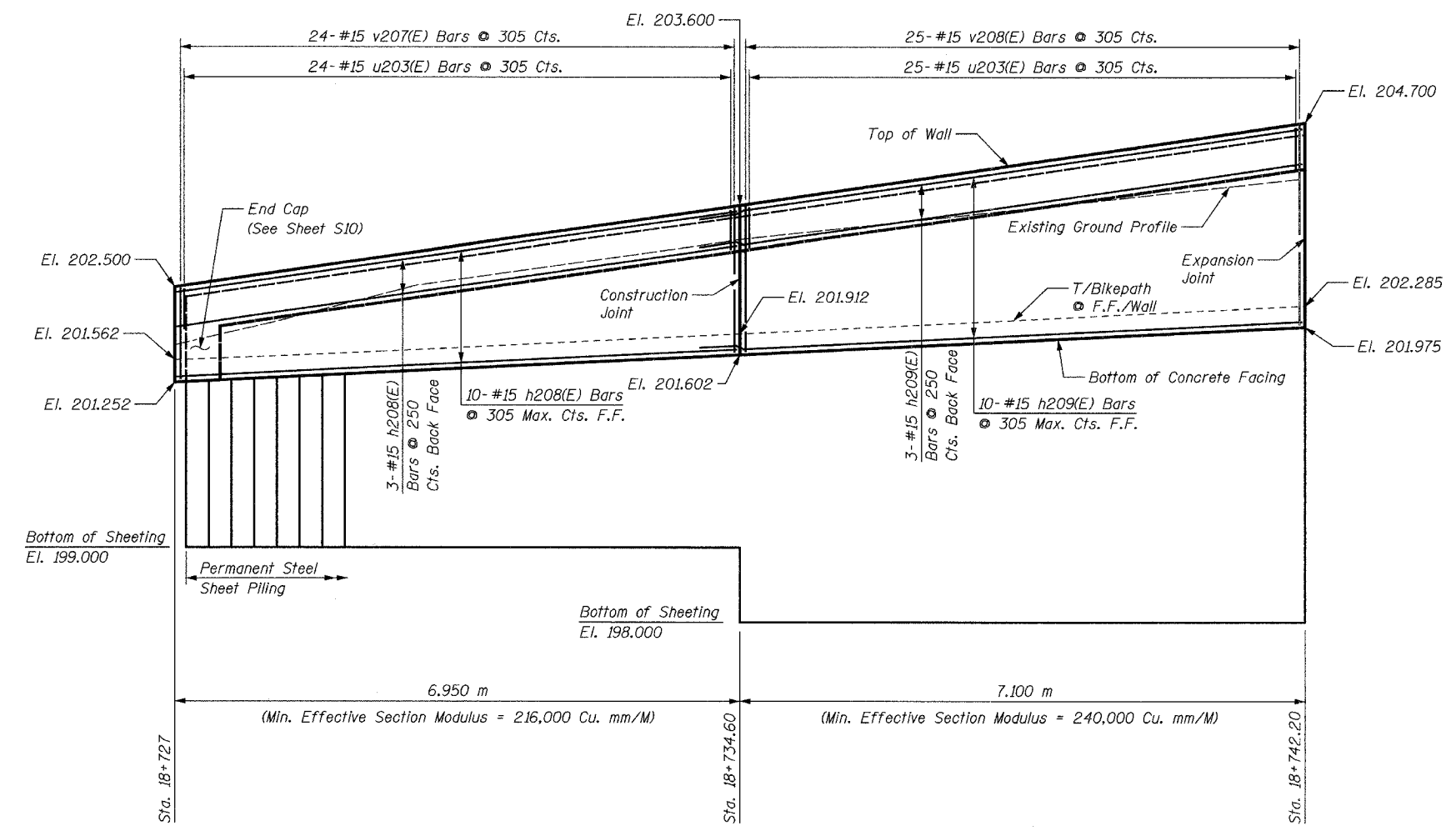

ELEVATION - RETAINING WALL

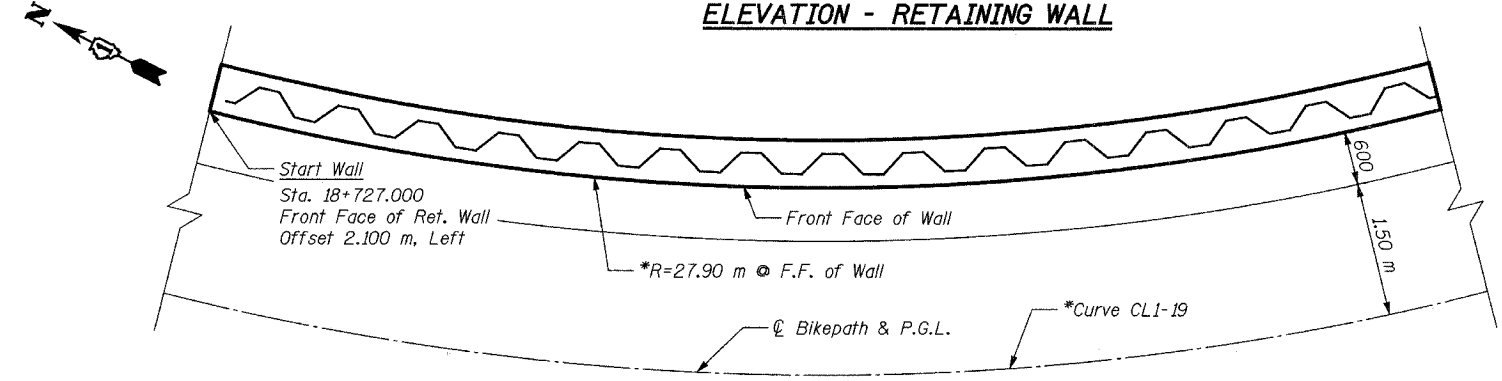

PLAN - RETAINING WALL

***NOTE:**
For horizontal curve and alignment information, see Plan & Profile drawings.

Bar	Radius	Length
h208(E)	27.90 m	6.85 m
h209(E)	27.90 m	7.74 m

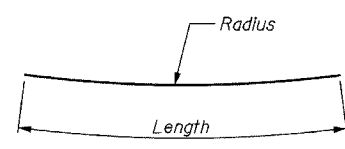

h208(E) & h209(E)

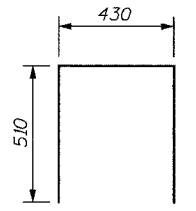

u203(E)

NOTES:
For Notes see Sheet S7.

SHEET S8 of S33

REVISIONS		NAME	DATE	URS 1701 GOLF ROAD, SUITE 1000 TEL (847) 228-0707 ROLLING MEADOWS, IL 60008 FAX (847) 228-1115
NO.	DESCRIPTION			
				VILLAGE OF OAKBROOK SALT CREEK GREENWAY TRAIL RET. WALL STA. 18+727 TO 18+742.2 PLAN & ELEVATION
DATE: 06/30/05		DRAWN BY: MDS		DESIGNED BY: MDS CHECKED BY: GAT

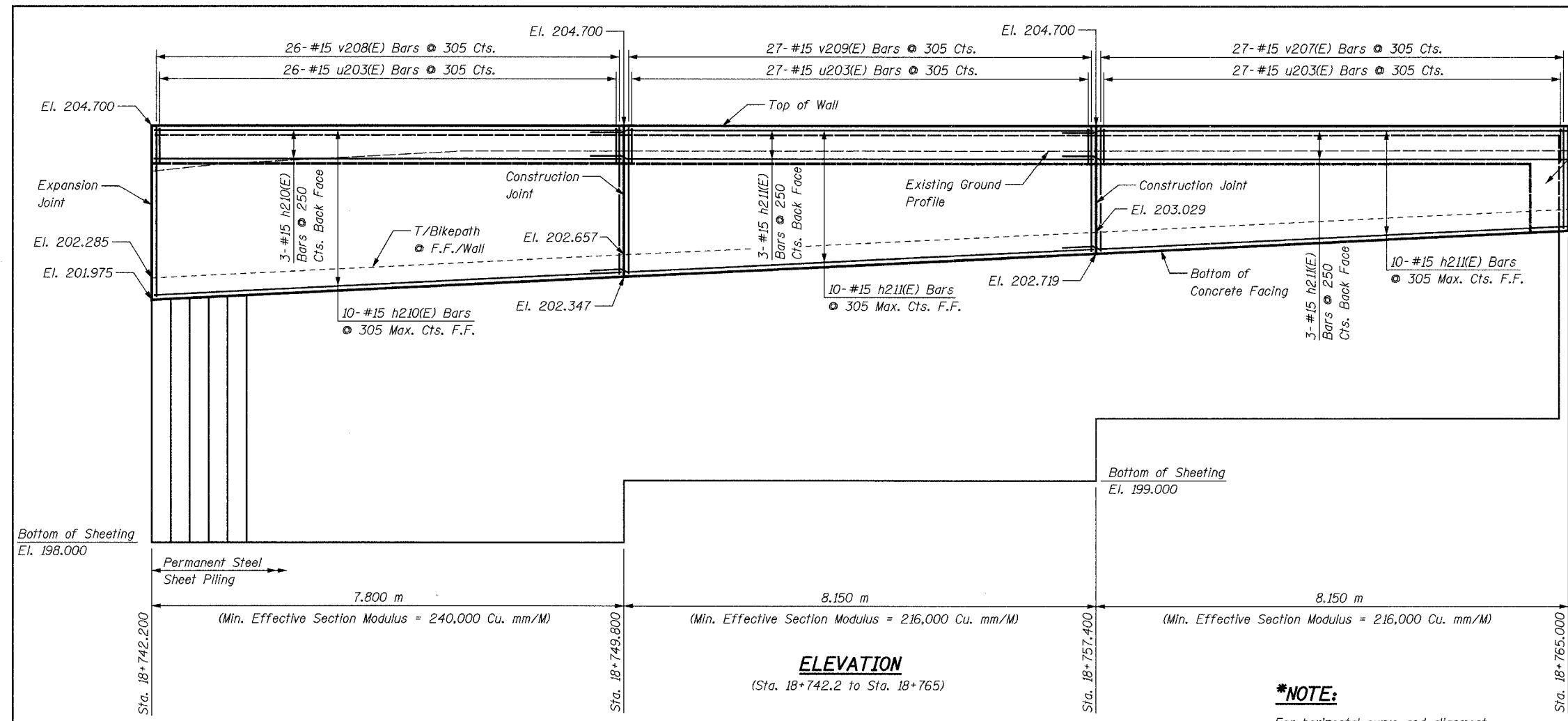

ELEVATION
(Sta. 18+742.2 to Sta. 18+765)

***NOTE:**
For horizontal curve and alignment information, see Plan & Profile drawings.

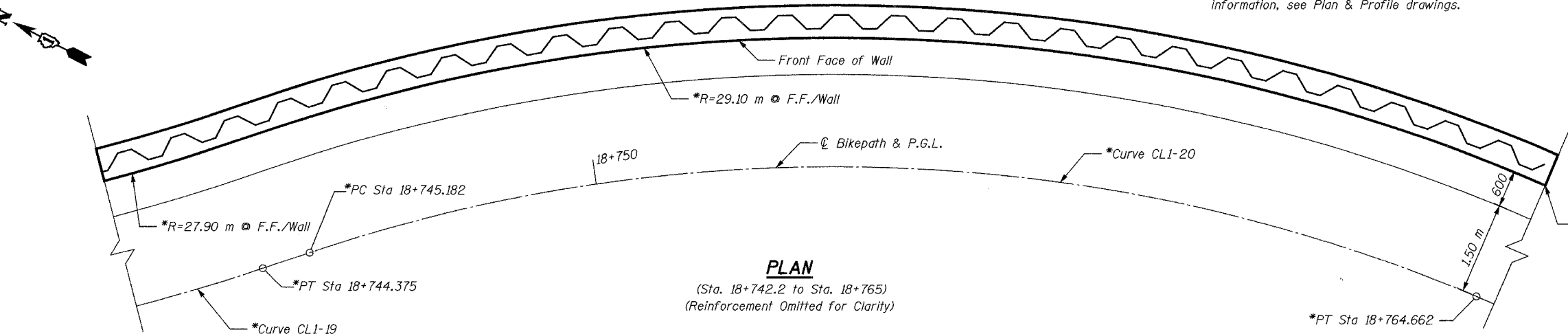

PLAN
(Sta. 18+742.2 to Sta. 18+765)
(Reinforcement Omitted for Clarity)

BILL OF MATERIAL

Bar	No.	Size	Length	Shape
h210(E)	13	#15	7.70 m	—
h211(E)	26	#15	8.79 m	—
u203(E)	90	#15	1.45 m	⊏
v207(E)	27	#15	1.89 m	—
v208(E)	26	#15	2.62 m	—
v209(E)	27	#15	2.25 m	—
Concrete Structures			Cu. M	17.6
Reinforcement Bars, Epoxy Coated			kg	1,010
Structure Excavation			Cu. M	13.5
Permanent Steel Sheet Piling			Sq. M	134
Pipe Handrail			Meter	24

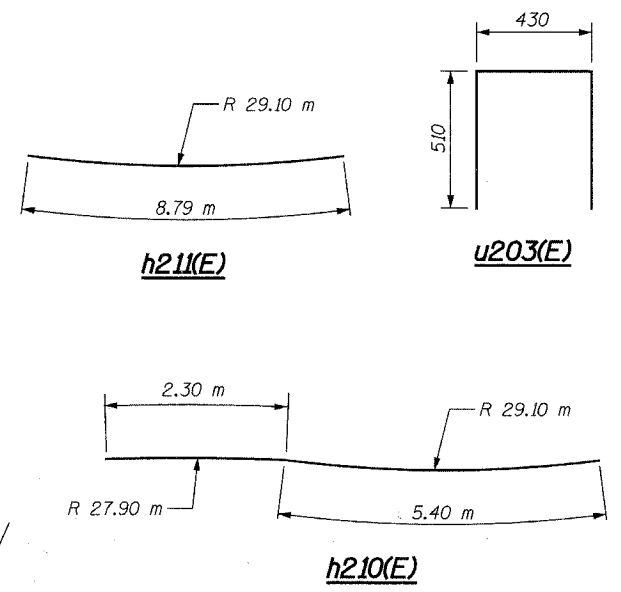

NOTES:
For Notes see Sheet S7.

SHEET S9 of S33

REVISIONS		NAME	DATE
NO.	DESCRIPTION		

URS 1701 GOLF ROAD, SUITE 1000 TEL (847) 228-0707
ROLLING MEADOWS, IL 60008 FAX (847) 228-1115

VILLAGE OF OAKBROOK
SALT CREEK GREENWAY TRAIL
RET. WALL STA. 18+742.2 TO 18+765
PLAN & ELEVATION

DATE: 06/30/05
DESIGNED BY: MDS
DRAWN BY: MDS
CHECKED BY: GAT

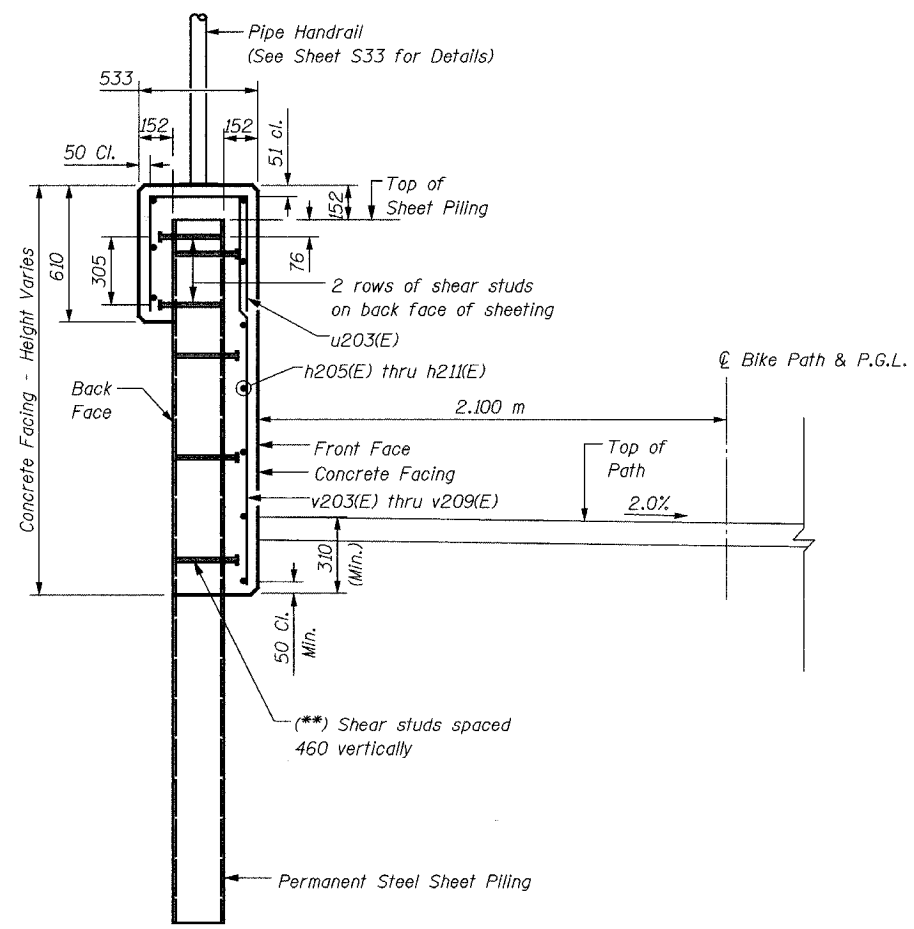

SECTION THRU WEST WALL
 (Section Sta. 18+675 to Sta. 18+696)
 (Section Sta. 18+727 to Sta. 18+765)

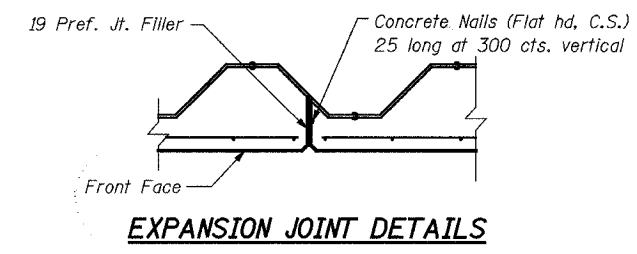

EXPANSION JOINT DETAILS

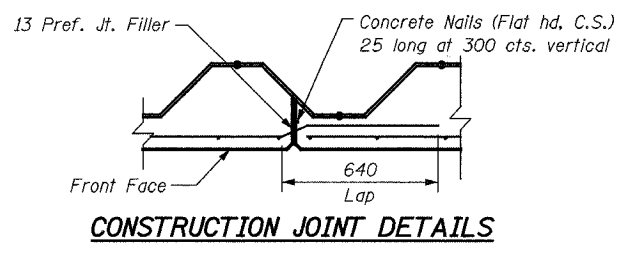

CONSTRUCTION JOINT DETAILS

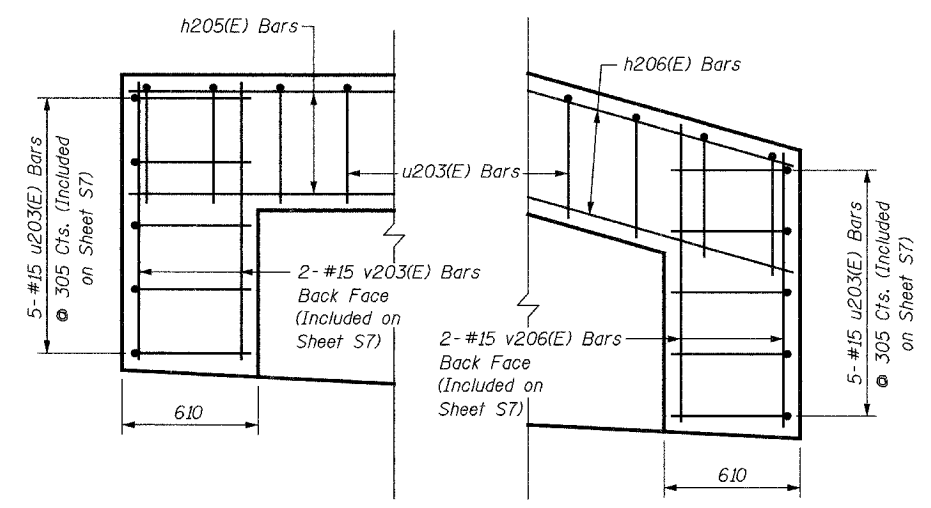

NORTH END SOUTH END

END CAP WALL DETAILS
 (Sta. 18+675 to 18+696)

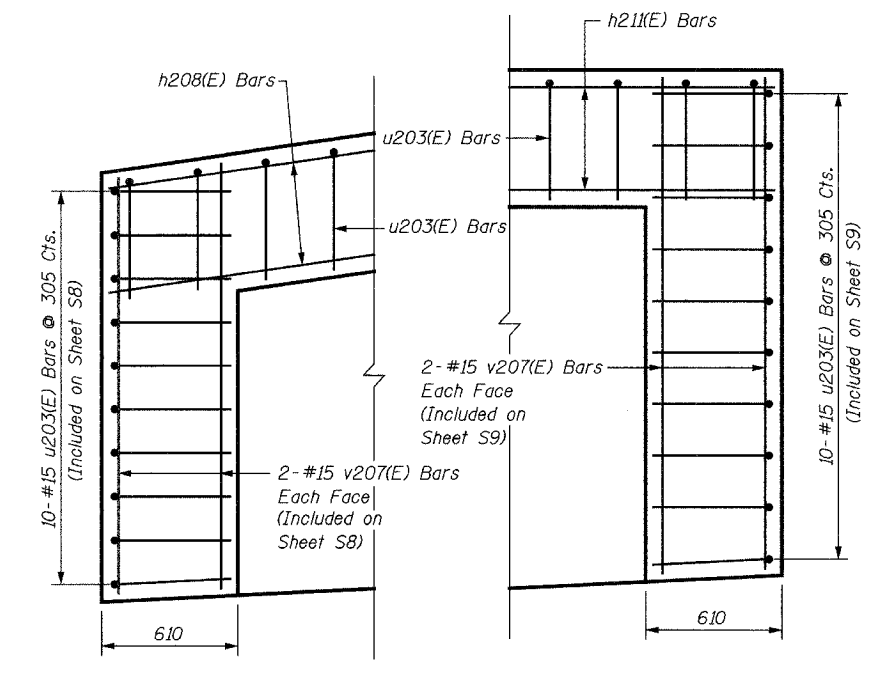

NORTH END SOUTH END

END CAP WALL DETAILS
 (Sta. 18+727 to 18+765)

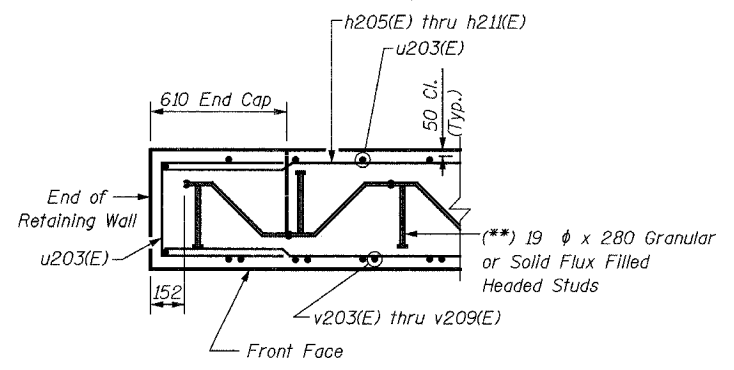

TYPICAL SECTION THRU CAP

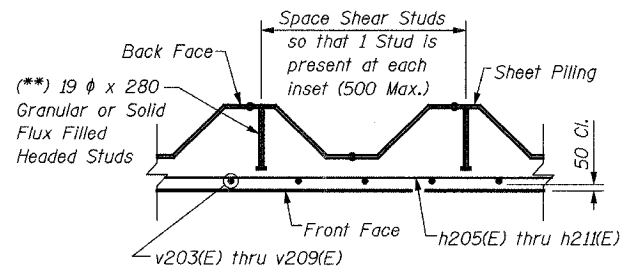

SECTION THRU WALL

() NOTE:**

Shear Studs shall be 19 dia. x 208 Granular or Solid Flux Filled Headed Studs conforming to 505.08 (m) of the Standard Specifications automatically end welded in the field to Sheet Piling. The cost of the studs is included in the cost of PERMANENT STEEL SHEET PILING.

NOTES:

See Sheet S7 for notes.

SHEET S10 of S33

REVISIONS		URS	1701 GOLF ROAD, SUITE 1000 ROLLING MEADOWS, IL 60008	TEL (847) 228-0707 FAX (847) 228-1115
NAME	DATE			
		VILLAGE OF OAKBROOK SALT CREEK GREENWAY TRAIL RET. WALL STA. 18+665 & 18+727 DETAILS		
		DATE: 06/30/05	DRAWN BY: MDS	
		DESIGNED BY: MDS	CHECKED BY: GAT	

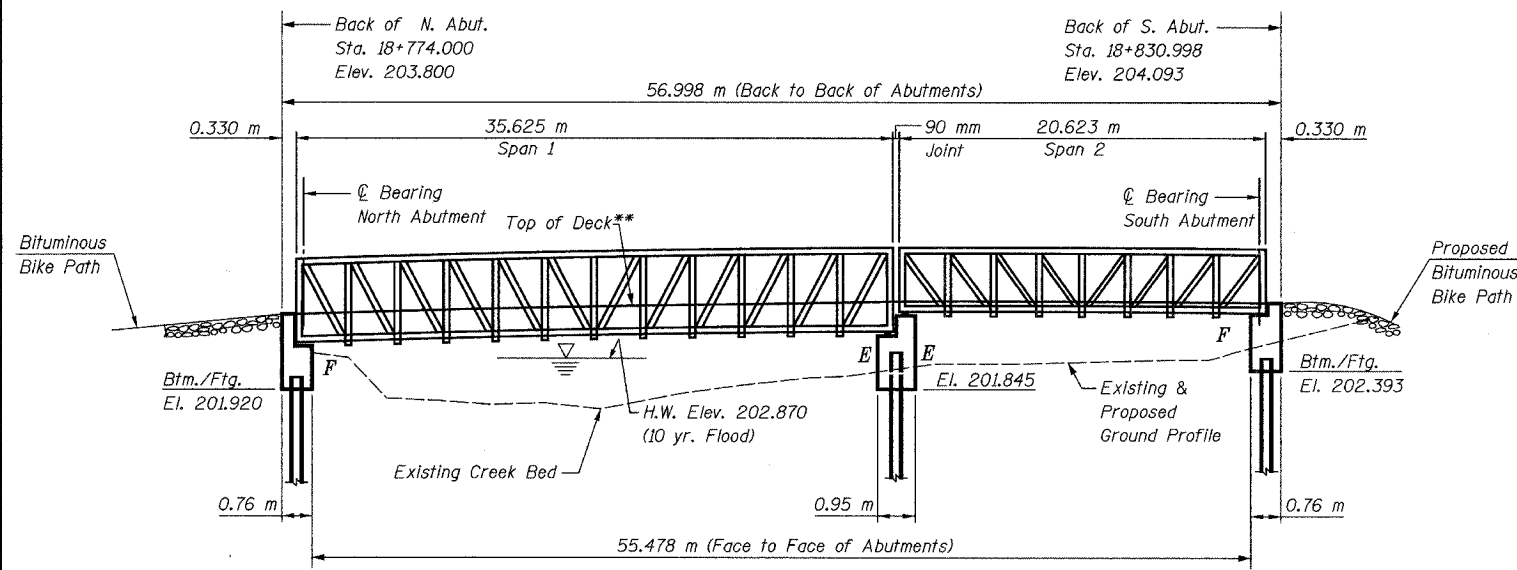

ELEVATION OF BRIDGE OVER SALT CREEK (WEIGH STATION)
(Looking East)

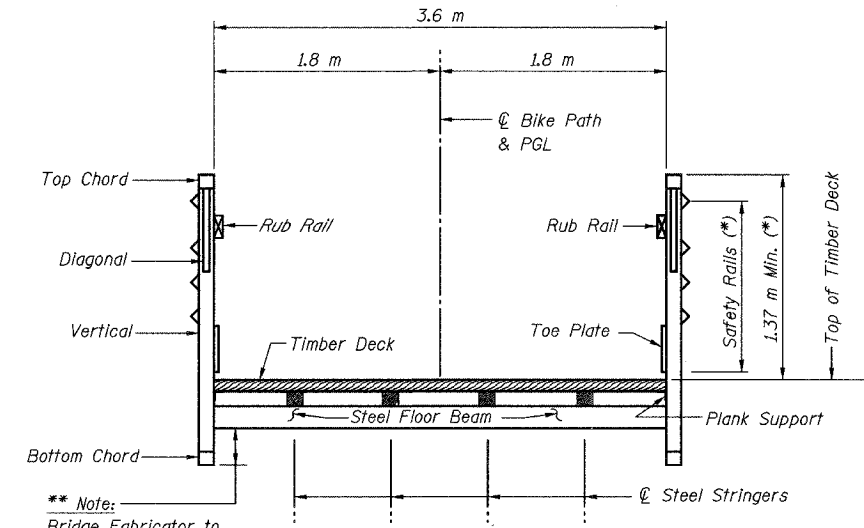

** Note:
Bridge fabricator to adjust depth so that bottom chord elevation is above high water elevation

TYPICAL CROSS SECTION

(*) Note:
If the top of the top chord is greater than 1.37 m above the top of deck, a second rub rail shall be placed at 1.37 m above top of deck.

TOTAL BILL OF MATERIAL

Item	Unit	Total
Structure Excavation	Cu. M	32
Concrete Structures	Cu. M	19.6
Reinforcement Bars, Epoxy Coated	kg	1370
Pedestrian Bridge Superstructure	Sq. M	204
Furnishing Steel Piles HP310x79	Meter	88
Driving Steel Piles	Meter	88
Test Pile Steel HP310x79	Each	1
Metal Shoes	Each	8

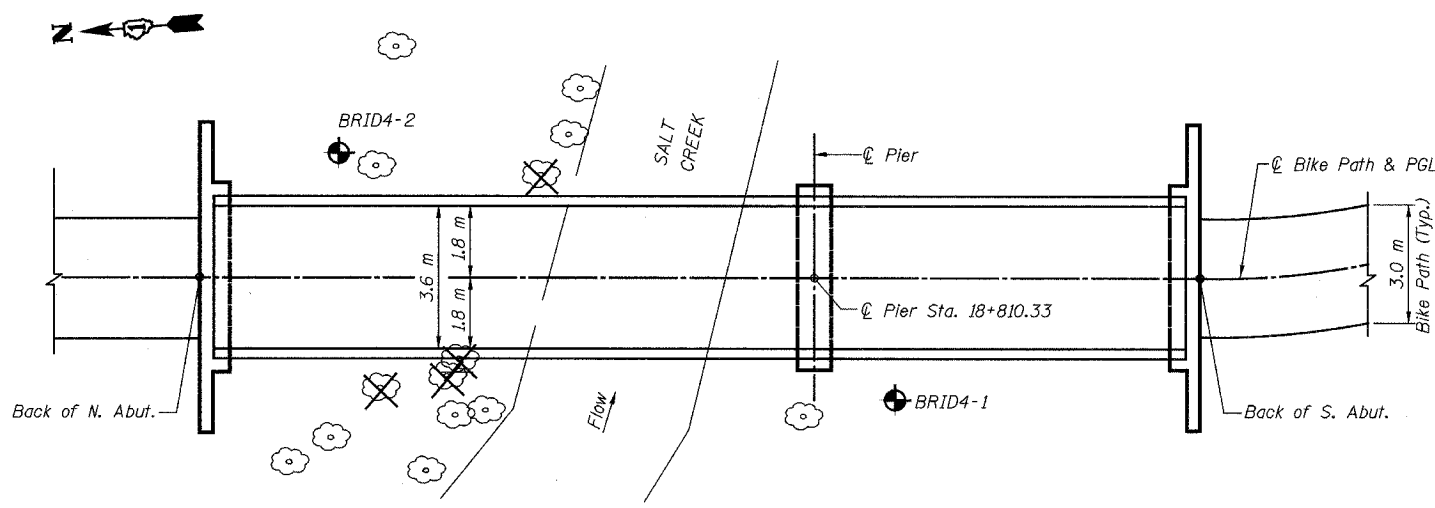

PLAN

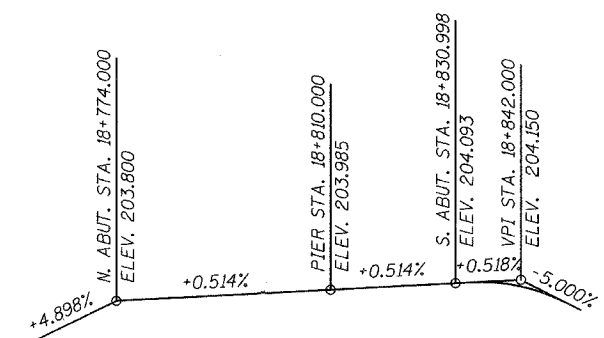

PROFILE GRADE

GENERAL NOTES:

- The superstructure, including all truss members, railings, toe plates, bearings, wood deck, and all attachments on superstructure, shall be designed and detailed by the Contractor.
- Reinforcement bars shall conform to the requirements of AASHTO M 31M, M 42M, or M 53M Grade 400.
- Bearing seat surfaces shall be constructed or adjusted to the designated elevations within a tolerance of 3 mm. Adjustment shall be made either by grinding the surface or by shimming the bearing. Two 3 mm adjusting shims, of the dimensions of the bottom bearing plate, shall be provided for each bearing in addition to all other plates or shims.
- The Contractor shall drive one (1) test pile in the permanent location at the North Abutment (center pile of group) as directed by the Engineer before ordering the remainder of the piles.
- The profile of the structure shall be as shown, and as specified in the Special Provisions for camber.
- The Contractor shall verify the final location of anchor bolts with the Bridge Manufacturer prior to construction and placement.
- All dimensions are in millimeters (mm) except as noted.
- For Soil Boring Logs, see Special Provisions.



Signature: [Signature]
Current Date: 7/2/05
License Expires: 11/30/06

"I certify that to the best of my knowledge and belief, this bridge design is structurally adequate for the design loading shown on the plans. The design is an economical one for the style of structure and complies with the requirements of the current 'AASHTO Standard Specifications for Highway Bridges'."

SEISMIC DATA

Seismic Performance Category (SPC) = A
Bedrock Acceleration Coefficient (A) = 0.04g
Site Coefficient (S) = 1.0

LEGEND

- Tree to Remain
- Tree to Be Removed
- Soil Boring

LOADING

Live Loading + Impact
4100 N/Sq. M Live Load
(May be adjusted for influence area)
50 kN Vehicle Load (MS-5 Truck)

DESIGN STRESSES

f'c = 24 MPa
fy = 400 MPa (Reinf.)

DESIGN SPECIFICATIONS

2002 AASHTO Standard Specifications for Highway Bridges, 17th Edition
Illinois Department of Transportation Standard Specifications for Road & Bridge Construction, Adopted January 1, 2002 and Supplemental Specifications and Recurring Special Provisions adopted January 1, 2004.
AASHTO Guide Specifications for the Design of Pedestrian Bridges, 1997 Edition.

CLASSIFICATION

Pedestrian/Bicycle Bridge

SHEET S11 of S33

REVISIONS		NAME	DATE
NO.	DESCRIPTION		

URS 1701 GOLF ROAD, SUITE 1000 TEL (847) 228-0707
ROLLING MEADOWS, IL 60008 FAX (847) 228-1115

VILLAGE OF OAKBROOK
**SALT CREEK GREENWAY TRAIL
PEDESTRIAN BRIDGE, STA. 18+802.5
GENERAL PLAN AND ELEVATION**

DATE: 06/30/05
DESIGNED BY: MDS
DRAWN BY: MDS
CHECKED BY: GAT

BILL OF MATERIAL

Bar	No.	Size	Length	Shape
h20(E)	2	#15	8.08 m	
h202(E)	20	#15	2.42 m	
h203(E)	4	#15	7.40 m	
p20(E)	14	#15	4.68 m	
s20(E)	16	#15	3.48 m	
s202(E)	16	#15	3.53 m	
v20(E)	12	#15	2.75 m	
Concrete Structures			Cu. M	6.7
Reinforcement Bars, Epoxy Coated			kg	480
Furnishing Steel Pile HP310x79			Meter	22
Driving Steel Piles			Meter	22
Test Pile Steel HP310x79			Each	1
Metal Shoes			Each	2
Structure Excavation			Cu. M	20

LEGEND

E.F. = Each Face

MIN. BAR LAP

#15 = 890

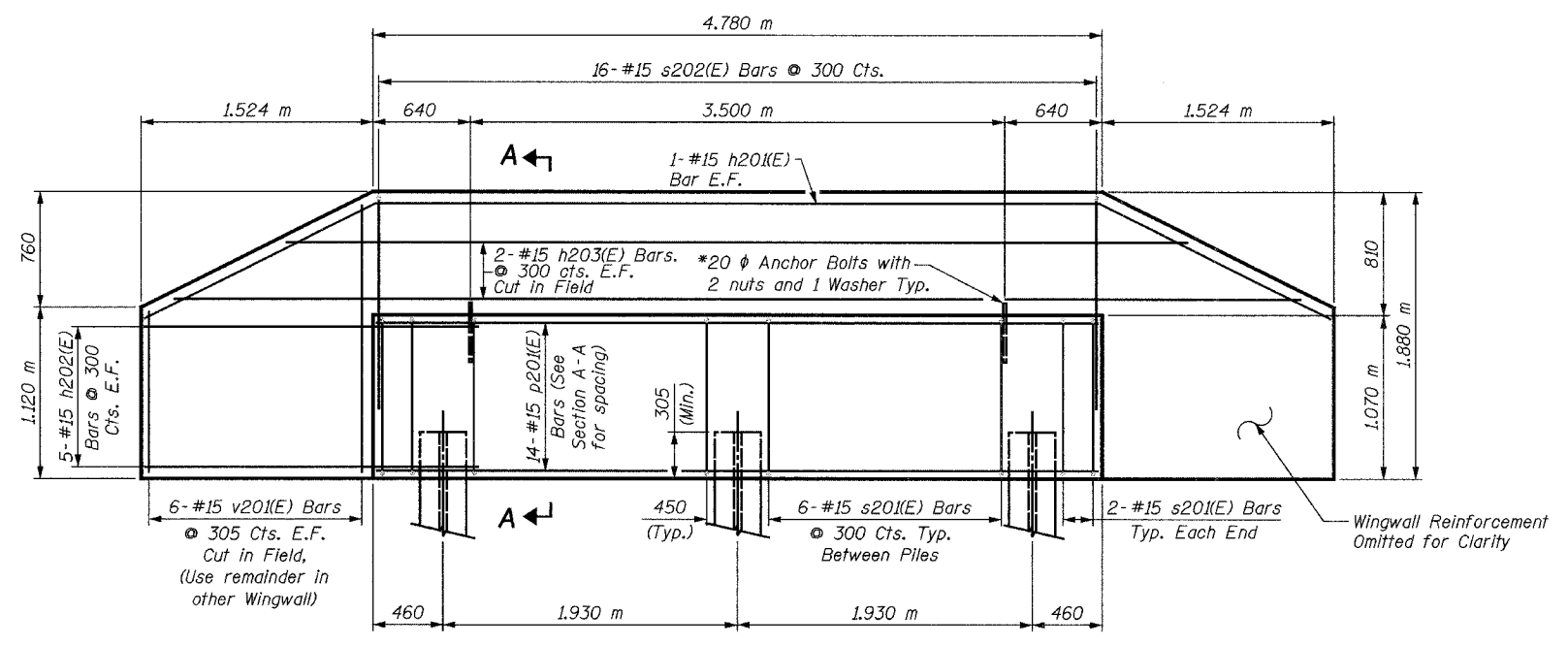

ELEVATION

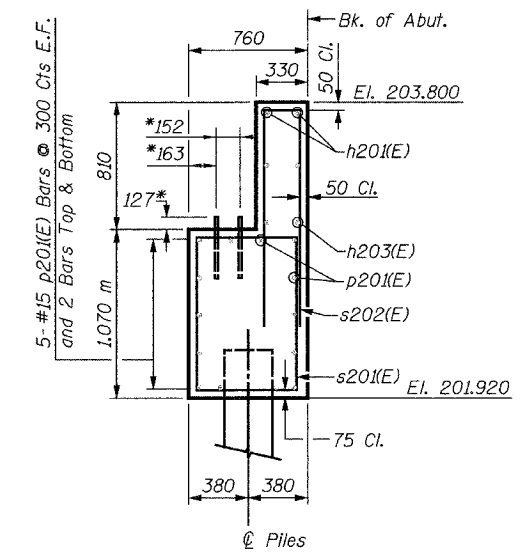

SECTION A-A

* Anchor bolt size and locations shall be checked against the bridge fabricator's requirements prior to setting them.

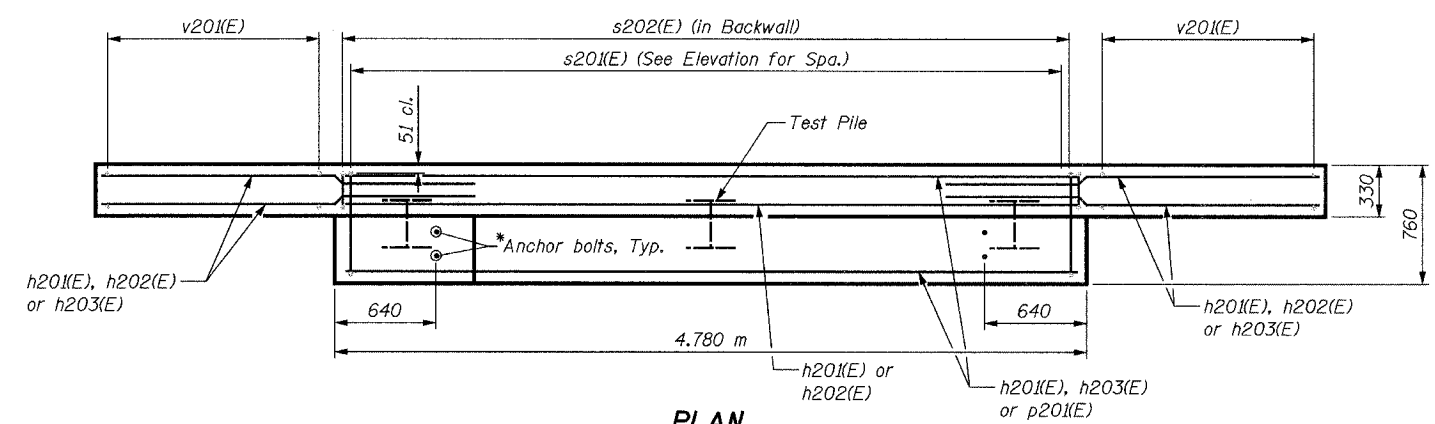

PLAN

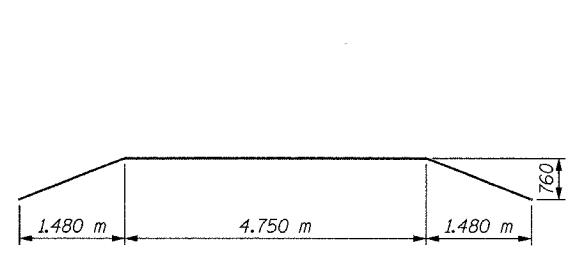

BAR h20(E)

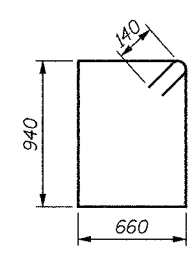

BAR s20(E)

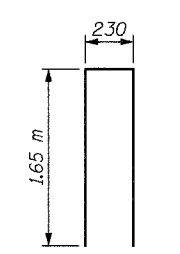

BAR s202(E)

PILE DATA:

Type: HP310x79
 Capacity: Driven to Refusal
 Est. Length: 11 m
 No. Required: 2 + 1 Test Pile
 Test Pile shall be a permanent pile driven at the North Abutment

NOTES:

- Space reinforcement in cap to miss anchor bolts.
- All edges shall have standard 20 mm chamfers except as noted.
- For Anchor Bolt Details, see Sheet S32.
- There shall be no splicing of longitudinal bars. Bars shall be ordered full length.
- Bars designated (E) shall be epoxy coated.

SHEET S12 of S33

REVISIONS		NAME	DATE

1701 GOLF ROAD, SUITE 1000
 ROLLING MEADOWS, IL 60008
 TEL (847) 228-0707
 FAX (847) 228-1115

VILLAGE OF OAKBROOK
SALT CREEK GREENWAY TRAIL
PEDESTRIAN BRIDGE, STA. 18+802.5
NORTH ABUTMENT DETAILS

DATE: 06/30/05
DESIGNED BY: MDS

DRAWN BY: MDS
CHECKED BY: CAT

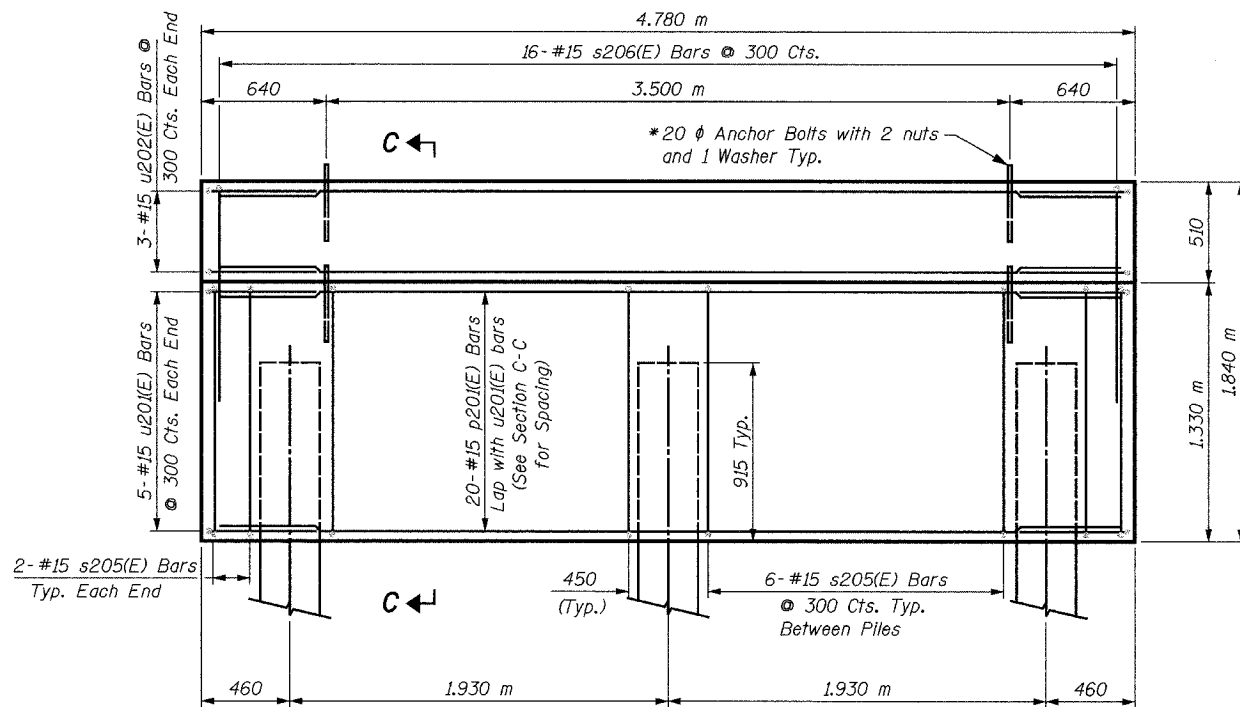

ELEVATION

PILE DATA:

Type: HP310x79
 Capacity: Driven to Refusal
 Est. Length: 11 m
 No. Required: 3

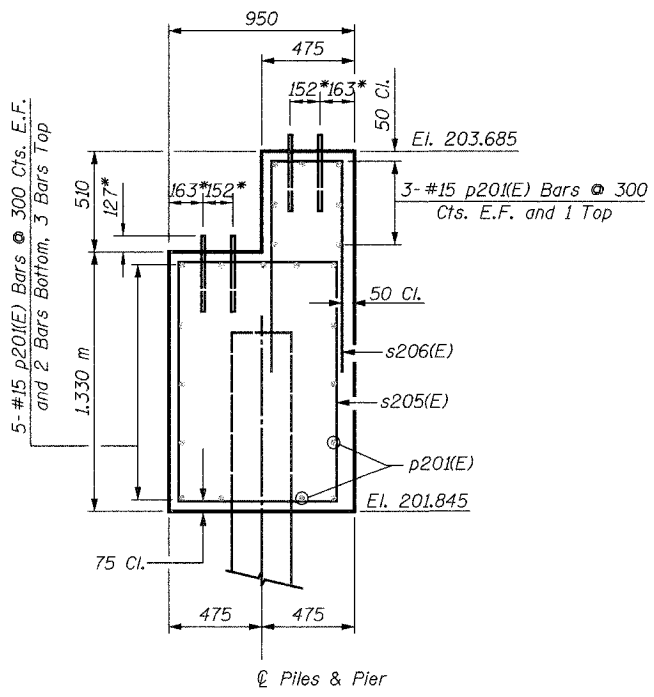

SECTION C-C

* Anchor bolt size and locations shall be checked against the bridge fabricator's requirements prior to setting them.

BILL OF MATERIAL

Bar	No.	Size	Length	Shape
p201(E)	22	#15	4.68 m	—
s205(E)	16	#15	4.36 m	□
s206(E)	16	#15	3.07 m	□
u201(E)	10	#15	2.65 m	□
u202(E)	6	#15	2.17 m	□
Concrete Structures		Cu. M	6.1	
Reinforcement Bars, Epoxy Coated		kg	420	
Furnishing Steel Piles HP310x79		Meter	33	
Driving Steel Piles		Meter	33	
Metal Shoes		Each	3	
Structure Excavation		Cu. M	5	

LEGEND

E.F. = Each Face

MIN. BAR LAP

#15 = 890

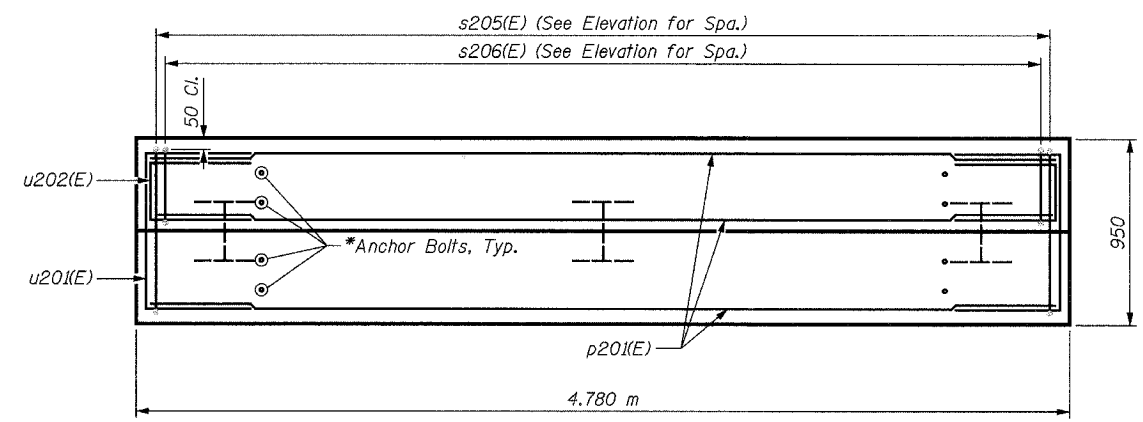

PLAN

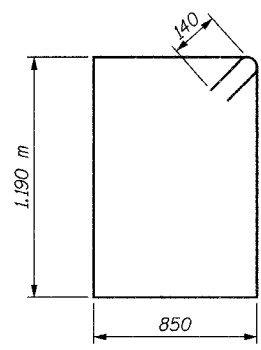

BAR s205(E)

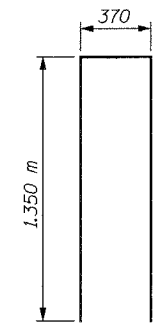

BAR s206(E)

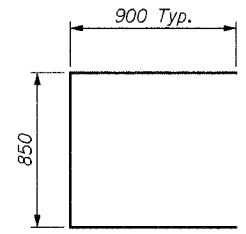

BAR u201(E)

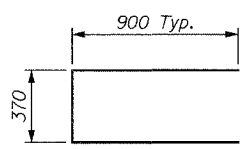

BAR u202(E)

NOTES:

- Space reinforcement in cap to miss anchor bolts.
- All edges shall have standard 20 mm chamfers except as noted.
- For Anchor Bolt Details, see Sheet S32.
- There shall be no splicing of longitudinal bars. Bars shall be ordered full length.
- Bars designated (E) shall be epoxy coated.

SHEET S13 of S33

REVISIONS		NAME	DATE	URS 1701 GOLF ROAD, SUITE 1000 ROLLING MEADOWS, IL 60008 TEL (847) 228-0707 FAX (847) 228-1115
NO.	DESCRIPTION			
				VILLAGE OF OAKBROOK SALT CREEK GREENWAY TRAIL PEDESTRIAN BRIDGE, STA. 18+802.5 PIER DETAILS
				DATE: 06/30/05 DESIGNED BY: MDS DRAWN BY: MDS CHECKED BY: GAT

BILL OF MATERIAL

Bar	No.	Size	Length	Shape
h201(E)	2	#15	8.08 m	
h202(E)	24	#15	2.42 m	
h204(E)	2	#15	5.56 m	
p201(E)	16	#15	4.68 m	
s203(E)	16	#15	4.14 m	
s204(E)	16	#15	2.51 m	
v202(E)	12	#15	2.44 m	
Concrete Structures		Cu. M	6.9	
Reinforcement Bars, Epoxy Coated		kg	470	
Furnishing Steel Piles HP310x79		Meter	33	
Driving Steel Piles		Meter	33	
Metal Shoes		Each	3	
Structure Excavation		Cu. M	7	

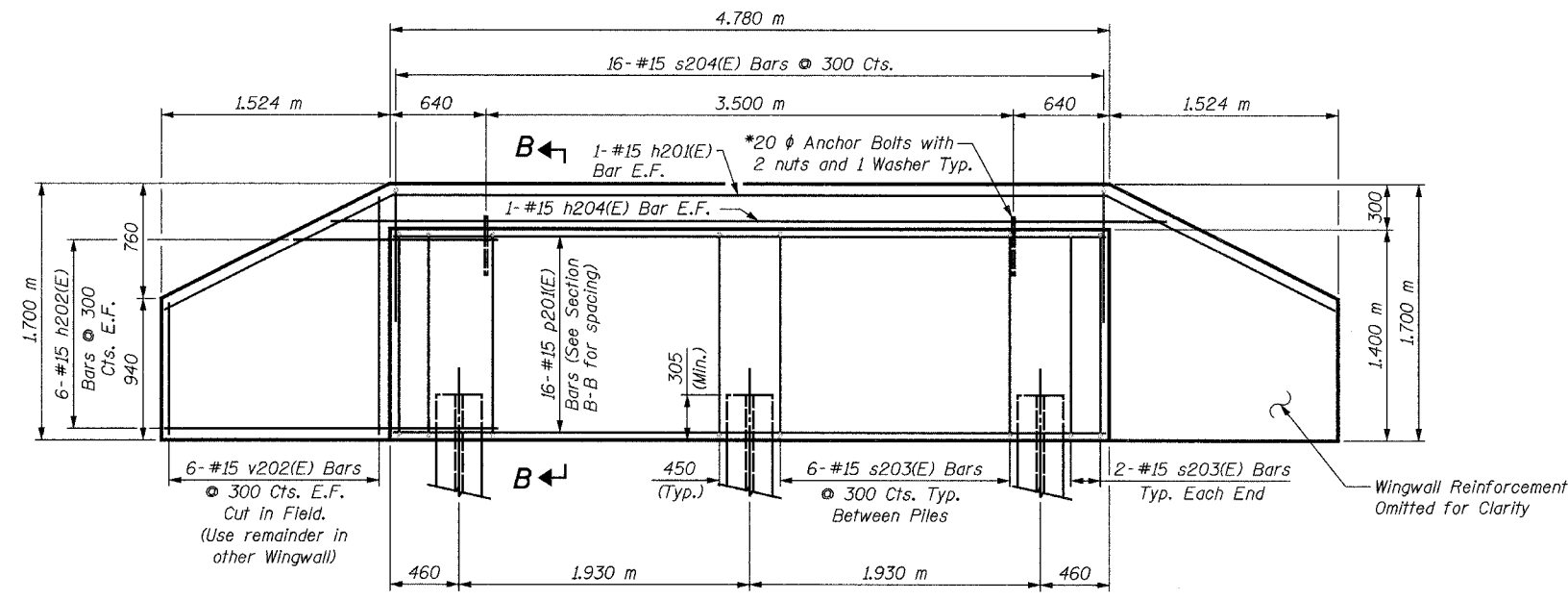

ELEVATION

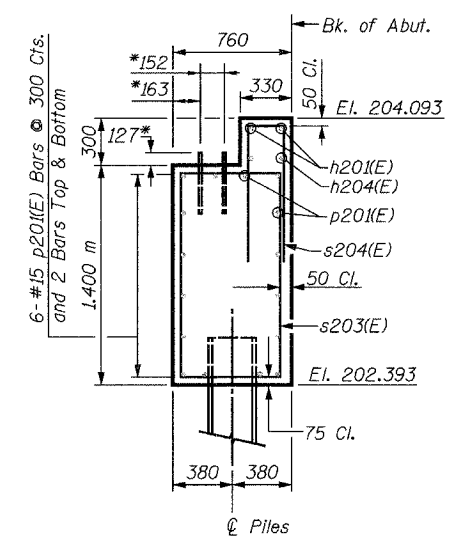

SECTION B-B

* Anchor bolt size and locations shall be checked against the bridge fabricator's requirements prior to setting them.

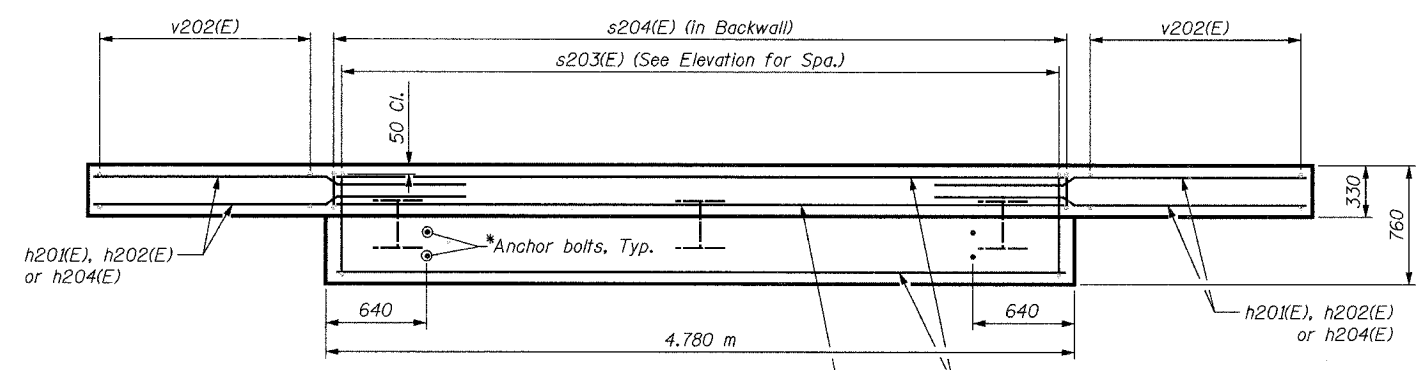

PLAN

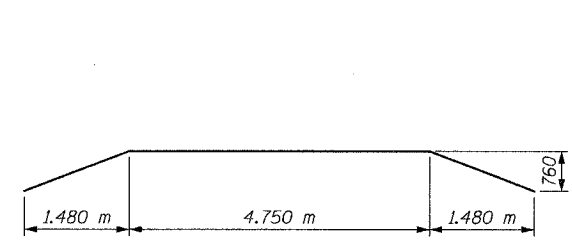

BAR h201(E)

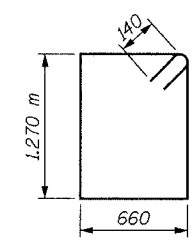

BAR s203(E)

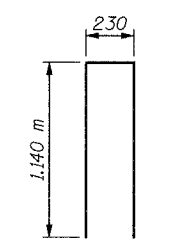

BAR s204(E)

PILE DATA:

Type: HP310x79
Capacity: Driven to Refusal
Est. Length: 11 m
No. Required: 3

LEGEND

E.F. = Each Face

MIN. BAR LAP

#15 = 890

NOTES:

- Space reinforcement in cap to miss anchor bolts.
- All edges shall have standard 20 mm chamfers except as noted.
- For Anchor Bolt Details, see Sheet S32.
- There shall be no splicing of longitudinal bars. Bars shall be ordered full length.
- Bars designated (E) shall be epoxy coated.

SHEET S14 of S33

REVISIONS		NAME	DATE	1701 GOLF ROAD, SUITE 1000 ROLLING MEADOWS, IL 60008 TEL (847) 228-0707 FAX (847) 228-1115
NAME	DATE			
				VILLAGE OF OAKBROOK SALT CREEK GREENWAY TRAIL PEDESTRIAN BRIDGE, STA. 18+802.5 SOUTH ABUTMENT DETAILS
				DATE: 06/30/05 DESIGNED BY: MDS DRAWN BY: MDS CHECKED BY: GAT

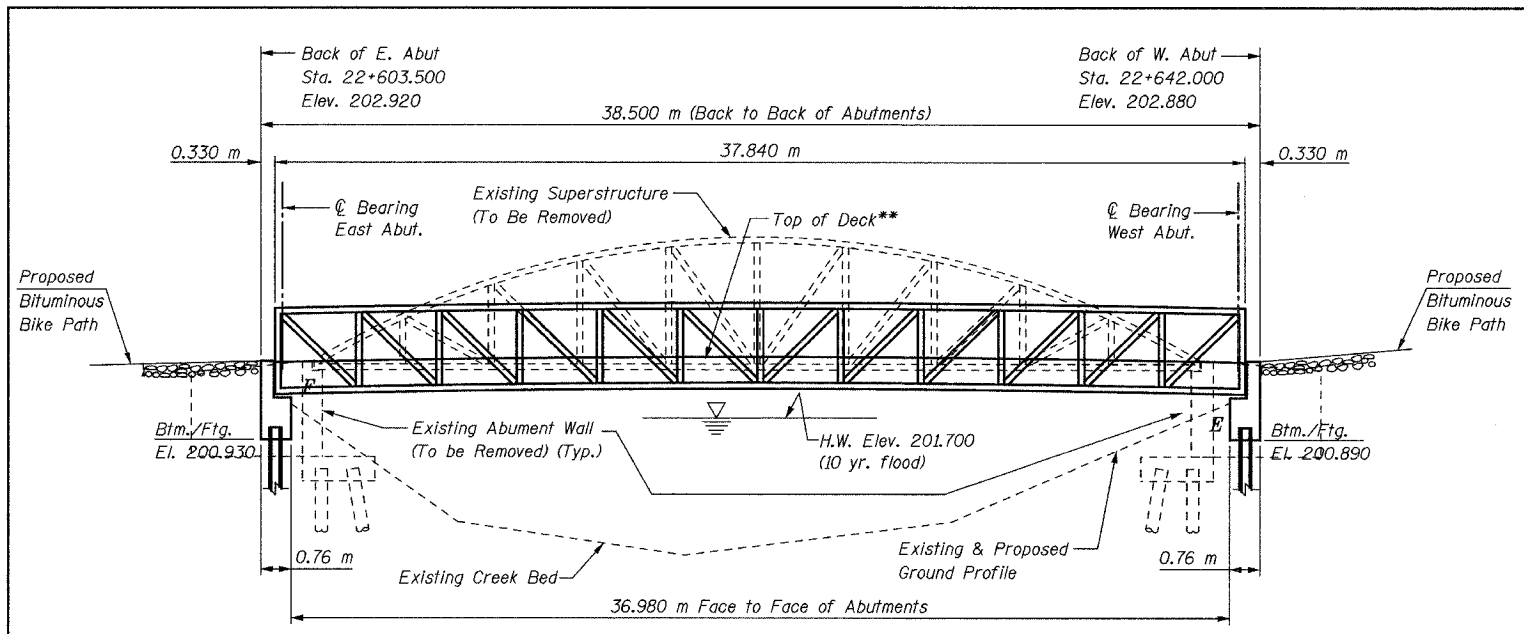

ELEVATION OF BRIDGE OVER SALT CREEK (ELDRIDGE PARK)
 (Looking South)

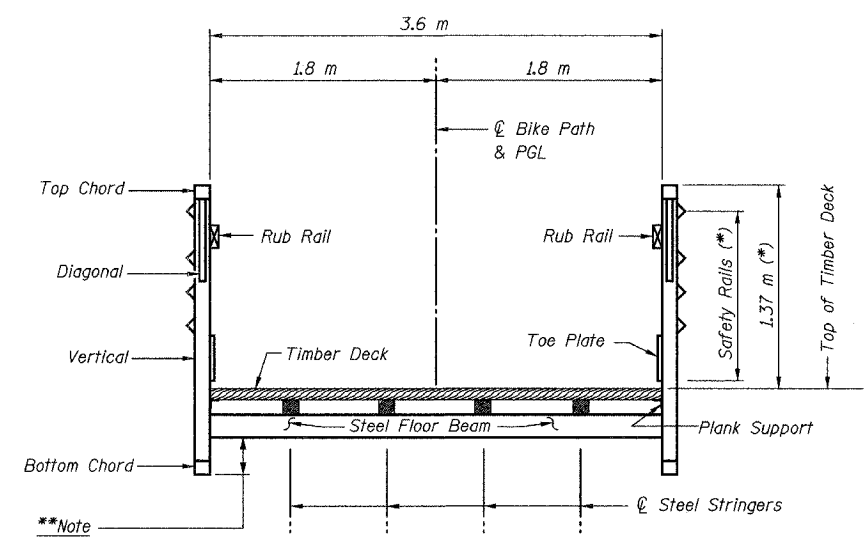

TYPICAL CROSS SECTION

**Note: Bridge Fabricator to adjust depth so that bottom chord elevation is above high water elevation.
 (*) Note: If the top of the chord is greater than 1.37 m above the top of deck, a second rub rail shall be placed at 1.37 m above top of deck.

TOTAL BILL OF MATERIAL

Item	Unit	Total
Structure Excavation	Cu. M	42
Concrete Structures	Cu. M	13.9
Reinforcement Bars, Epoxy Coated	kg	990
Pedestrian Bridge Superstructure	Sq. M	139
Furnishing Steel Piles HP310x79	Meter	100
Driving Steel Piles	Meter	100
Test Pile Steel HP310x79	Each	1
Metal Shoes	Each	5
Concrete Removal	Cu. M	10
Removal of Existing Superstructures	Each	1

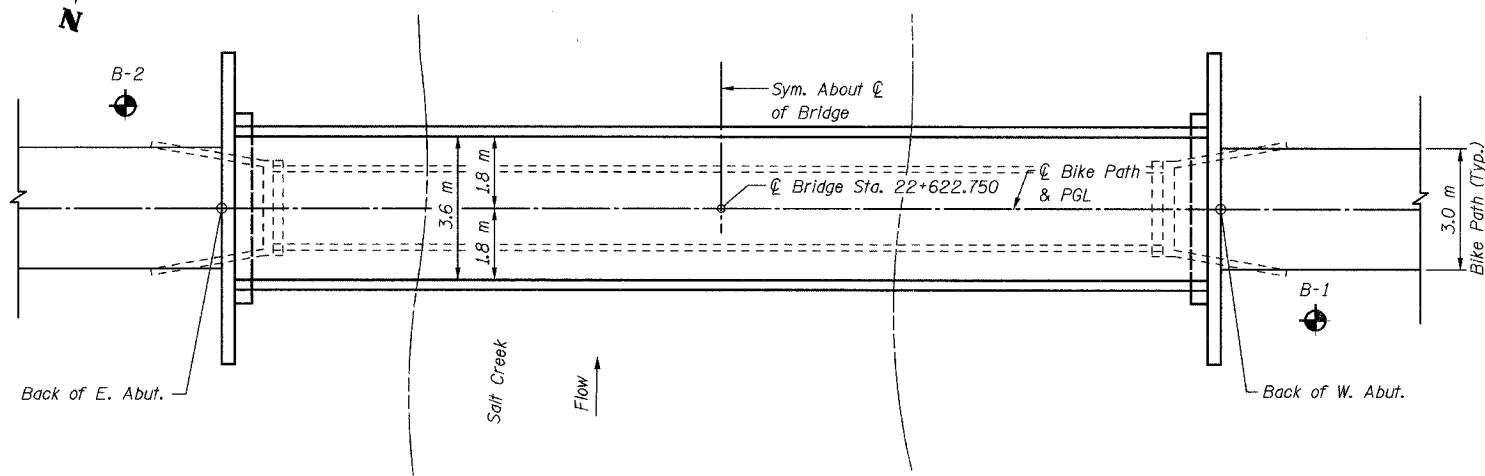

PLAN

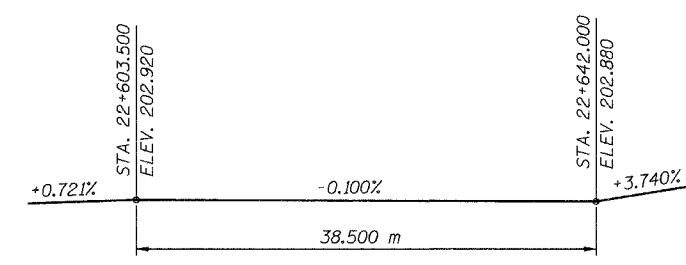

PROFILE GRADE

GENERAL NOTES:

- The superstructure, including all truss members, railings, toe plates, bearings, wood deck, and all attachments on superstructure, shall be designed and detailed by the Contractor.
- Reinforcement bars shall conform to the requirements of AASHTO M 31M, M 42M, or M 53M Grade 400.
- Bearing seat surfaces shall be constructed or adjusted to the designated elevations within a tolerance of 3 mm. Adjustment shall be made either by grinding the surface or by shimming the bearing. Two 3 mm adjusting shims, of the dimensions of the bottom bearing plate, shall be provided for each bearing in addition to all other plates or shims.
- The Contractor shall drive one (1) test pile in the permanent location at the West Abutment (center pile of group) as directed by the Engineer before ordering the remainder of the piles.
- The profile of the structure shall be as shown, and as specified in the Special Provisions for camber.
- The Contractor shall verify the final location of anchor bolts with the Bridge Manufacturer prior to construction and placement.
- All dimensions are in millimeters (mm) except as noted.
- For Soil Boring Logs see Special Provisions.



Signature: *G. Thomas*
 Current Date: 7/21/05
 License Expires: 11/30/06

"I certify that to the best of my knowledge, information and belief, this bridge design is structurally adequate for the design loading shown on the plans. The design is an economical one for the style of structure and complies with the requirements of the current 'AASHTO Standard Specifications for Highway Bridges'."

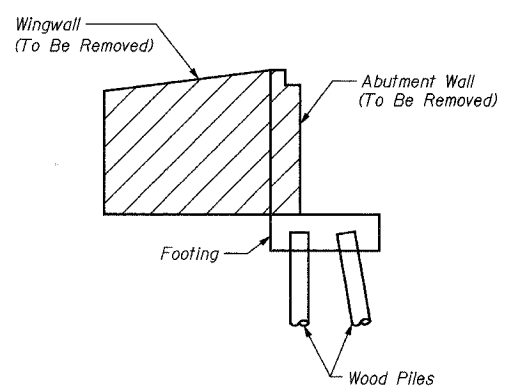

EXISTING ABUTMENT
 (Showing Removal)

DESIGN SPECIFICATIONS

2002 AASHTO Standard Specifications for Highway Bridges, 17th Edition.
 Illinois Department of Transportation Standard Specifications for Road & Bridge Construction, adopted January 1, 2002 and Supplemental Specifications and Recurring Special Provisions adopted January 1, 2004.
 AASHTO Guide Specifications for the Design of Pedestrian Bridges, 1997 Edition.

SEISMIC DATA

Seismic Performance Category (SPC) = A
 Bedrock Acceleration Coefficient (A) = 0.04g
 Site Coefficient (S) = 1.0

CLASSIFICATION

Pedestrian/Bicycle Bridge

DESIGN STRESSES

$f'_c = 24 \text{ MPa}$
 $f_y = 400 \text{ MPa (Reinf.)}$

LOADING

Live Loading + Impact
 4100 N/Sq. M Live Load
 (May be adjusted for influence area)
 50kN Vehicle Load (MS-5 Truck)

Equivalent Fluid Lateral Soil Pressure
 6.3 kN/Cu. M

LEGEND

- Soil Boring
- Concrete Removal

SHEET S15 of S33

REVISIONS		NAME	DATE
NO.	DESCRIPTION		

URS 1701 GOLF ROAD, SUITE 1000 TEL (847) 228-0707
 ROLLING MEADOWS, IL 60008 FAX (847) 228-1115

VILLAGE OF OAKBROOK
SALT CREEK GREENWAY TRAIL
PEDESTRIAN BRIDGE, STA 22+622.75
GENERAL PLAN AND ELEVATION

DATE: 06/30/05
 DESIGNED BY: MDS
 DRAWN BY: MDS
 CHECKED BY: GAT

BILL OF MATERIAL

Bar	No.	Size	Length	Shape
h301(E)	4	#15	8.08 m	
h302(E)	40	#15	2.42 m	
h303(E)	8	#15	7.72 m	
p301(E)	28	#15	4.68 m	
s301(E)	32	#15	3.48 m	
s302(E)	32	#15	3.75 m	
v301(E)	24	#15	3.02 m	
Concrete Structures			Cu. M	13.9
Reinforcement Bars, Epoxy Coated			kg	990
Furnishing Steel Piles HP310x79			Meter	100
Driving Steel Piles			Meter	100
Test Pile Steel HP310x79			Each	1
Metal Shoes			Each	5
Structure Excavation			Cu. M	42

LEGEND

E.F. = Each Face

MIN. BAR LAP

#15 = 890

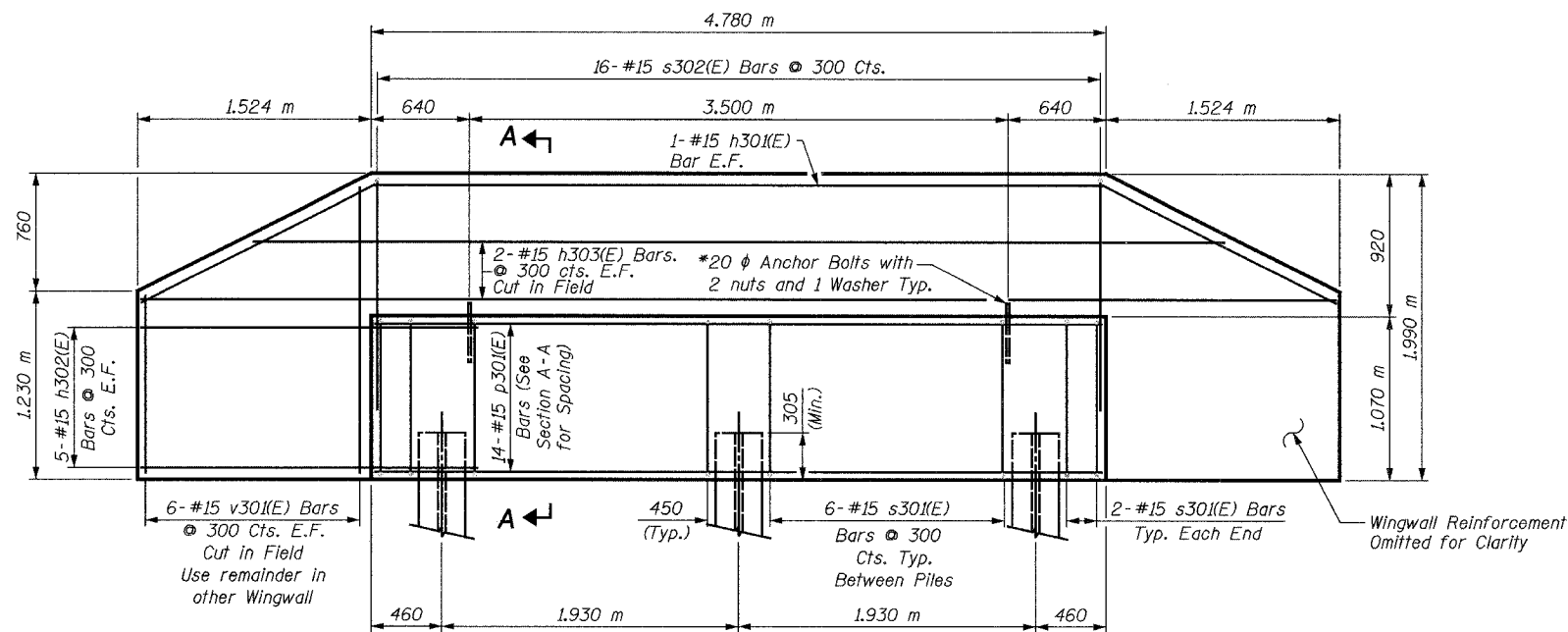

ELEVATION

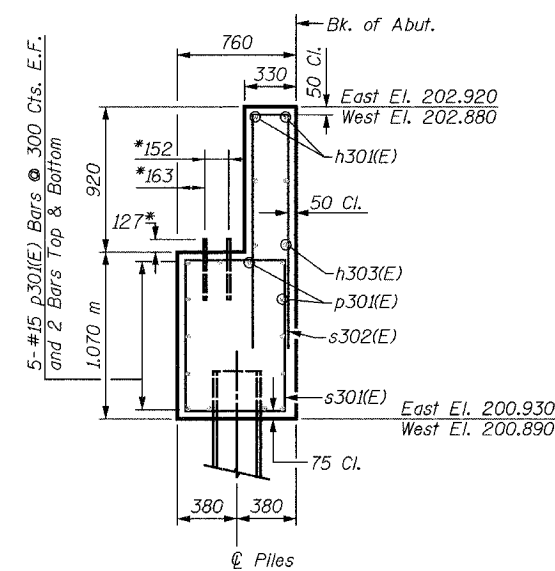

SECTION A-A

* Anchor bolt size and locations shall be checked against the bridge fabricator's requirements prior to setting them.

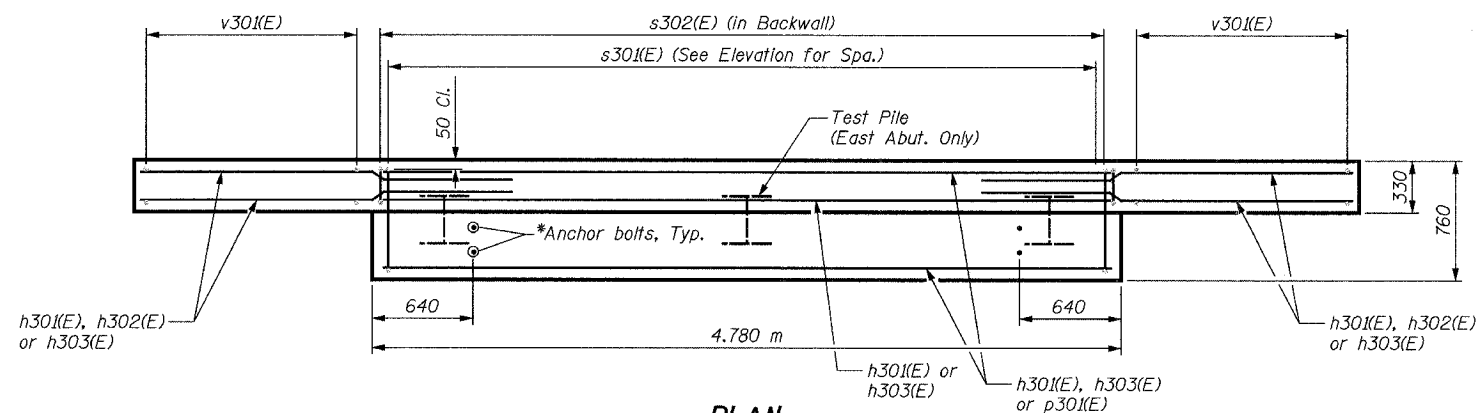

PLAN

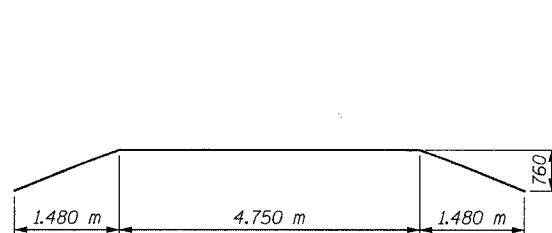

BAR h301(E)

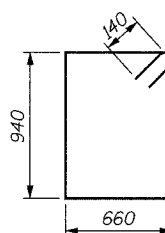

BAR s301(E)

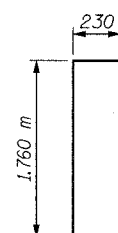

BAR s302(E)

PILE DATA:

Type: HP310x79
 Capacity: Driven to Refusal
 Est. Length: 20 m (E. Abut)
 20 m (W. Abut)
 No. Required: 2 + 1 Test Pile (E. Abut)
 3 (W. Abut)

(Test Pile shall be a permanent pile driven at the East Abutment)

NOTES:

- Space reinforcement in cap to miss anchor bolts.
- All edges shall have standard 20 mm chamfers except as noted.
- For Anchor Bolt Details, see Sheet S32.
- There shall be no splicing of longitudinal bars. Bars shall be ordered full length.
- Bars designated (E) shall be epoxy coated.

SHEET S16 of S33

REVISIONS		NAME	DATE	1701 GOLF ROAD, SUITE 1000 ROLLING MEADOWS, IL 60008 TEL (847) 228-0707 FAX (847) 228-1115
NAME	DATE			
				VILLAGE OF OAKBROOK SALT CREEK GREENWAY TRAIL PEDESTRIAN BRIDGE, STA. 22+622.75 ABUTMENT DETAILS

DATE: 06/30/05
 DESIGNED BY: MDS
 DRAWN BY: MDS
 CHECKED BY: GAT

TOTAL BILL OF MATERIAL

Item	Unit	Quantity
Concrete Structures	Cu. M	23.4
Reinforcement Bars, Epoxy Coated	kg	1,240
Structure Excavation	Cu. M	23
Permanent Steel Sheet Piling	Sq. M	142
Pipe Handrail	Meter	31

DESIGN LOADING

Equivalent Fluid Lateral Soil Pressure
6.3 kN/Cu. M

DESIGN STRESSES

$f'_c = 24 \text{ MPa}$
 $f_y = 400 \text{ MPa (Reinf.)}$
 $f_y = 270 \text{ MPa (Sheet Piling)}$

DESIGN SPECIFICATIONS

2002 AASHTO Standard Specifications for Highway Bridges, 17th Edition.

Illinois Department of Transportation Standard Specifications for Road & Bridge Construction, adopted January 1, 2002 and Supplemental Specifications and Recurring Special adopted January 1, 2004.

GENERAL NOTES:

1. Reinforcement bars shall conform to the requirements of AASHTO M 31M, M 42M or M 53M Grade 400.
2. Steel sheet piling shall conform to the requirements of Section 1006.05 of the Standard Specifications.
3. If the Contractor chooses to alter the sheet piling design requirements shown on the plans for lesser design requirements, then full design submittal including plan details and sealed calculations will be required for review and acceptance by the Engineer.
4. All dimensions are in millimeters (mm) except as noted.
5. For Soil Boring logs, see Special Provisions.
6. Any pre-excavation carried out for the placement of the sheet piling shall not extend below the bottom of concrete facing elevation.

SHEET S17 of S33

REVISIONS		NAME	DATE
NO.	DESCRIPTION		

URS 1701 GOLF ROAD, SUITE 1000 TEL (847) 228-0707
ROLLING MEADOWS, IL 60008 FAX (847) 228-1115

VILLAGE OF OAKBROOK
SALT CREEK GREENWAY TRAIL
ROOSEVELT RET. WALL "A"
GENERAL PLAN & ELEVATION

DATE: 06/30/05
DESIGNED BY: MDS
DRAWN BY: MDS
CHECKED BY: GAT

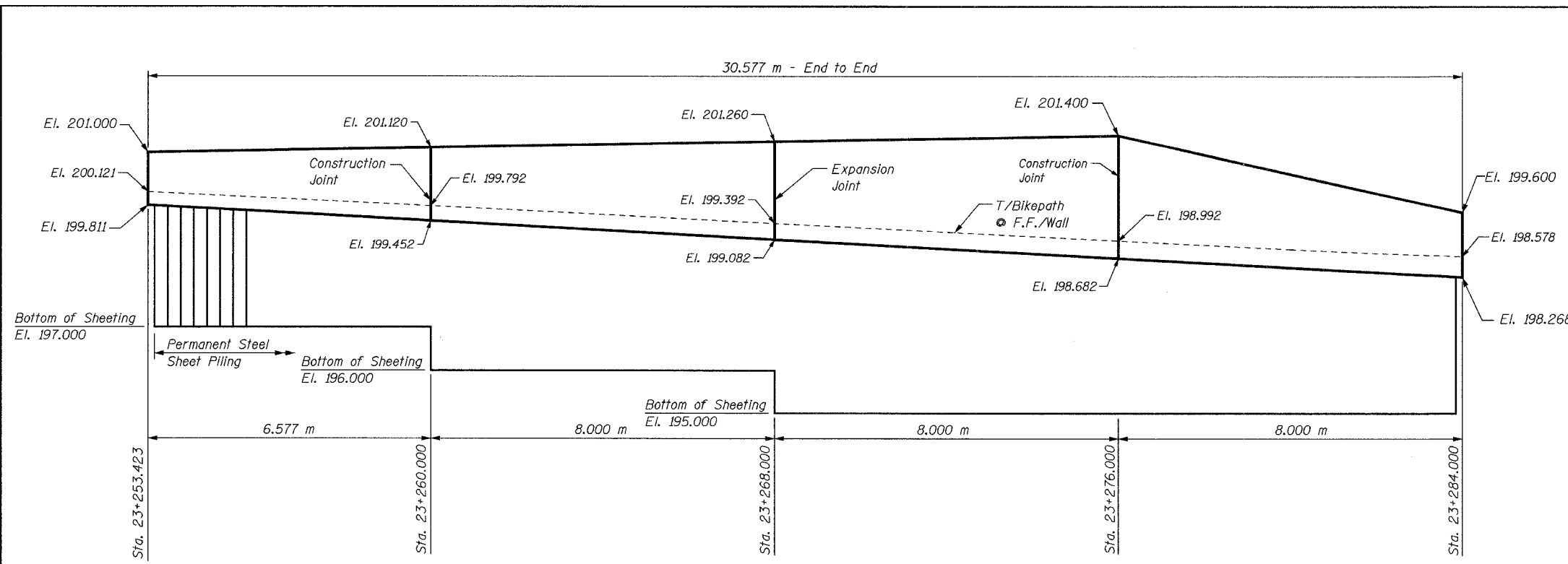

ELEVATION - RET. WALL "A"

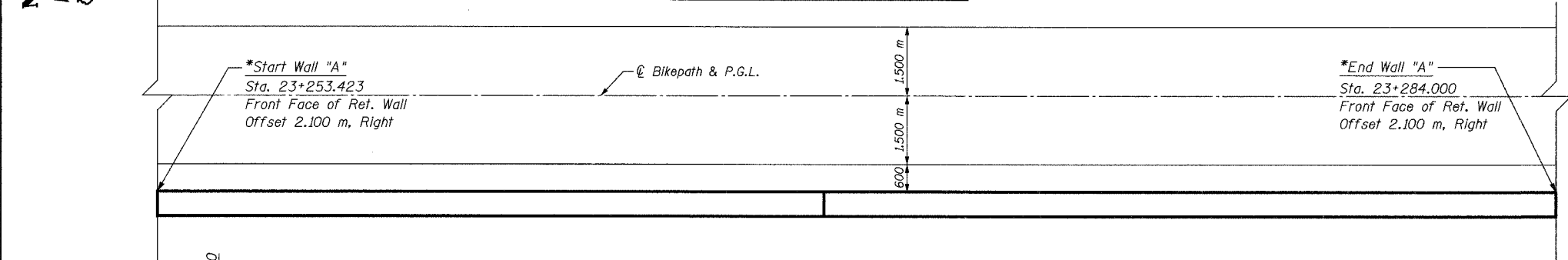

PLAN

***NOTE:**
For horizontal curve and alignment information, see Plan & Profile drawings.



Signature: *George A. Tapas*
Current Date: 7/21/05
License Expires: 11/30/06

"I certify that to the best of my knowledge, information and belief, this retaining wall design is structurally adequate for the design loading shown on the plans. The design is an economical one for the style of structure and complies with the requirements of the current 'AASHTO Standard Specifications for Highway Bridges'."

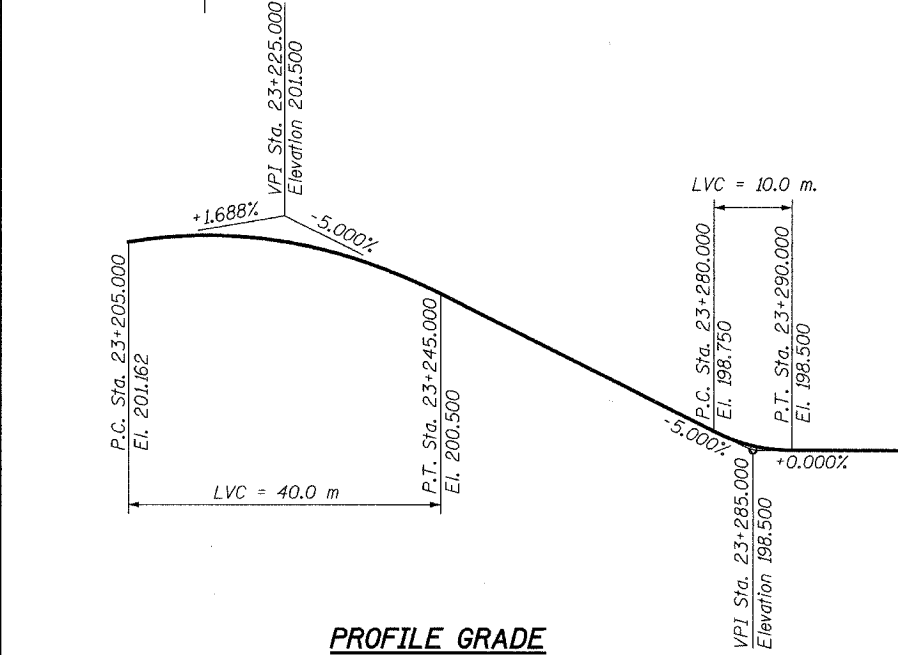

PROFILE GRADE

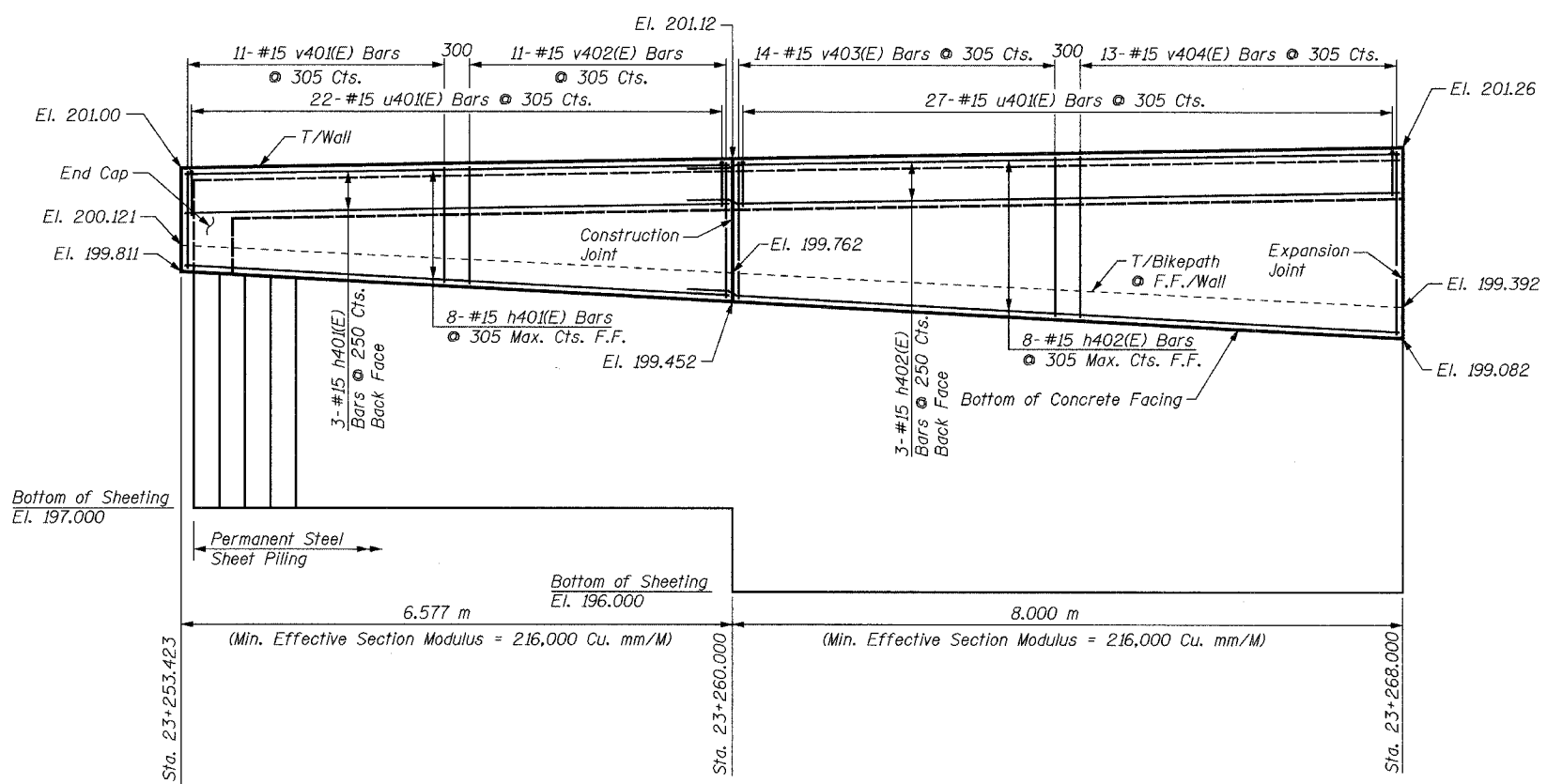

ELEVATION - WALL "A"
(Sta. 23+253.423 to Sta. 23+268)

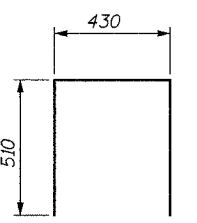

BAR u40(E)

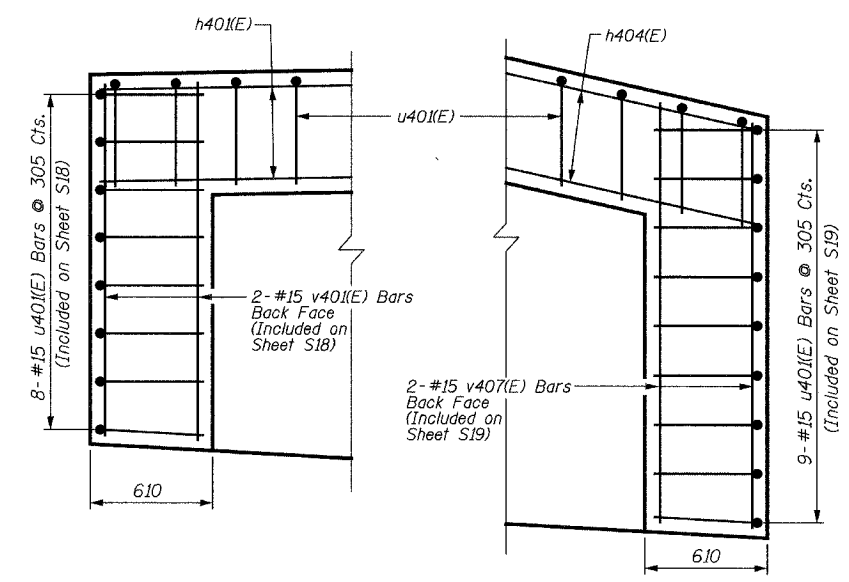

NORTH END **SOUTH END**
END CAP WALL DETAILS - WALL "A"

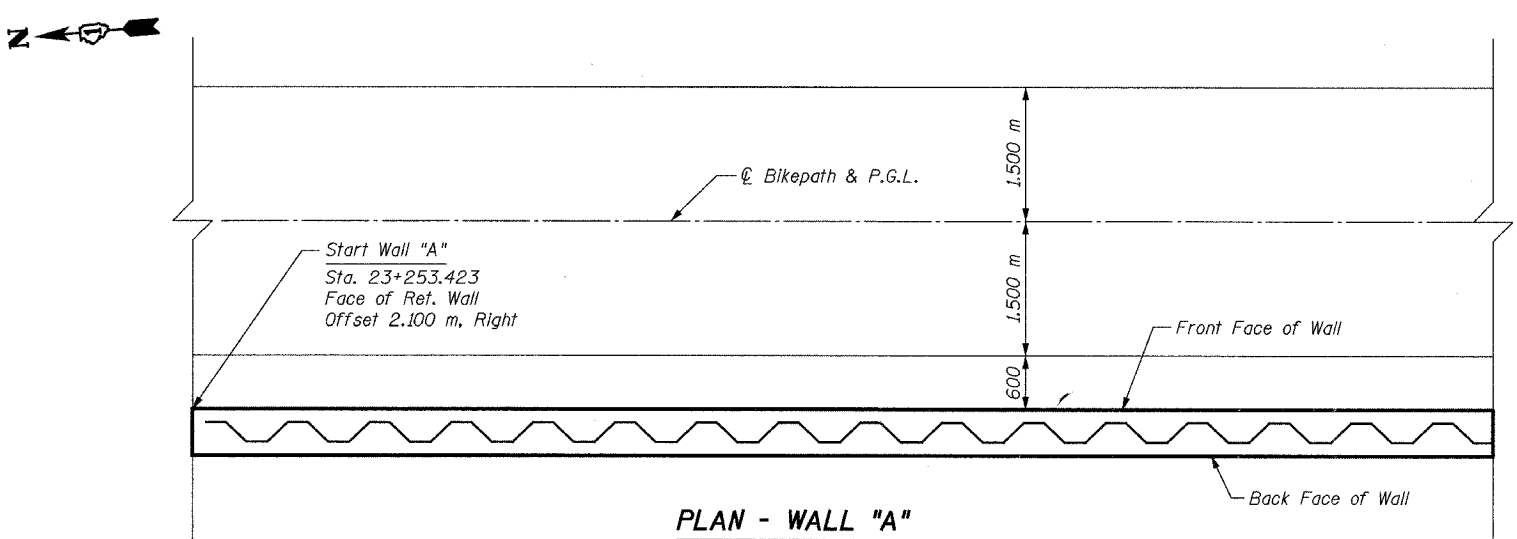

PLAN - WALL "A"
(Sta. 23+253.423 to Sta. 23+268)
(Reinforcement Omitted for Clarity)

BILL OF MATERIAL

Bar	No.	Size	Length	Shape
h40(E)	13	#15	6.48 m	—
h402(E)	11	#15	8.64 m	—
u40(E)	57	#15	1.45 m	□
v40(E)	11	#15	1.33 m	—
v402(E)	11	#15	1.56 m	—
v403(E)	14	#15	1.82 m	—
v404(E)	13	#15	2.08 m	—
Concrete Structures		Cu. M	11.4	
Reinforcement Bars, Epoxy Coated		kg	570	
Structure Excavation		Cu. M	14	
Permanent Steel Sheet Piling		Sq. M	58	
Pipe Handrail		Meter	15	

NOTES:

- Use Fan h(E) bars for even distribution over face of wall.
- Use Cut v(E) bars as necessary in field to fit.
- Minimum lap for #15 bar = 640 mm.
- All exposed edges of concrete shall have a 20 mm chamfer unless shown otherwise.
- For minimum effective section modulus properties for sheet piling sections, refer to special provision for Permanent Steel Sheet Piling.
- Work this sheet with Sheet S19.
- Bars designated (E) shall be epoxy coated.
- All dimensions are in millimeters (mm) unless otherwise noted.
- For Typical Section thru Wall, see Sheet S19.

SHEET S18 of S33

REVISIONS		NAME	DATE

URS 1701 GOLF ROAD, SUITE 1000 TEL (847) 228-0707
ROLLING MEADOWS, IL 60008 FAX (847) 228-1115

VILLAGE OF OAKBROOK
SALT CREEK GREENWAY TRAIL
WALL "A", STA. 23+253.423 TO
STA. 23+268, PLAN & ELEVATION

DATE: 06/30/05 DRAWN BY: MDS
DESIGNED BY: MDS CHECKED BY: GAT

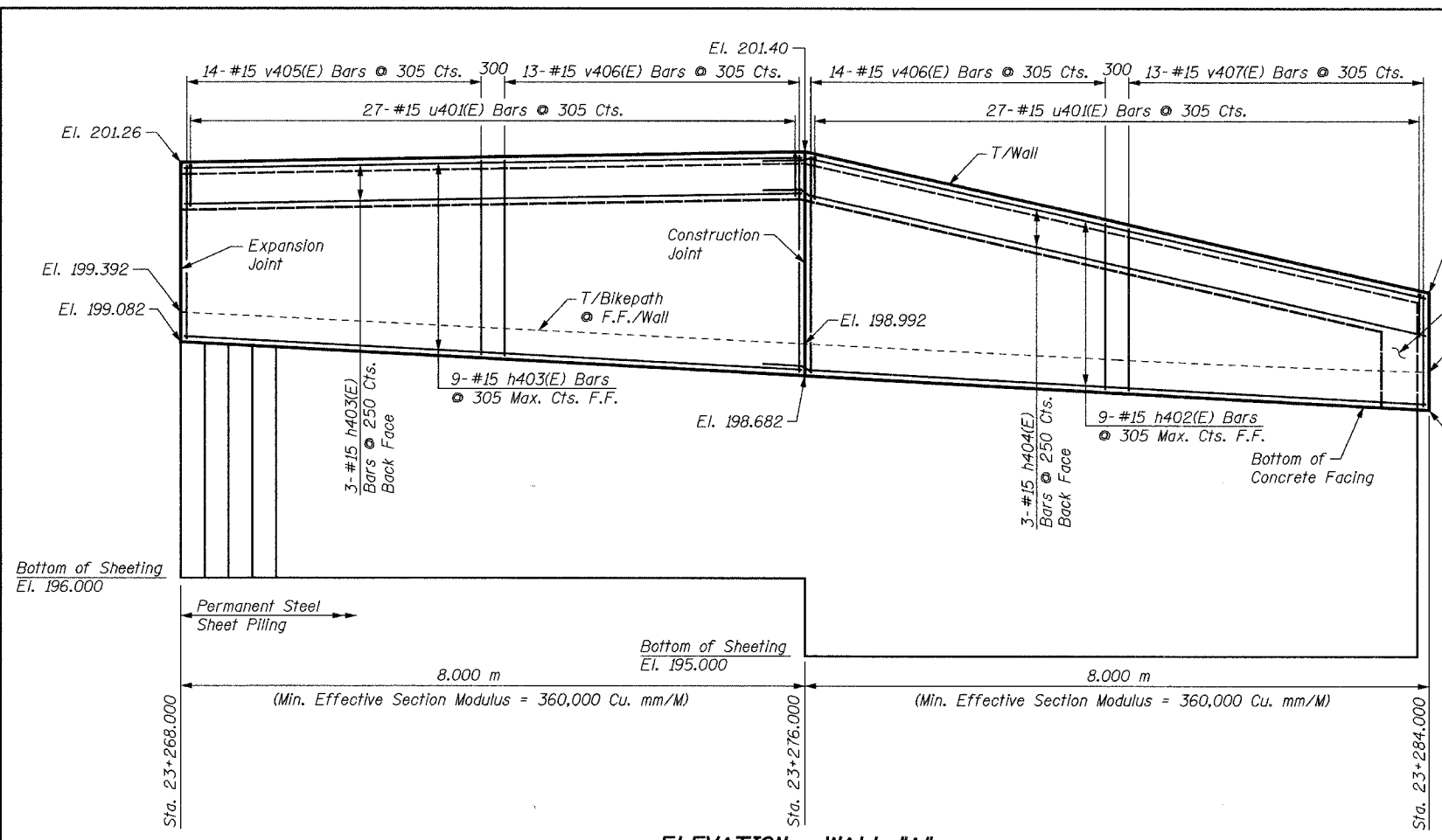

ELEVATION - WALL "A"
(Sta. 23+268 to Sta. 23+284)

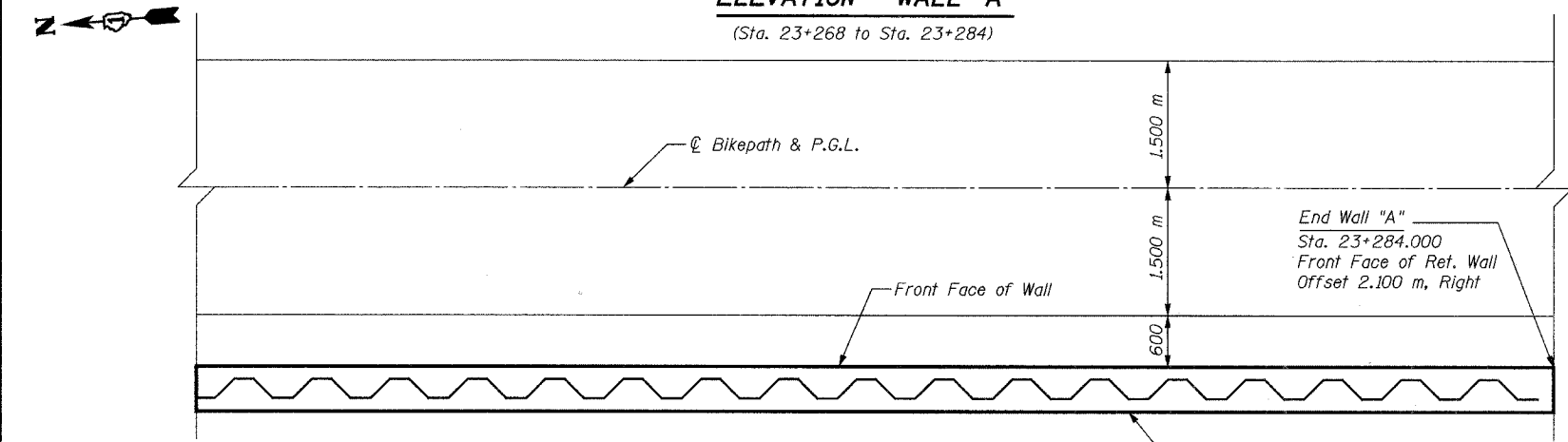

PLAN - WALL "A"
(Sta. 23+268 to Sta. 23+284)
(Reinforcement Omitted for Clarity)

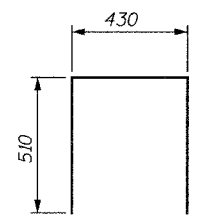

BAR u40(E)

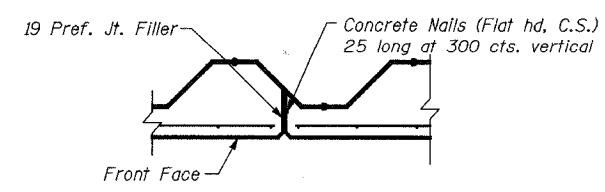

EXPANSION JOINT DETAIL

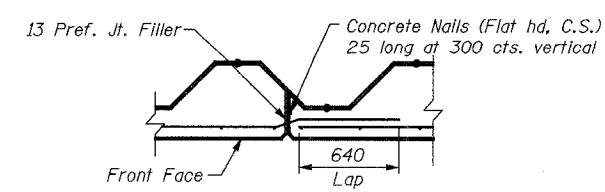

CONSTRUCTION JOINT DETAIL

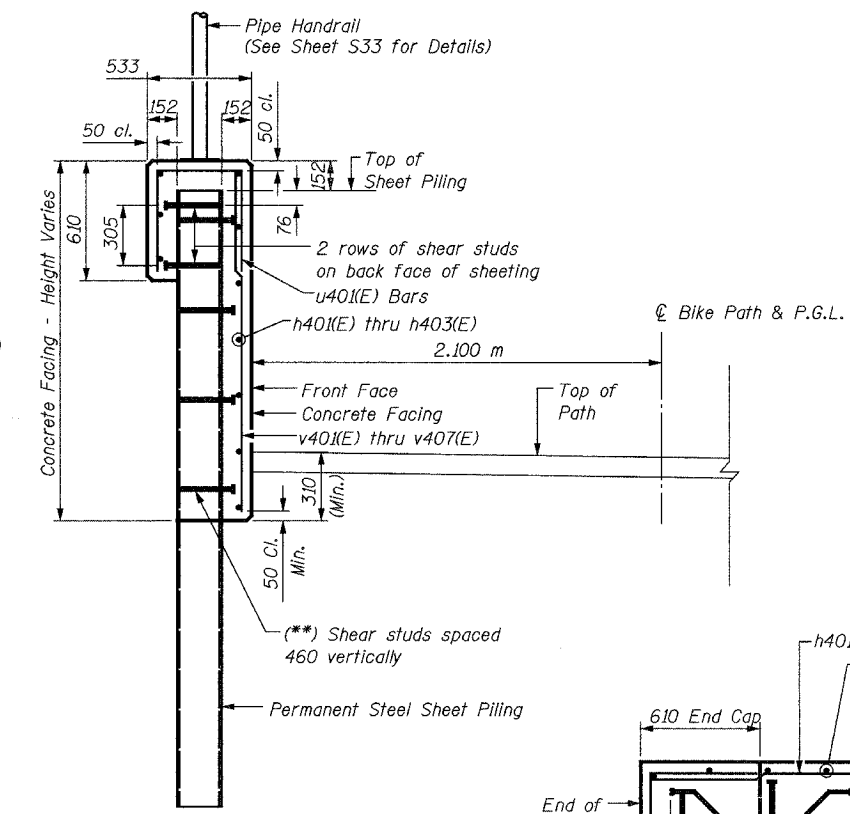

SECTION THRU WALL "A"
(Section Sta. 23+253.423 to Sta. 23+284)

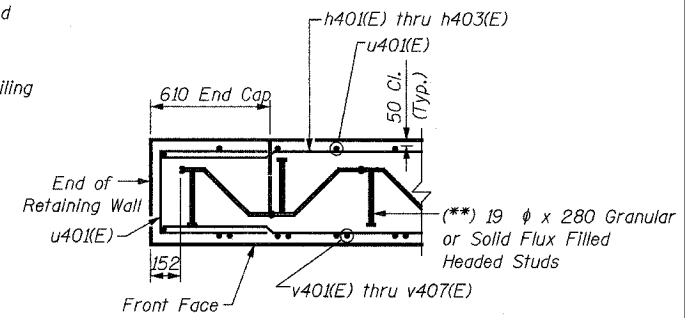

SECTION THRU CAP

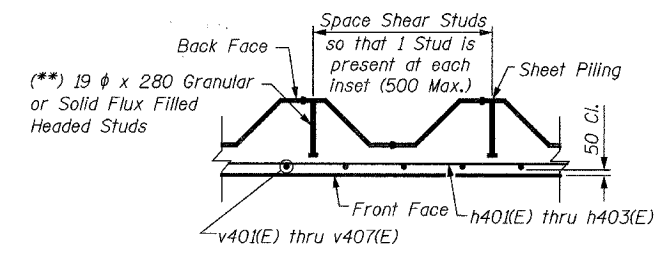

TYPICAL SECTION THRU WALL

() NOTE:**

Shear Studs shall be 19 dia. x 208 Granular or Solid Flux Filled Headed Studs conforming to 505.08 (m) of the Standard Specifications automatically end welded in the field to Sheet Piling. The cost of the studs is included in the cost of PERMANENT STEEL SHEET PILING.

BILL OF MATERIAL

Bar	No.	Size	Length	Shape
h402(E)	12	#15	8.64 m	—
h403(E)	12	#15	7.90 m	—
u40(E)	63	#15	1.45 m	□
v405(E)	14	#15	2.35 m	—
v406(E)	27	#15	2.62 m	—
v407(E)	15	#15	1.92 m	—
Concrete Structures		Cu. M	12.0	
Reinforcement Bars, Epoxy Coated		kg	670	
Structure Excavation		Cu. M	9	
Permanent Steel Sheet Piling		Sq. M	84	
Pipe Handrail		Meter	16	

NOTES:

For notes see Sheet S18.

REVISIONS			1701 GOLF ROAD, SUITE 1000 TEL (847) 228-0707 ROLLING MEADOWS, IL 60008 FAX (847) 228-1115	
NAME	DATE			
		VILLAGE OF OAKBROOK SALT CREEK GREENWAY TRAIL WALL "A", STA. 23+268 TO STA. 23+284, PLAN & ELEVATION		
		DATE: 06/30/05	DRAWN BY: MDS	
		DESIGNED BY: MDS	CHECKED BY: GAT	

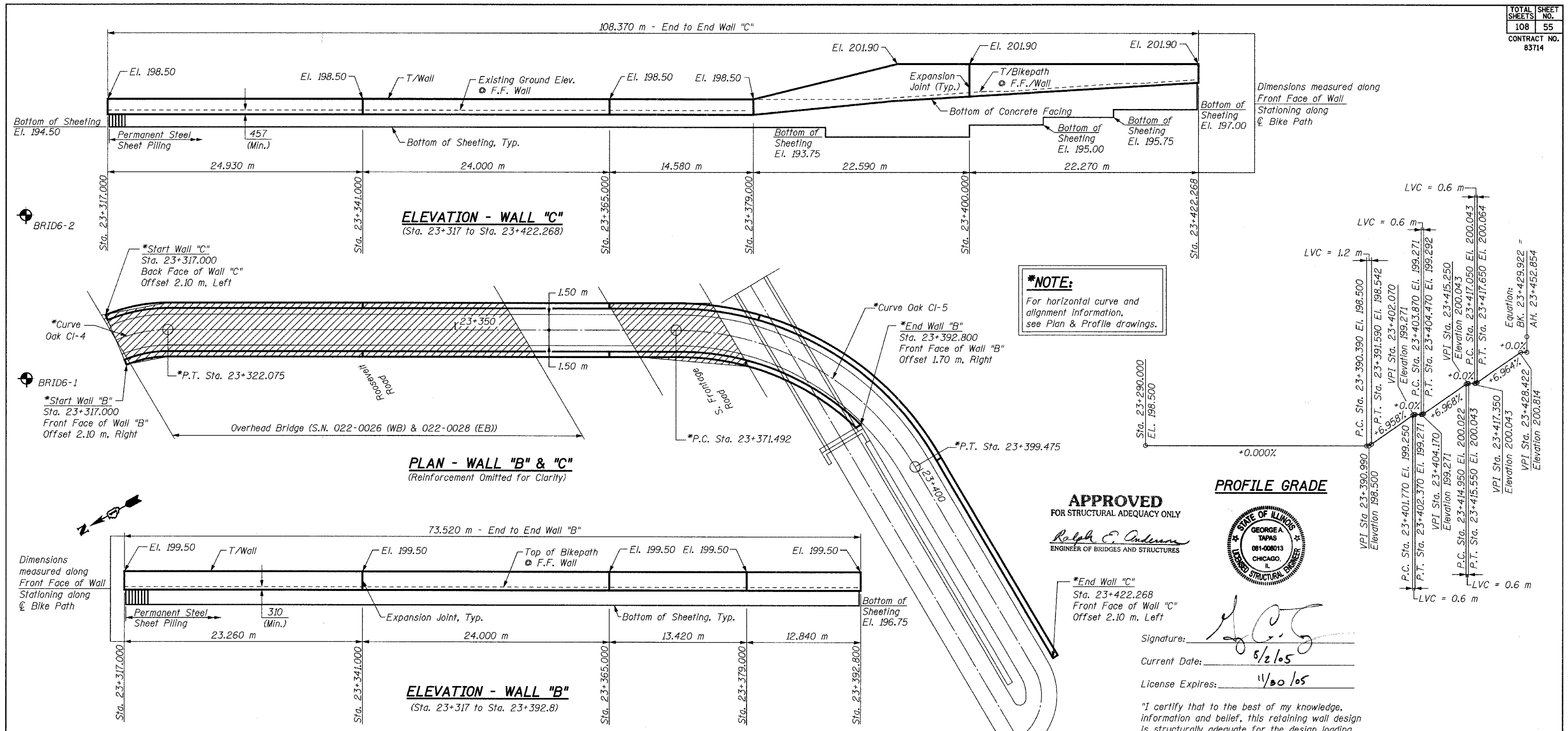

***NOTE:**
For horizontal curve and alignment information, see Plan & Profile drawings.

APPROVED
FOR STRUCTURAL ADEQUACY ONLY
Ralph E. Anderson
ENGINEER OF BRIDGES AND STRUCTURES



Signature: *[Signature]*
Current Date: 8/2/05
License Expires: 11/30/05

"I certify that to the best of my knowledge, information and belief, this retaining wall design is structurally adequate for the design loading shown on the plans. The design is an economical one for the style of structure and complies with the requirements of the current 'AASHTO Standard Specifications for Highway Bridges'."

GENERAL NOTES:

1. Reinforcement bars shall conform to the requirements of AASHTO M 31M, M 42M or M 53M Grade 400.
2. Plan dimensions and details relative to existing structure have been taken from existing plans and are subject to nominal construction variations. It shall be the Contractor's responsibility to verify such dimensions and details in the field and make necessary approved adjustments prior to construction or ordering of materials. Such variations shall not be cause for additional compensation for a change in the scope of work; however, the Contractor will be paid for the quantity actually furnished at the unit price bid for the work.
3. Steel sheet piling shall conform to the requirements of Section 1006.05 of the Standard Specifications.
4. If the Contractor chooses to alter the sheet piling design requirements shown on the plans for lesser design requirements, then full design submittal including plan details and sealed calculations will be required for review and acceptance by the Engineer.
5. All dimensions are in millimeters (mm) except as noted.
6. For Soil Boring Logs, see Special Provisions.
7. Any pre-excavation carried out for placement of the sheet piling shall not extend below the bottom of concrete facing elevation.

DESIGN SPECIFICATIONS

2002 AASHTO Standard Specifications for Highway Bridges, 17th Edition.
Illinois Department of Transportation Standard Specifications for Road & Bridge Construction, adopted January 1, 2002 and Supplemental Specifications and Recurring Special adopted January 1, 2004.

DESIGN LOADING

Equivalent Fluid Lateral Soil Pressure
6.3 kN/Cu. M

LEGEND

- Slope Wall Removal
- Soil Boring

DESIGN STRESSES

$f'_c = 24 \text{ MPa}$
 $f_y = 400 \text{ MPa (Reinf.)}$
 $f_y = 270 \text{ MPa (Sheet Piling)}$

TOTAL BILL OF MATERIAL

Item	Unit	Quantity
Concrete Structures	Cu. M	147.1
Reinforcement Bars, Epoxy Coated	kg	7580
Structure Excavation	Cu. M	170
Permanent Steel Sheet Piling	Sq. M	715
Pipe Handrail	Meter	110
Slopewall Removal	Sq. M	265

SHEET S20 of S33

REVISIONS	
NAME	DATE

1701 GOLF ROAD, SUITE 1000 TEL (847) 228-0707
ROLLING MEADOWS, IL 60008 FAX (847) 228-1115

VILLAGE OF OAKBROOK
SALT CREEK GREENWAY TRAIL
RET. WALL "B" AND "C"
GENERAL PLAN AND ELEVATION

DATE: 08/01/05
DESIGNED BY: MDS
DRAWN BY: MDS
CHECKED BY: GAT

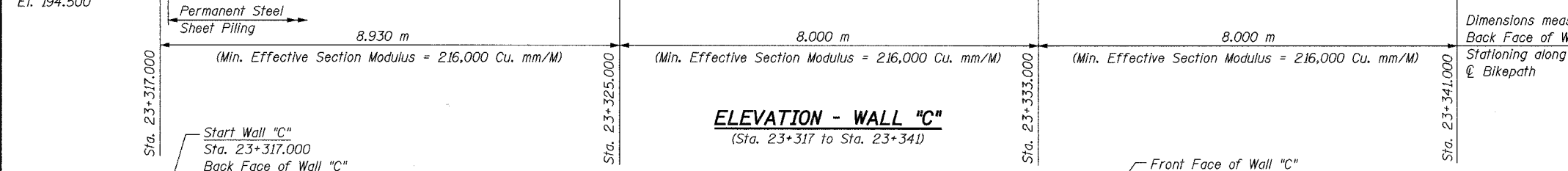
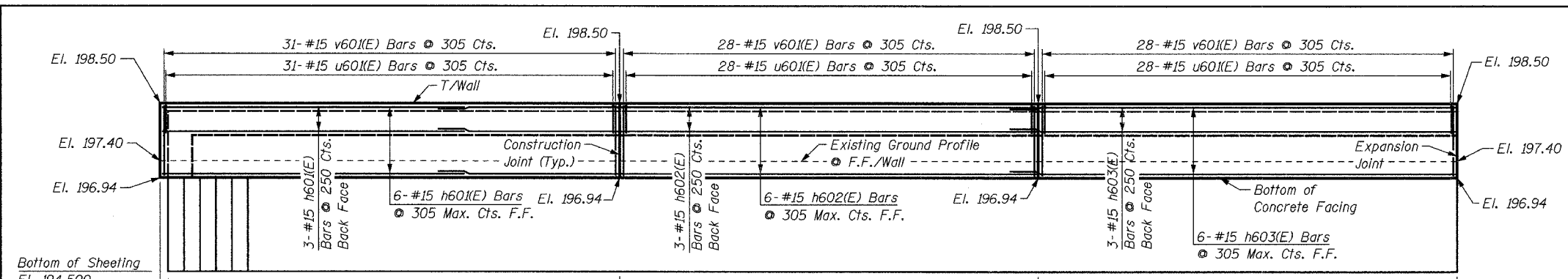

ELEVATION - WALL "C"
(Sta. 23+317 to Sta. 23+341)

PLAN - WALL "B" & "C"
(Sta. 23+317 to Sta. 23+341)
(Reinforcement Omitted for Clarity)

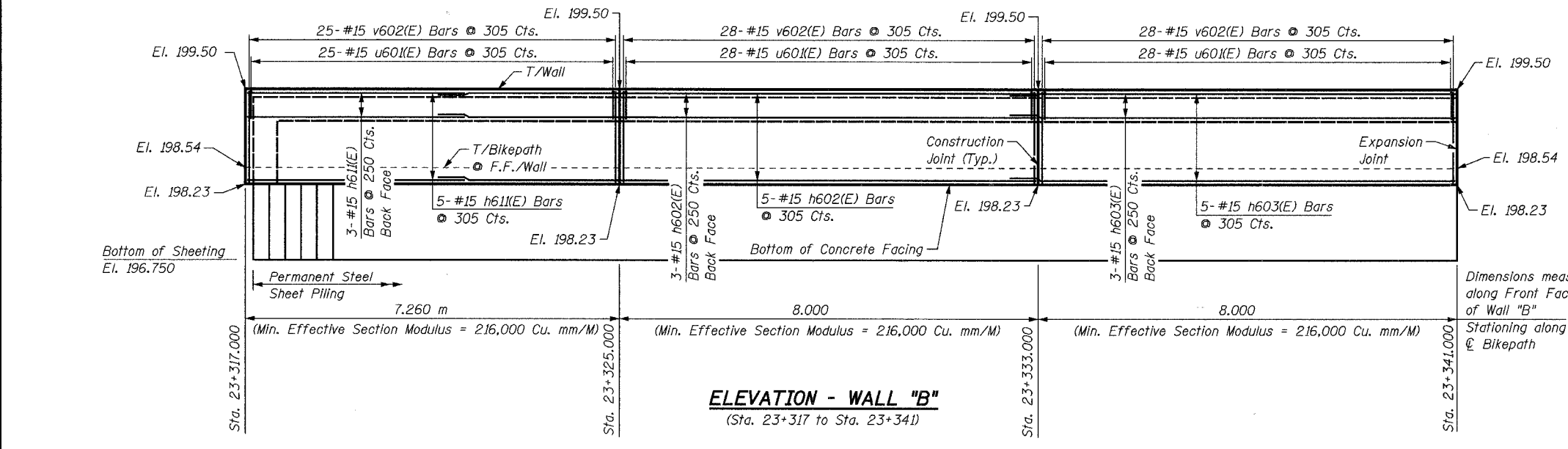
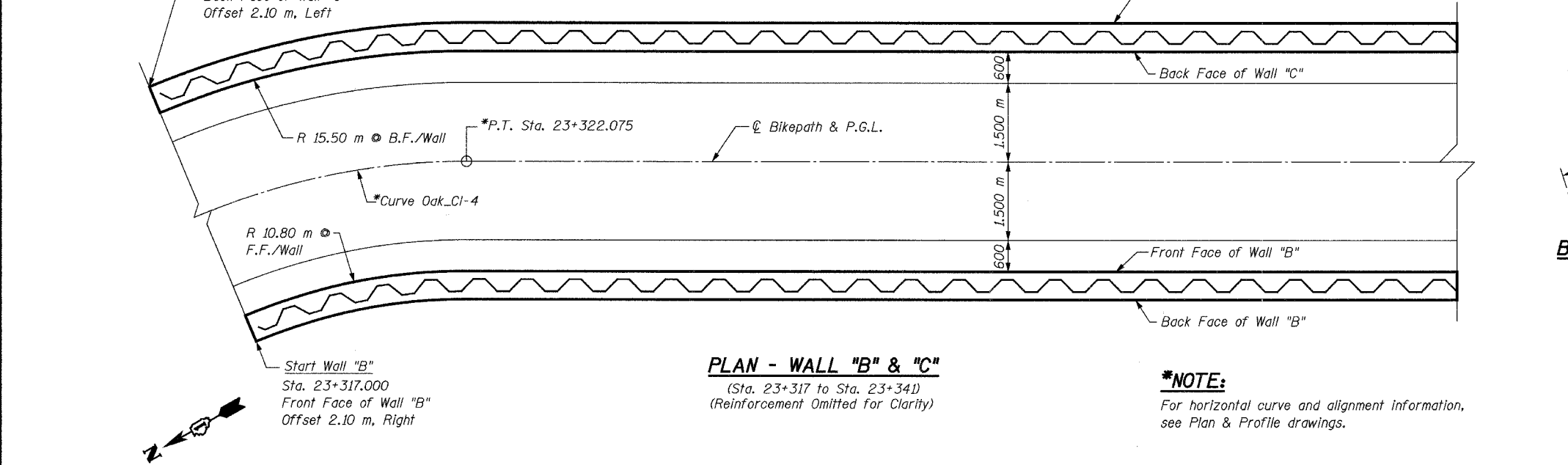

ELEVATION - WALL "B"
(Sta. 23+317 to Sta. 23+341)

BILL OF MATERIAL

Bar	No.	Size	Length	Shape
h60(E)	9	#15	5.96 m	—
h602(E)	17	#15	11.41 m	—
h603(E)	17	#15	8.48 m	—
h61(E)	8	#15	4.24 m	—
u60(E)	179	#15	1.45 m	⊏
v60(E)	89	#15	1.46 m	—
v602(E)	83	#15	1.17 m	—
Concrete Structures			Cu. M	35.6
Reinforcement Bars, Epoxy Coated			kg	1880
Structure Excavation			Cu. M	45
Permanent Steel Sheet Piling			Sq. M	157
Pipe Handrail			Meter	25

Bar	R	L
h60(E)	15.56 m	5.96 m
h61(E)	10.83 m	4.24 m

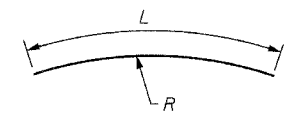

BAR h60(E) & h61(E)

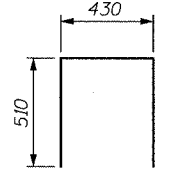

BAR u60(E)

NOTES:

- Fan h(E) bars for even distribution over face of wall.
- Cut v(E) bars as necessary in field to fit.
- Minimum lap for #15 bar = 480 mm.
- All exposed edges of concrete shall have a 20 mm chamfer unless shown otherwise.
- For minimum effective section modulus properties for sheet piling sections, refer to special provision for Permanent Steel Sheet Piling.
- Work this sheet with Sheets S20 thru S26.
- Bars designated (E) shall be epoxy coated.
- All dimensions are in millimeters (mm) unless otherwise noted.
- For Typical Section thru Wall, see Sheet S26.

REVISIONS		NAME	DATE
NO.	DESCRIPTION		

URS 1701 GOLF ROAD, SUITE 1000 TEL (847) 228-0707
ROLLING MEADOWS, IL 60008 FAX (847) 228-1115

VILLAGE OF OAKBROOK
SALT CREEK GREENWAY TRAIL
RET. WALL STA. 23+317 TO 23+341
PLAN & ELEVATION

DATE: 06/30/05
DESIGNED BY: MDS
DRAWN BY: MDS
CHECKED BY: GAT

BILL OF MATERIAL

Bar	No.	Size	Length	Shape
h603(E)	34	#15	8.48 m	—
h604(E)	17	#15	7.90 m	—
u60(E)	168	#15	1.45 m	□
v60(E)	84	#15	1.46 m	—
v602(E)	84	#15	1.17 m	—
Concrete Structures		Cu. M	35.6	
Reinforcement Bars, Epoxy Coated		kg	1840	
Structure Excavation		Cu. M	45	
Permanent Steel Sheet Piling		Sq. M	155	
Pipe Handrail		Meter	24	

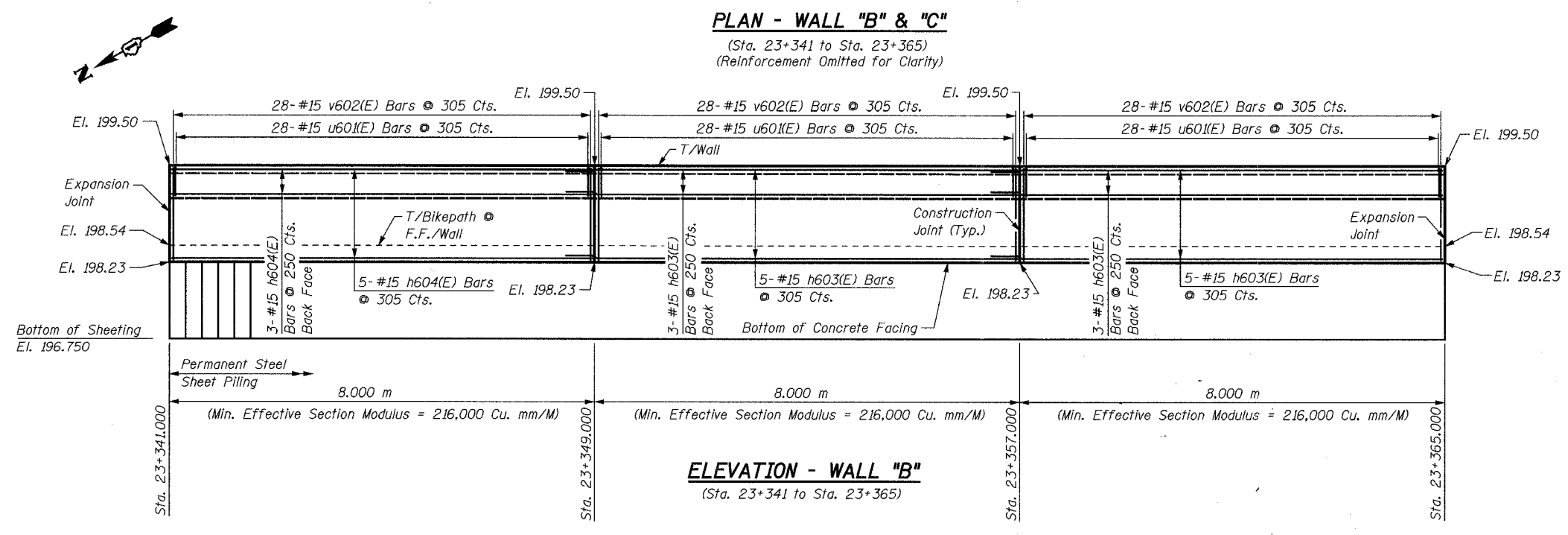
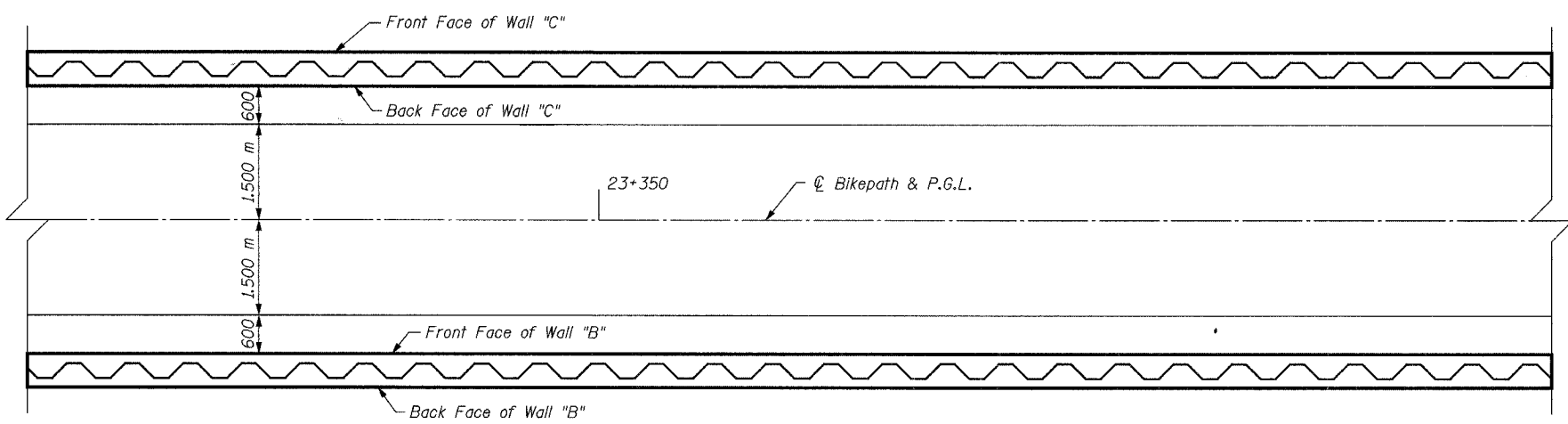
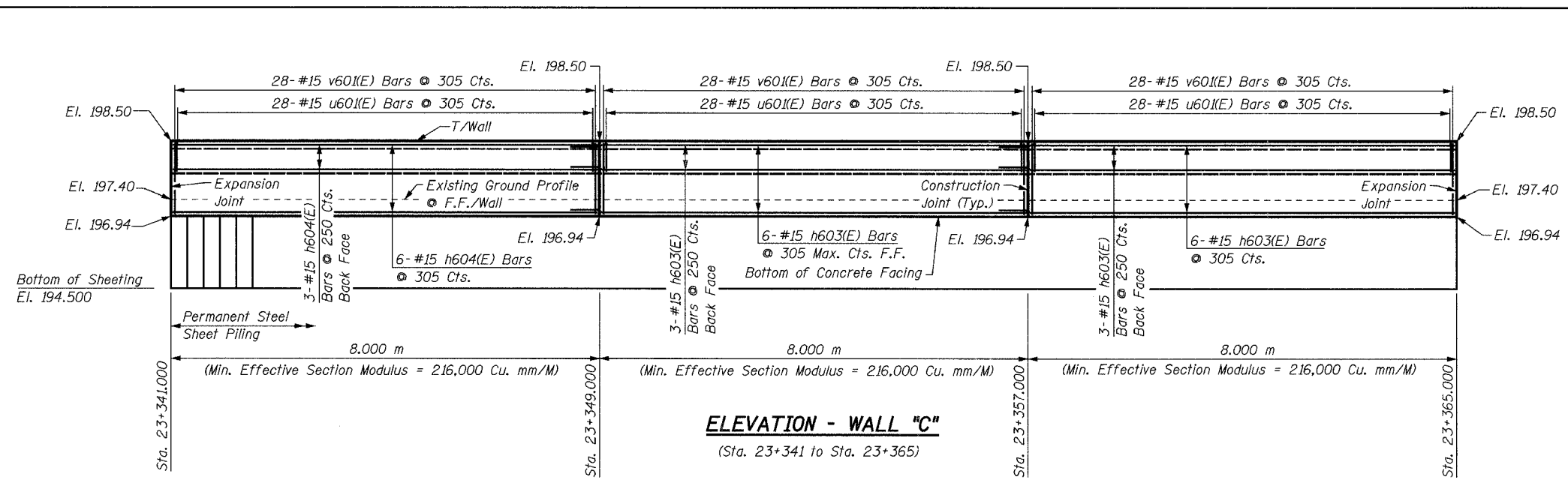
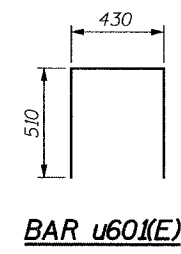

NOTES:
See Sheet S21 for Notes.

SHEET S22 of S33

REVISIONS		NAME	DATE

URS 1701 GOLF ROAD, SUITE 1000 TEL (847) 228-0707
ROLLING MEADOWS, IL 60008 FAX (847) 228-1115

VILLAGE OF OAKBROOK
SALT CREEK GREENWAY TRAIL
RET. WALL STA. 23+341 TO 23+365
PLAN & ELEVATION

DATE: 06/30/05
DESIGNED BY: MDS
DRAWN BY: MDS
CHECKED BY: GAT

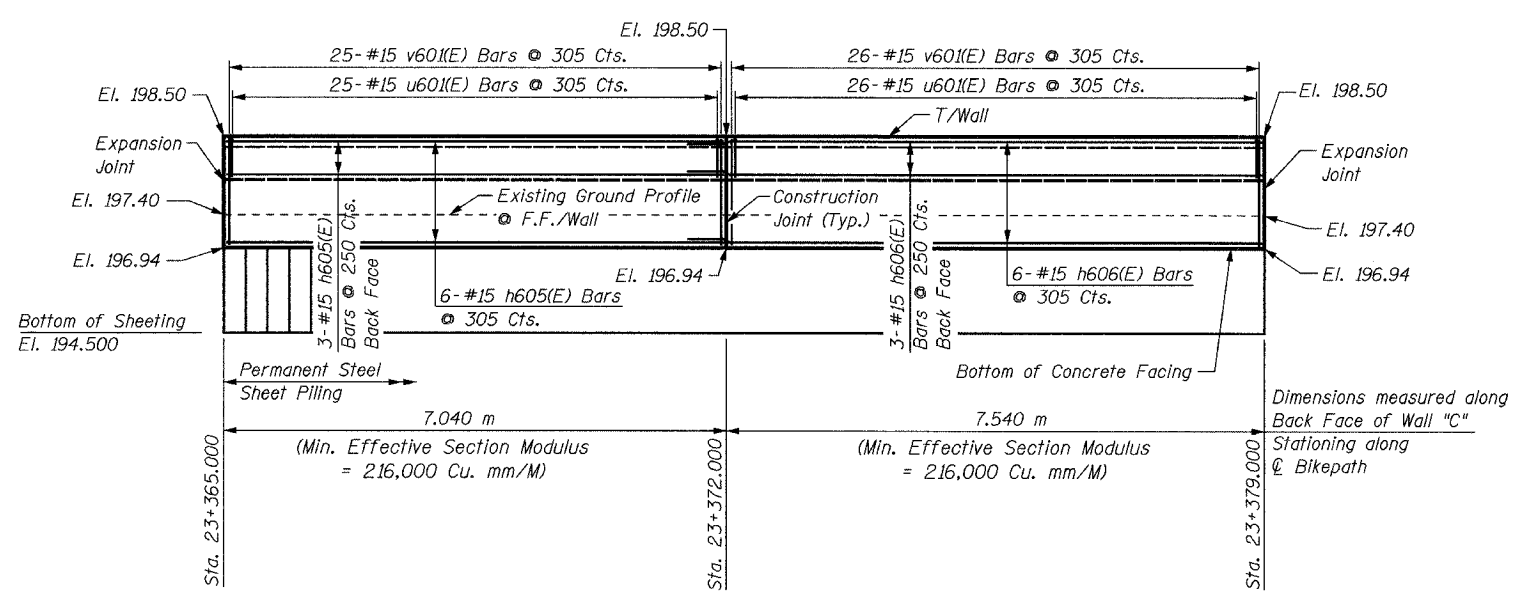

ELEVATION - WALL "C"
(Sta. 23+365 to Sta. 23+379)

Bar	R	L
h606(E)	29.56 m	8.02 m
h607(E)	25.15 m	7.00 m

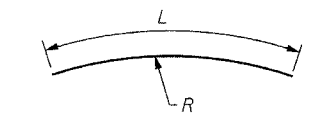

BAR h606(E) & h607(E)

BILL OF MATERIAL

Bar	No.	Size	Length	Shape
h605(E)	17	#15	6.88 m	—
h606(E)	9	#15	8.02 m	—
h607(E)	8	#15	7.00 m	—
u60(E)	98	#15	1.45 m	⊏
v60(E)	51	#15	1.46 m	—
v602(E)	47	#15	1.17 m	—
Concrete Structures		Cu. M	20.7	
Reinforcement Bars, Epoxy Coated		kg	1070	
Structure Excavation		Cu. M	26	
Permanent Steel Sheet Piling		Sq. M	91	
Pipe Handrail		Meter	15	

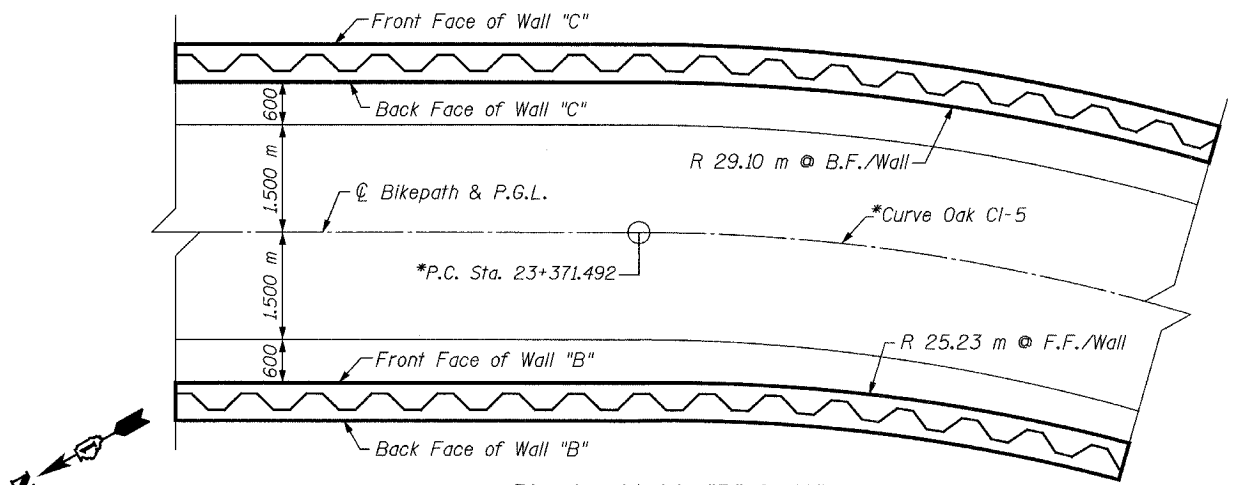

PLAN - WALL "B" & "C"
(Sta. 23+365 to Sta. 23+379)
(Reinforcement Omitted for Clarity)

***NOTE:**
For horizontal curve and alignment information, see Plan & Profile drawings.

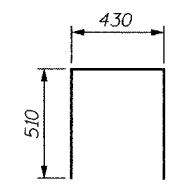

BAR u60(E)

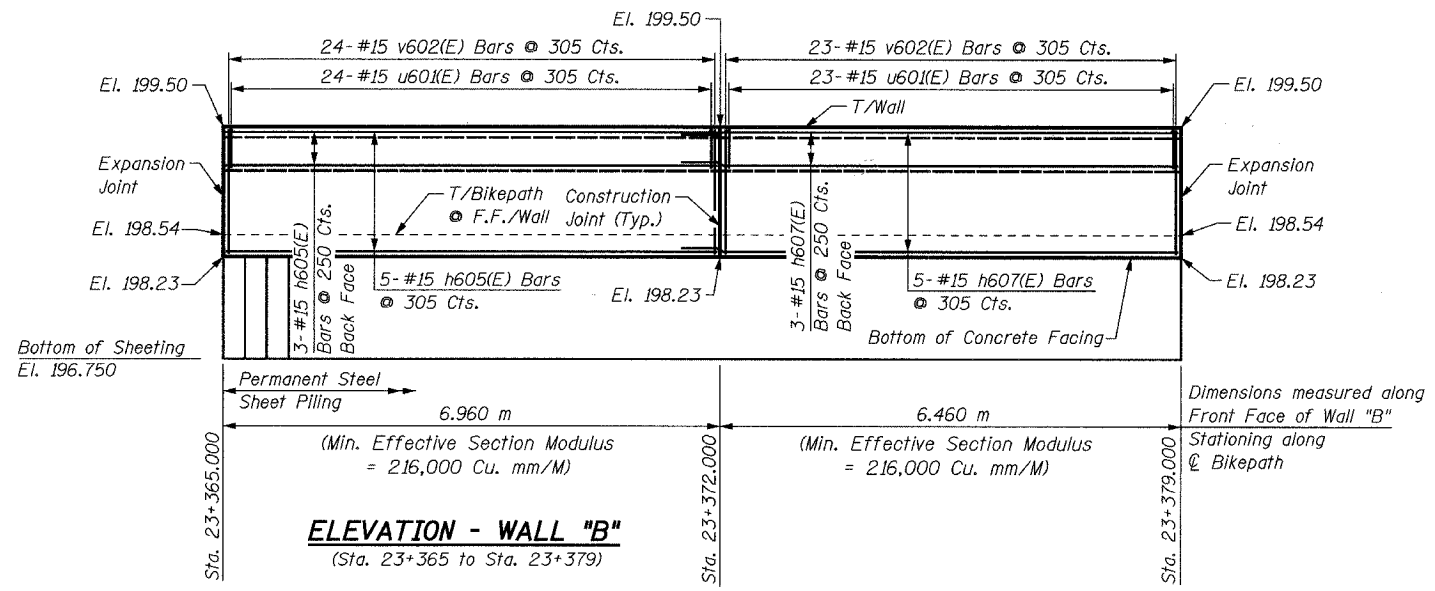

ELEVATION - WALL "B"
(Sta. 23+365 to Sta. 23+379)

NOTES:
See Sheet S21 for Notes.

SHEET S23 of S33

REVISIONS		NAME	DATE
NO.	DESCRIPTION		

URS

1701 GOLF ROAD, SUITE 1000
ROLLING MEADOWS, IL 60008

TEL (847) 228-0707
FAX (847) 228-1115

VILLAGE OF OAKBROOK

SALT CREEK GREENWAY TRAIL

RET. WALL STA. 23+365 TO 23+379

PLAN & ELEVATION

DATE: 06/30/05
DESIGNED BY: MDS

DRAWN BY: MDS
CHECKED BY: GAT

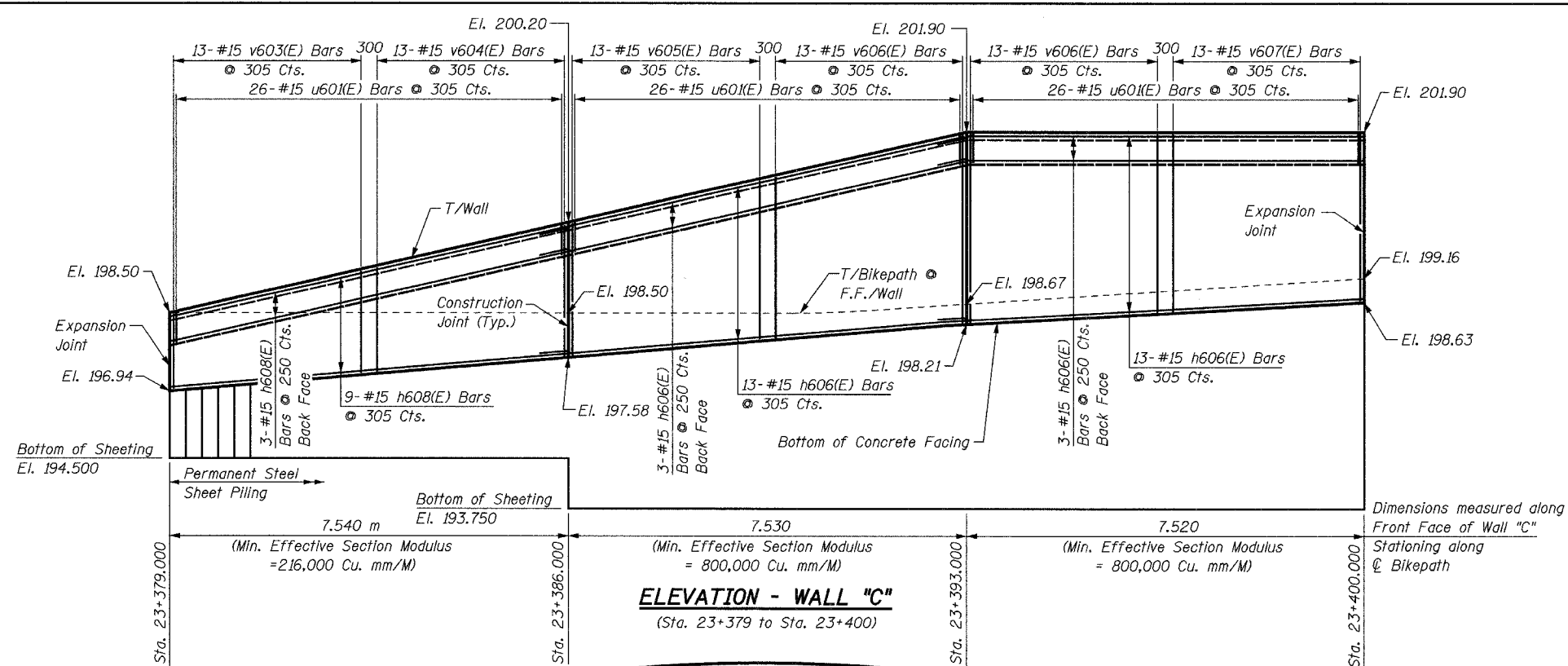

ELEVATION - WALL "C"
(Sta. 23+379 to Sta. 23+400)

BILL OF MATERIAL

Bar	No.	Size	Length	Shape
h606(E)	32	#15	8.02 m	—
h608(E)	12	#15	7.44 m	—
h609(E)	8	#15	6.40 m	—
h612(E)	8	#15	6.83 m	—
u601(E)	128	#15	1.45 m	⊏
v602(E)	45	#15	1.17 m	—
v603(E)	13	#15	1.99 m	—
v604(E)	13	#15	2.52 m	—
v605(E)	13	#15	3.05 m	—
v606(E)	26	#15	3.59 m	—
v607(E)	13	#15	3.38 m	—
Concrete Structures			Cu. M	33.7
Reinforcement Bars, Epoxy Coated			kg	1670
Structure Excavation			Cu. M	33
Permanent Steel Sheet Piling			Sq. M	183
Pipe Handrail			Meter	23

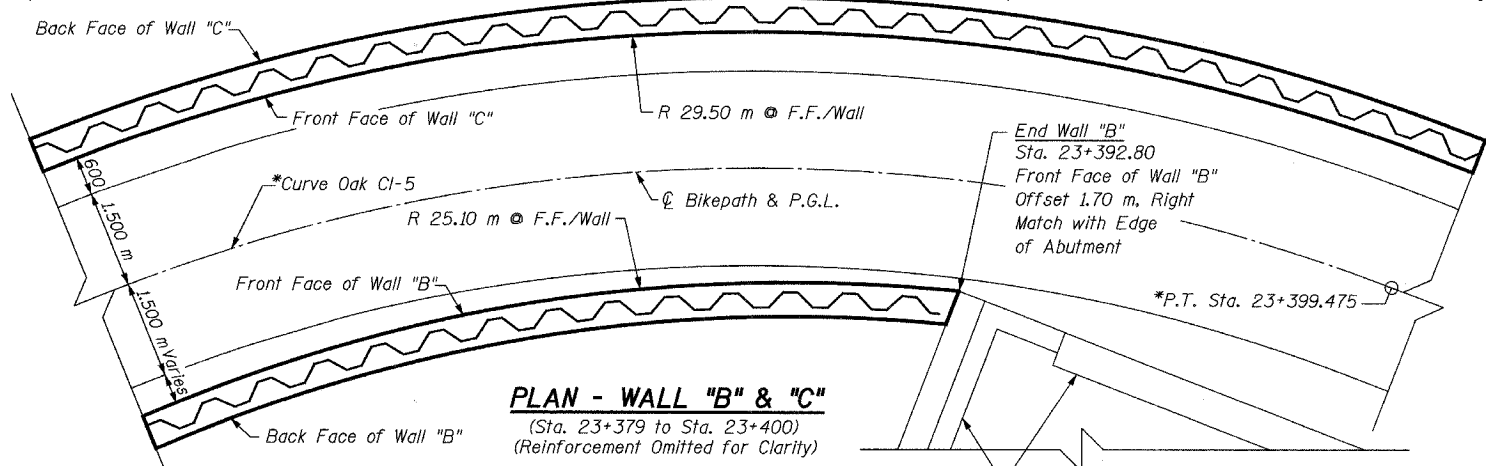

PLAN - WALL "B" & "C"
(Sta. 23+379 to Sta. 23+400)
(Reinforcement Omitted for Clarity)

***NOTE:**
For horizontal curve and alignment information, see Plan & Profile drawings.

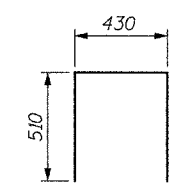

BAR u601(E)

Bar	R	L
h606(E)	29.56 m	8.02 m
h608(E)	29.56 m	7.44 m
h609(E)	25.15 m	6.40 m
h612(E)	25.15 m	6.83 m

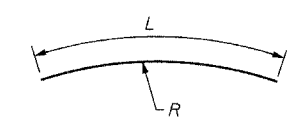

BAR h606(E), h608(E), h609(E) & h612(E)

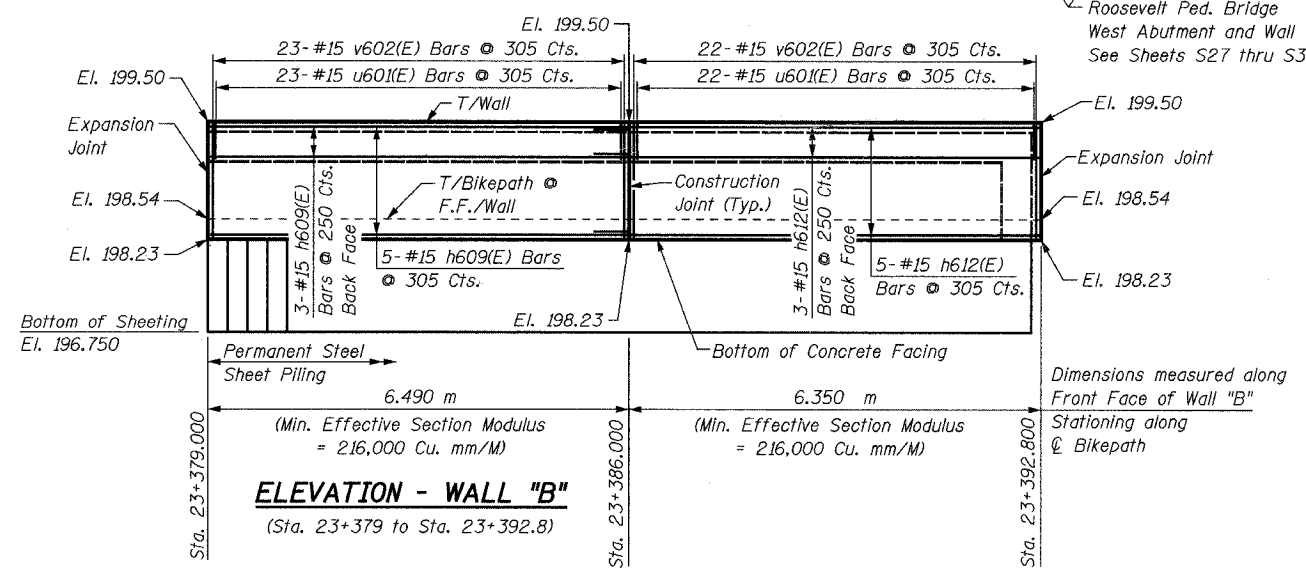

ELEVATION - WALL "B"
(Sta. 23+379 to Sta. 23+392.8)

NOTES:
See Sheet S21 for Notes.

SHEET S24 of S33

REVISIONS		NAME	DATE
NO.	DESCRIPTION		

URS 1701 GOLF ROAD, SUITE 1000 TEL (847) 228-0707
ROLLING MEADOWS, IL 60008 FAX (847) 228-1115

VILLAGE OF OAKBROOK
SALT CREEK GREENWAY TRAIL
RET. WALL STA. 23+379 TO 23+400
PLAN & ELEVATION

DATE: 06/30/05
DESIGNED BY: MDS
DRAWN BY: MDS
CHECKED BY: GAT

BILL OF MATERIAL

Bar	No.	Size	Length	Shape
h605(E)	15	#15	6.88 m	—
h610(E)	14	#15	7.48 m	—
h613(E)	12	#15	8.75 m	—
u601(E)	85	#15	1.45 m	□
v604(E)	12	#15	2.52 m	—
v608(E)	12	#15	3.17 m	—
v609(E)	12	#15	2.97 m	—
v610(E)	12	#15	2.76 m	—
v611(E)	14	#15	2.34 m	—
v612(E)	14	#15	2.09 m	—
Concrete Structures		Cu. M	21.5	
Reinforcement Bars, Epoxy Coated		kg	1120	
Structure Excavation		Cu. M	20.6	
Permanent Steel Sheet Piling		Sq. M	116	
Pipe Handrail		Meter	23	

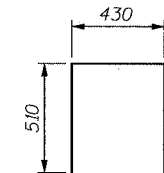

BAR u601(E)

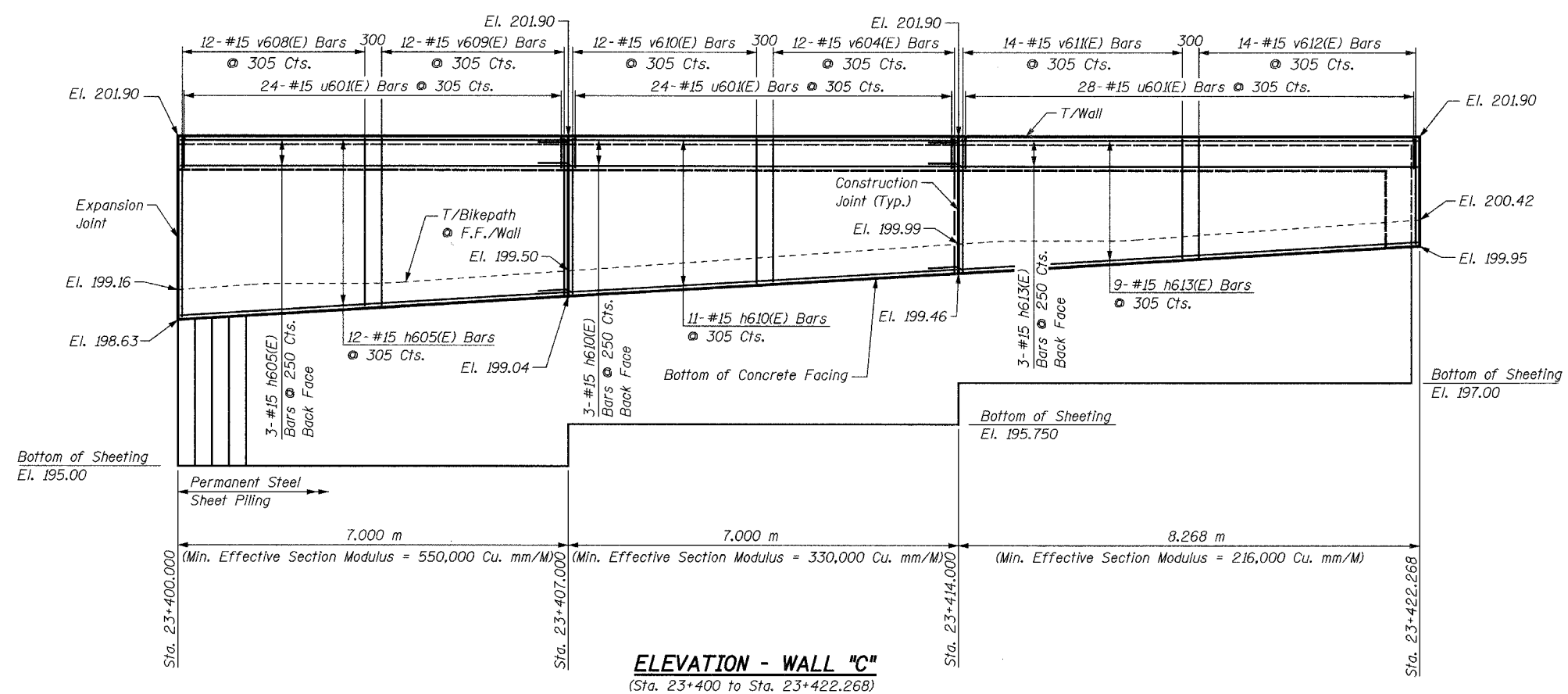

ELEVATION - WALL "C"
(Sta. 23+400 to Sta. 23+422.268)

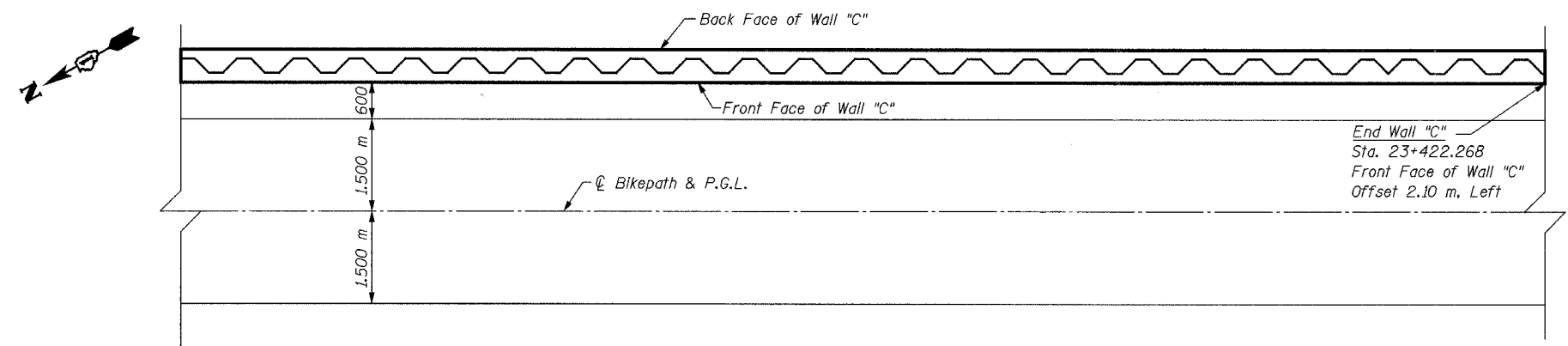

PLAN - WALL "C"
(Sta. 23+400 to Sta. 23+422.268)
(Reinforcement Omitted for Clarity)

NOTES:
See Sheet S21 for Notes.

SHEET S25 of S33

REVISIONS		NAME	DATE	1701 GOLF ROAD, SUITE 1000 ROLLING MEADOWS, IL 60008 TEL (847) 228-0707 FAX (847) 228-1115
NO.	DESCRIPTION			
				VILLAGE OF OAKBROOK SALT CREEK GREENWAY TRAIL RET. WALL STA. 23+400 TO 23+422.27 PLAN & ELEVATION
DATE: 06/30/05		DESIGNED BY: MDS		DRAWN BY: MDS CHECKED BY: GAT

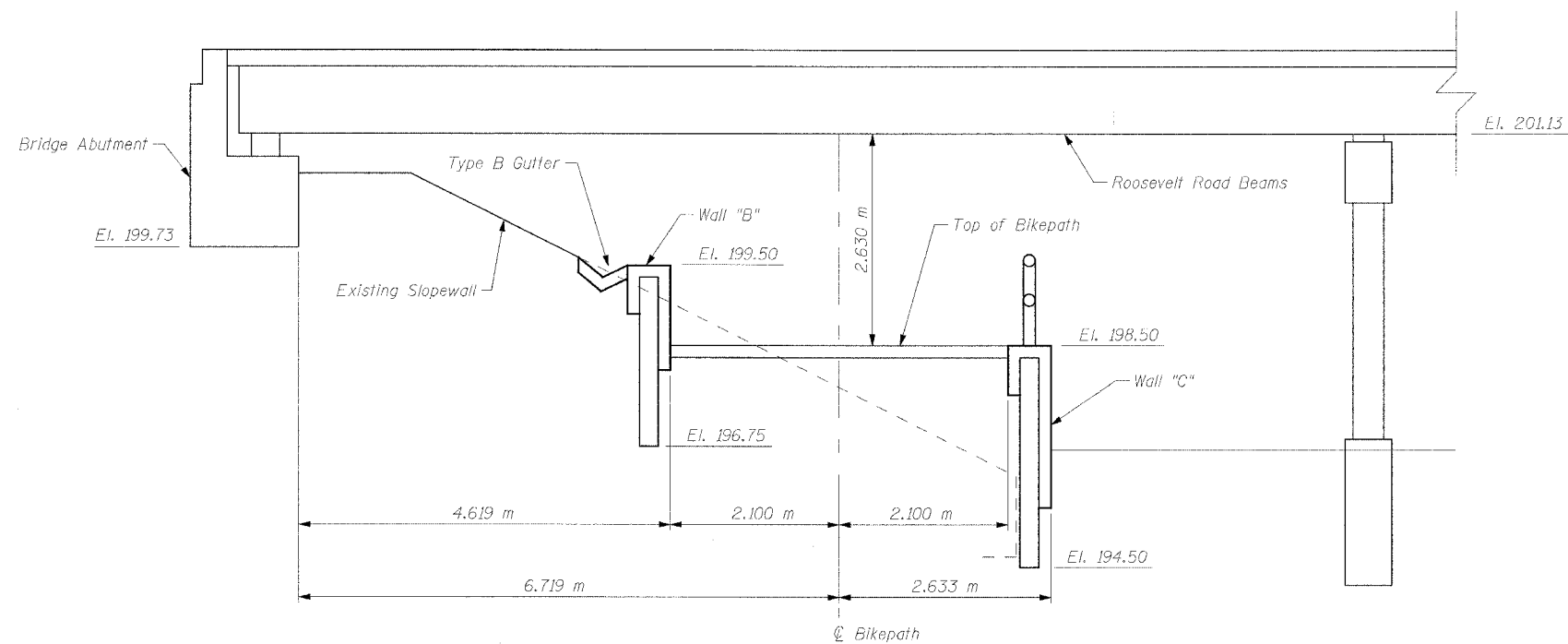

CROSS SECTION UNDER ROOSEVELT ROAD
(Sta. 23+318.00)

ALTERNATIVE SHEET PILING INSTALLATION:

IN LOCATIONS WHERE THE HEADROOM IS FOUND TO BE LIMITED IN PREVENTING PROPER THREADING OF THE ADJACENT SHEET PILING SECTION INTERLOCKS, THE CONTRACTOR IS PERMITTED TO SUBMIT FOR APPROVAL AN ALTERNATIVE INSTALLATION METHOD PRIOR TO CONSTRUCTION. EXAMPLES OF ACCEPTABLE METHOD OF INSTALLATION INCLUDE WELDING THE PILING, INSTALLING MULTIPLE SHEETS BOLTED TOGETHER, OR SPECIAL DRIVING EQUIPMENT. THE COST OF THE WORK REQUIRED TO IMPLEMENT AND CONDUCT THE APPROVED METHOD IS INCLUDED WITH "PERMANENT STEEL SHEET PILING".

SHEET S26A of S33

REVISIONS		 1701 COLT ROAD, SUITE 1000 TFL (847) 228-0707 ROLLING MEADOWS, IL 60008 FAX (847) 228-1115
NAME	DATE	
		VILLAGE OF ADDISON SALT CREEK GREENWAY TRAIL TYPICAL CROSS SECTION UNDER ROOSEVELT ROAD
		DATE: 05/10/06 DRAWN BY: MDS DESIGNED BY: MDS CHECKED BY: GAT

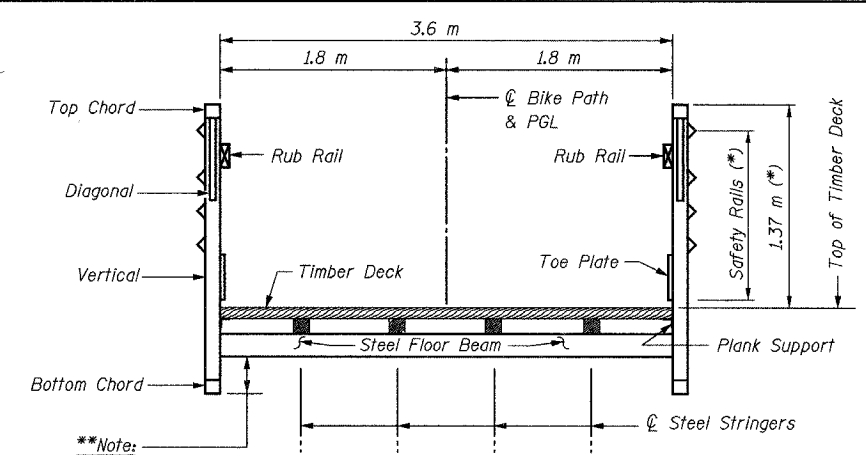
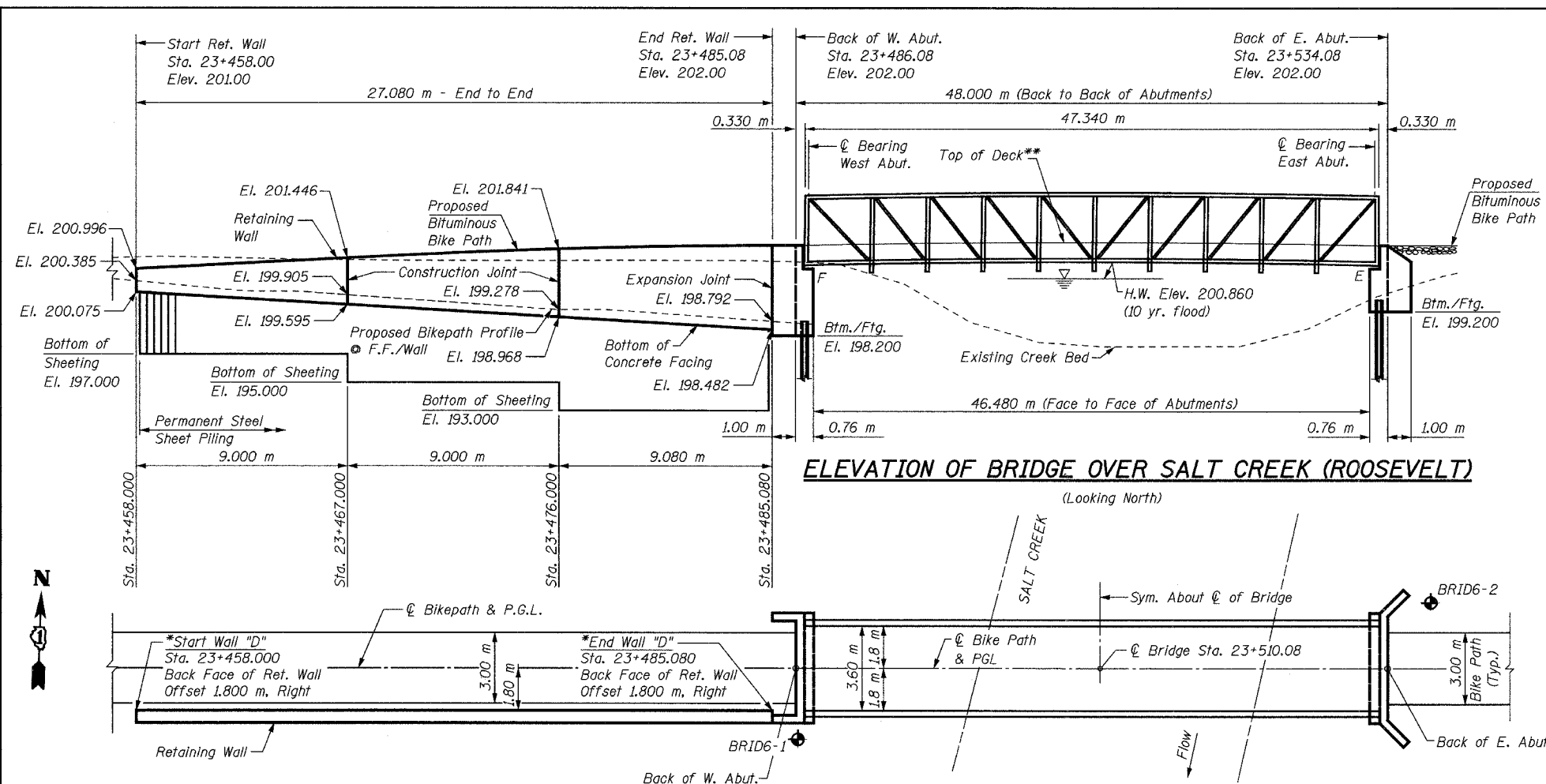

TYPICAL CROSS SECTION

****Note:**
Bridge Fabricator to adjust depth so that bottom chord elevation is above Frontage Road low beam elevation

(*) Note:
If the top of the chord is greater than 1.37 m above the top of deck, a second rub rail shall be placed at 1.37 m above top of deck.

ELEVATION OF BRIDGE OVER SALT CREEK (ROOSEVELT)

(Looking North)

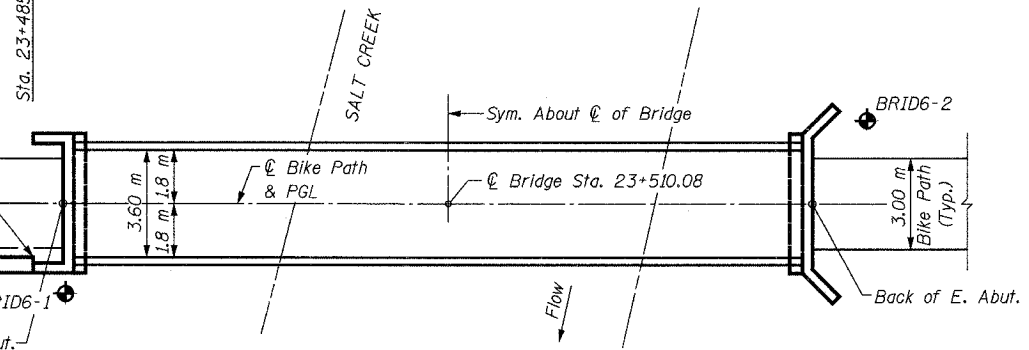

PLAN

***NOTE:**
For horizontal curve and alignment information, see Plan & Profile drawings.

DESIGN SPECIFICATIONS

2002 AASHTO Standard Specifications for Highway Bridges, 17th Edition.
Illinois Department of Transportation Standard Specifications for Road & Bridge Construction, adopted January 1, 2002 and Supplemental Specifications and Recurring Special Provisions adopted January 1, 2004.
AASHTO Guide Specifications for the Design of Pedestrian Bridges, 1997 Edition.

SEISMIC DATA

Seismic Performance Category (SPC) = A
Bedrock Acceleration Coefficient (A) = 0.04g
Site Coefficient (S) = 1.0

LOADING

Live Loading + Impact
4100 N/Sq. M Live Load
(May be adjusted for influence area)
50kN Vehicle Load (MS-5 Truck)
Equivalent Fluid Lateral Soil Pressure
6.3 kN/Cu. M

DESIGN STRESSES

f'c = 24 Mpa
fy = 400 Mpa (Reinf.)
fy = 265 Mpa (Sheet Piling)

LEGEND

Soil Boring

CLASSIFICATION

Pedestrian/Bicycle Bridge

TOTAL BILL OF MATERIAL

Item	Unit	Total
Structure Excavation	Cu. M	68
Concrete Structures	Cu. M	49.7
Reinforcement Bars, Epoxy Coated	kg	2810
Pedestrian Bridge Superstructure	Sq. M	173
Furnishing Steel Piles HP310x79	Meter	34
Furnishing Steel Piles HP310x94	Meter	51
Driving Steel Piles	Meter	85
Test Pile Steel HP310x79	Each	1
Metal Shoes	Each	5
Permanent Steel Sheet Piling	Sq. M	142
Pipe Handrail	Meter	27

GENERAL NOTES:

- The superstructure, including all truss members, railings, toe plates, bearings, wood deck, and all attachments on superstructure, shall be designed and detailed by the Contractor.
- Reinforcement bars shall conform to the requirements of AASHTO 31M, M 42M, or M 53M Grade 400.
- Bearing seat surfaces shall be constructed or adjusted to the designated elevations within a tolerance of 3 mm. Adjustment shall be made either by grinding the surface or by shimming the bearing. Two 3 mm adjusting shims, of the dimensions of the bottom bearing plate, shall be provided for each bearing in addition to all other plates or shims.
- The Contractor shall drive one (1) test pile in the permanent location at the West Abutment (center pile of group) as directed by the Engineer before ordering the remainder of the piles.
- The profile of the structure shall be as shown, and as specified in the Special Provisions for camber.
- The Contractor shall verify the final location of anchor bolts with the Bridge Manufacturer prior to construction and placement.
- Steel sheet piling shall conform to the requirements of Section 1006.05 of the Standard Specifications.
- If the Contractor chooses to alter the sheet piling design requirements shown on the plans for lesser design requirements, then full design submittal including plan details and sealed calculations will be required for review and acceptance by the Engineer.
- All dimensions are in millimeters (mm) except as noted.
- For Soil Boring Logs see Special Provisions.
- Any pre-excavation carried out for placement of the sheet piling shall not extend below the bottom of concrete facing elevation.

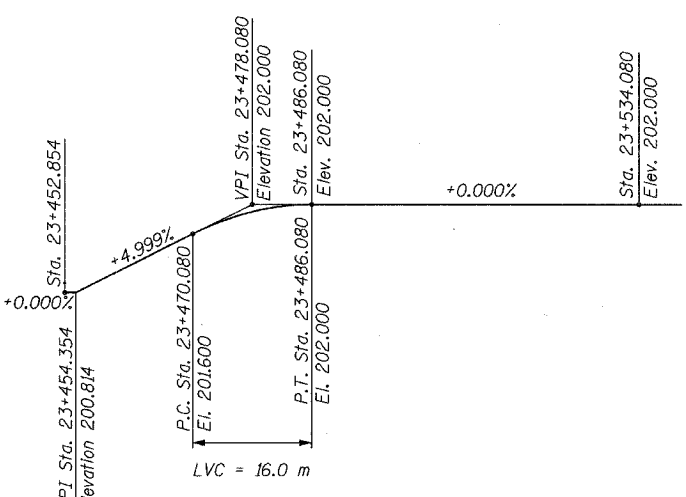

PROFILE GRADE

Signature: *[Signature]*
Current Date: 7/21/05
License Expires: 11/30/06

"I certify that to the best of my knowledge, information and belief, this bridge design is structurally adequate for the design loading shown on the plans. The design is an economical one for the style of structure and complies with the requirements of the current 'AASHTO Standard Specifications for Highway Bridges'."



REVISIONS		NAME	DATE
NO.	DESCRIPTION		

URS 1701 GOLF ROAD, SUITE 1000 TEL (847) 228-0707
ROLLING MEADOWS, IL 60008 FAX (847) 228-1115

VILLAGE OF OAKBROOK
SALT CREEK GREENWAY TRAIL
BRIDGE & RET. WALL, STA. 23+508.08
GENERAL PLAN AND ELEVATION

DATE: 06/30/05
DESIGNED BY: MDS
DRAWN BY: MDS
CHECKED BY: GAT

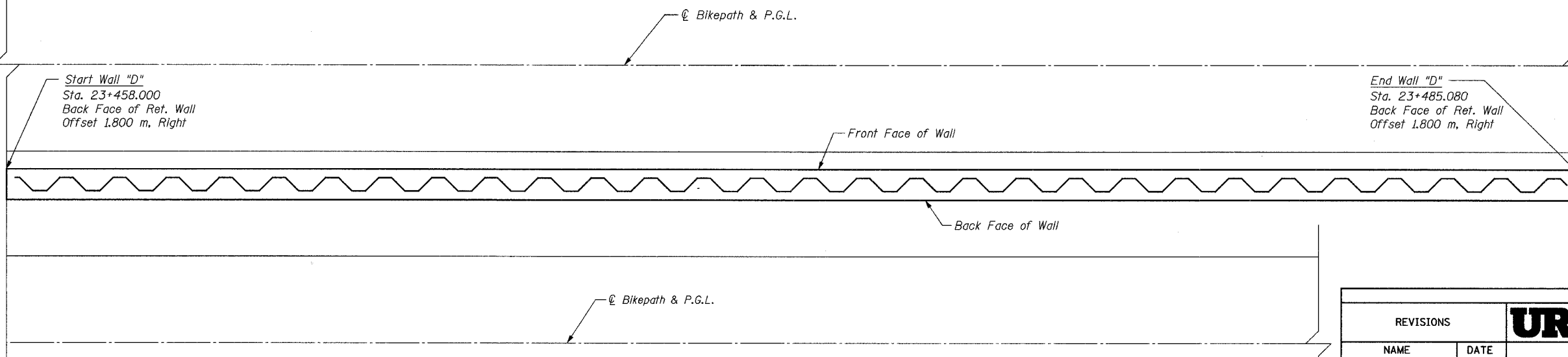
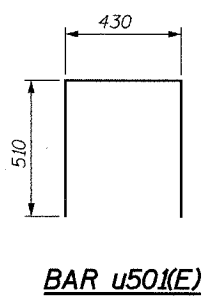
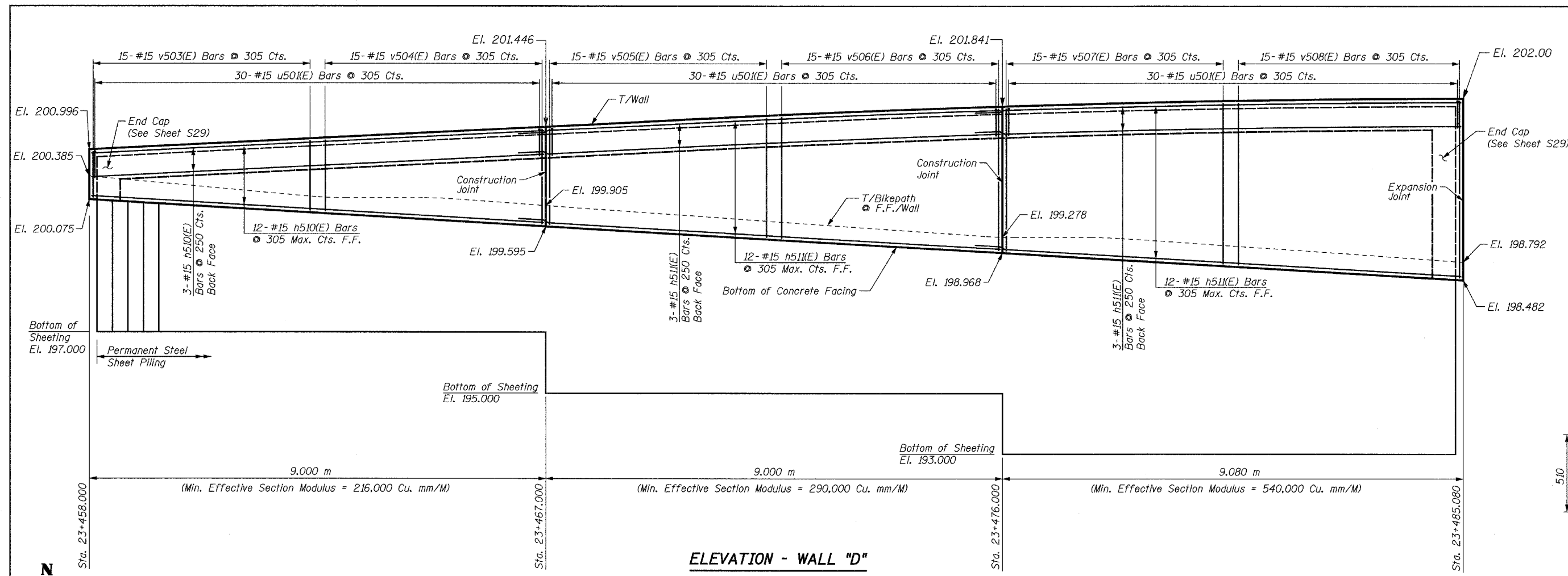

NOTES:
 For Notes and Bill of Material, see Sheet S29.
 Work this sheet with Sheet S29.

SHEET S28 of S33

REVISIONS		NAME	DATE
NO.	DESCRIPTION		

URS 1701 GOLF ROAD, SUITE 1000 TEL (847) 228-0707
 ROLLING MEADOWS, IL 60008 FAX (847) 228-1115

VILLAGE OF OAKBROOK
 SALT CREEK GREENWAY TRAIL
 WALL "D", STA. 23+458 TO
 STA. 23+485.08, PLAN & ELEVATION

DATE: 06/30/05
 DESIGNED BY: MDS
 DRAWN BY: MDS
 CHECKED BY: GAT

BILL OF MATERIAL

Bar	No.	Size	Length	Shape
h510(E)	15	#15	8.90 m	—
h511(E)	30	#15	9.64 m	—
u501(E)	114	#15	1.45 m	□
v503(E)	17	#15	1.28 m	—
v504(E)	15	#15	1.75 m	—
v505(E)	15	#15	2.26 m	—
v506(E)	15	#15	2.77 m	—
v507(E)	15	#15	3.09 m	—
v508(E)	17	#15	3.41 m	—
Concrete Structures			Cu. M	20.8
Reinforcement Bars, Epoxy Coated			kg	1,290
Structure Excavation			Cu. M	15.2
Permanent Steel Sheet Piling			Sq. M	175
Pipe Handrail			Meter	27

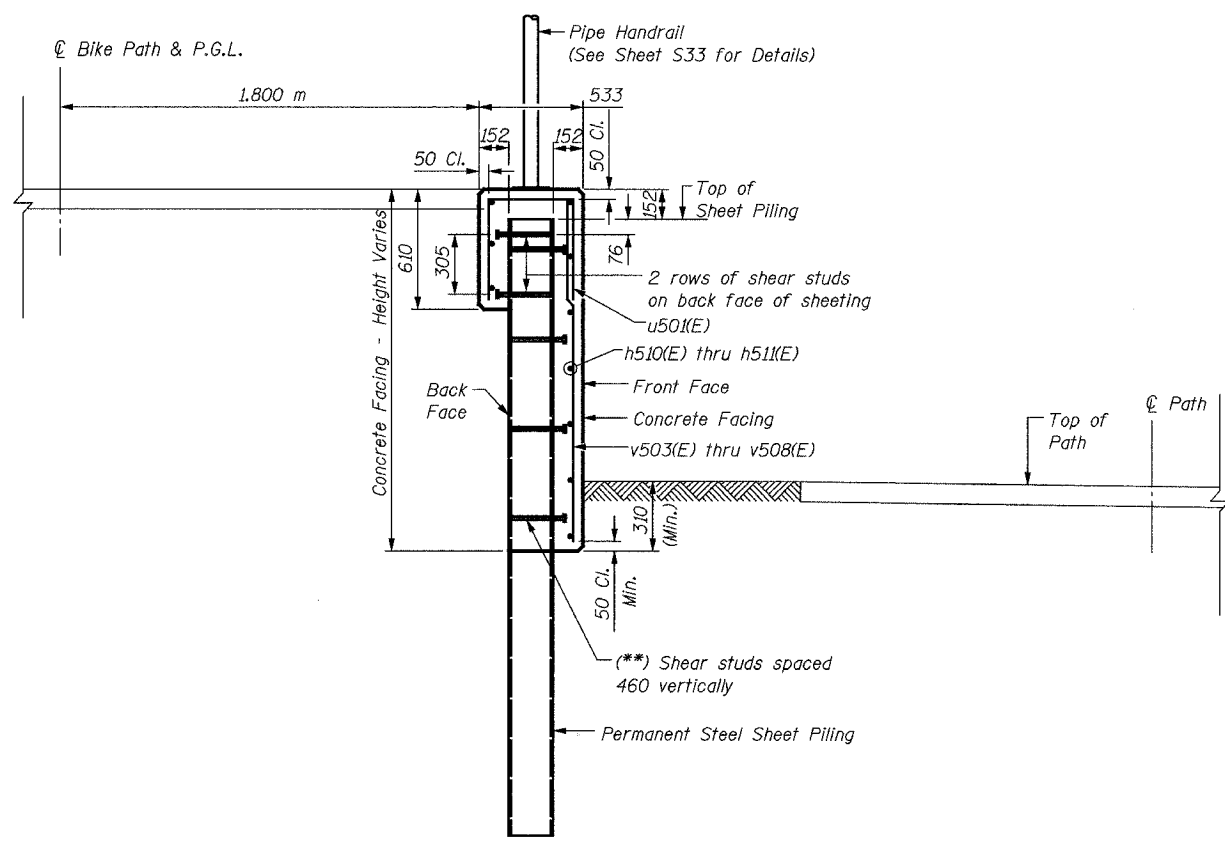

SECTION THRU WALL "D"
(Section Sta. 23+458 to Sta. 23+485.08)

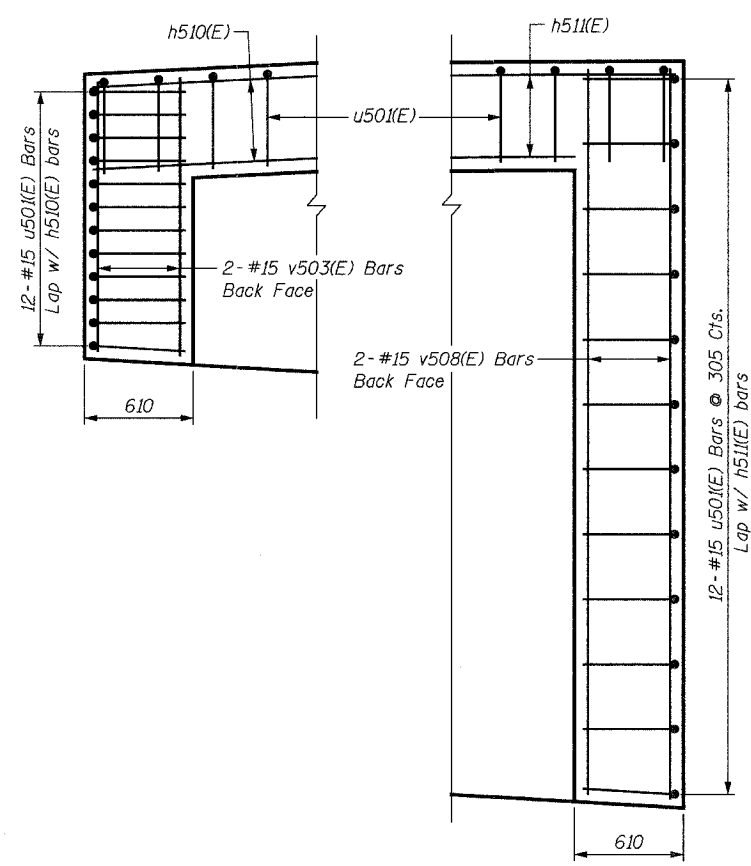

WEST END EAST END
END CAP WALL DETAILS - WALL "D"

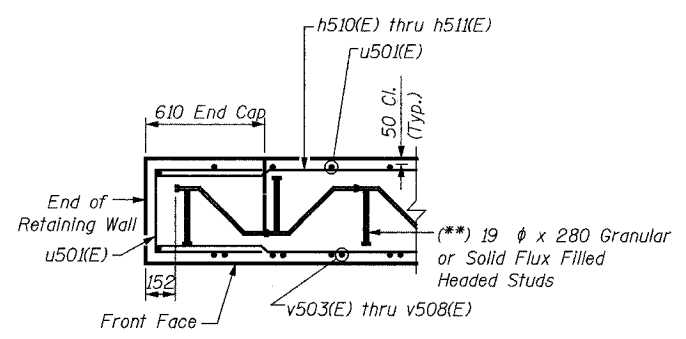

SECTION THRU CAP

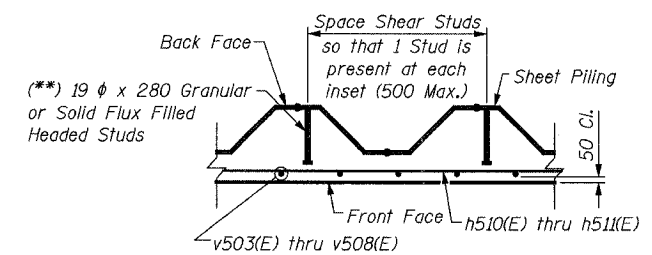

TYPICAL SECTION THRU WALL

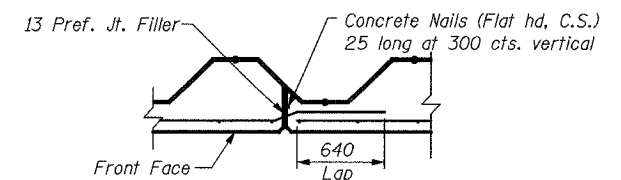

CONSTRUCTION JOINT DETAIL

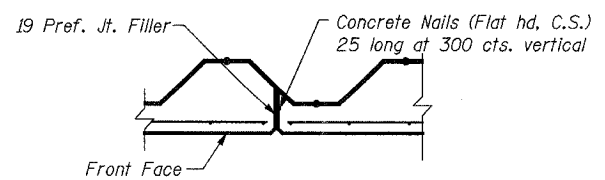

EXPANSION JOINT DETAIL

NOTES:

- Fan h(E) bars for even distribution over face of wall.
- Cut v(E) bars as necessary in field to fit.
- Minimum lap for #15 bar = 640 mm.
- All exposed edges of concrete shall have a 20 mm chamfer unless shown otherwise.
- For minimum effective section modulus properties for sheet piling sections, refer to special provision for Permanent Steel Sheet Piling.
- Work this sheet with Sheet S28.
- Bars designated (E) shall be epoxy coated.
- All dimensions are in millimeters (mm) unless otherwise noted.
- For Plan and Elevation of Wall "D", see Sheet S28.

() NOTE:**

Shear Studs shall be 19 dia. x 208 Granular or Solid Flux Filled Headed Studs conforming to 505.08 (m) of the Standard Specifications, automatically end welded in the field to Sheet Piling. The cost of the studs is included in the cost of PERMANENT STEEL SHEET PILING.

REVISIONS		NAME	DATE

URS 1701 GOLF ROAD, SUITE 1000 TEL (847) 228-0707
ROLLING MEADOWS, IL 60008 FAX (847) 228-1115

VILLAGE OF OAKBROOK
SALT CREEK GREENWAY TRAIL
RETAINING WALL "D"
DETAILS

DATE: 06/30/05
DESIGNED BY: MDS
DRAWN BY: MDS
CHECKED BY: GAT

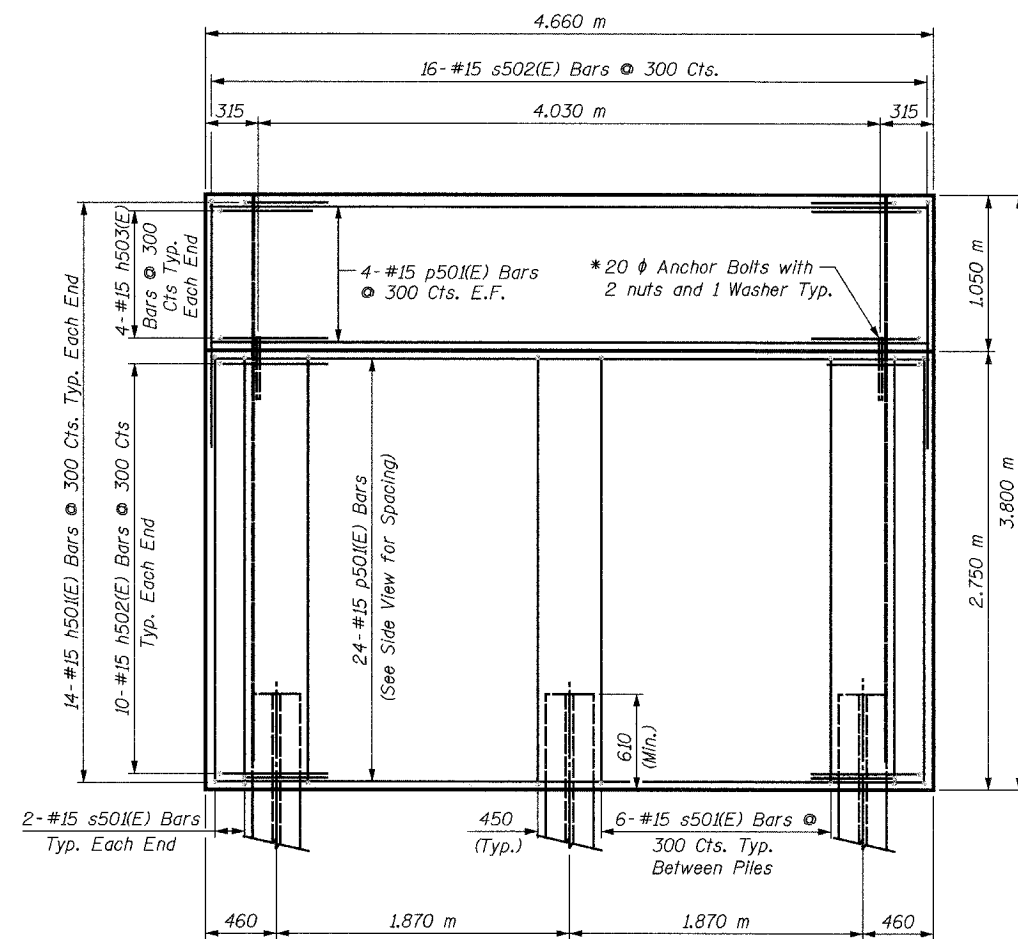

ELEVATION

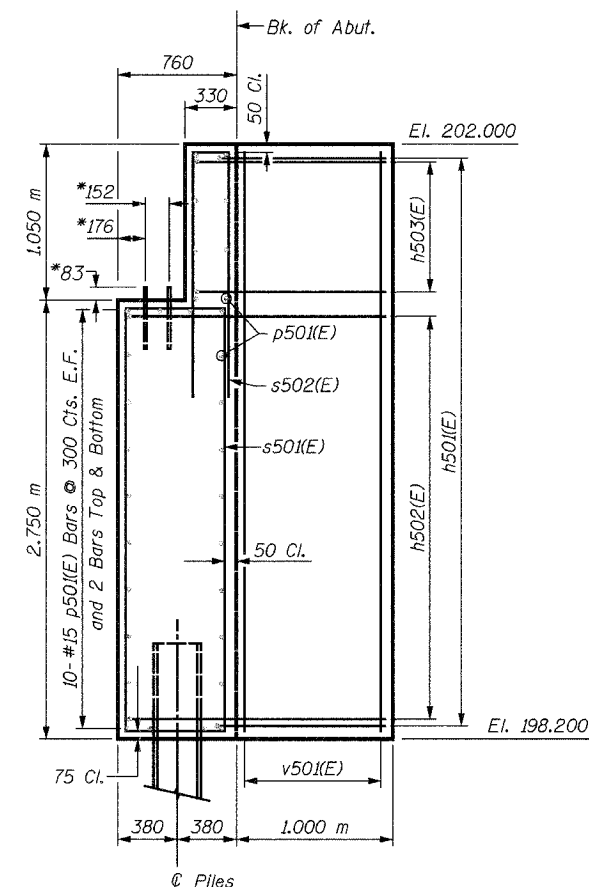

SIDE VIEW

*Anchor bolt size and locations shall be checked against the Bridge Fabricator's requirements prior to setting them.

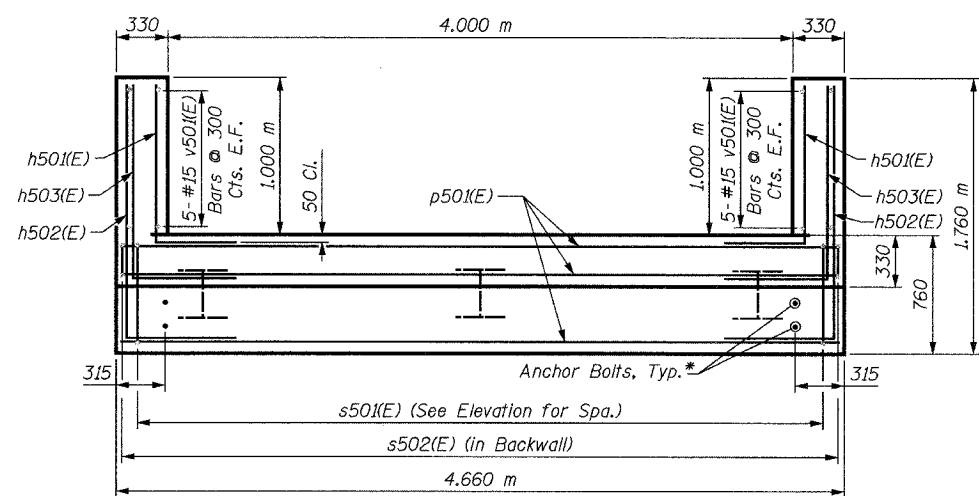

PLAN

Bar	A	B
h501(E)	0.900 m	1.000 m
h502(E)	0.900 m	1.640 m
h503(E)	0.900 m	1.220 m

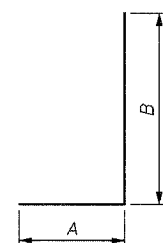

BAR h501(E) TO h503(E)

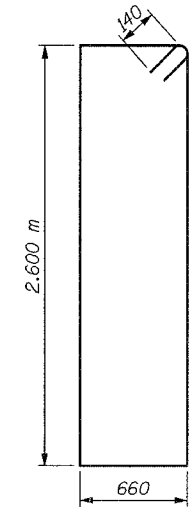

BAR s501(E)

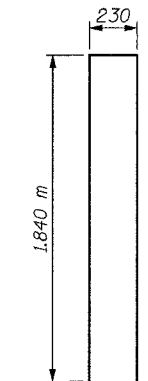

BAR s502(E)

BILL OF MATERIAL

Bar	No.	Size	Length	Shape
h501(E)	28	#15	1.90 m	□
h502(E)	20	#15	2.54 m	□
h503(E)	8	#15	2.12 m	□
p501(E)	32	#15	4.56 m	—
s501(E)	16	#15	6.84 m	□
s502(E)	16	#15	3.91 m	□
v501(E)	20	#15	3.67 m	—
Concrete Structures			Cu. M	14.0
Reinforcement Bars, Epoxy Coated			kg	810
Furnishing Steel Piles HP310x94			Meter	51
Driving Steel Piles			Meter	51
Metal Shoes			Each	3
Structure Excavation			Cu. M	31

LEGEND

E.F. = Each Face

MIN. BAR LAP

#15 = 890

PILE DATA:

Type: HP310x94
Capacity: Driven to Refusal
Est. Length: 17 m
No. Required: 3

NOTES:

- Space reinforcement in cap to miss anchor bolts.
- All edges shall have standard 20 mm chamfers except as noted.
- For Anchor Bolt Details, see Sheet S32.
- There shall be no splicing of longitudinal bars. Bars shall be ordered full length.
- Bars designated (E) shall be epoxy coated.

SHEET S30 of S33

REVISIONS		NAME	DATE
NO.	DESCRIPTION		

URS 1701 GOLF ROAD, SUITE 1000 TEL (847) 228-0707
ROLLING MEADOWS, IL 60008 FAX (847) 228-1115

VILLAGE OF OAKBROOK
SALT CREEK GREENWAY TRAIL
PEDESTRIAN BRIDGE, STA. 23+508.08
WEST ABUTMENT DETAILS

DATE: 06/30/05
DESIGNED BY: MDS
DRAWN BY: MDS
CHECKED BY: GAT

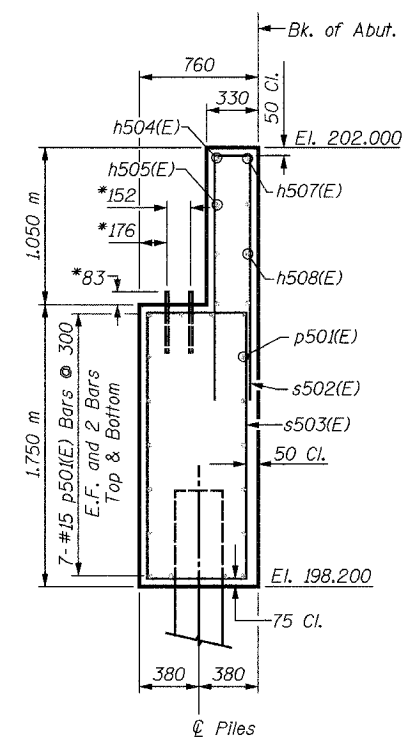
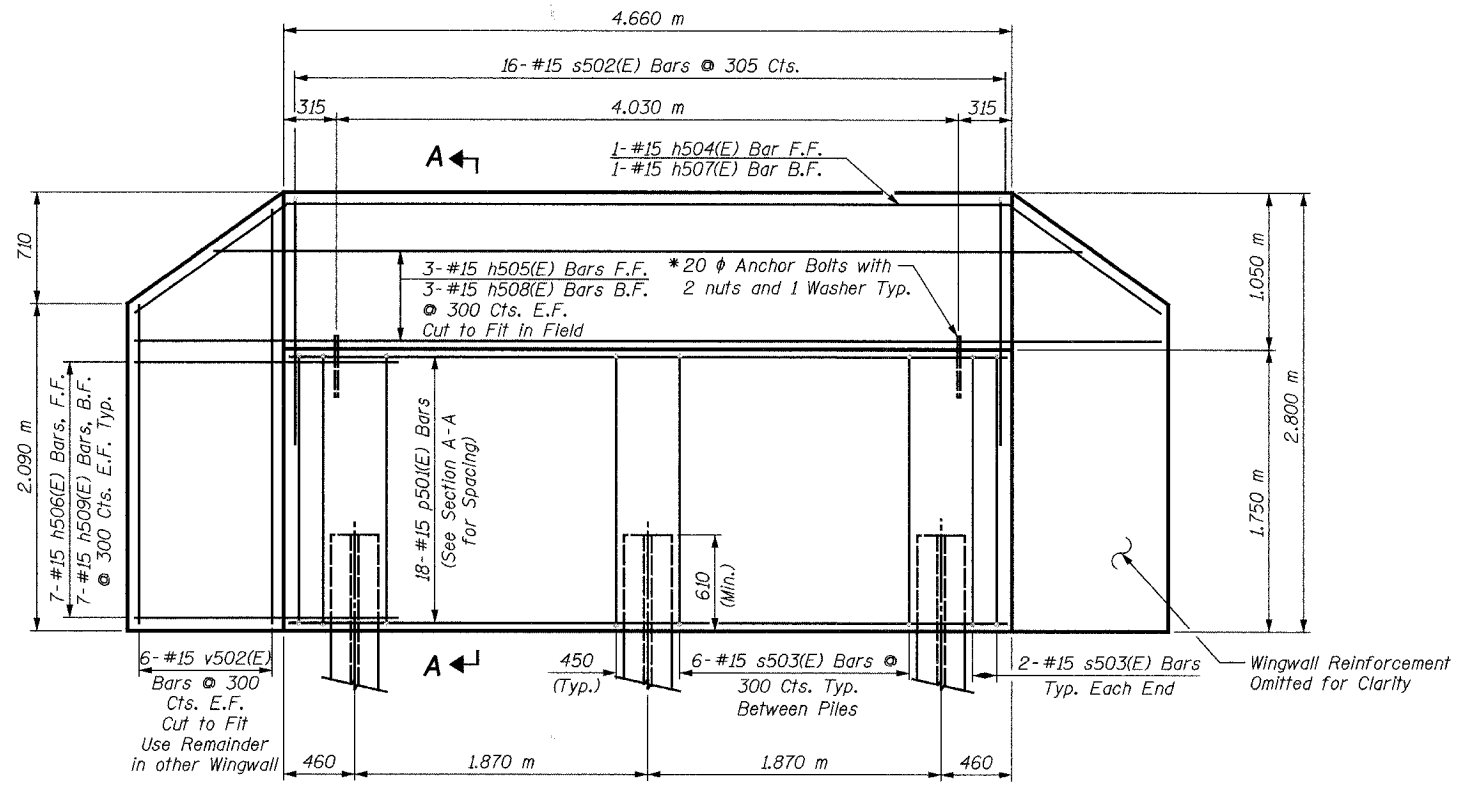

BILL OF MATERIAL

Bar	No.	Size	Length	Shape
h504(E)	1	#15	7.85 m	∩
h505(E)	3	#15	7.26 m	∩
h506(E)	14	#15	2.23 m	∩
h507(E)	1	#15	7.28 m	∩
h508(E)	3	#15	6.97 m	∩
h509(E)	14	#15	2.16 m	∩
p501(E)	18	#15	4.56 m	—
s502(E)	16	#15	3.91 m	□
s503(E)	16	#15	4.80 m	□
v502(E)	12	#15	4.64 m	—
Concrete Structures			Cu. M	10.2
Reinforcement Bars, Epoxy Coated			kg	630
Furnishing Steel Piles			Meter	34
HP310x79			Meter	34
Driving Steel Piles			Meter	34
Test Pile Steel HP310x79			Each	1
Metal Shoes			Each	2
Structure Excavation			Cu. M	12

ELEVATION

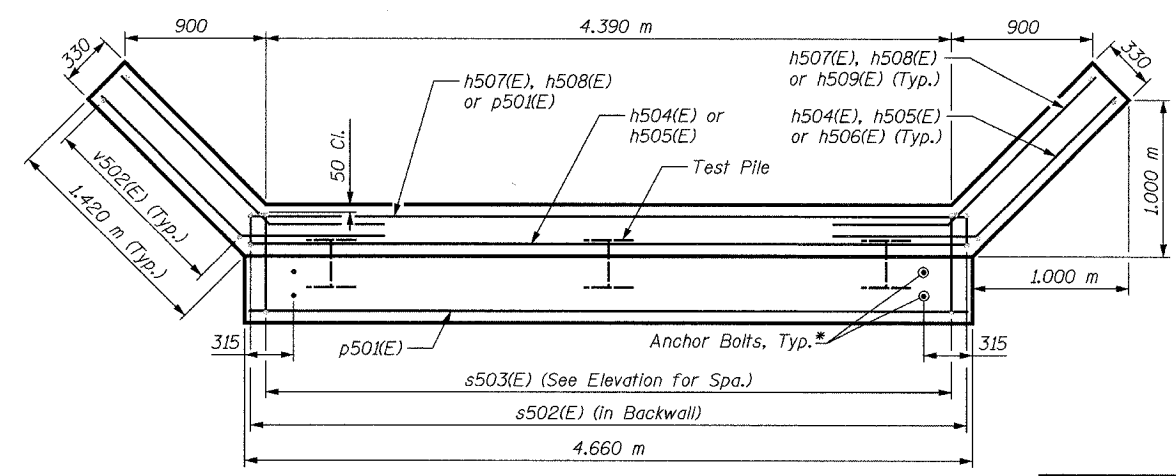

PILE DATA:

Typ. HP310x79
Capacity: Driven to Refusal
Est Length: 17 m
No. Required: 2 + 1 Test Pile

(Test Pile shall be a permanent pile driven at the East Abutment)

SECTION A-A

*Anchor bolt size and locations shall be checked against the Bridge Fabricator's requirements prior to setting them.

PLAN

Bar	A	B	L
h506(E)	0.940 m	0.940 m	0.900 m
h509(E)	0.890 m	0.890 m	0.900 m

BAR h506(E) & h509(E)

Bar	A	B	L
h504(E)	1.150 m	1.150 m	4.600 m
h505(E)	0.940 m	0.940 m	4.600 m
h507(E)	1.000 m	1.000 m	4.450 m
h508(E)	0.890 m	0.890 m	4.450 m

BARS h504(E), h505(E), h507(E) & h508(E)

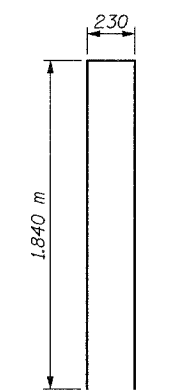

BAR s502(E)

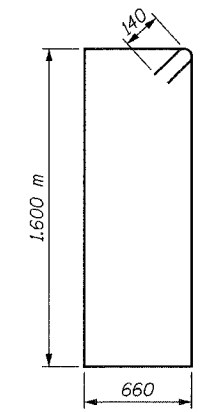

BAR s503(E)

NOTES:

- Space reinforcement in cap to miss anchor bolts.
- All edges shall have standard 20 mm chamfers except as noted.
- For Anchor Bolt Details, see Sheet S32.
- There shall be no splicing of longitudinal bars. Bars shall be ordered full length.
- Bars designated (E) shall be epoxy coated.

SHEET S31 of S33

REVISIONS		NAME	DATE

URS 1701 GOLF ROAD, SUITE 1000 TEL (847) 228-0707
ROLLING MEADOWS, IL 60008 FAX (847) 228-1115

VILLAGE OF OAKBROOK
SALT CREEK GREENWAY TRAIL
PEDESTRIAN BRIDGE, STA. 23+508.08
EAST ABUTMENT DETAILS

DATE: 06/30/05
DESIGNED BY: MDS
DRAWN BY: MDS
CHECKED BY: GAT

The Illinois Coil-Lock Anchor Bolt is a proprietary item which is the property of the Illinois Department of Transportation. Use, reproduction or disclosure without express written permission is prohibited and protected under Federal copyright laws. The production and the fabrication of this bolt for use on highway projects in the State of Illinois shall be permitted and there shall be no incurred charges or fees to the manufacturer or the fabricator for producing or fabricating this bolt.

D	E	H	K	"d"
24	27	20	44	6
30	33	26	51	10
36	39	32	54	13
48	51	44	73	15
64	67	60	86	25

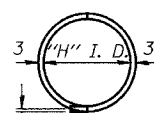
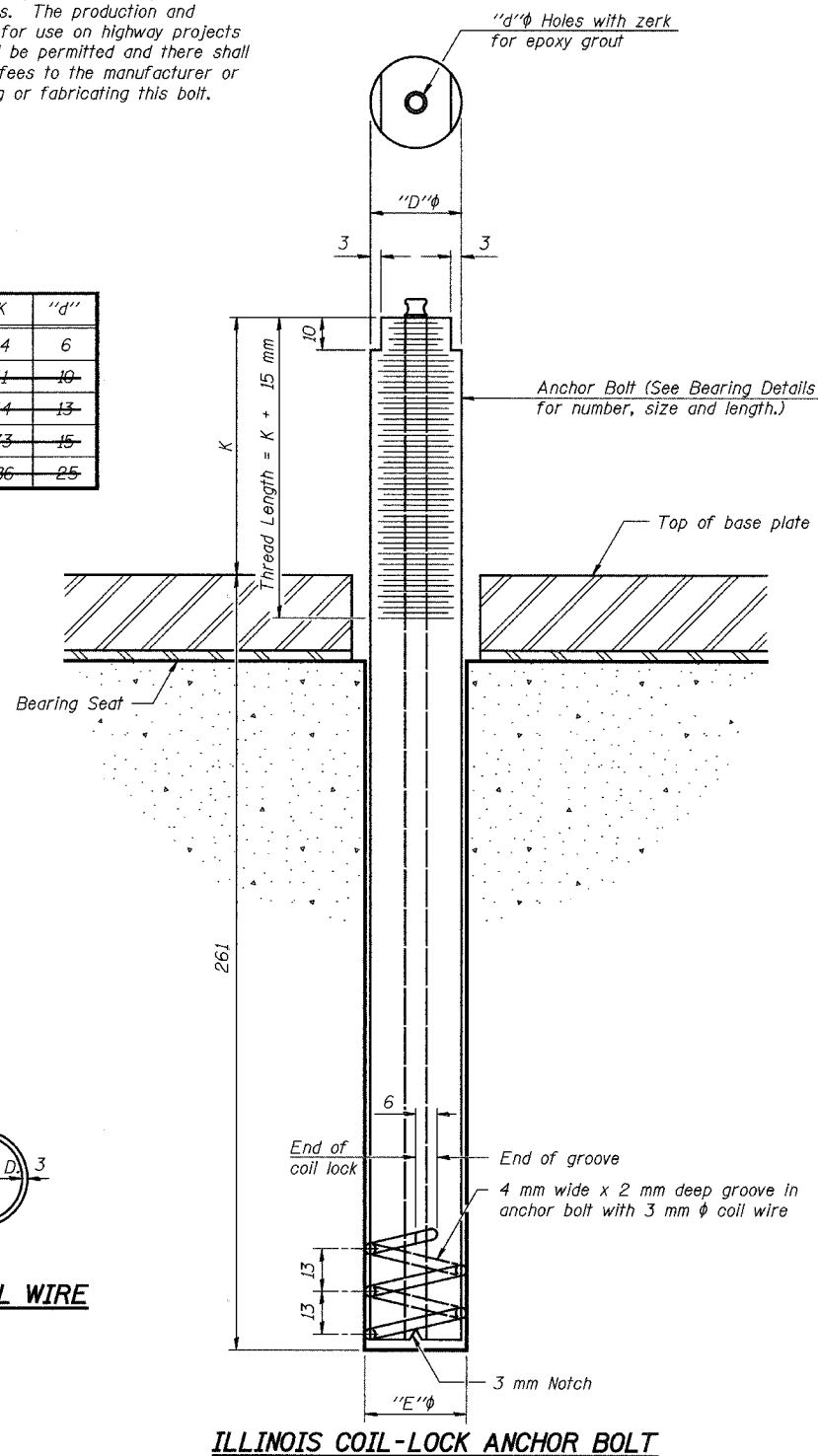

PLAN-COIL WIRE

ILLINOIS COIL-LOCK ANCHOR BOLT

MATERIALS FOR ILLINOIS COIL-LOCK ANCHOR BOLT

The anchor bolt shall be fabricated from cold drawn or hot finished seamless carbon steel mechanical tubing conforming to ASTM A 519, Grade 1026, CW and supplied with hexagonal nuts and cut washers.

The coil wire shall be made of any suitable soft steel wire. The finished anchor bolt shall be cleaned of rust and other foreign materials and wrapped or packaged to prevent contamination until they are installed. The epoxy grout shall be a two-component, epoxy resin bonding system conforming to ASTM C 881, Type I, Grade 1 and of a Class suitable for the temperature at installation.

INSTALLATION PROCEDURE for the ILLINOIS COIL-LOCK ANCHOR BOLT

1. With the coil wire in place, the bolt shall be inserted into the hole and turned clockwise to a snug fit in the hole. Nut and washer shall be placed on the bolt. The nut shall be tensioned until the steel base plates are held securely to the concrete bearing seat.
2. Epoxy grout shall be pumped through the zerk fitting with a pressure gun. Pumping shall continue until the epoxy overflows the hole around the bolt shank. After pumping is discontinued, excess epoxy shall be immediately wiped off.

ALTERNATE ANCHOR BOLTS

The Contractor may use, at his option, the capsule or the adhesive cartridge type anchor rods that have been previously tested and given a prior approval by the Department. The Contractor shall install these anchor rods in pre-drilled holes according to the manufacturer's recommendations and procedures.

- The capsule or the adhesive cartridge type anchor rods shall be a two part system composed of:
1. A threaded rod stud with nut and washer of the type specified.
 2. A sealed glass capsule or a sealed glass adhesive cartridge containing premeasured amounts of the adhesive chemical.

Size	Type
M24 x 305	A 307

ASTM F 1554 (Fy = 724 MPa), ASTM A 449 and AASHTO M 314 (Fy = 724 MPa) anchor bolts may be substituted for the anchor bolts shown above.

GENERAL NOTES

Holes in the masonry for anchor bolts shall be drilled through the base plates to the diameter and depth shown or according to the manufacturer's recommendation after beams or girders have been erected and adjusted. Prior to setting the bolts, the holes shall be dry and all dust and loose particles shall be removed by the use of compressed air or vacuuming. The anchor bolts, furnished and installed and including the epoxy grout or capsules shall not be paid for separately but shall be included in the unit bid price for Pedestrian Bridge, 44 m.

REVISIONS		URS	1701 GOLF ROAD, SUITE 1000 ROLLING MEADOWS, IL 60008	TEL (847) 228-0707 FAX (847) 228-1115
NAME	DATE			
		VILLAGE OF OAKBROOK SALT CREEK GREENWAY TRAIL ANCHOR BOLT DETAIL		
		DATE: 06/30/05	DRAWN BY: MDS	
		DESIGNED BY: MDS	CHECKED BY: GAT	

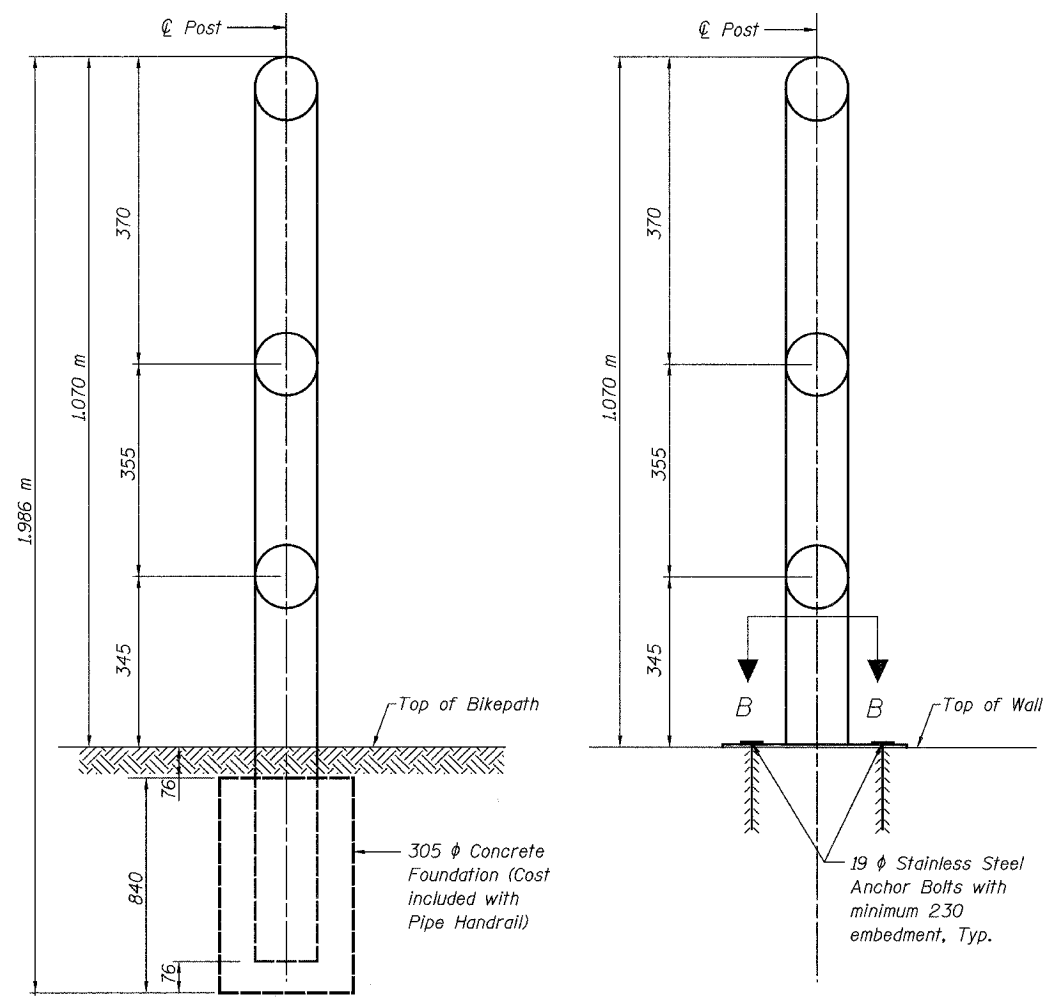

DETAIL - GROUND MOUNTED RAIL POST **DETAIL - WALL MOUNTED RAIL POST**

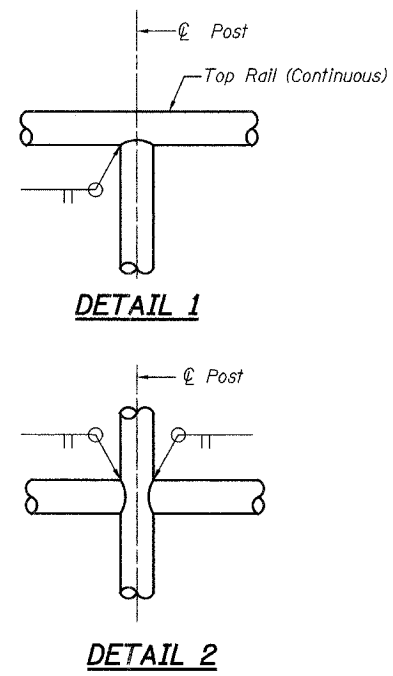

DETAIL 1
DETAIL 2

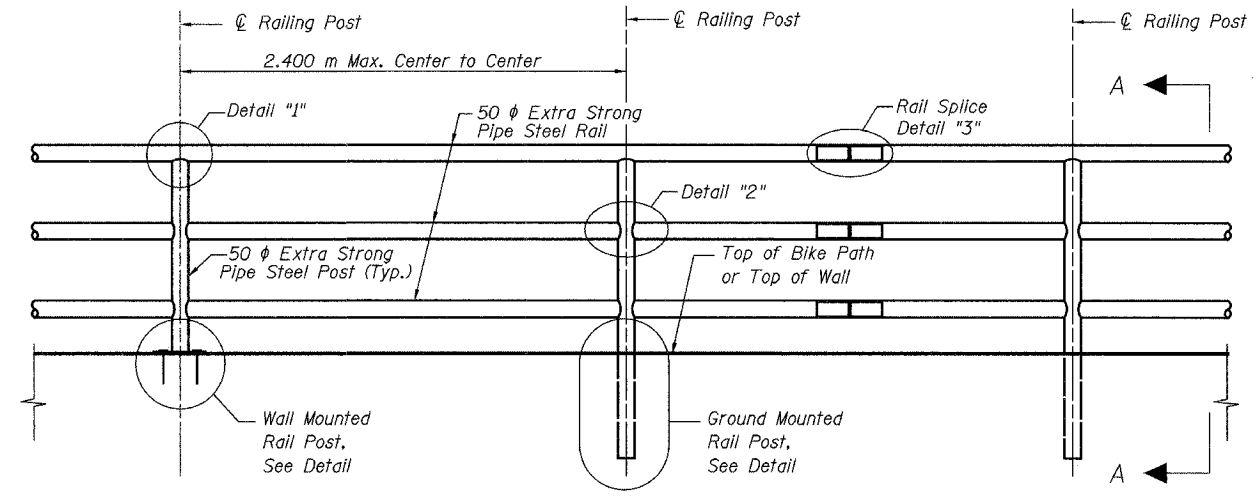

TYPICAL PIPE HANDRAIL ELEVATION

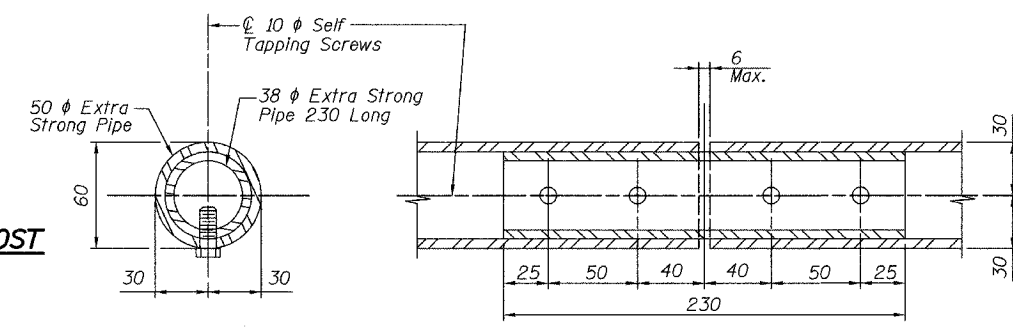

DETAIL 3 - RAIL SPLICE

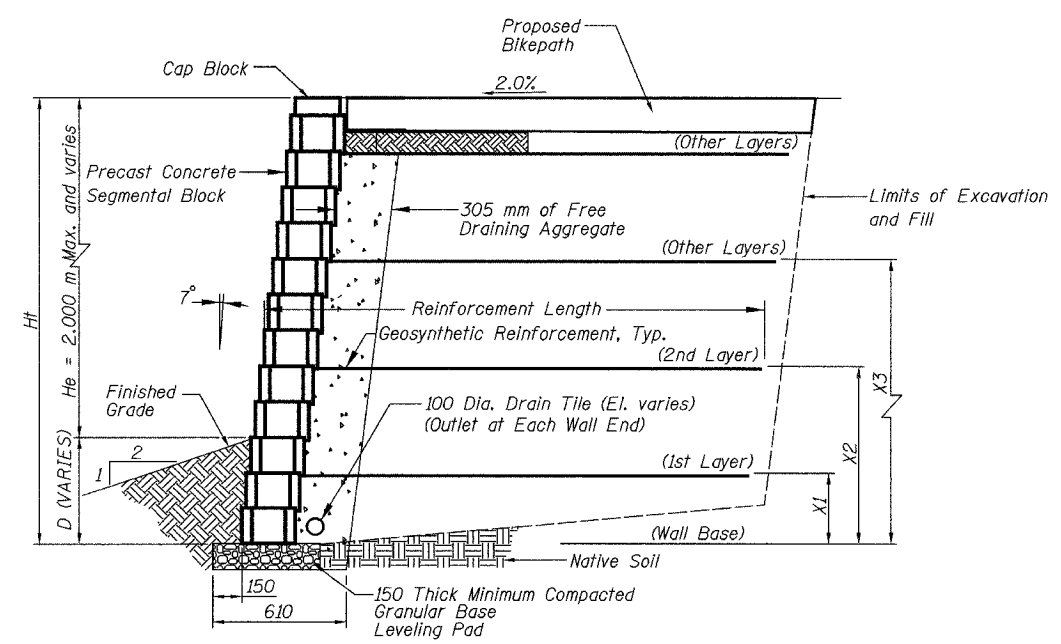

TYPICAL SECTION THROUGH SEGMENTAL CONCRETE BLOCK WALL

Notes: Hf, X1, X2 and X3 to be determined by Fabricator

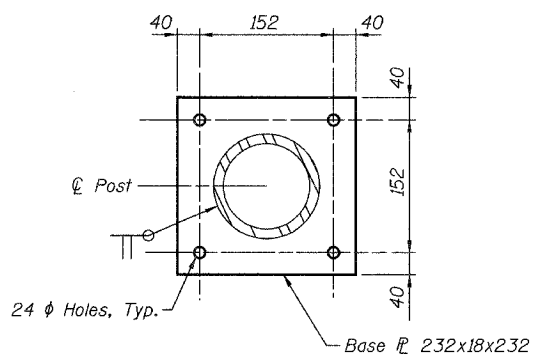

SECTION B-B

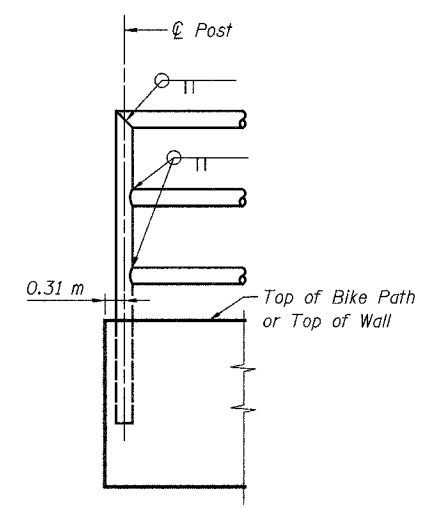

ELEVATION SHOWING END POST

NOTES:

1. The Contractor shall submit design, construction plans with material information, and shop drawings, including connection details, signed by a Structural Engineer licensed in the state of Illinois to the Engineer for approval before ordering materials.
2. Segmental Concrete Block Wall shall be designed to resist equivalent fluid pressure = 6.3 kN/Cu. M.
3. Design of the Segmental Concrete Block Wall shall be in compliance with the guidelines for the design of mechanically stabilized earth walls as developed by AASHTO-AGC-ARTA Joint Committee Task Force 27 Ground Modification Systems.
4. Railing shall be according to Section 509 of the Standard Specifications, except as noted, and will be paid for at the contract unit price per meter.
5. Hollow structural steel tubing shall conform to the requirements of ASTM designation A 500, Grade B, Structural Steel Tubing.
6. All other steel shapes and plates shall conform to the requirements of AASHTO M-270M, Grade 345.
7. All posts, railing, splices, anchor devices, and bent plates shall be galvanized after shop fabrication according to AASHTO M-111 and ASTM A-385. All bolts, nuts and washers shall be galvanized according to AASHTO M-232 except stainless steel bolts as noted.
8. Vent holes for galvanizing shall be placed in the posts and rails at locations that will not allow the accumulation of moisture in the members.
9. Rail to match horizontal profile of bikepath.

SHEET S33 of S33

REVISIONS		NAME	DATE
NO.	DESCRIPTION		

URS

1701 GOLF ROAD, SUITE 1000
ROLLING MEADOWS, IL 60008

TEL (847) 228-0707
FAX (847) 228-1115

VILLAGE OF OAKBROOK

SALT CREEK GREENWAY TRAIL

**TYPICAL SEGMENTAL CONCRETE
BLOCK WALL DETAILS**

DATE: 06/30/05
DESIGNED BY: MDS

DRAWN BY: MDS
CHECKED BY: GAT

FINAL SURVEY PLATTED
 NOTE BOOK NO. _____
 AREAS CHECKED _____

ORIGINAL SURVEY PLATTED
 NOTE BOOK NO. _____
 AREAS CHECKED _____

F.A. RTE.	SECTION	COUNTY	TOTAL SHEETS	SHEET NO.
	02-00034-00-BT	DUPAGE	108	70
STA.	TO STA.			
FED. ROAD DIST. NO.	ILLINOIS FED. AID PROJECT		CONTRACT NO. 83714	

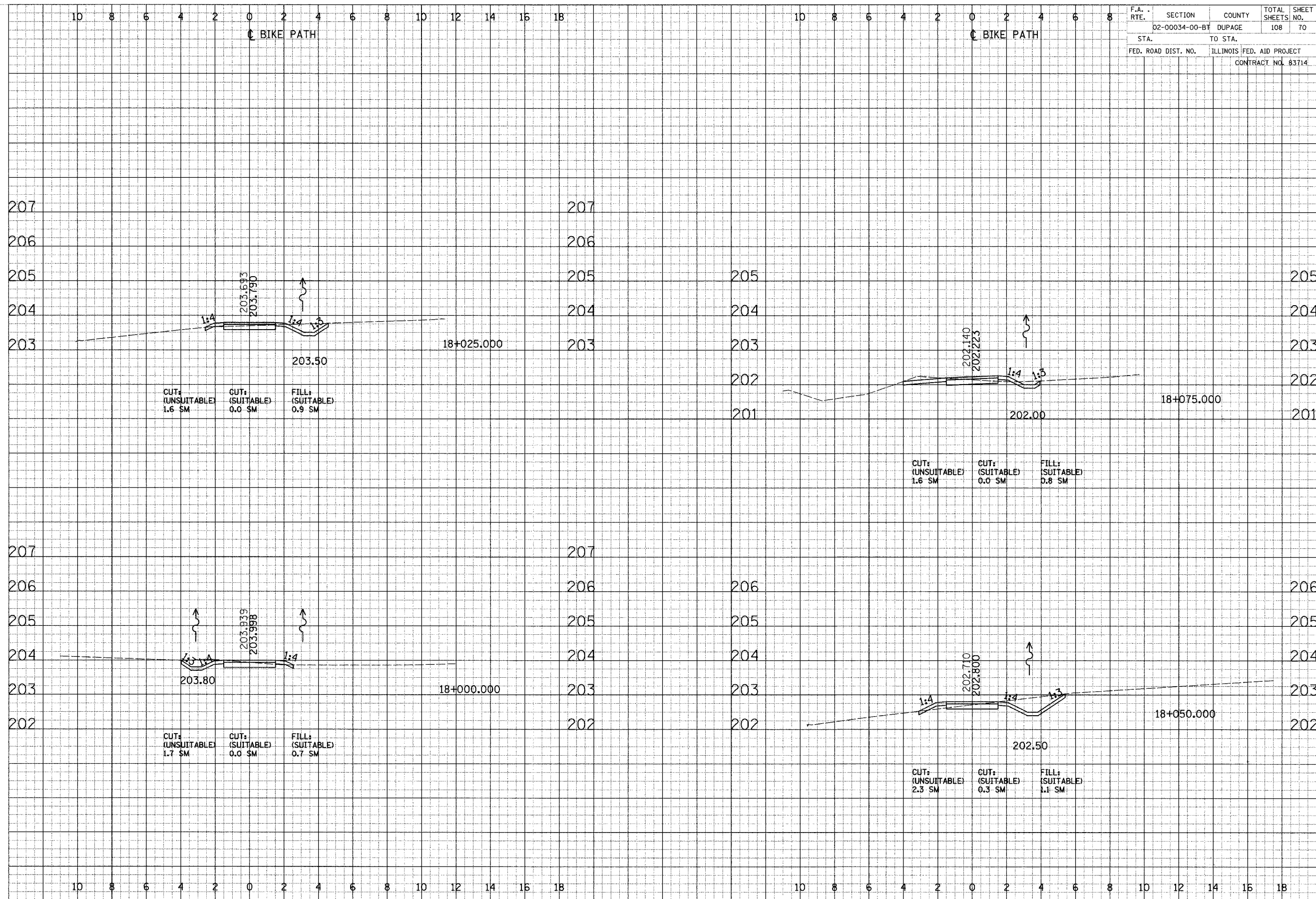

CROSS SECTIONS - SOUTH DUPAGE

DATE: _____ BY: _____
 SURVEYED: _____
 PLOTTED: _____
 CHECKED: _____
 FINAL SURVEY: _____
 NOTE BOOK: _____
 NO. _____
 AREAS CHECKED: _____

DATE: _____ BY: _____
 SURVEYED: _____
 PLOTTED: _____
 CHECKED: _____
 ORIGINAL SURVEY: _____
 NOTE BOOK: _____
 NO. _____
 AREAS CHECKED: _____

F.A. RTE.	SECTION	COUNTY	TOTAL SHEETS	SHEET NO.
	02-00034-00-BT	DUPAGE	108	72
STA.	TO STA.		ILLINOIS FED. AID PROJECT	
FED. ROAD DIST. NO.			CONTRACT NO. 83714	

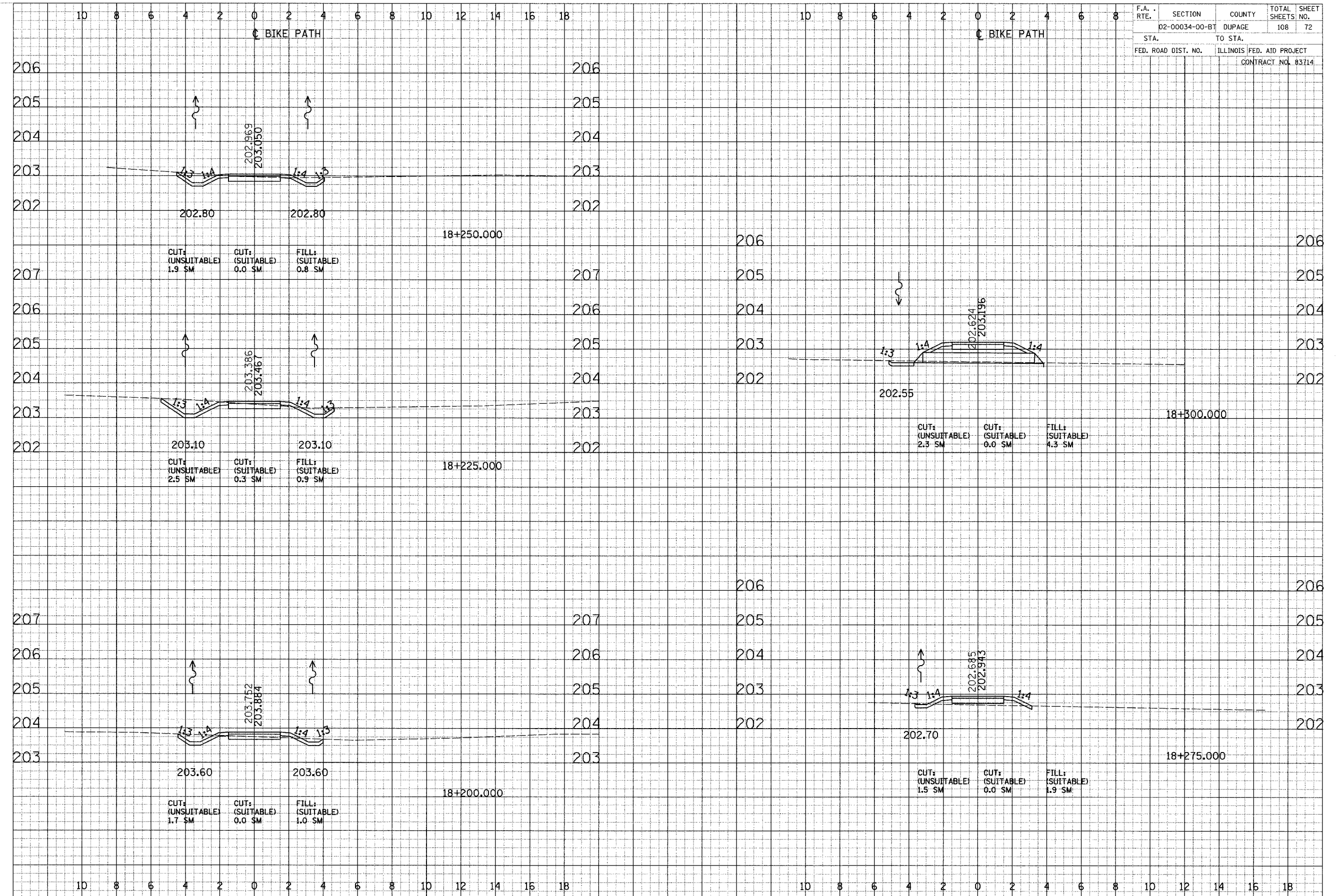

CROSS SECTIONS - SOUTH DUPAGE

DRAWING NO. _____
 SHEET NO. _____
 DATE _____
 BY _____
 CHECKED _____
 DESIGNED _____
 PLANNED _____
 PLOTTED _____
 NOTE BOOK _____
 NO. _____
 AREAS CHECKED _____

DRAWING NO. _____
 SHEET NO. _____
 DATE _____
 BY _____
 CHECKED _____
 DESIGNED _____
 PLANNED _____
 PLOTTED _____
 NOTE BOOK _____
 NO. _____
 AREAS CHECKED _____

F.A. RTE.	SECTION	COUNTY	TOTAL SHEETS	SHEET NO.
	02-00034-00-BT	DUPAGE	108	73
STA.	TO STA.			
FED. ROAD DIST. NO.	ILLINOIS FED. AID PROJECT			
	CONTRACT NO. 83714			

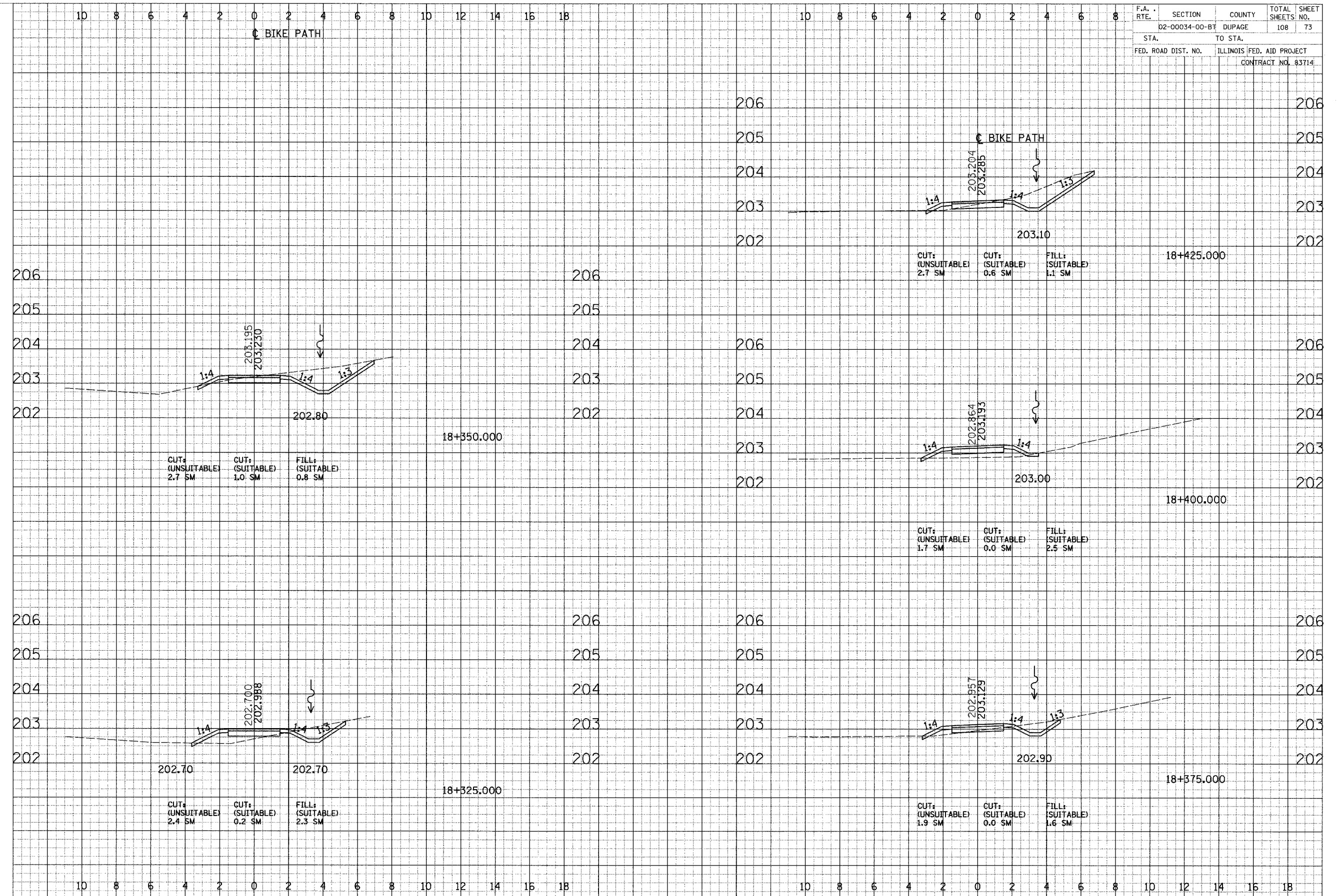

CROSS SECTIONS - SOUTH DUPAGE

FINISHED SURVEY PLOTTED
 NOTE BOOK
 AREAS CHECKED

ORIGINAL SURVEY PLOTTED
 NOTE BOOK
 AREAS CHECKED

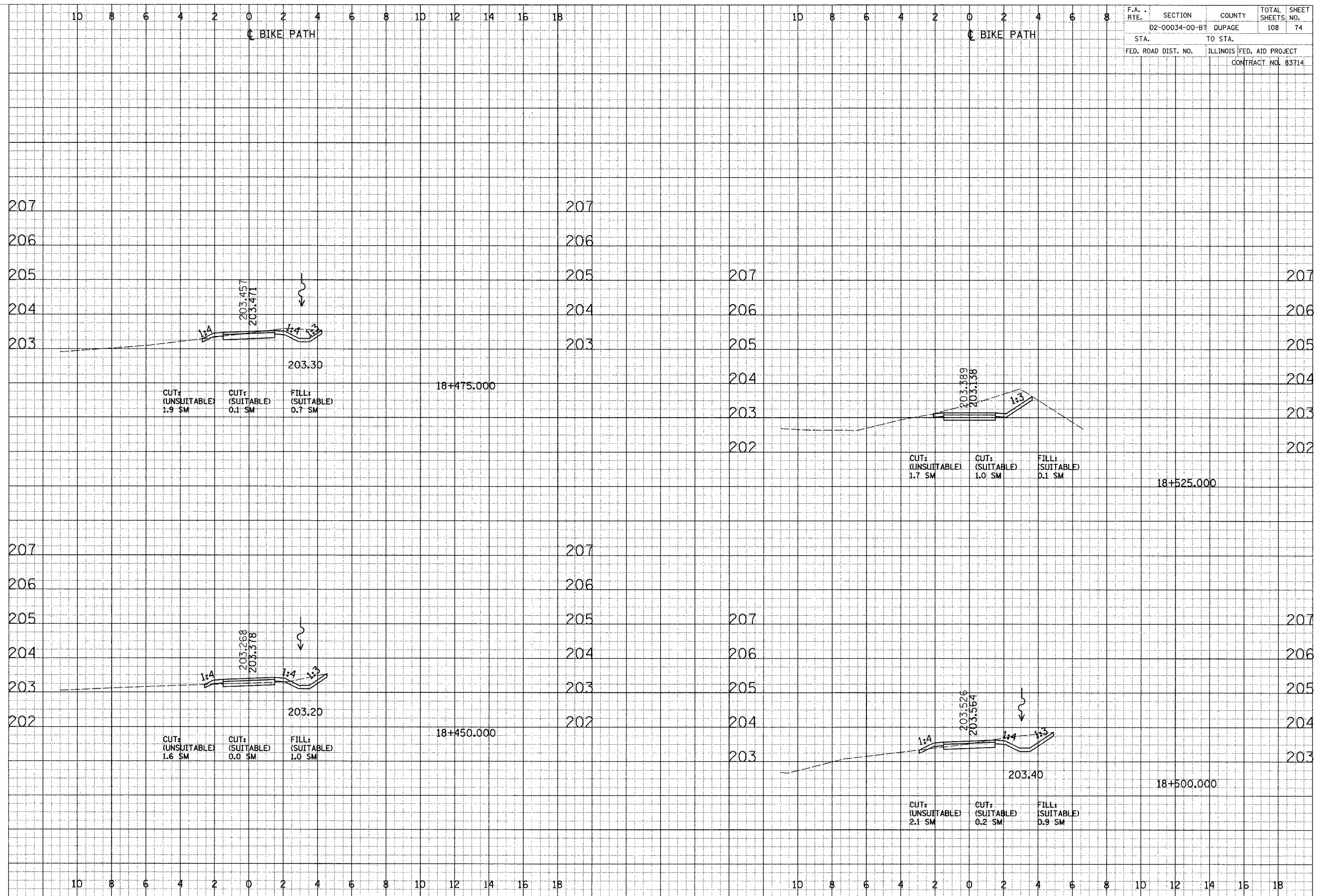

F.A. RTE.	SECTION	COUNTY	TOTAL SHEETS	SHEET NO.
	02-00034-00-BT	DUPAGE	108	74
STA.	TO STA.			
FED. ROAD DIST. NO.	ILLINOIS	FED. AID PROJECT		
	CONTRACT NO. 83714			

CROSS SECTIONS - SOUTH DUPAGE

SURVEYED BY _____ DATE _____
 CHECKED BY _____
 ORIGINAL DRAWING NO. _____
 DATE _____
 REVISIONS: _____
 DATE _____
 BY _____
 CHECKED BY _____
 APPROVED BY _____
 DATE _____

SURVEYED BY _____ DATE _____
 CHECKED BY _____
 ORIGINAL DRAWING NO. _____
 DATE _____
 REVISIONS: _____
 DATE _____
 BY _____
 CHECKED BY _____
 APPROVED BY _____
 DATE _____

F.A. RTE.	SECTION	COUNTY	TOTAL SHEETS	SHEET NO.
	02-00034-00-BT	DUPAGE	108	75
STA.	TO STA.			
FED. ROAD DIST. NO.	ILLINOIS	FED. AID PROJECT		
CONTRACT NO. 83714				

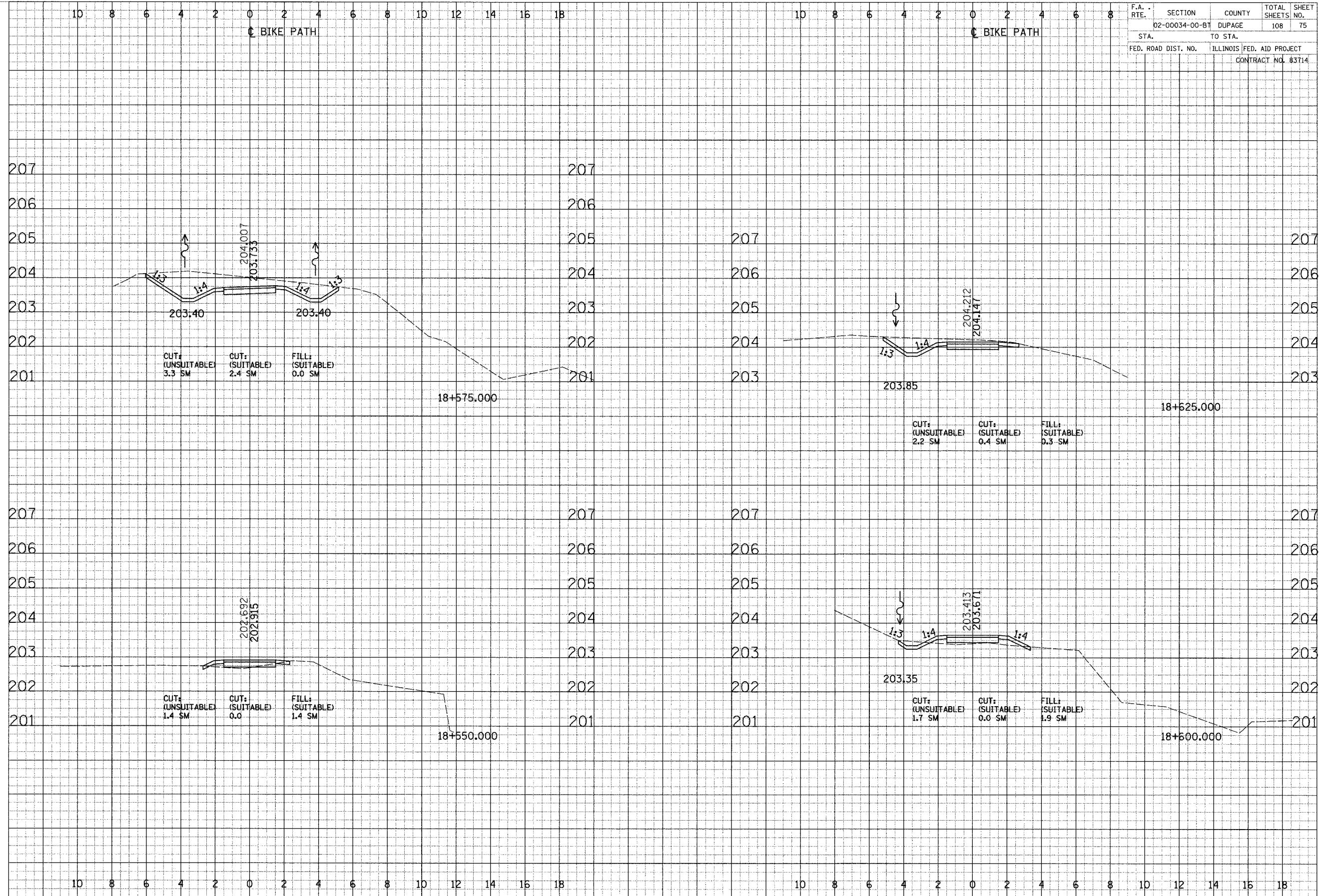

CROSS SECTIONS - SOUTH DUPAGE

F.A. RTE.	SECTION	COUNTY	TOTAL SHEETS	SHEET NO.
02-00034-00-BT	DUPAGE	DUPAGE	108	76
STA.	TO STA.	ILLINOIS FED. AID PROJECT		
FED. ROAD DIST. NO.		CONTRACT NO. 83714		

DATE: _____ BY: _____
 SURVEYED: _____
 NOTE BOOK: _____
 AREA: _____
 CHECKED: _____

DATE: _____ BY: _____
 SURVEYED: _____
 NOTE BOOK: _____
 AREA: _____
 CHECKED: _____

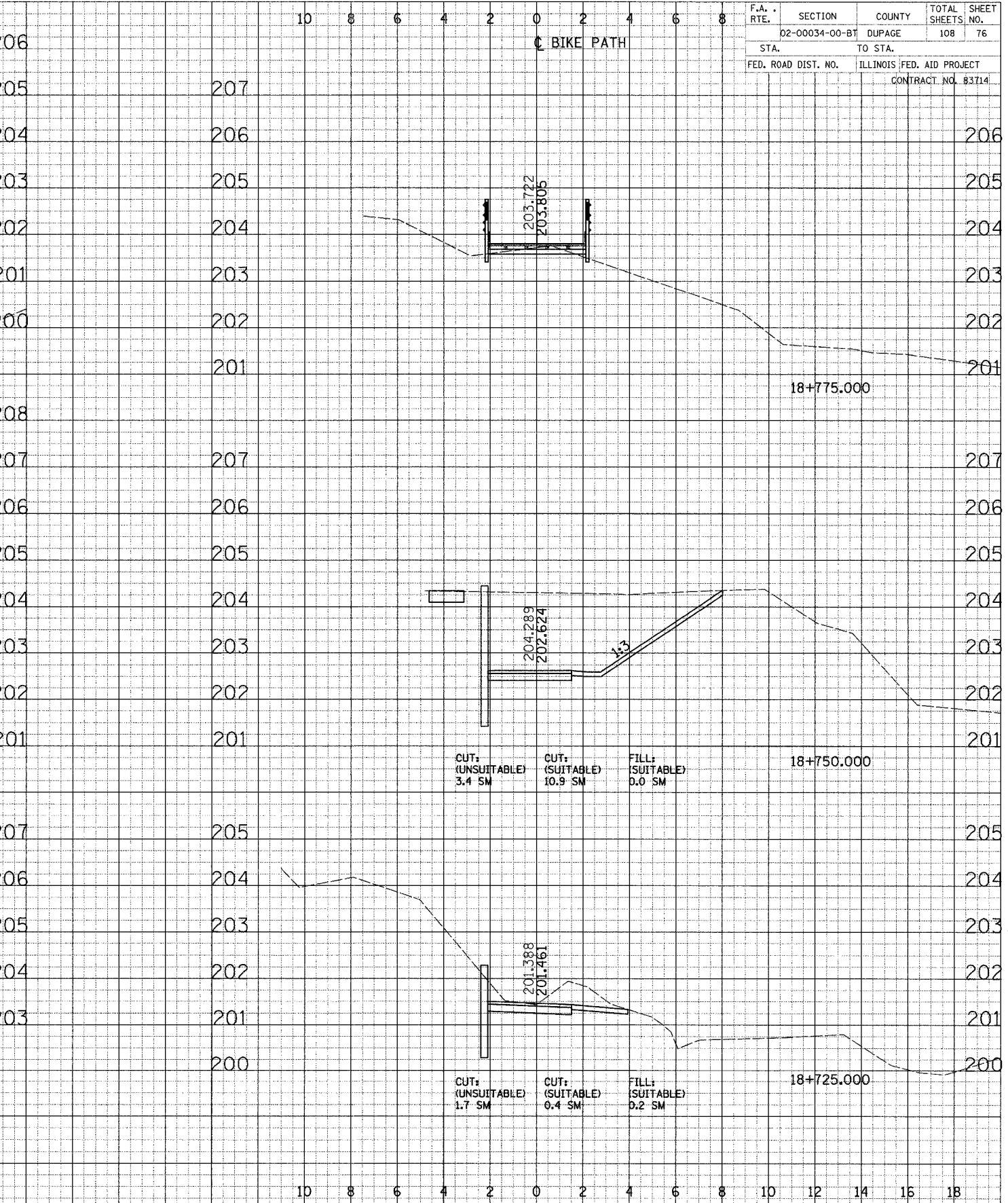
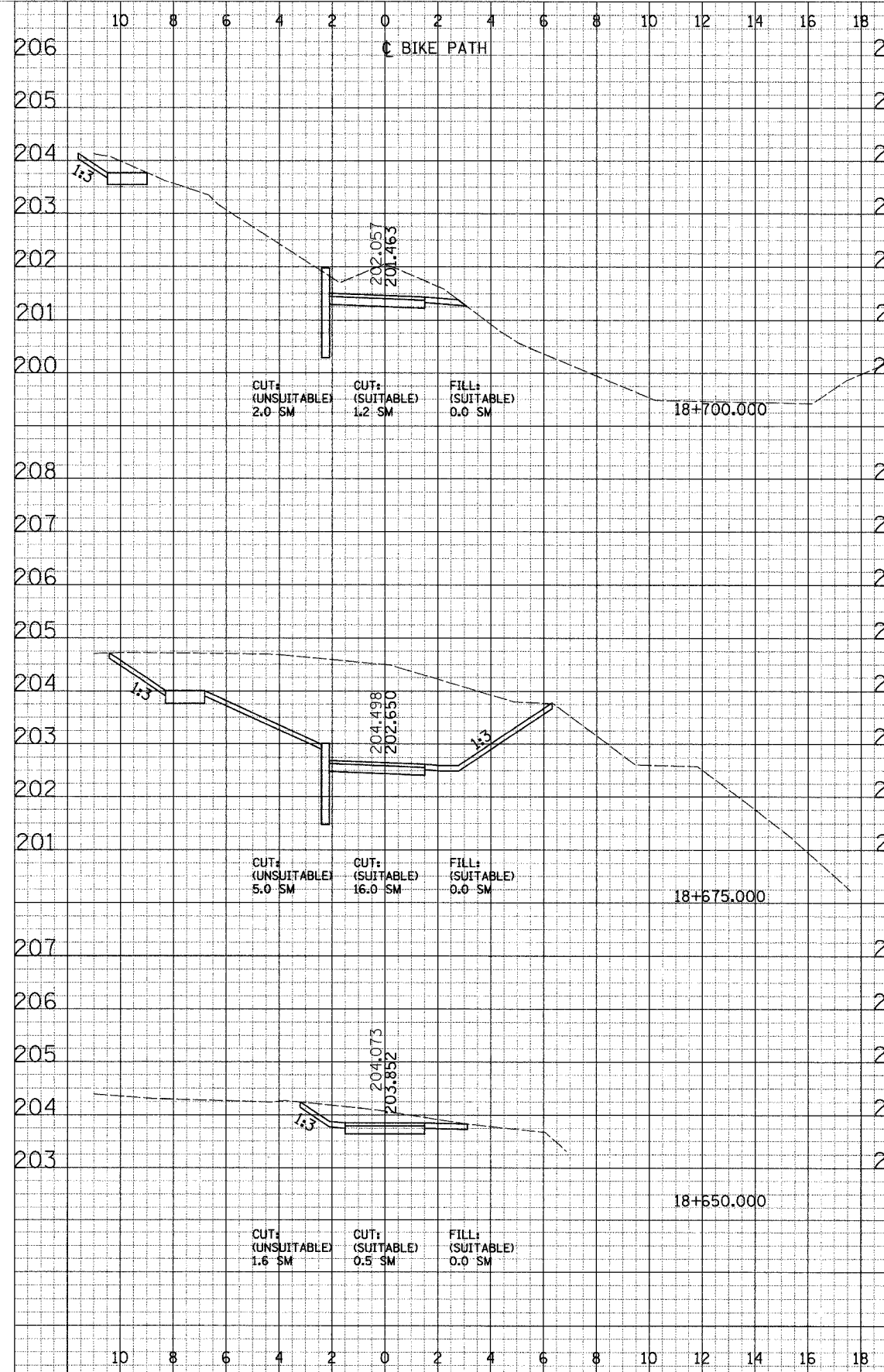

CROSS SECTIONS - SOUTH DUPAGE

FINAL SURVEY BY DATE
 SURVEY ELECTRIC PLANNING
 NOTE BOOK REVISIONS
 REVISIONS REVISIONS REVISIONS

ORIGINAL SURVEY BY DATE
 SURVEY ELECTRIC PLANNING
 NOTE BOOK REVISIONS
 REVISIONS REVISIONS REVISIONS

F.A. RTE.	SECTION	COUNTY	TOTAL SHEETS	SHEET NO.
	02-00034-00-BT	DUPAGE	108	77
STA.	TO STA.			
FED. ROAD DIST. NO.	ILLINOIS	FED. AID PROJECT	CONTRACT NO. 83714	

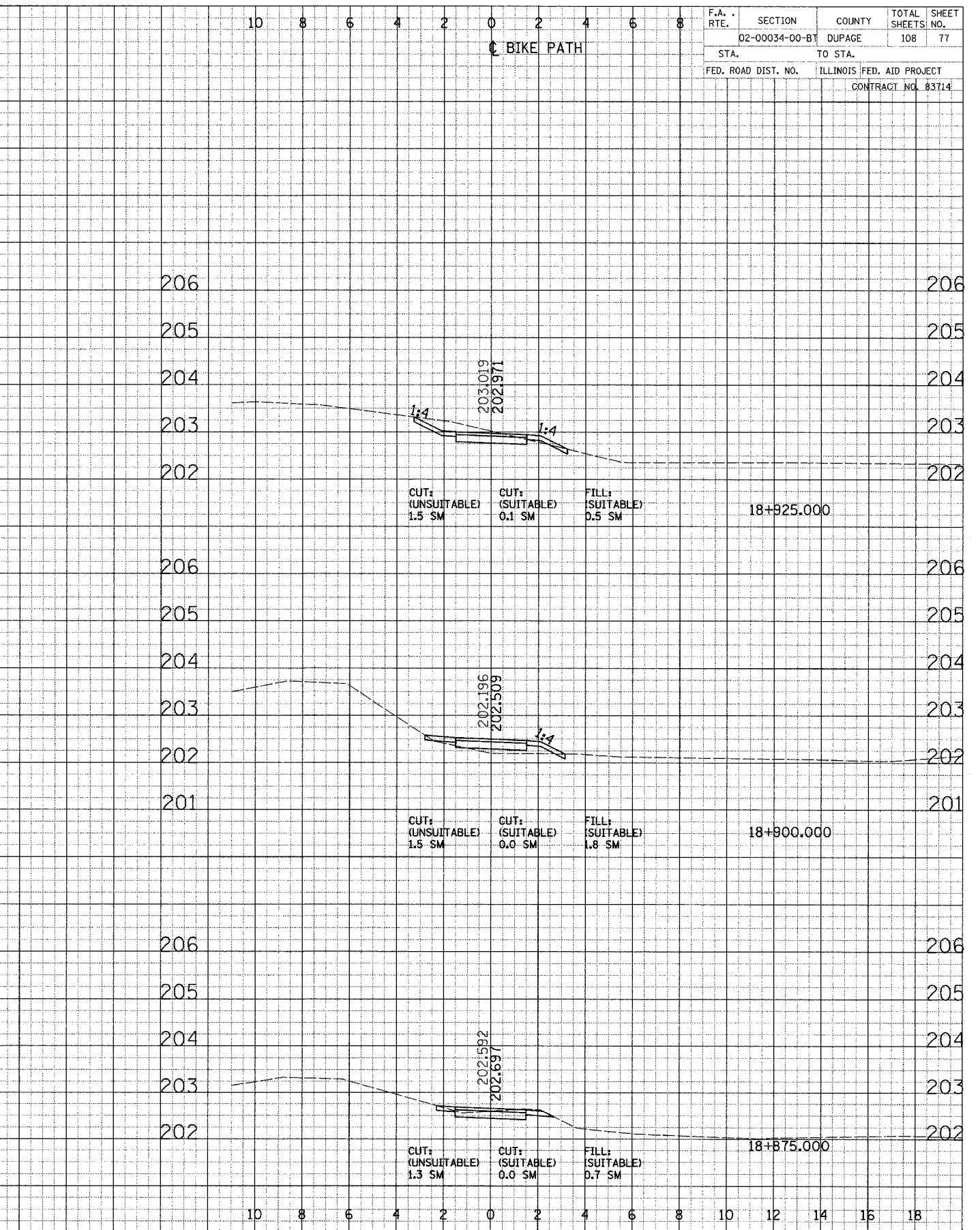
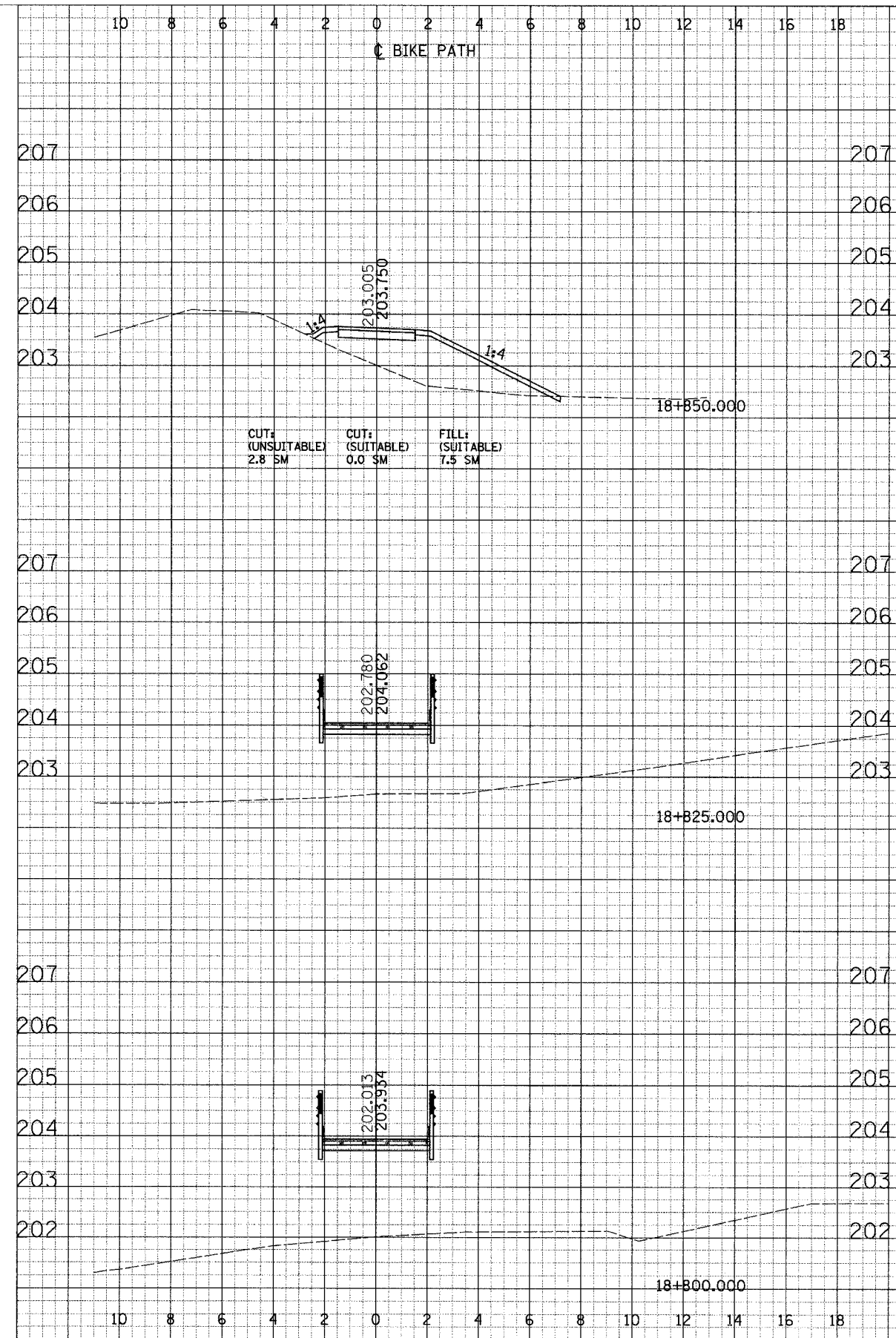

CROSS SECTIONS - SOUTH DUPAGE

F.A. RTE.	SECTION	COUNTY	TOTAL SHEETS	SHEET NO.
	02-00034-00-BT	DUPAGE	108	78
STA.		TO STA.		
FED. ROAD DIST. NO.	ILLINOIS	FED. AID PROJECT	CONTRACT NO. 83714	

FINAL SURVEY	DATE
PLANNED	
REPLATE	
NOTE BOOK	
APPROX. NEEDED	

ORIGINAL SURVEY	DATE
PLANNED	
REPLATE	
NOTE BOOK	
APPROX. NEEDED	

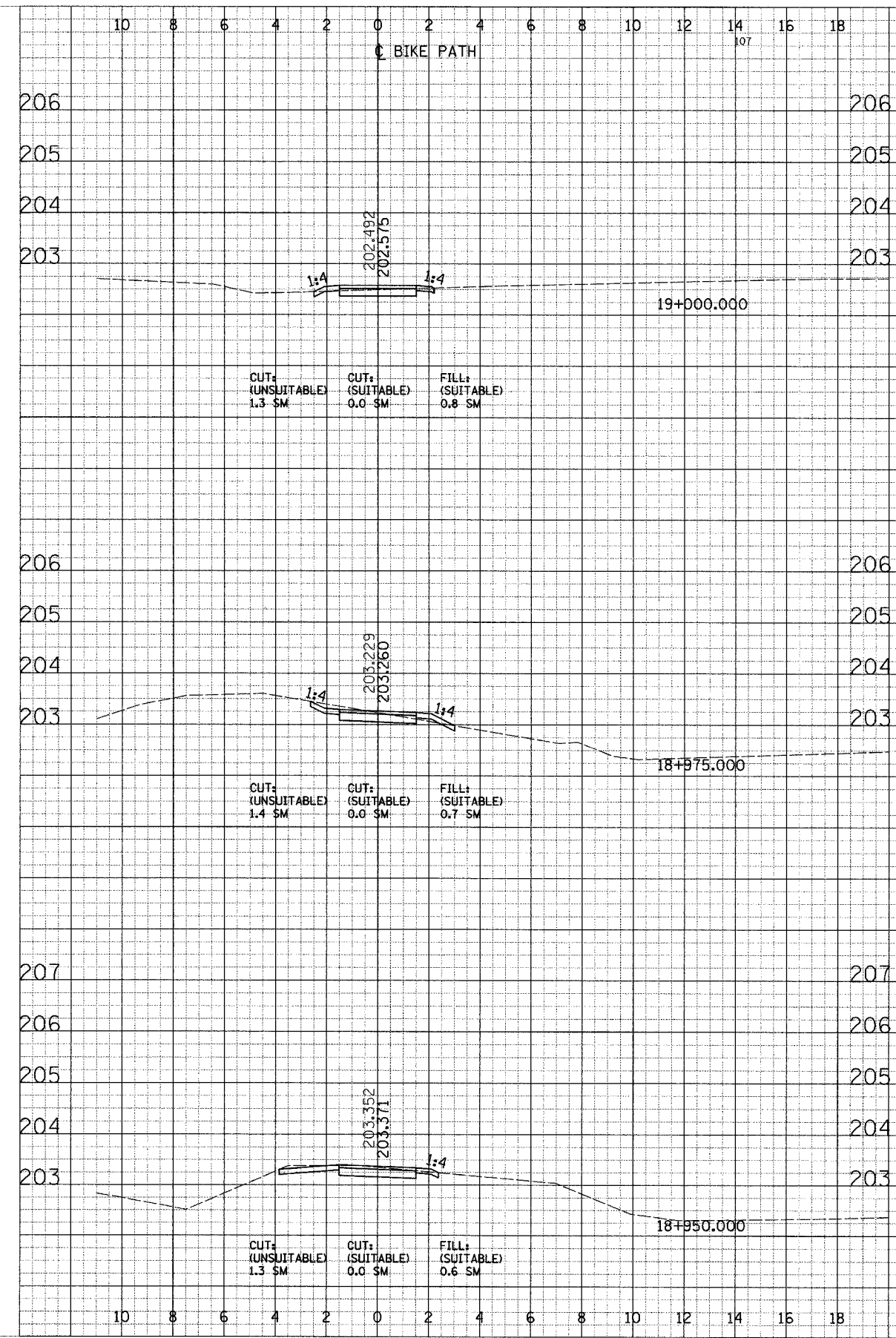

CROSS SECTIONS - SOUTH DUPAGE

F.A. RTE.	SECTION	COUNTY	TOTAL SHEETS	SHEET NO.
02-00034-00-BT	DUPAGE		108	79
STA.		TO STA.		
FED. ROAD DIST. NO.	ILLINOIS	FED. AID PROJECT		
		CONTRACT NO. 83714		

FINAL	REVISION	DATE
SHEET	PLotted	
NOTE BOOK	DATE	
NO.	APPROVED	

ORIGINAL	DATE
SHEET	
NOTE BOOK	
NO.	

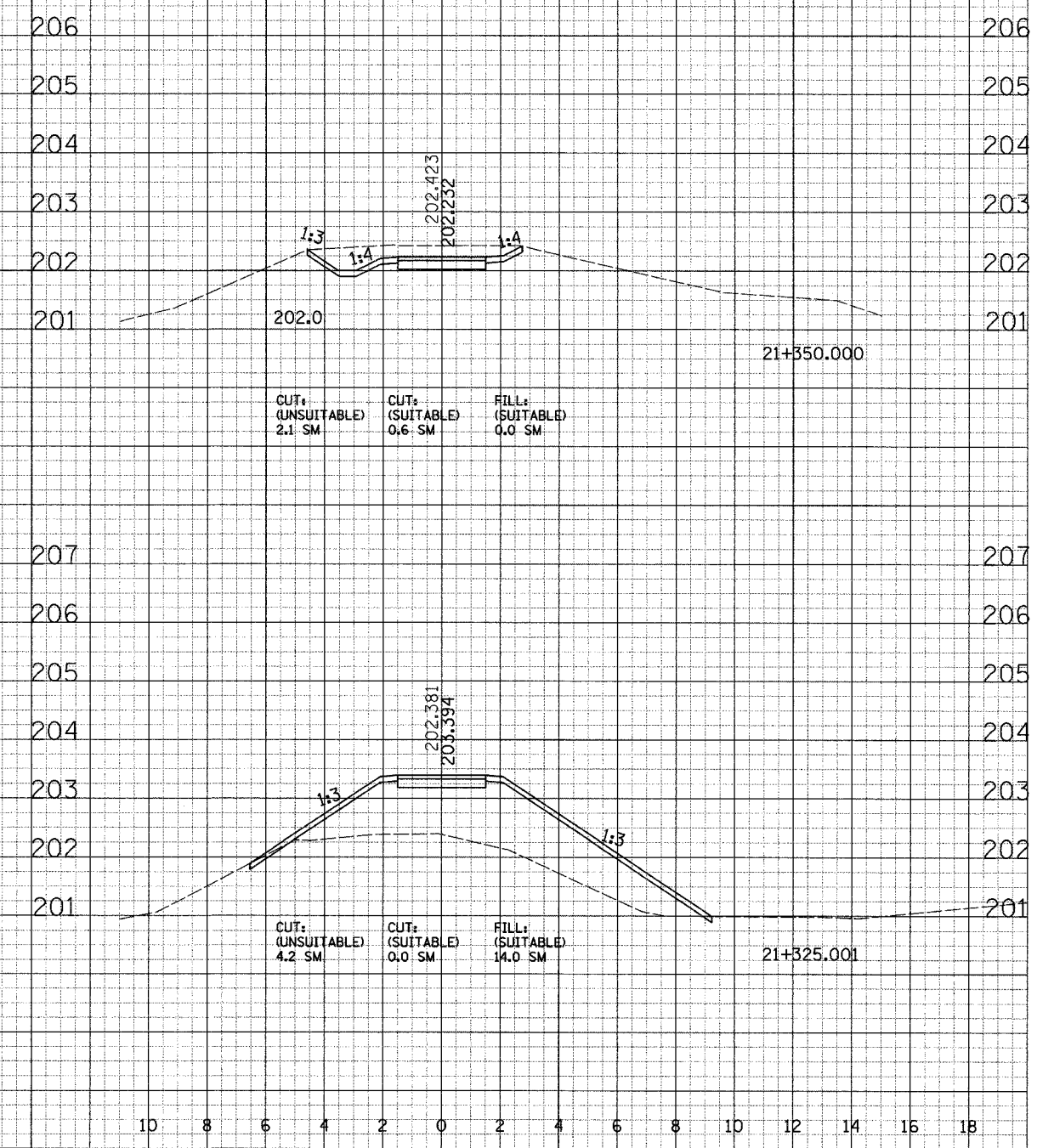
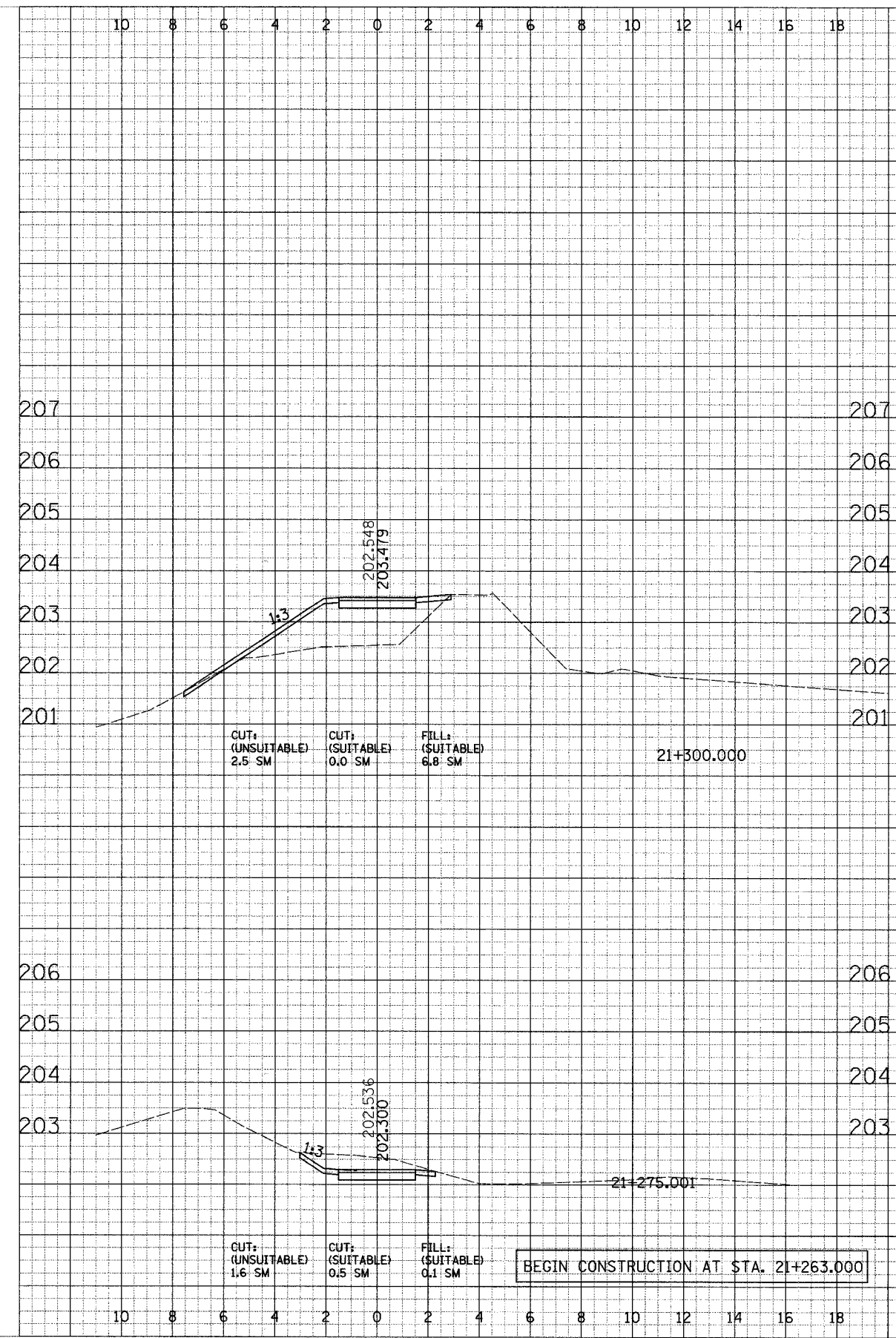

CROSS SECTIONS - SOUTH DUPAGE

F.A. RTE.	SECTION	COUNTY	TOTAL SHEETS	SHEET NO.
	02-00034-00-BT	DUPAGE	108	80
STA.	TO STA.			
FED. ROAD DIST. NO.	ILLINOIS FED. AID PROJECT			
	CONTRACT NO. 83714			

FINAL SUPERVISOR
DATE
BY
CHECKED
DATE
BY
APPROVED
DATE
BY

ORIGINAL SUPERVISOR
DATE
BY
CHECKED
DATE
BY
APPROVED
DATE
BY

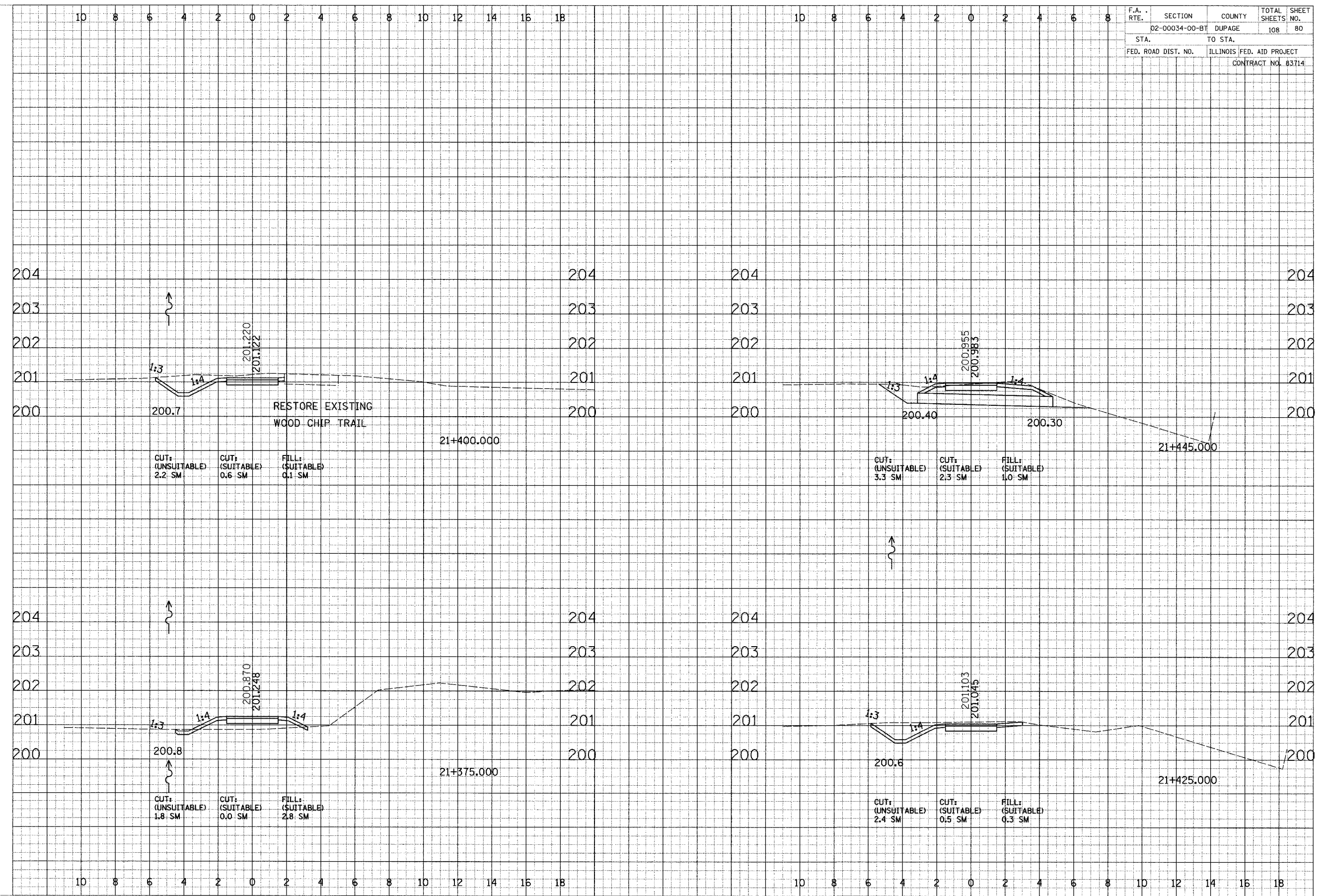

CROSS SECTIONS - SOUTH DUPAGE

F.A. RTE.	SECTION	COUNTY	TOTAL SHEETS	SHEET NO.
	02-00034-00-BT	DUPAGE	108	82
STA.	TO STA.			
FED. ROAD DIST. NO.	ILLINOIS FED. AID PROJECT		CONTRACT NO. 83714	

DATE	BY
REVISIONS	
NO.	DESCRIPTION

DATE	BY
REVISIONS	
NO.	DESCRIPTION

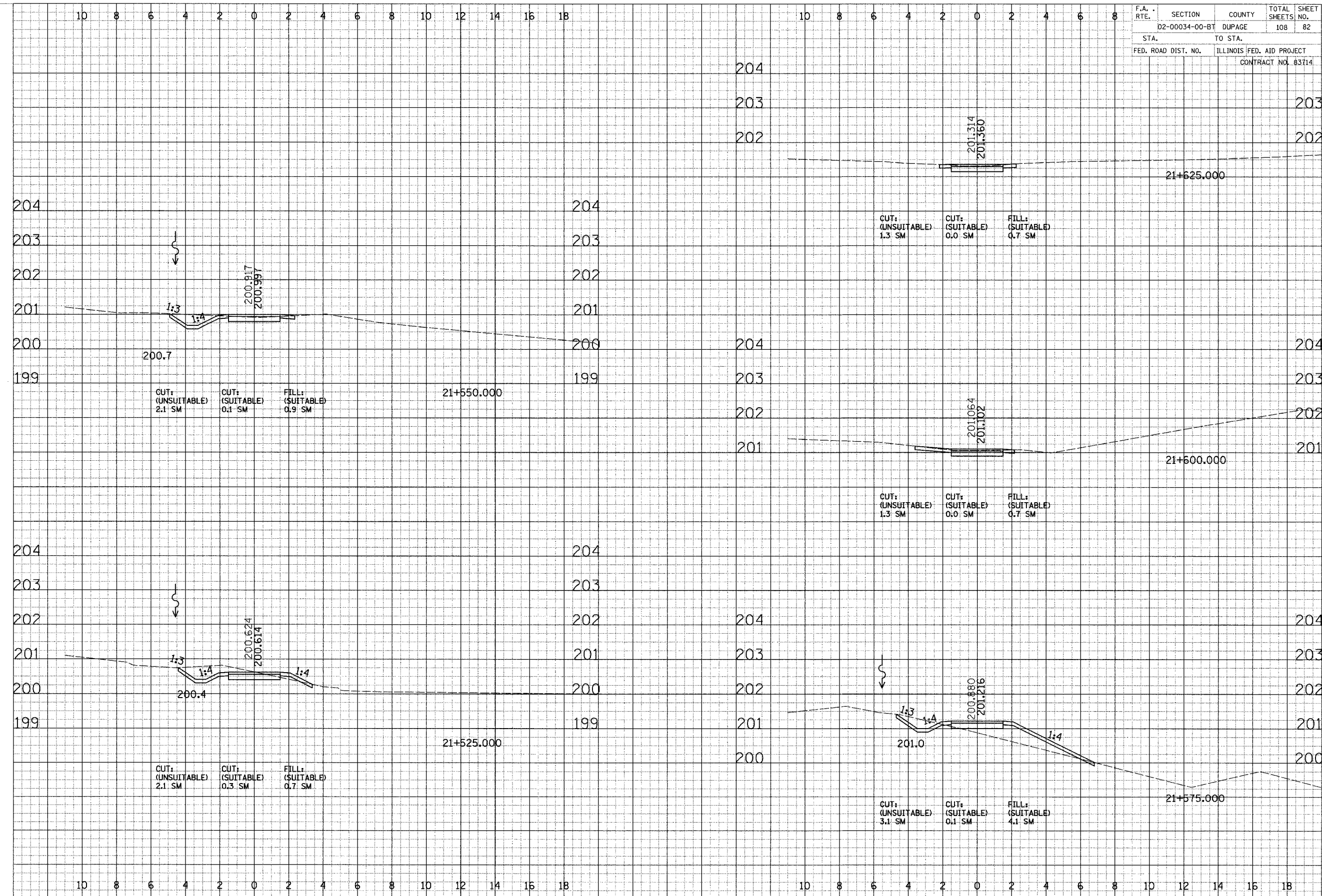

CROSS SECTIONS - SOUTH DUPAGE

F.A. RTE.	SECTION	COUNTY	TOTAL SHEETS	SHEET NO.
	02-00034-00-BT	DUPAGE	108	83
STA.	TO STA.			
FED. ROAD DIST. NO.	ILLINOIS FED. AID PROJECT		CONTRACT NO. 83T14	

FINAL SURVEY NOTE BOOK	REVISIONS	DATE

ORIGINAL SURVEY NOTE BOOK	REVISIONS	DATE

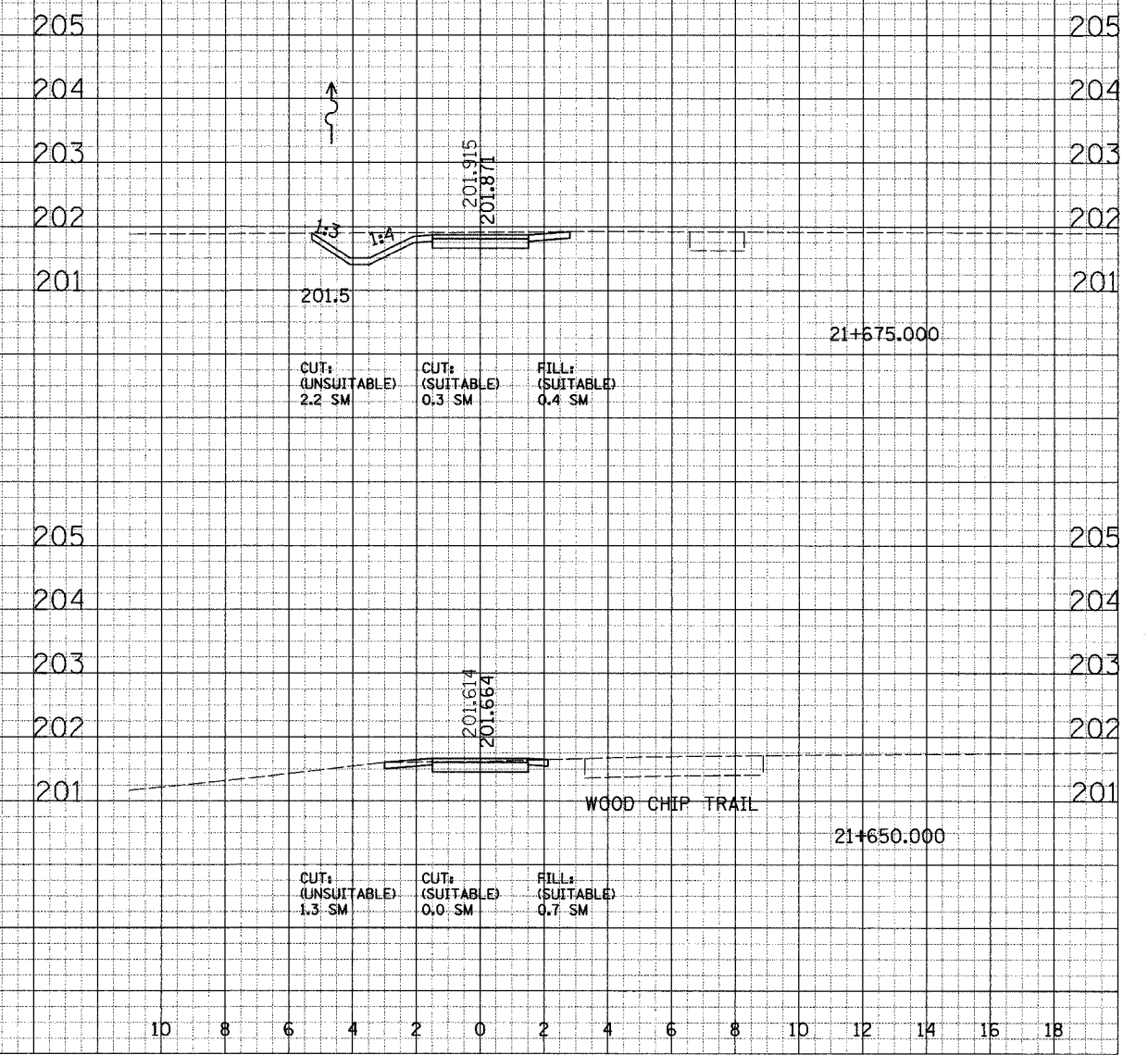

CROSS SECTIONS - SOUTH DUPAGE

F.A. RTE.	SECTION	COUNTY	TOTAL SHEETS	SHEET NO.
	02-00034-00-BT	DUPAGE	108	84
STA.	TO STA.			
FED. ROAD DIST. NO.	ILLINOIS FED. AID PROJECT			
CONTRACT NO. 83714				

FINAL SURVEY	DATE
BY	
REVISIONS	
NO. 1	
NO. 2	
NO. 3	
NO. 4	
NO. 5	
NO. 6	
NO. 7	
NO. 8	
NO. 9	
NO. 10	
NO. 11	
NO. 12	
NO. 13	
NO. 14	
NO. 15	
NO. 16	
NO. 17	
NO. 18	
NO. 19	
NO. 20	
NO. 21	
NO. 22	
NO. 23	
NO. 24	
NO. 25	
NO. 26	
NO. 27	
NO. 28	
NO. 29	
NO. 30	
NO. 31	
NO. 32	
NO. 33	
NO. 34	
NO. 35	
NO. 36	
NO. 37	
NO. 38	
NO. 39	
NO. 40	
NO. 41	
NO. 42	
NO. 43	
NO. 44	
NO. 45	
NO. 46	
NO. 47	
NO. 48	
NO. 49	
NO. 50	
NO. 51	
NO. 52	
NO. 53	
NO. 54	
NO. 55	
NO. 56	
NO. 57	
NO. 58	
NO. 59	
NO. 60	

ORIGINAL SURVEY	DATE
BY	
REVISIONS	
NO. 1	
NO. 2	
NO. 3	
NO. 4	
NO. 5	
NO. 6	
NO. 7	
NO. 8	
NO. 9	
NO. 10	
NO. 11	
NO. 12	
NO. 13	
NO. 14	
NO. 15	
NO. 16	
NO. 17	
NO. 18	
NO. 19	
NO. 20	
NO. 21	
NO. 22	
NO. 23	
NO. 24	
NO. 25	
NO. 26	
NO. 27	
NO. 28	
NO. 29	
NO. 30	
NO. 31	
NO. 32	
NO. 33	
NO. 34	
NO. 35	
NO. 36	
NO. 37	
NO. 38	
NO. 39	
NO. 40	
NO. 41	
NO. 42	
NO. 43	
NO. 44	
NO. 45	
NO. 46	
NO. 47	
NO. 48	
NO. 49	
NO. 50	
NO. 51	
NO. 52	
NO. 53	
NO. 54	
NO. 55	
NO. 56	
NO. 57	
NO. 58	
NO. 59	
NO. 60	

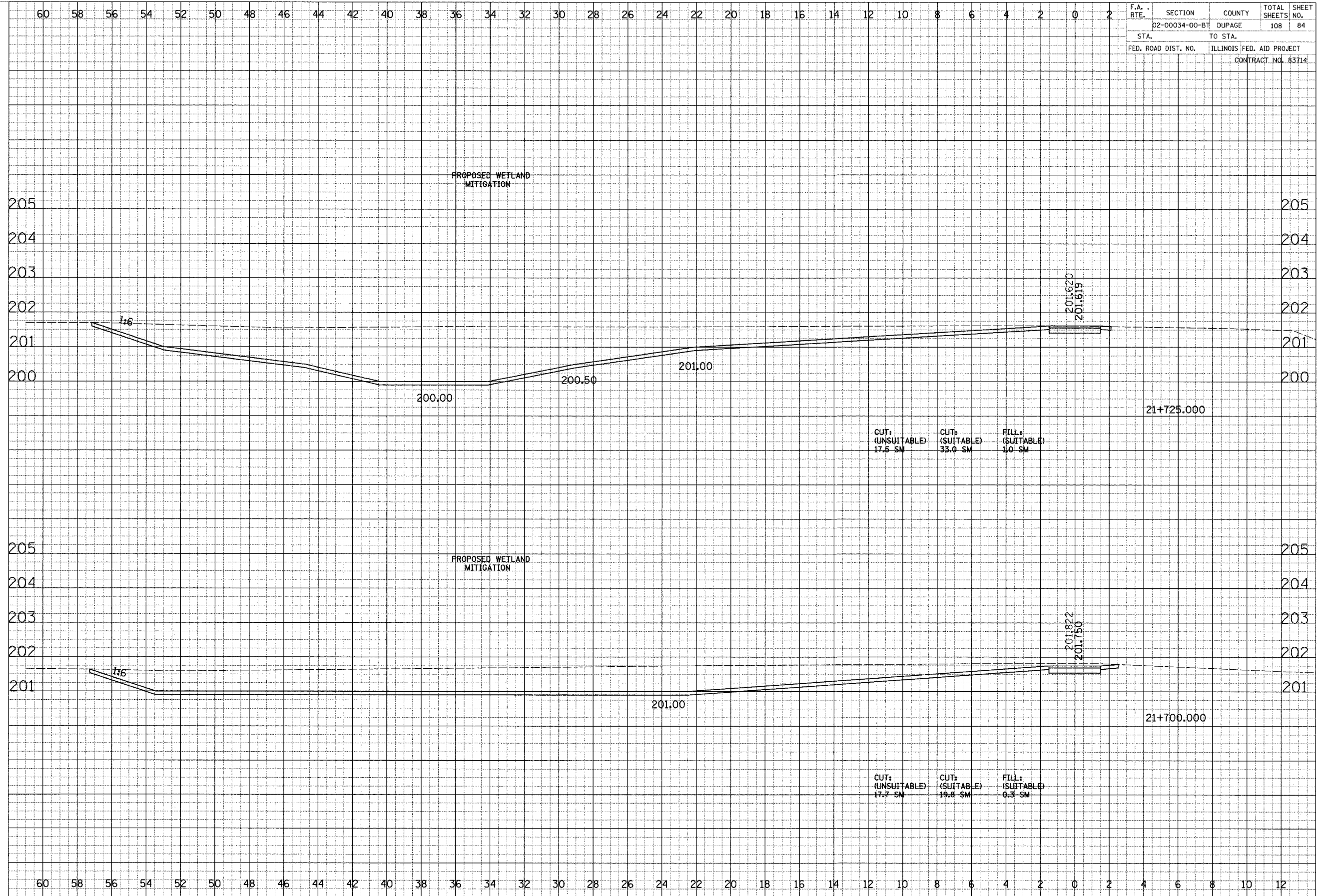

CROSS SECTIONS - SOUTH DUPAGE

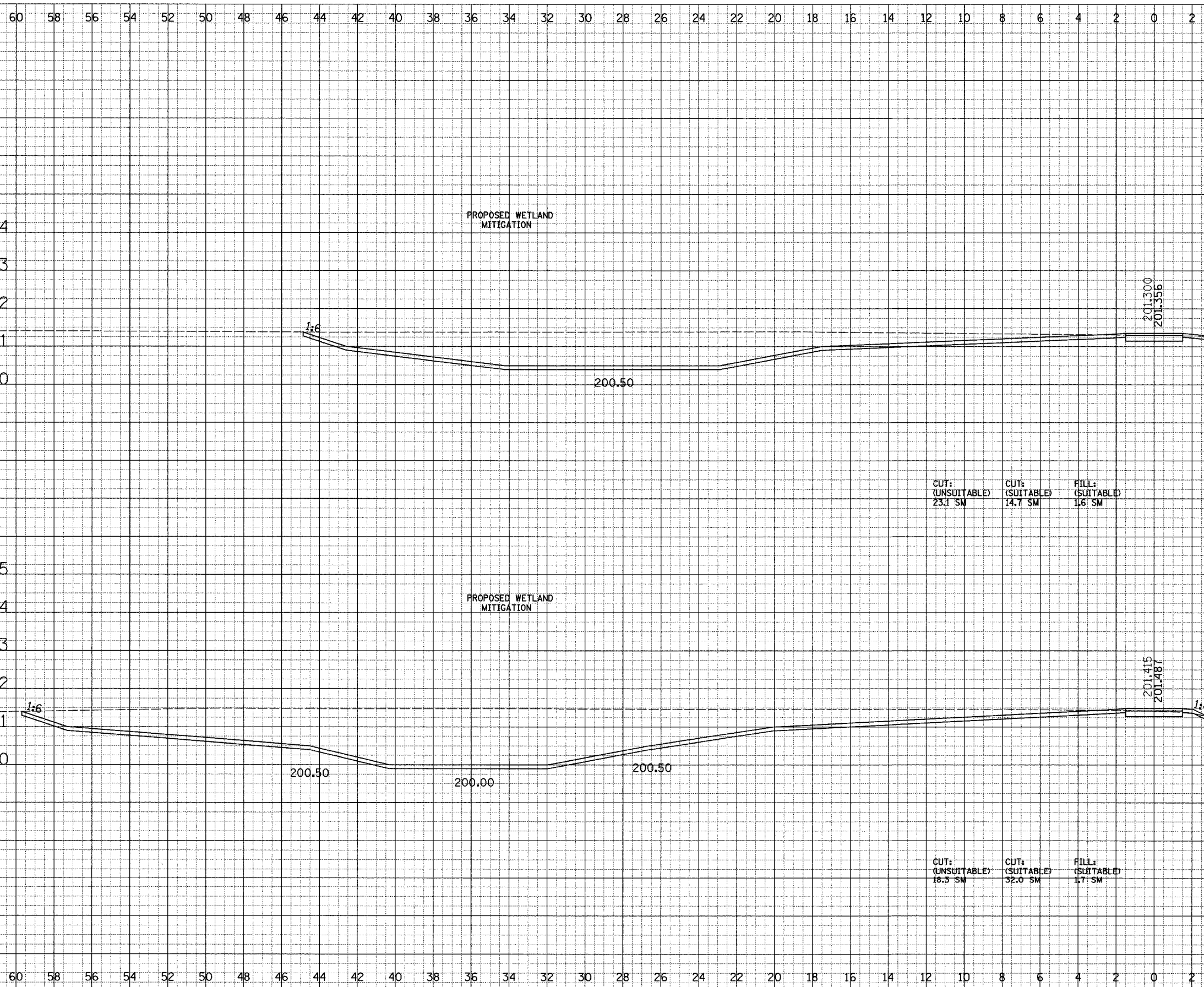

F.A. RTE.	SECTION	COUNTY	TOTAL SHEETS	SHEET NO.
	02-00034-00-BT	DUPAGE	108	85
STA.	TO STA.			
FED. ROAD DIST. NO.	ILLINOIS FED. AID PROJECT		CONTRACT NO. 83714	

DATE: _____ BY: _____
 FINISHED SURVEY PLOTTED AND CHECKED BY: _____
 NOTE BOOK NO. _____ AREA CHECKED: _____

DATE: _____ BY: _____
 FINISHED SURVEY PLOTTED AND CHECKED BY: _____
 NOTE BOOK NO. _____ AREA CHECKED: _____

CUT: (UNSUITABLE) 23.1 SM
 CUT: (SUITABLE) 14.7 SM
 FILL: (SUITABLE) 16 SM

CUT: (UNSUITABLE) 18.3 SM
 CUT: (SUITABLE) 32.0 SM
 FILL: (SUITABLE) 17 SM

CROSS SECTIONS - SOUTH DUPAGE

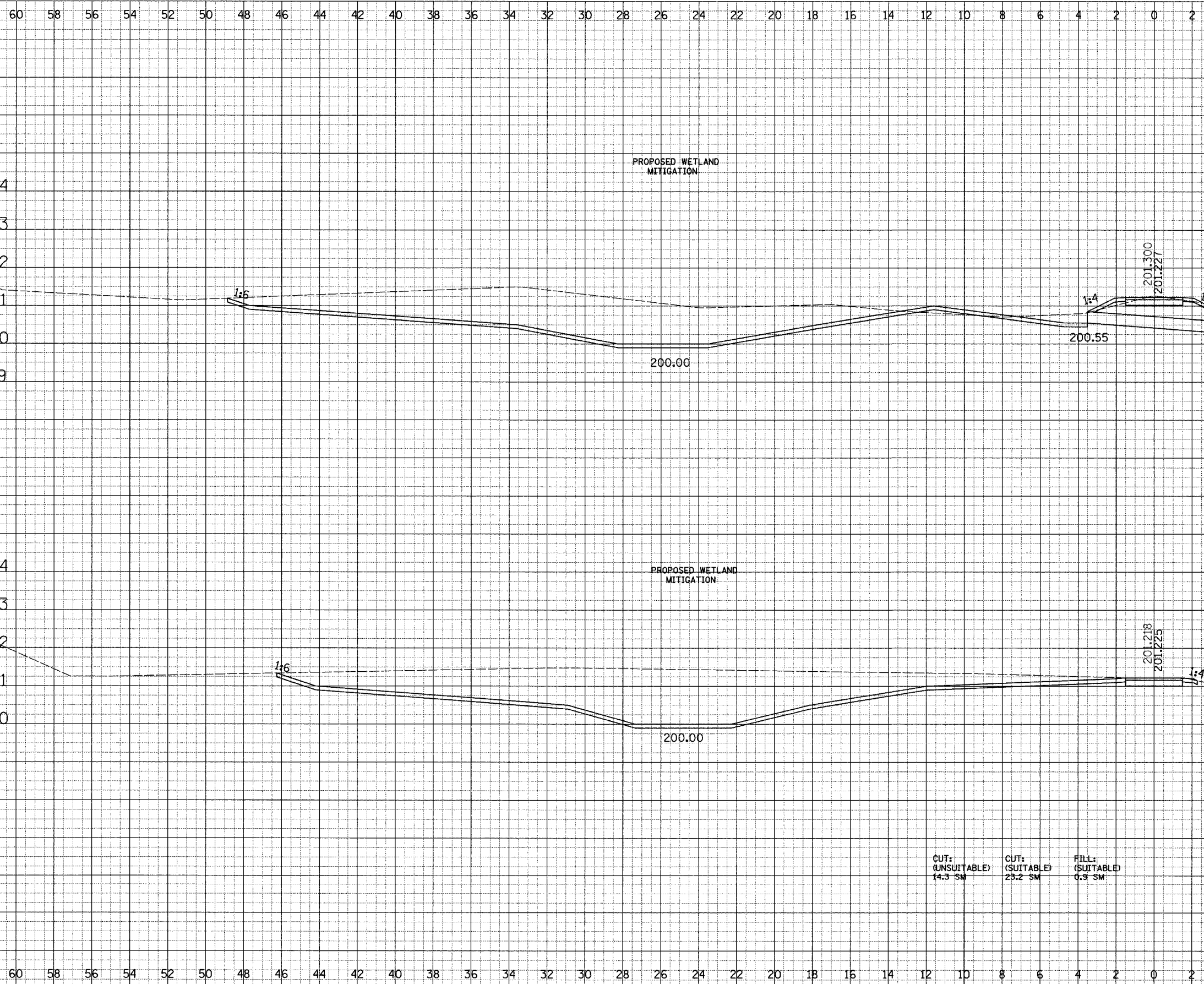

F.A. RTE.	SECTION	COUNTY	TOTAL SHEETS	SHEET NO.
	02-00034-00-BT	DUPAGE	108	86
STA.	TO STA.			
FED. ROAD DIST. NO.	ILLINOIS	FED. AID PROJECT		
CONTRACT NO. 83714				

FINAL SURVEY	SURVEYED	DATE
SHEET	PLOTTED	
NOTE BOOK	DATE	
NO.	AREAS CHECKED	

ORIGINAL SURVEY	SURVEYED	DATE
SHEET	PLOTTED	
NOTE BOOK	DATE	
NO.	AREAS CHECKED	

CUT: (UNSUITABLE) 14.3 SM
 CUT: (SUITABLE) 23.2 SM
 FILL: (SUITABLE) 6.9 SM

DATE	
BY	
DRIVING SURVEY	
PLANTED	
NOTE BOOK	
AREAS CHECKED	
NO.	
FINN	
SURV	
PLANT	
NOTE	
BOOK	
AREAS	
CHECKED	
NO.	

DATE	
BY	
DRIVING SURVEY	
PLANTED	
NOTE BOOK	
AREAS CHECKED	
NO.	
FINN	
SURV	
PLANT	
NOTE	
BOOK	
AREAS	
CHECKED	
NO.	

F.A. RTE.	SECTION	COUNTY	TOTAL SHEETS	SHEET NO.
	02-00034-00-BT	DUPAGE	108	87
STA.	TO STA.			
FED. ROAD DIST. NO.	ILLINOIS	FED. AID PROJECT	CONTRACT NO. 83714	

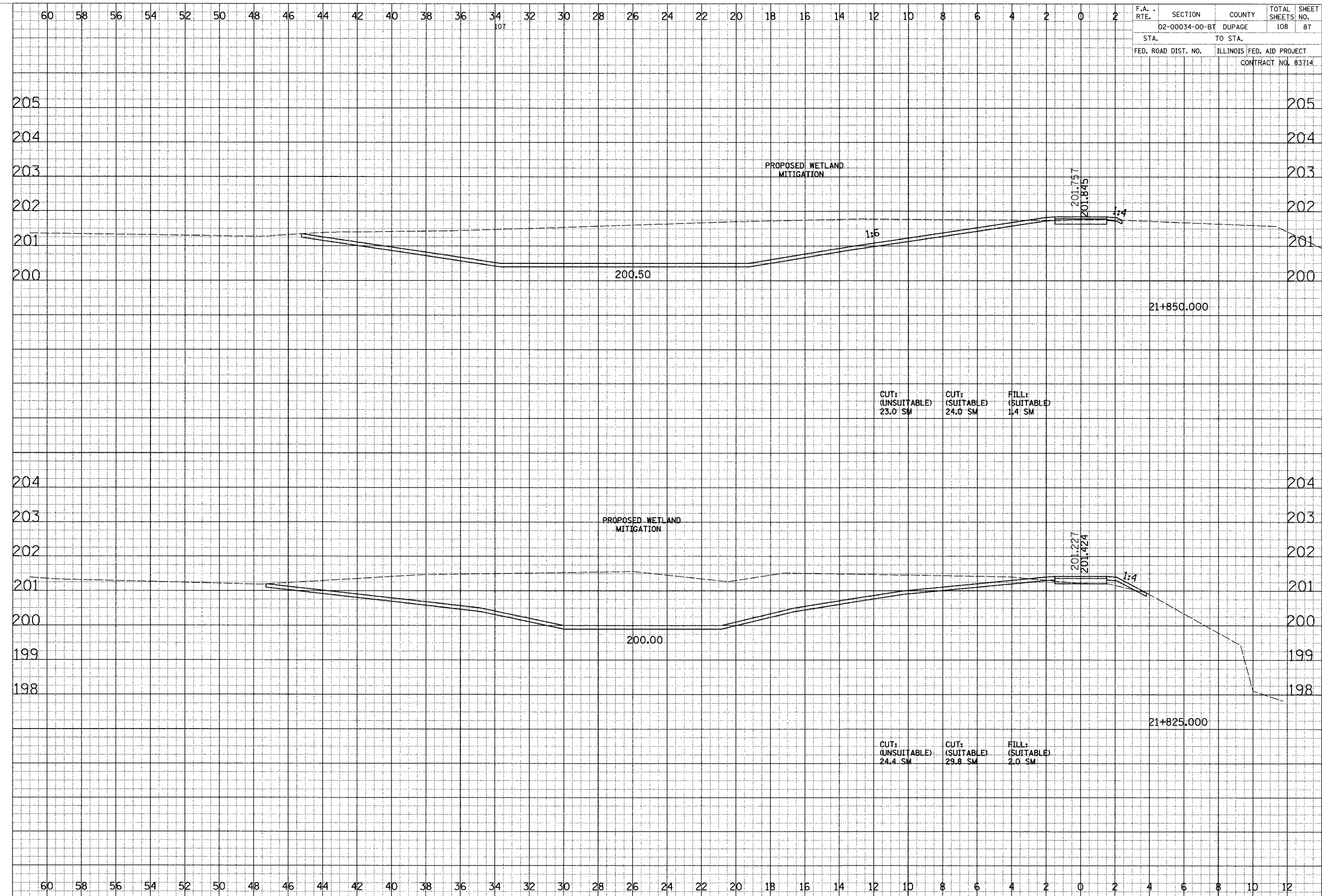

CROSS SECTIONS - SOUTH DUPAGE

F.A. RTE.	SECTION	COUNTY	TOTAL SHEETS	SHEET NO.
	02-00034-00-BT	DUPAGE	108	88
STA.	TO STA.			
FED. ROAD DIST. NO.	ILLINOIS	FED. AID PROJECT	CONTRACT NO. 83714	

FINAL SURVEY PLOTTED DATE
 NOTE BOOK AREAS CHECKED

ORIGINAL SURVEY PLOTTED DATE
 NOTE BOOK AREAS CHECKED

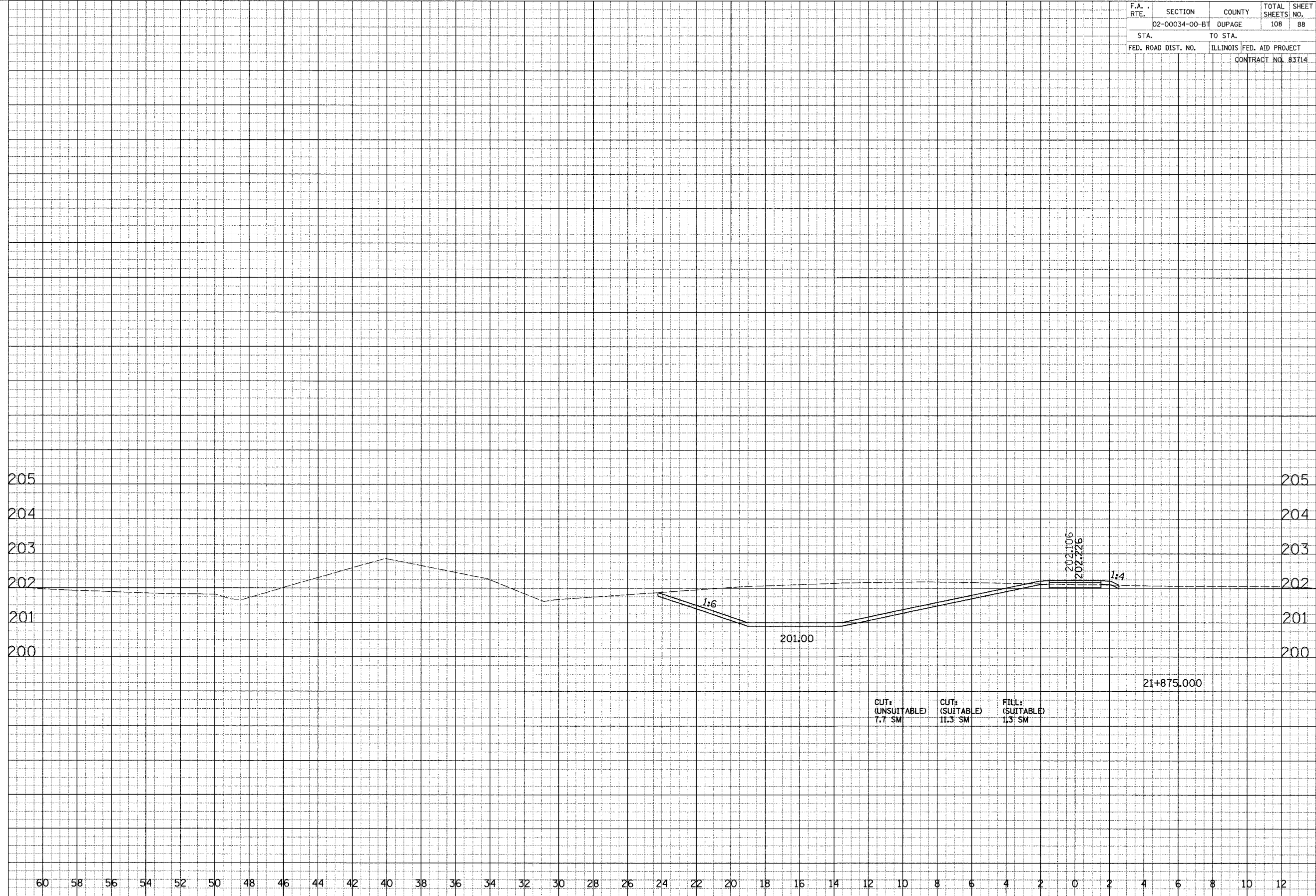

CROSS SECTIONS - SOUTH DUPAGE

F.A. RTE.	SECTION	COUNTY	TOTAL SHEETS	SHEET NO.
02-00034-00-BT	DUPAGE		108	89
STA.		TO STA.		
FED. ROAD DIST. NO.		ILLINOIS FED. AID PROJECT		
CONTRACT NO. 83714				

FINAL SURVEY	SURVEYED	DATE
NOTE BOOK	PLOTTED	
NO. AREAS CHECKED	BY	

ORIGINAL SURVEY	SURVEYED	DATE
NOTE BOOK	PLOTTED	
NO. AREAS CHECKED	BY	

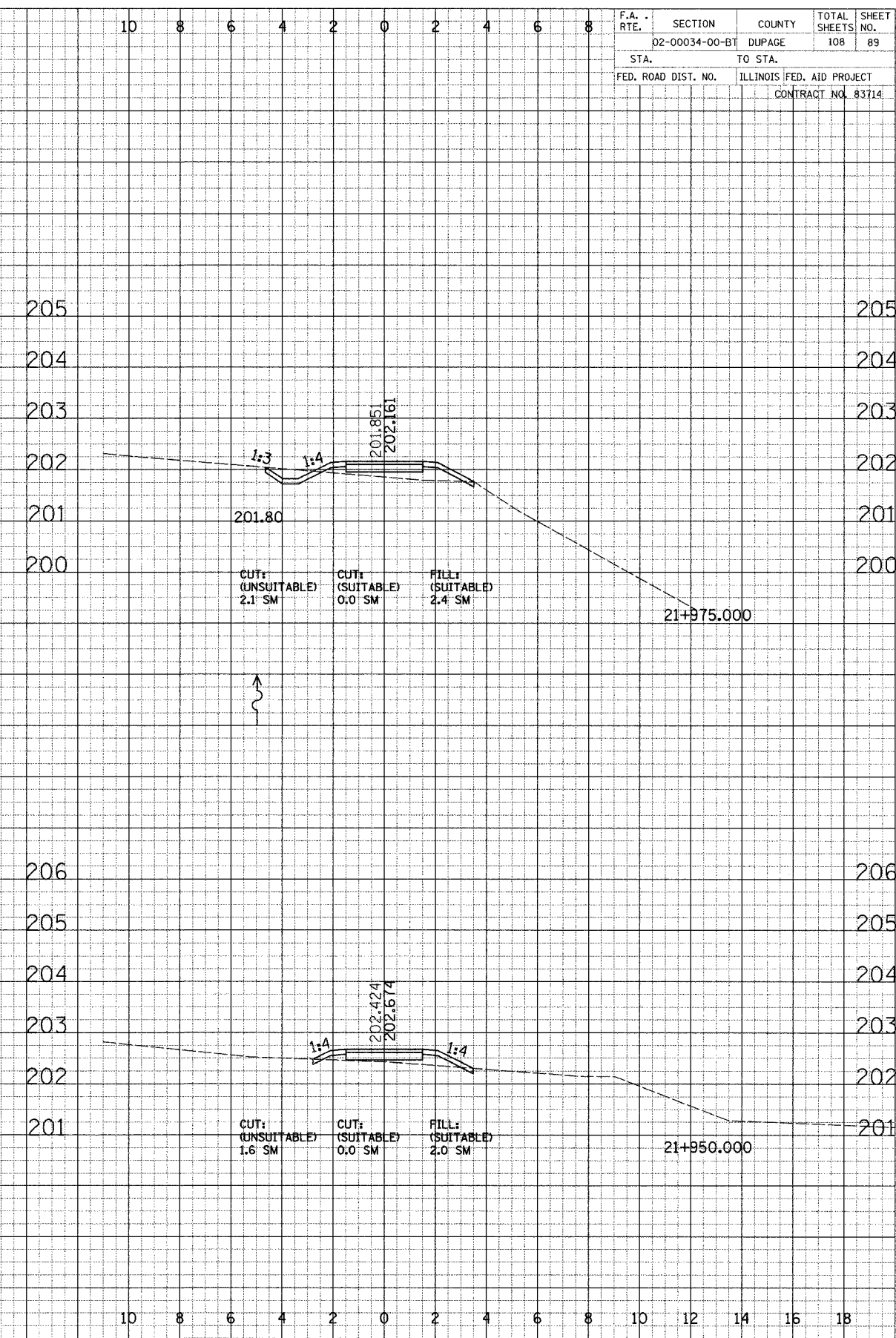
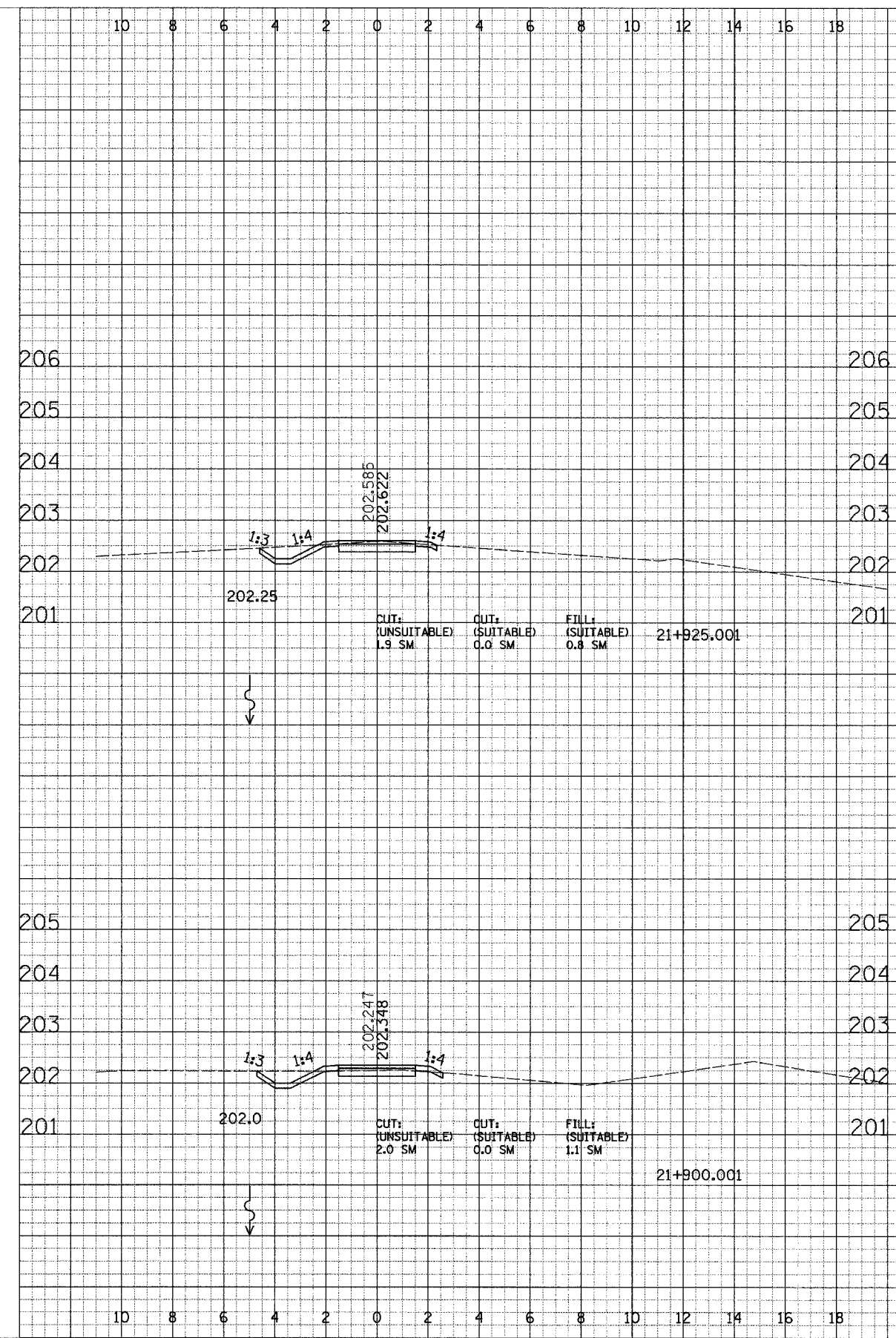

CROSS SECTIONS - SOUTH DUPAGE

F.A. RTE.	SECTION	COUNTY	TOTAL SHEETS	SHEET NO.
02-00034-00-BT	DUPAGE	DUPAGE	108	90
STA.		TO STA.		
FED. ROAD DIST. NO.		ILLINOIS FED. AID PROJECT		
CONTRACT NO. 83714				

FINAL SURVEY
 CHECKED BY
 DATE

ORIGINAL SURVEY
 CHECKED BY
 DATE

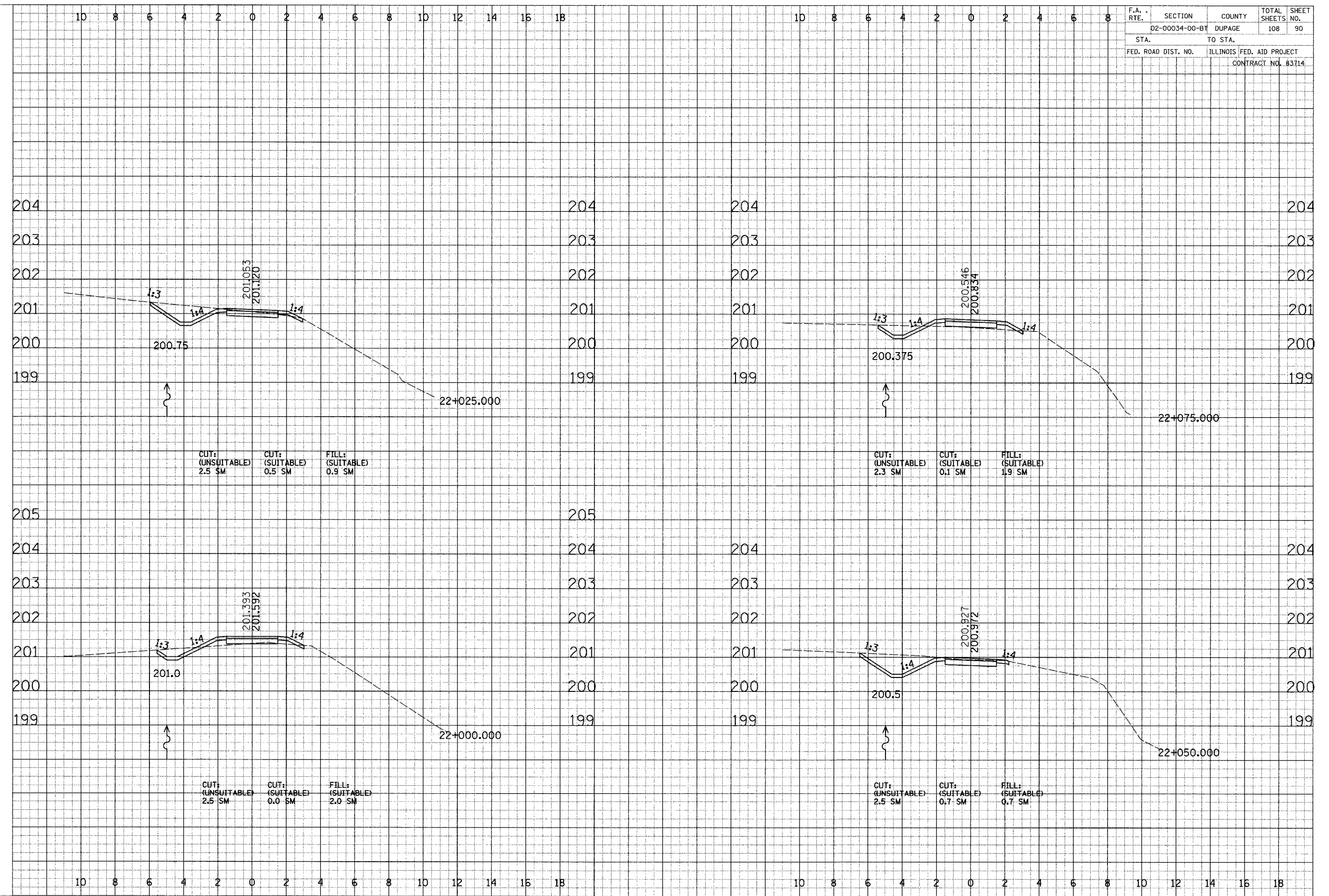

CROSS SECTIONS - SOUTH DUPAGE

FINAL SURVEY NOTE BOOK NO. _____
 SURVEYED BY _____ DATE _____
 PLOTTED BY _____ DATE _____
 AREAS CHECKED _____

ORIGINAL SURVEY NOTE BOOK NO. _____
 SURVEYED BY _____ DATE _____
 PLOTTED BY _____ DATE _____
 AREAS CHECKED _____

F.A. RTE.	SECTION	COUNTY	TOTAL SHEETS	SHEET NO.
	02-00034-00-BT	DUPAGE	108	91
STA.		TO STA.		
FED. ROAD DIST. NO.	ILLINOIS FED. AID PROJECT	CONTRACT NO. 83714		

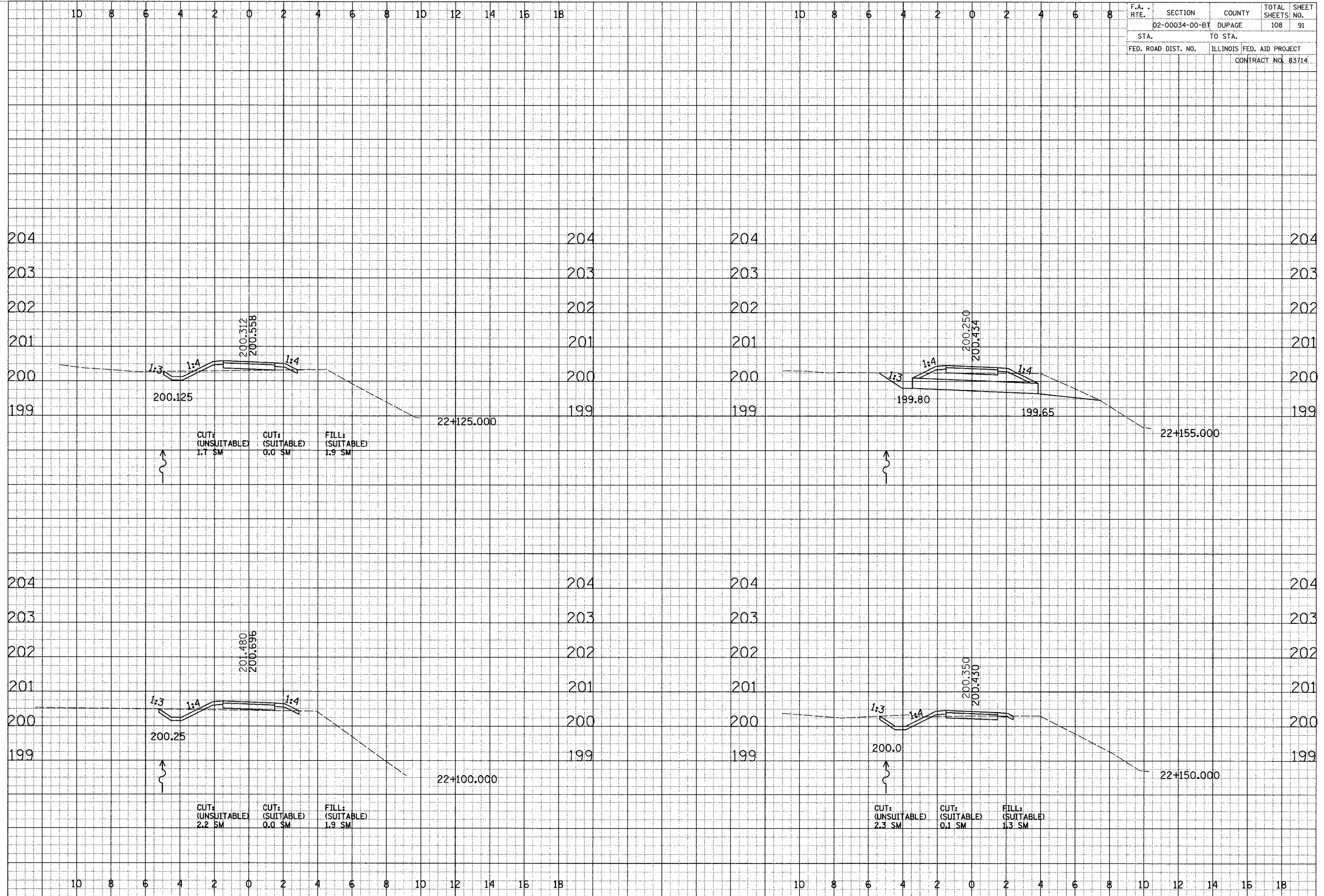

CROSS SECTIONS - SOUTH DUPAGE

F.A. RTE.	SECTION	COUNTY	TOTAL SHEETS	SHEET NO.
	02-00034-00-BT	DUPAGE	108	92
STA.	TO STA.			
FED. ROAD DIST. NO.	ILLINOIS	FED. AID PROJECT		
	CONTRACT NO. 83714			

FINAL SURVEY DRAWING
 SURVEYED BY: _____
 PLOTTED BY: _____
 NOTE BOOK NO. _____
 AREAS CHECKED: _____

ORIGINAL SURVEY DRAWING
 SURVEYED BY: _____
 PLOTTED BY: _____
 NOTE BOOK NO. _____
 AREAS CHECKED: _____

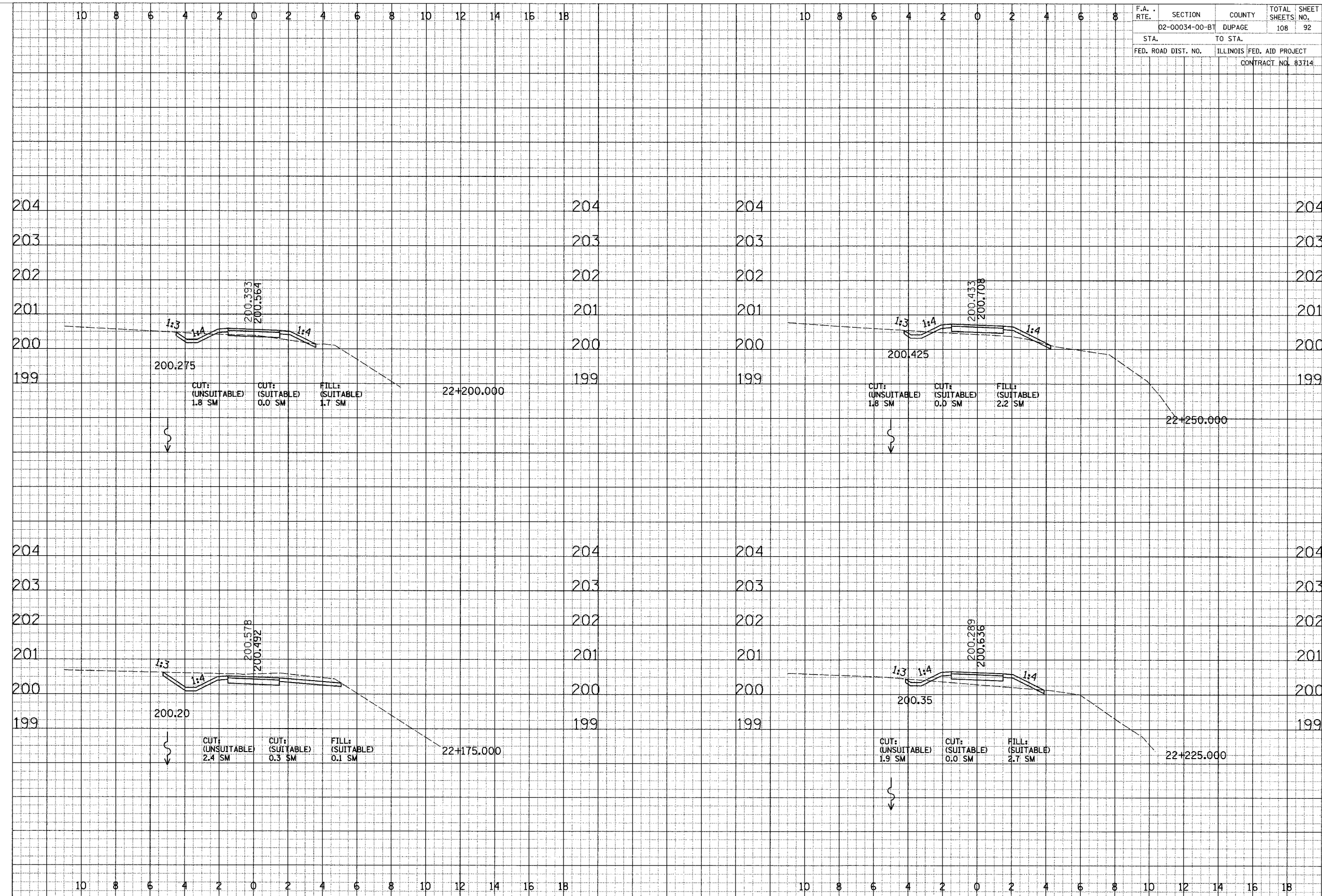

CROSS SECTIONS - SOUTH DUPAGE

FINAL SURVEY PLOTTED DATE
 SURVEY PLOTTED DATE
 NOTE BOOK NO.
 AREAS CHECKED

ORIGINAL SURVEY PLOTTED DATE
 SURVEY PLOTTED DATE
 NOTE BOOK NO.
 AREAS CHECKED

F.A. RTE.	SECTION	COUNTY	TOTAL SHEETS	SHEET NO.
	02-00034-00-BT	DUPAGE	108	94
STA.	TO STA.			
FED. ROAD DIST. NO.	ILLINOIS FED. AID PROJECT			
CONTRACT NO. 83714				

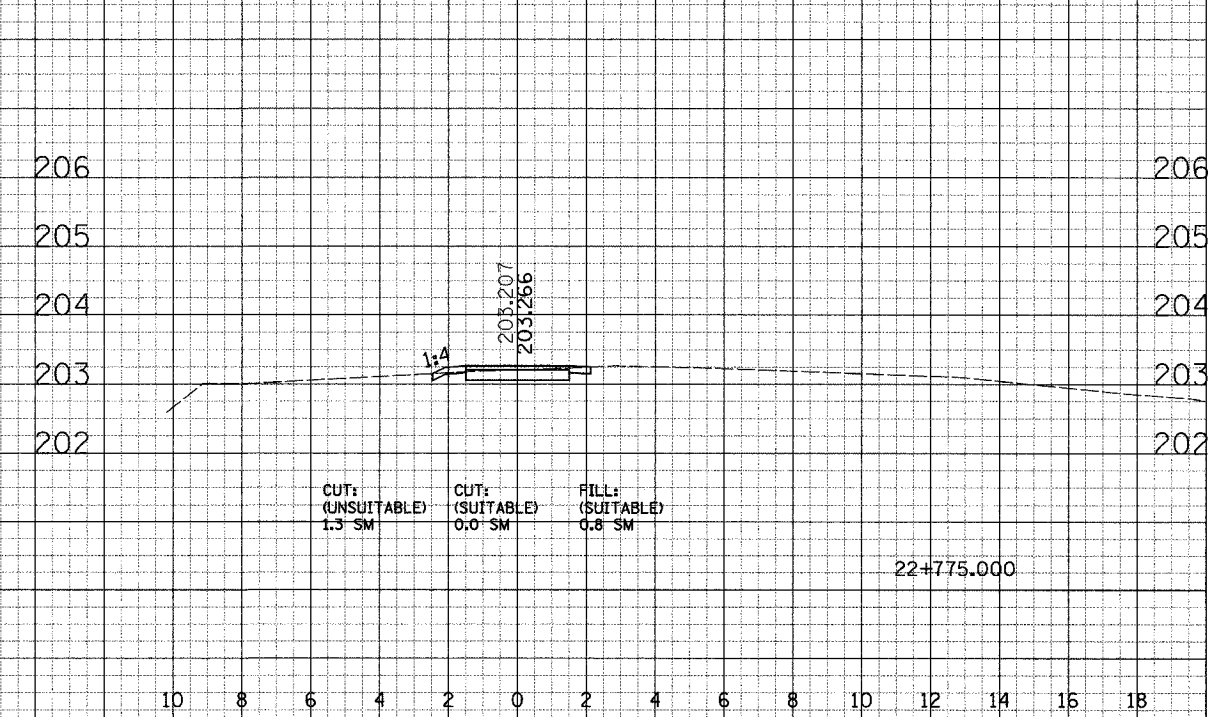
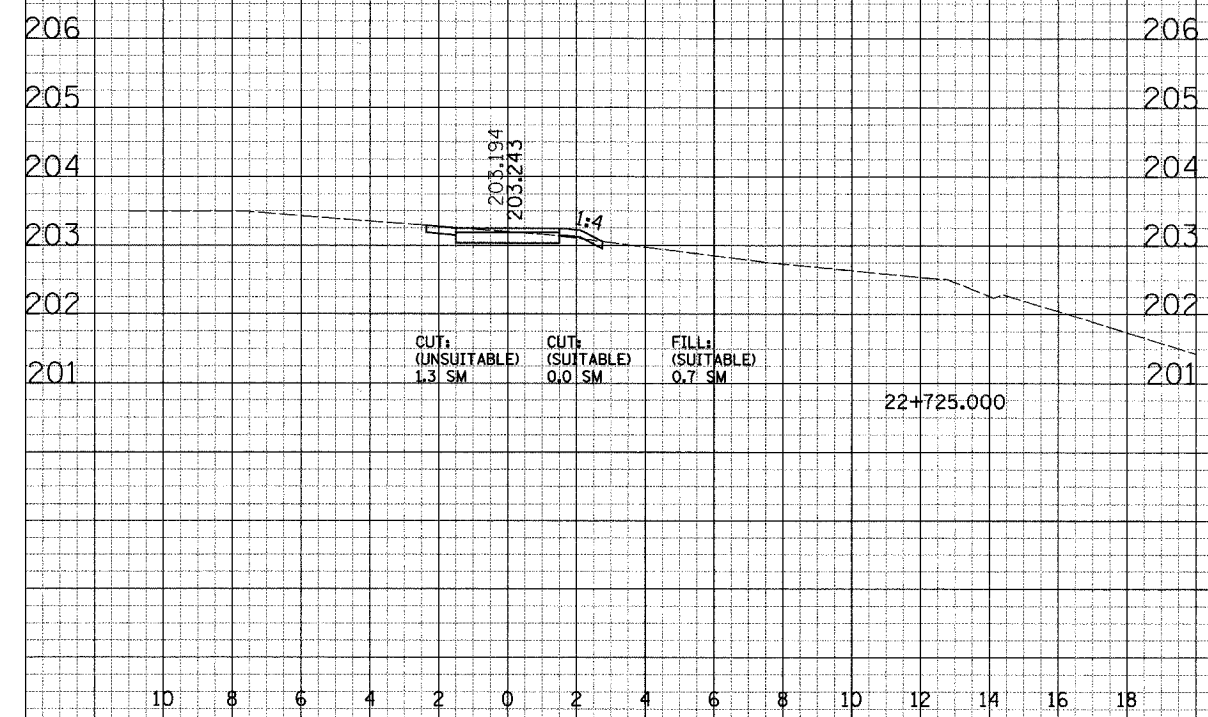
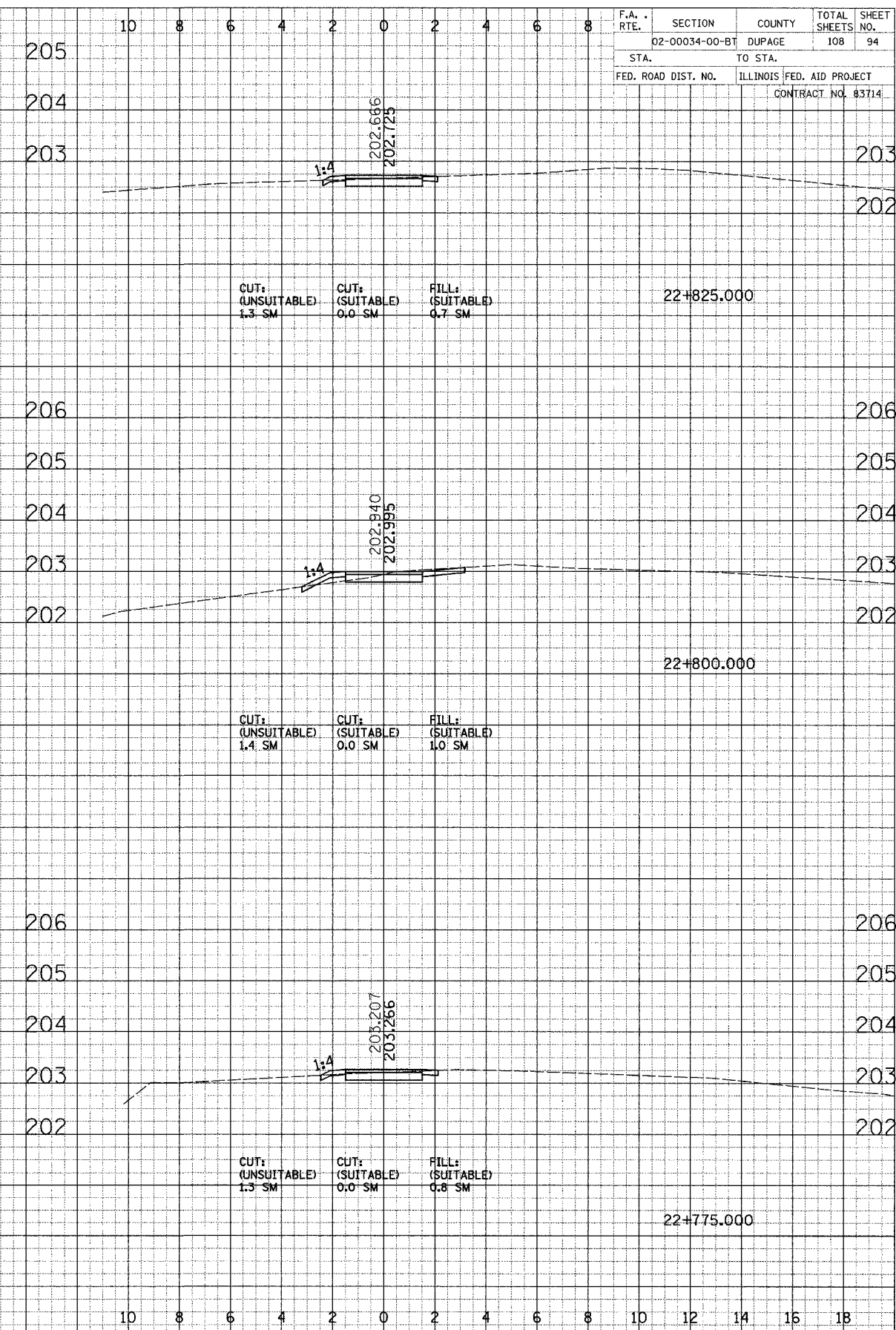
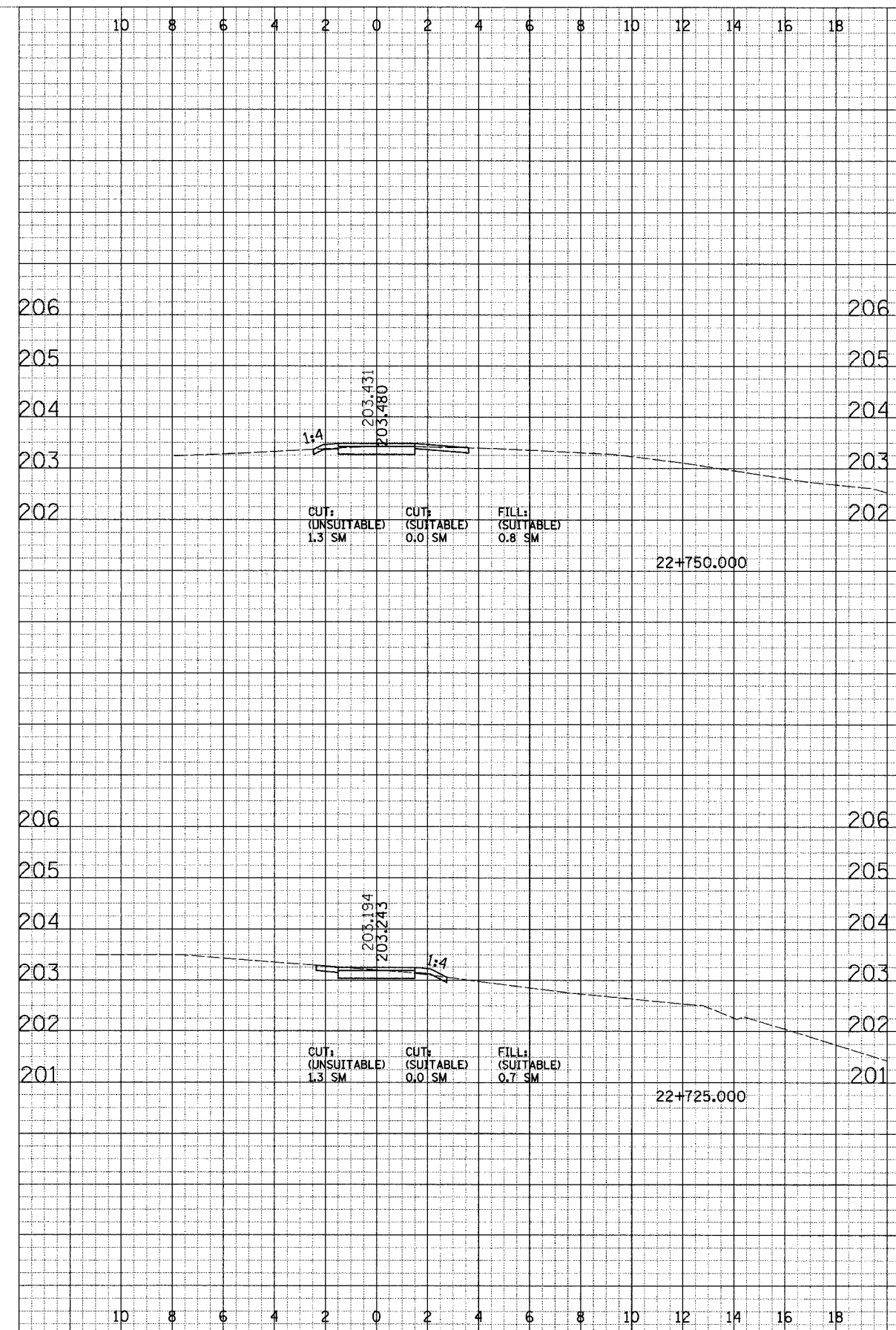

CROSS SECTIONS - SOUTH DUPAGE

F.A. RTE.	SECTION	COUNTY	TOTAL SHEETS	SHEET NO.
	02-00034-00-BT	DUPAGE	108	95
STA.	TO STA.			
FED. ROAD DIST. NO.	ILLINOIS	FED. AID PROJECT	CONTRACT NO. 83714	

FINAL SURVEY
NOTE BOOK
AREAS CHECKED

ORIGINAL SURVEY
NOTE BOOK
AREAS CHECKED

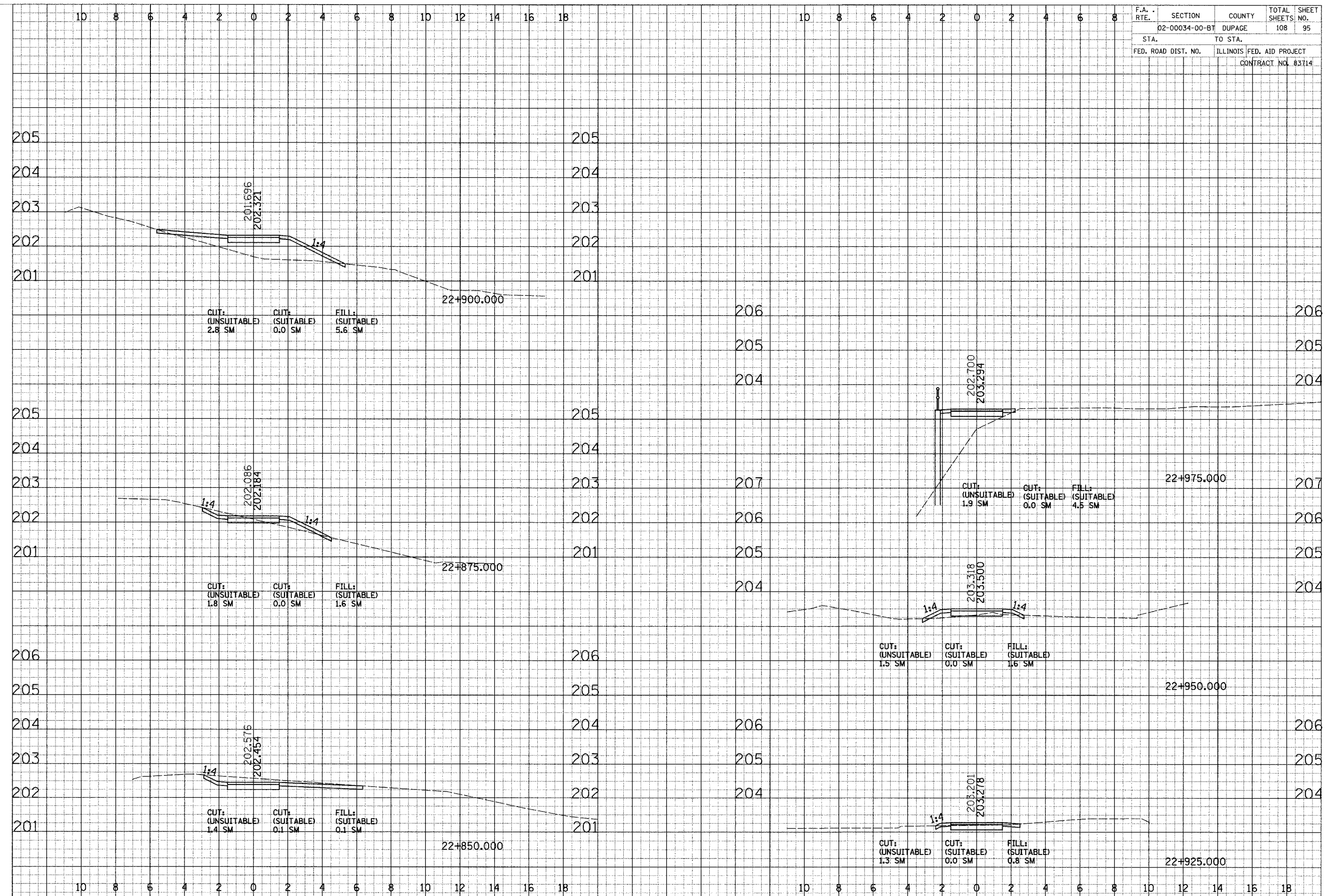

CROSS SECTIONS - SOUTH DUPAGE

FINN	SURVEYED	BY	DATE
SURVEY	PLOTTED		
NOTE BOOK	DATE		
NO.	AREAS CHECKED		

ORIGINAL	SURVEYED	BY	DATE
SURVEY	PLOTTED		
NOTE BOOK	DATE		
NO.	AREAS CHECKED		

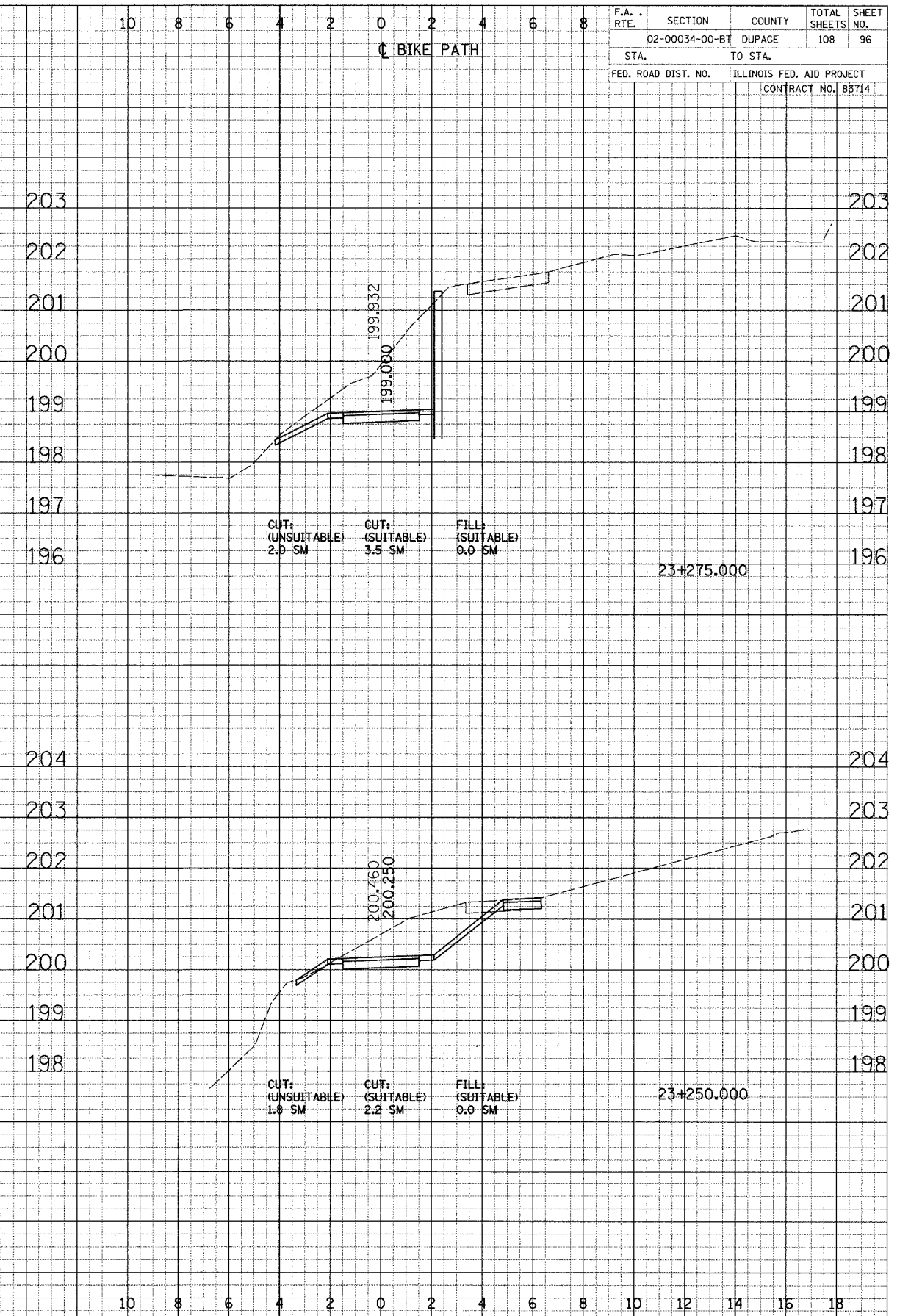
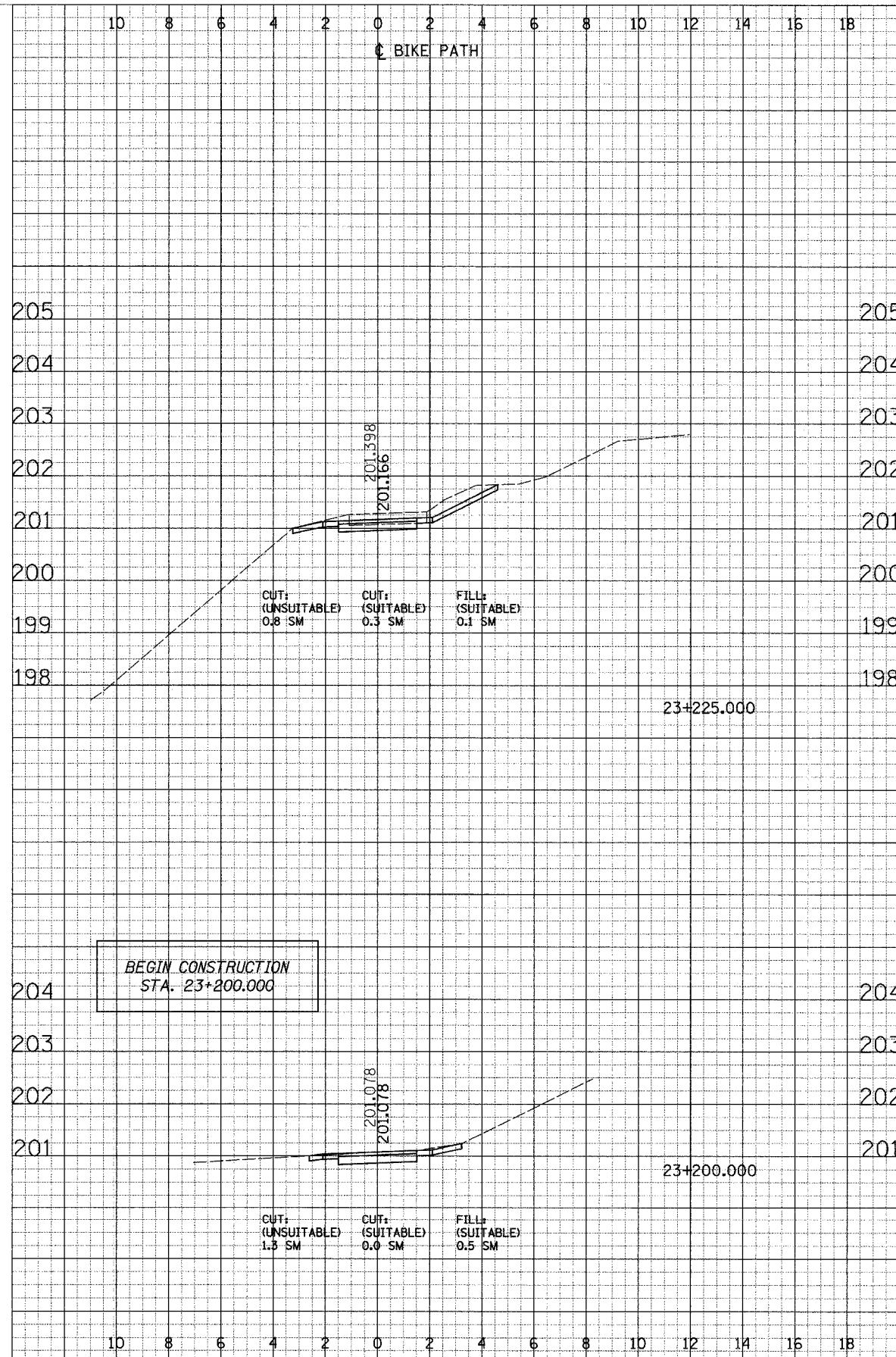

F.A. RTE.	SECTION	COUNTY	TOTAL SHEETS	SHEET NO.
	02-00034-00-BT	DUPAGE	108	96
STA.	TO STA.			
FED. ROAD DIST. NO.	ILLINOIS	FED. AID PROJECT	CONTRACT NO. 83714	

CROSS SECTIONS - OAKBROOK

DATE: _____
 BY: _____
 SURVEYED _____
 PLOTTED _____
 FINAL _____
 SURVEY _____
 NOTE BOOK _____
 NO. _____
 AREAS CHECKED _____

DATE: _____
 BY: _____
 SURVEYED _____
 PLOTTED _____
 ORIGINAL _____
 SURVEY _____
 NOTE BOOK _____
 NO. _____
 AREAS CHECKED _____

F.A. RTE.	SECTION	COUNTY	TOTAL SHEETS	SHEET NO.
	02-00034-00-BT	DUPAGE	108	97
STA.	TO STA.			
FED. ROAD DIST. NO.	ILLINOIS FED. AID PROJECT CONTRACT NO. 83714			

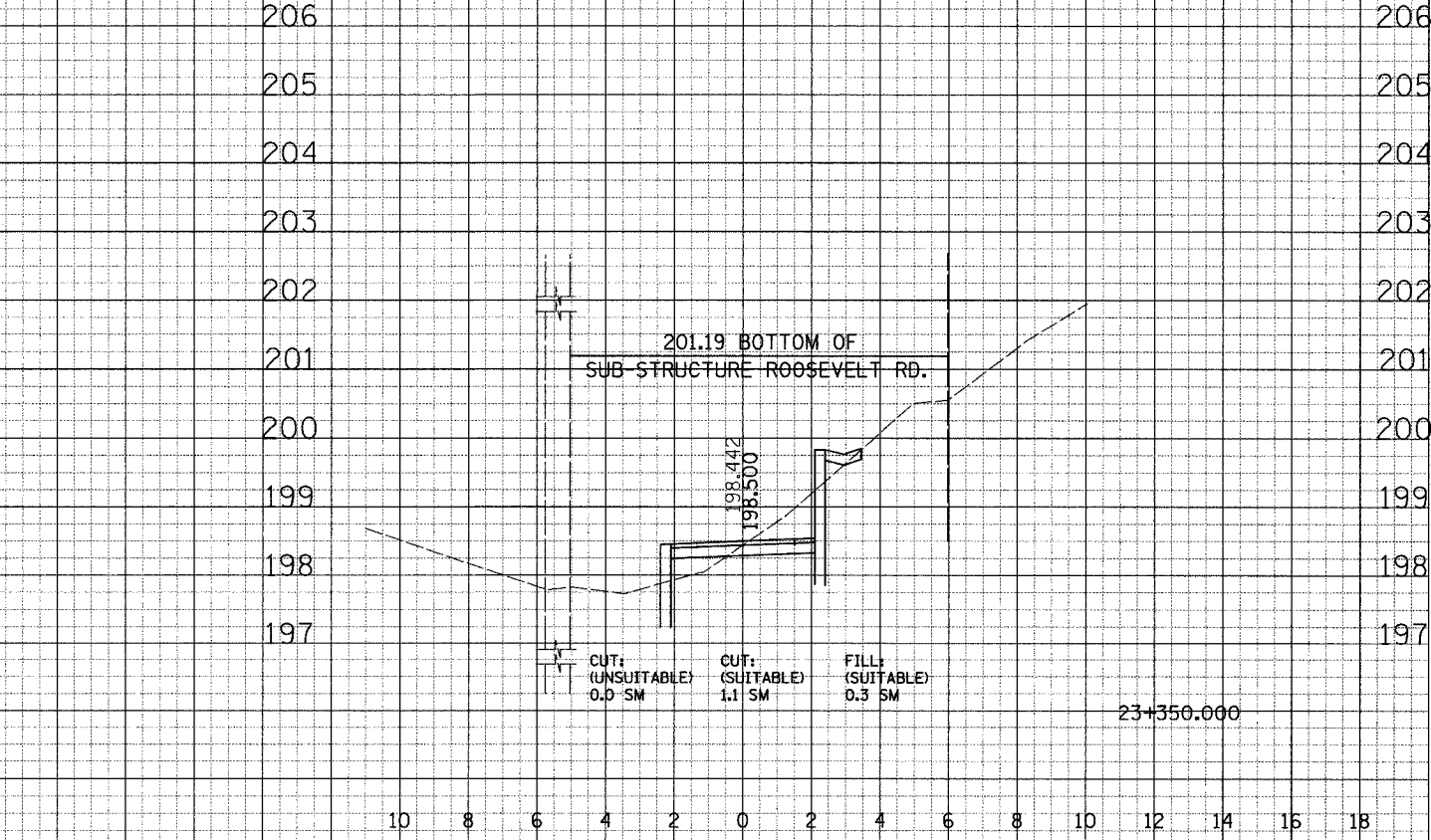
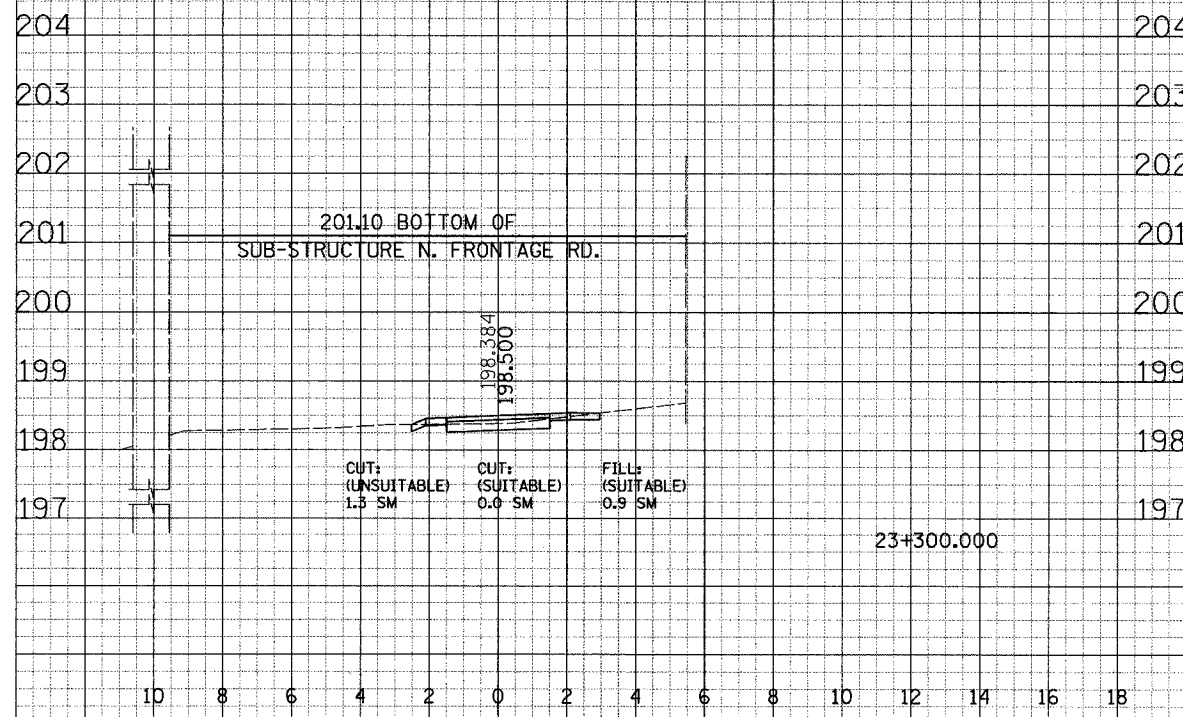
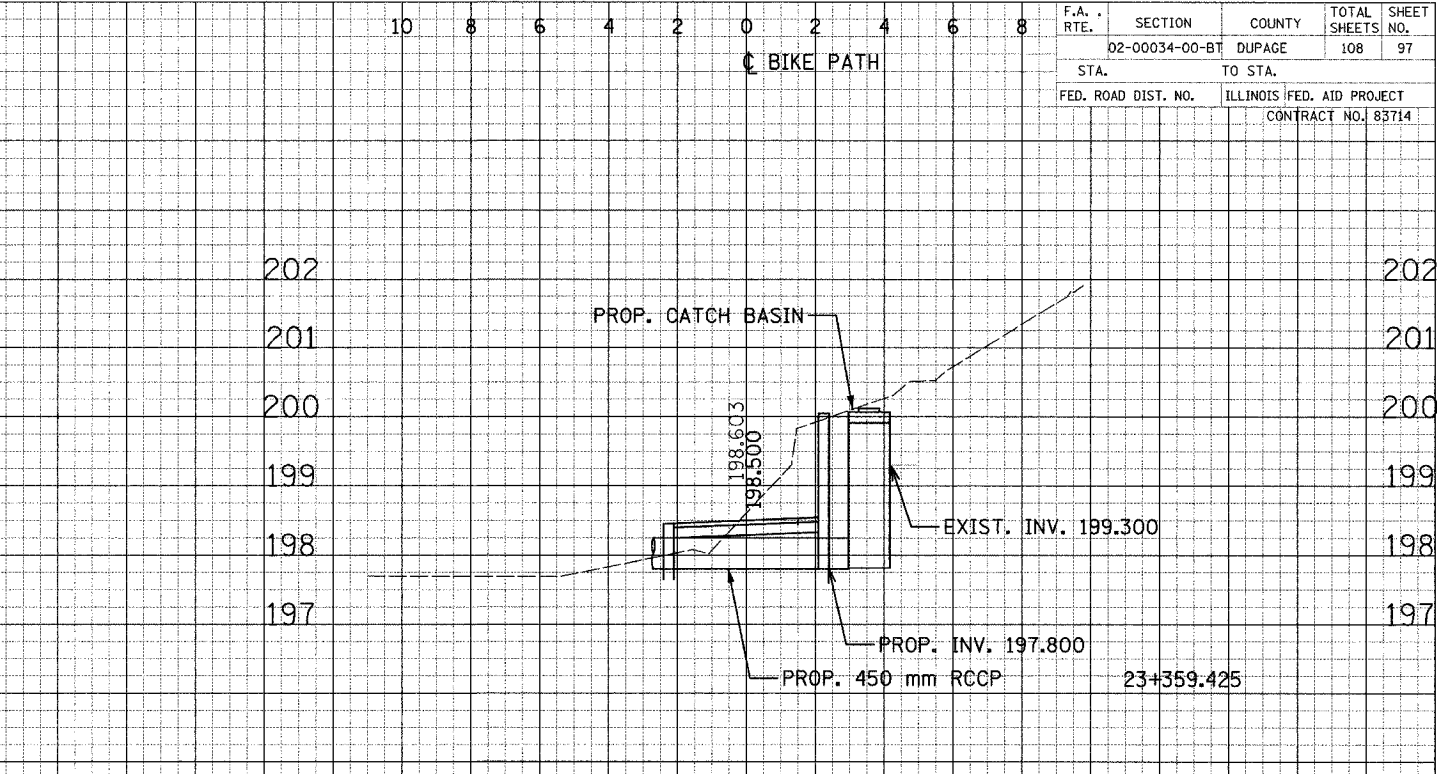
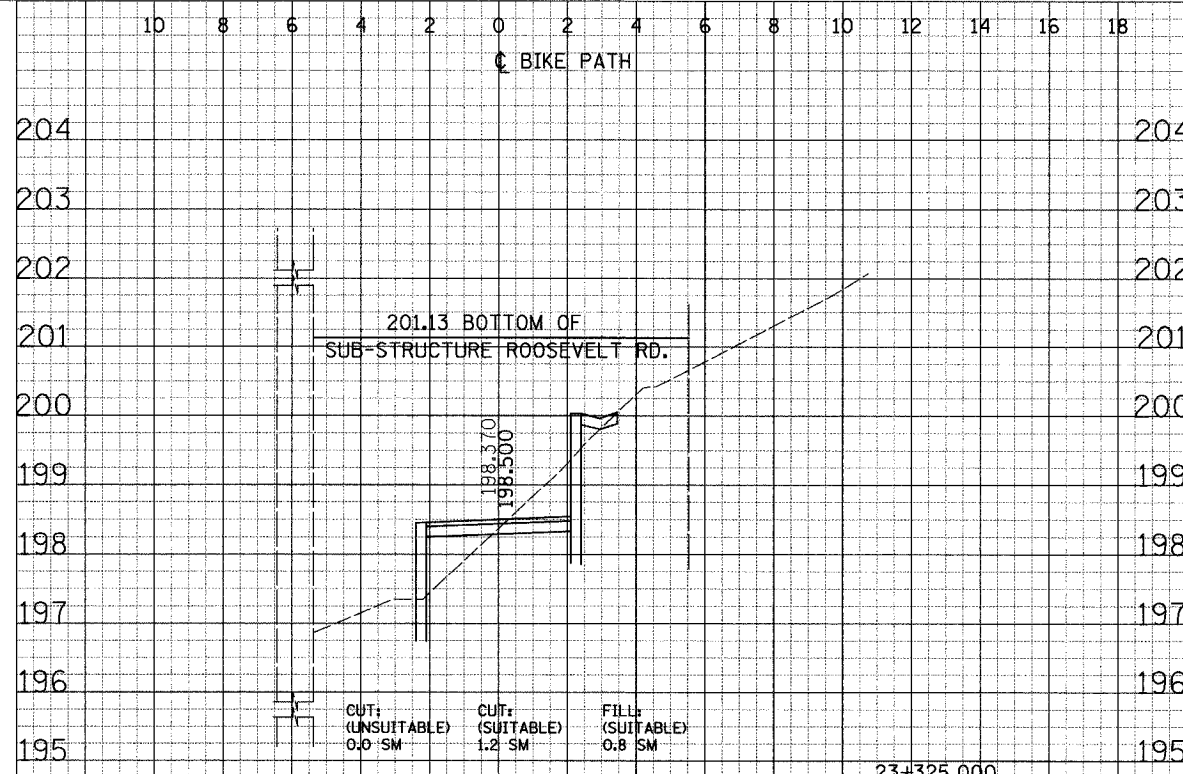

F.A. RTE.	SECTION	COUNTY	TOTAL SHEETS	SHEET NO.
	02-00034-00-BT	DUPAGE	108	98
STA.	TO STA.			
FED. ROAD DIST. NO.	ILLINOIS	FED. AID PROJECT	CONTRACT NO. 83714	

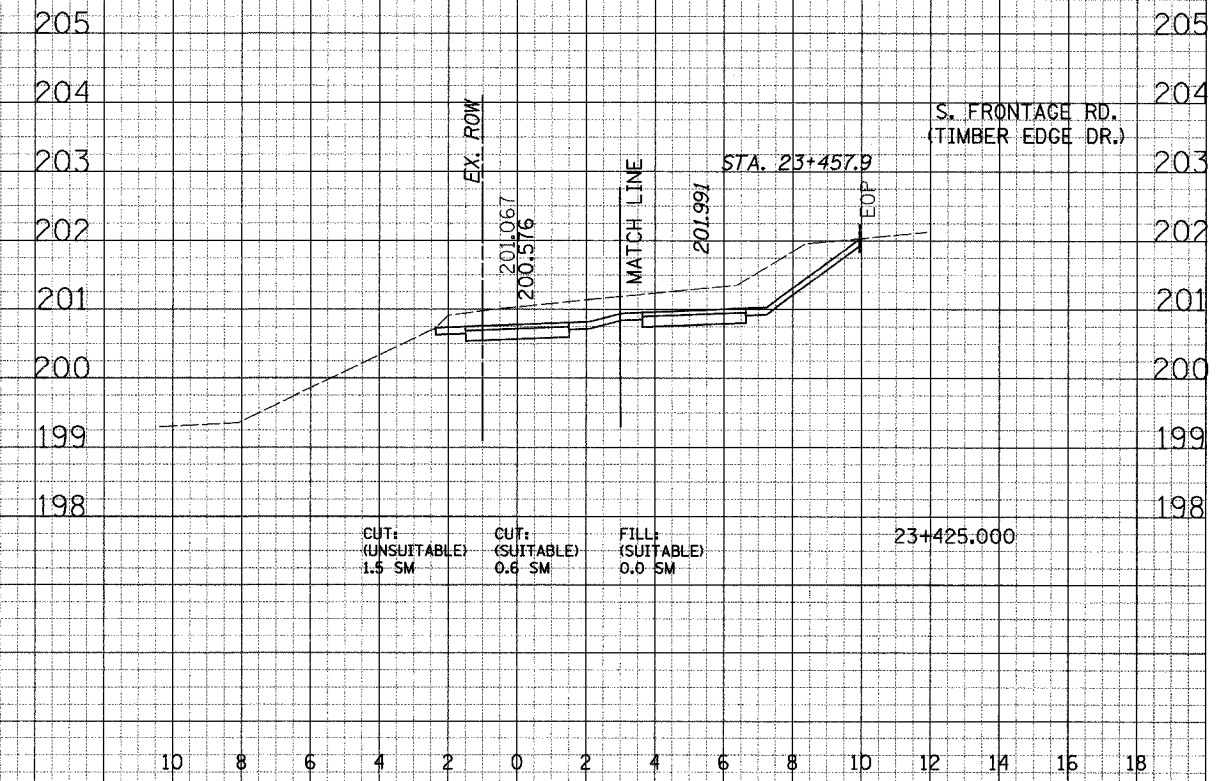
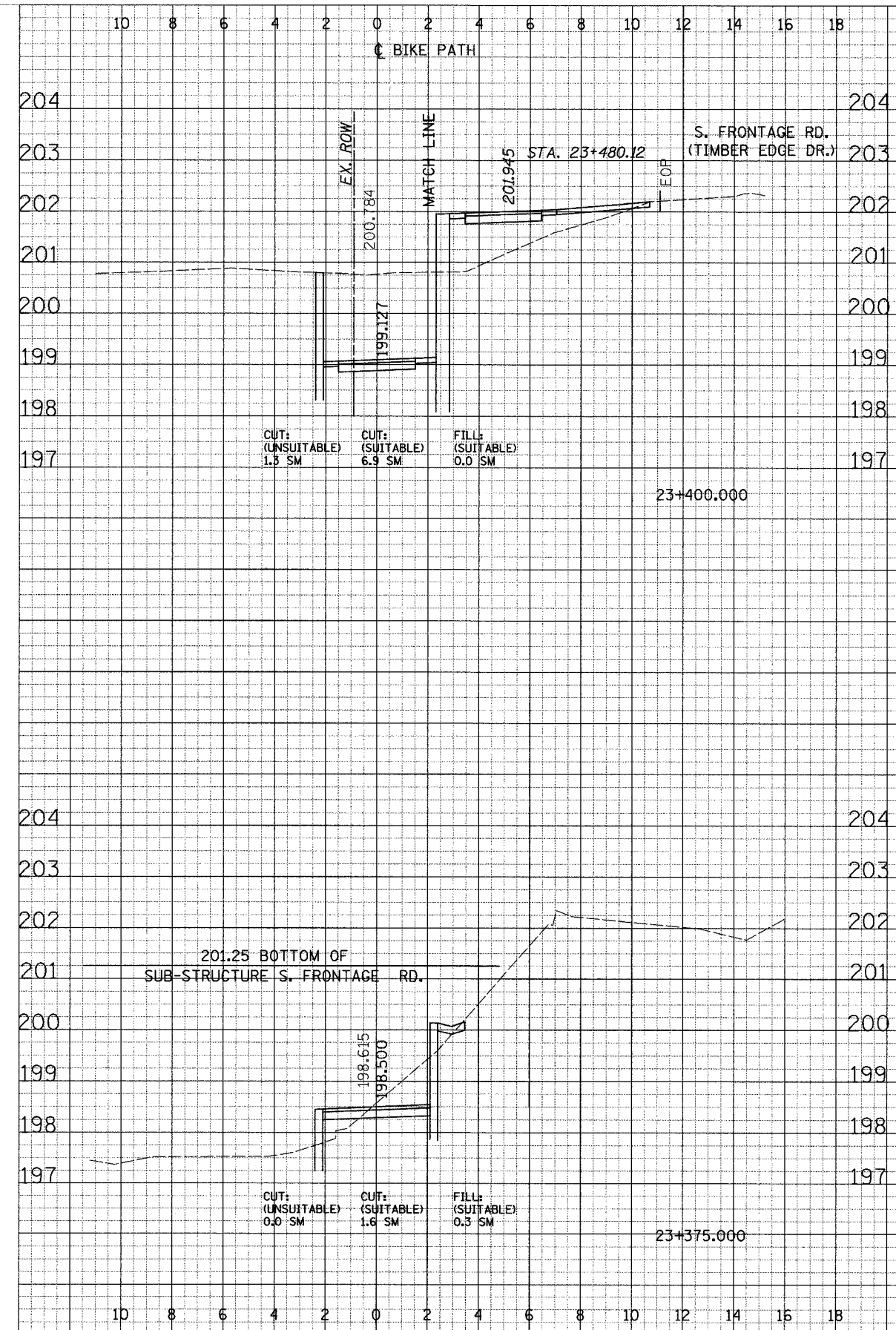

DATE: _____
 BY: _____
 SURVEYED: _____
 PLOTTED: _____
 NOTE BOOK: _____
 AREAS CHECKED: _____
 NO. _____

DATE: _____
 BY: _____
 SURVEYED: _____
 PLOTTED: _____
 NOTE BOOK: _____
 AREAS CHECKED: _____
 NO. _____

DATE: _____ BY: _____
 ORIGINAL SURVEY PLOTTED _____
 NOTE BOOK _____
 AREA CHECKED _____

DATE: _____ BY: _____
 ORIGINAL SURVEY PLOTTED _____
 NOTE BOOK _____
 AREA CHECKED _____

F.A. RTE.	SECTION	COUNTY	TOTAL SHEETS	SHEET NO.
	02-00034-00-BT	DUPAGE	108	99
STA.	TO STA.			
FED. ROAD DIST. NO.	ILLINOIS FED. AID PROJECT	CONTRACT NO. 83714		

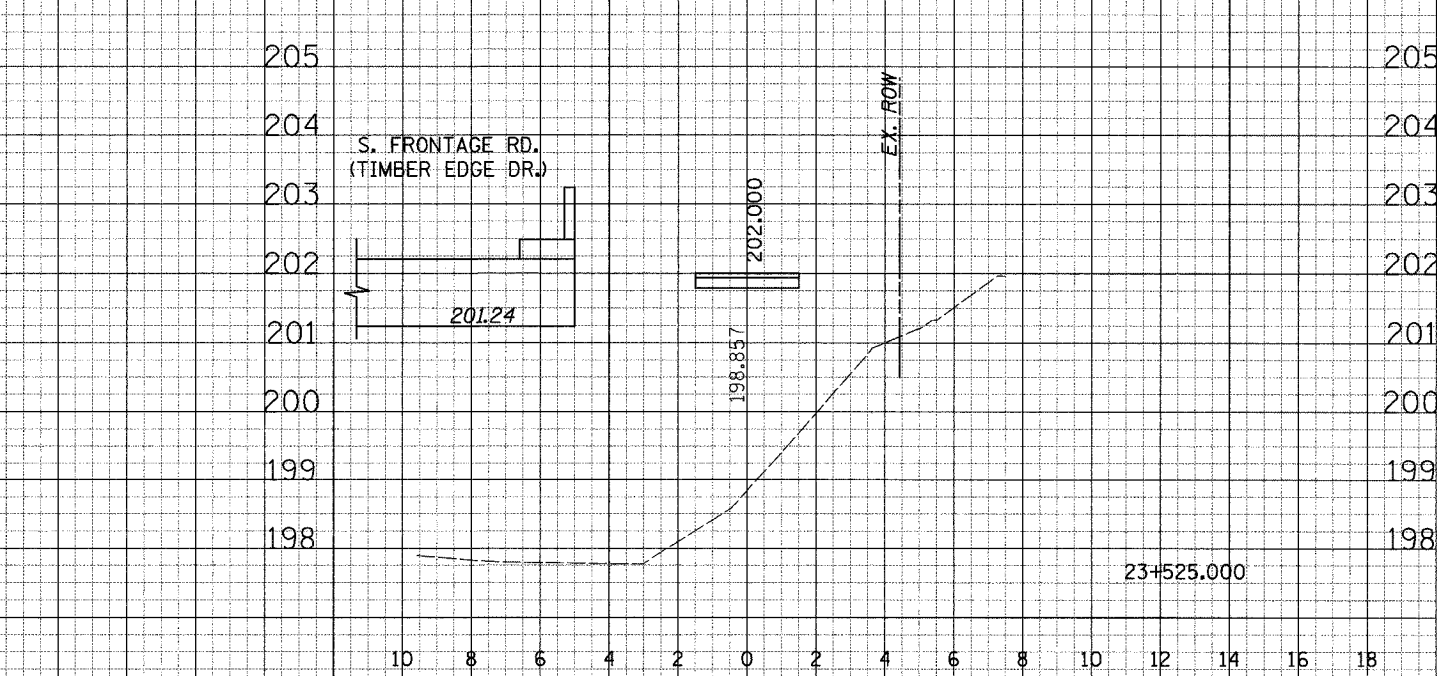
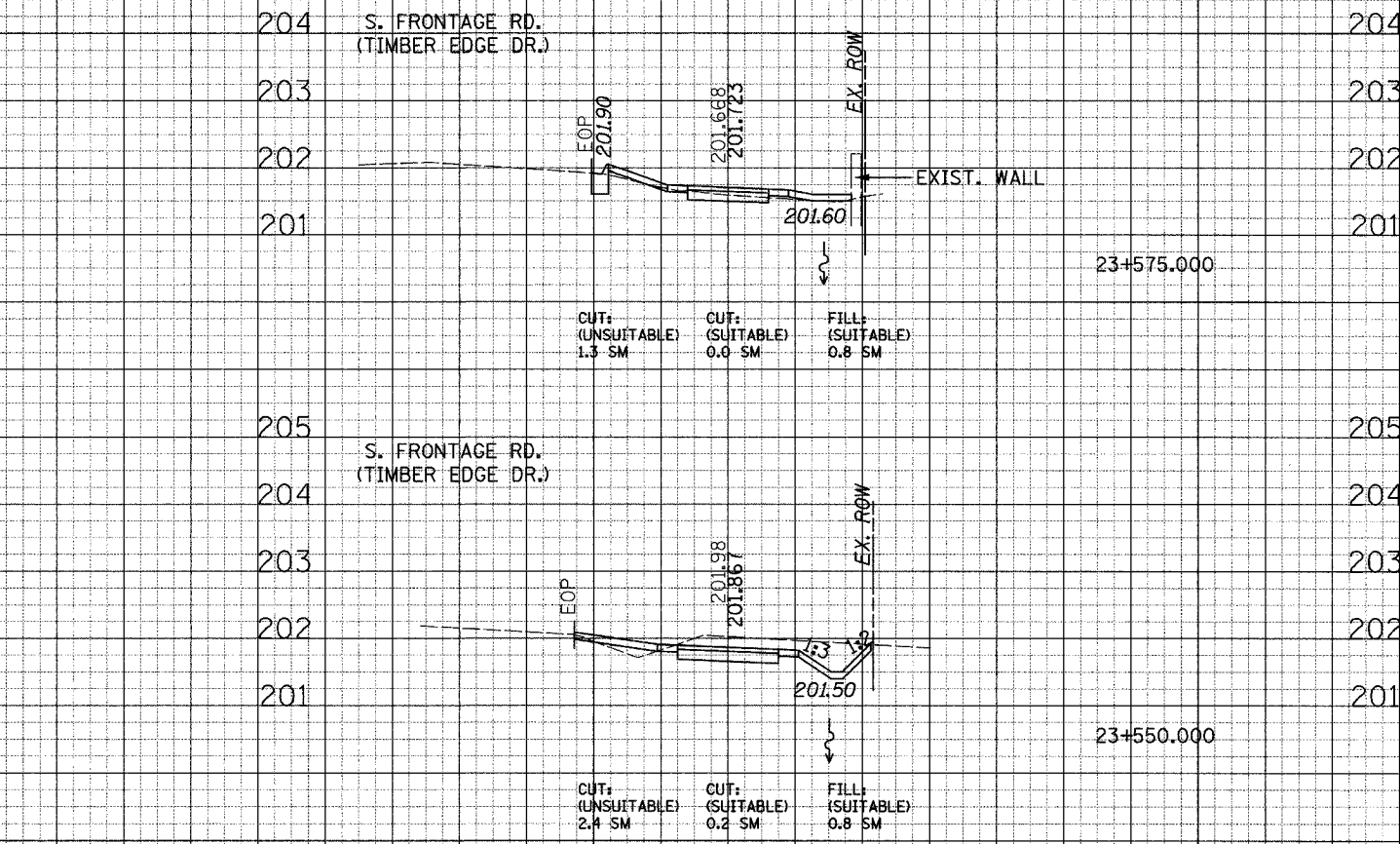
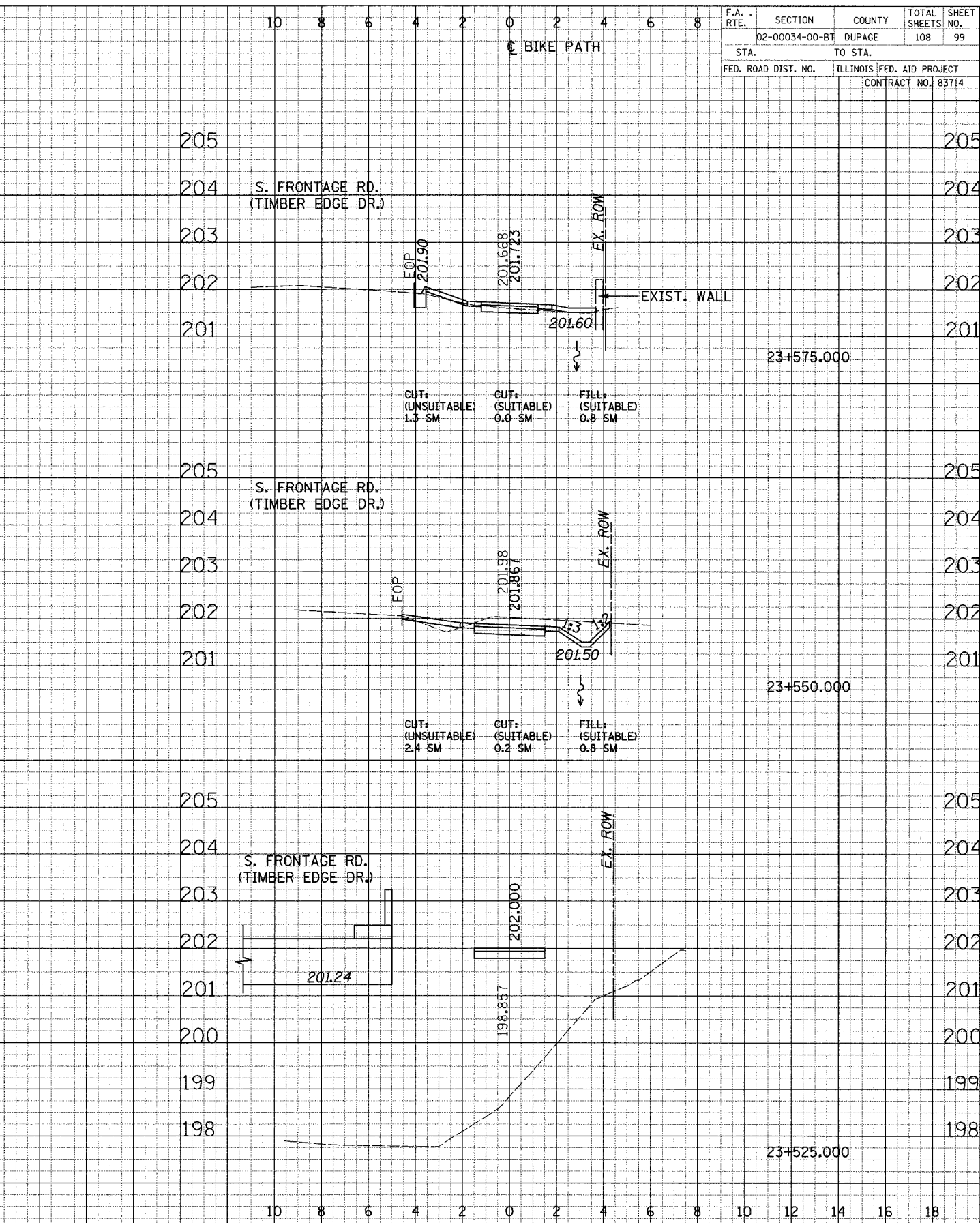
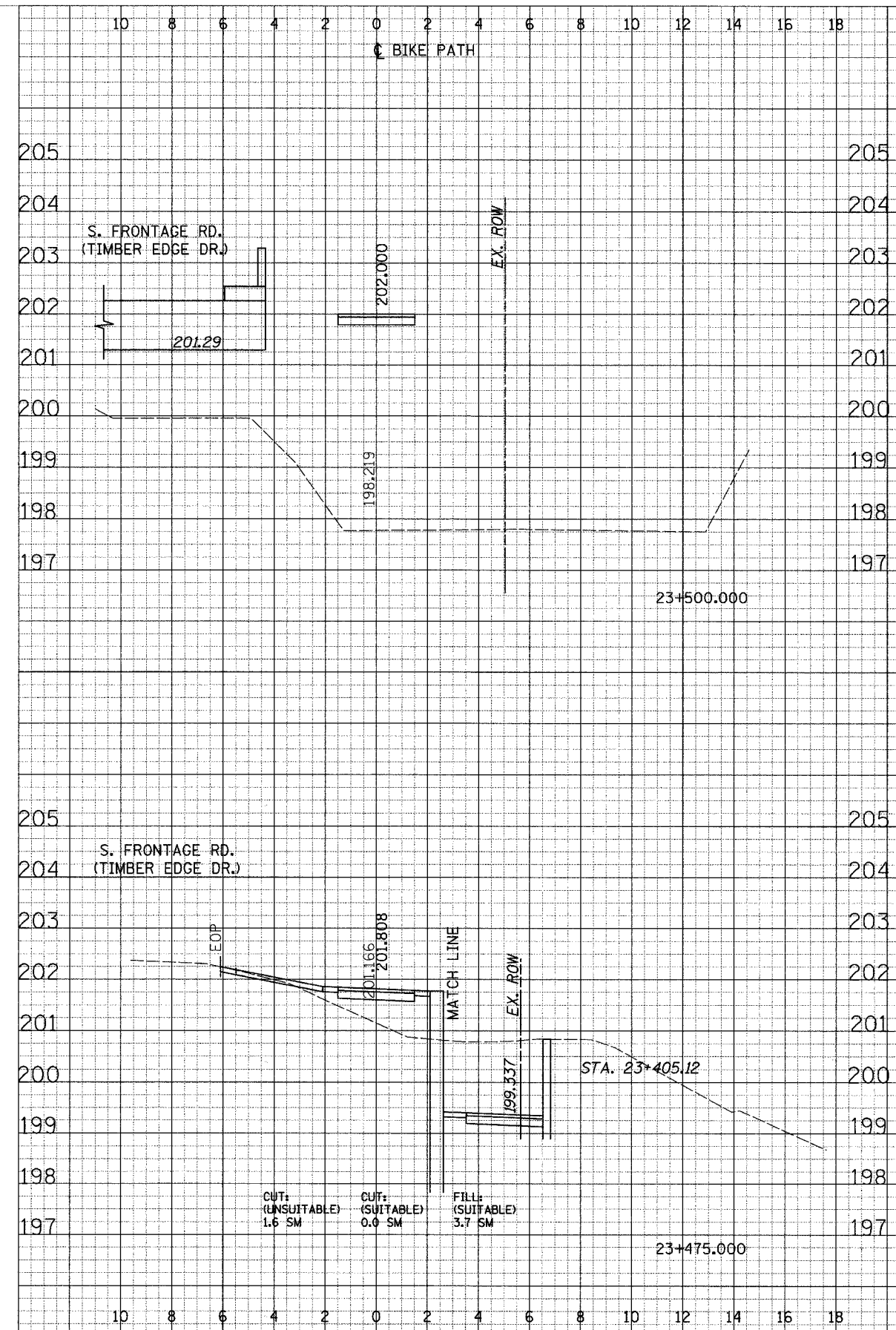

CROSS SECTIONS - OAKBROOK

FINAL SURVEY
 DATE: _____
 BY: _____
 SUPERVISOR: _____
 CHECKED: _____
 DATE: _____
 BY: _____
 SURVEYED: _____
 PLOTTED: _____
 DATE: _____
 BY: _____
 CHECKED: _____
 DATE: _____
 BY: _____

PRELIMINARY SURVEY
 DATE: _____
 BY: _____
 SUPERVISOR: _____
 CHECKED: _____
 DATE: _____
 BY: _____
 SURVEYED: _____
 PLOTTED: _____
 DATE: _____
 BY: _____
 CHECKED: _____
 DATE: _____
 BY: _____

F.A. RTE.	SECTION	COUNTY	TOTAL SHEETS	SHEET NO.
	02-00034-00-BT	DUPAGE	108	100
STA.	TO STA.			
FED. ROAD DIST. NO.	ILLINOIS FED. AID PROJECT			
	CONTRACT NO. 83714			

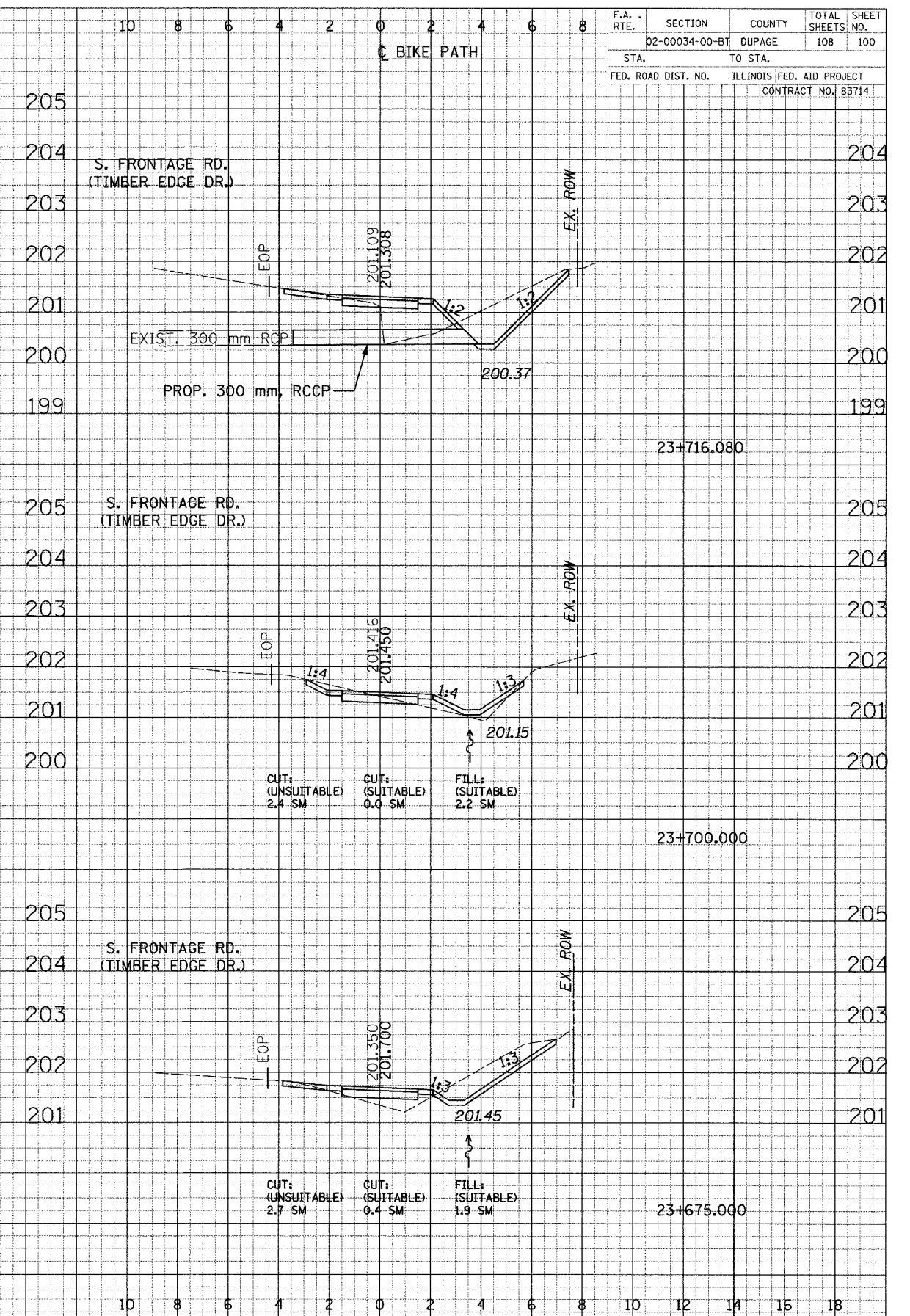
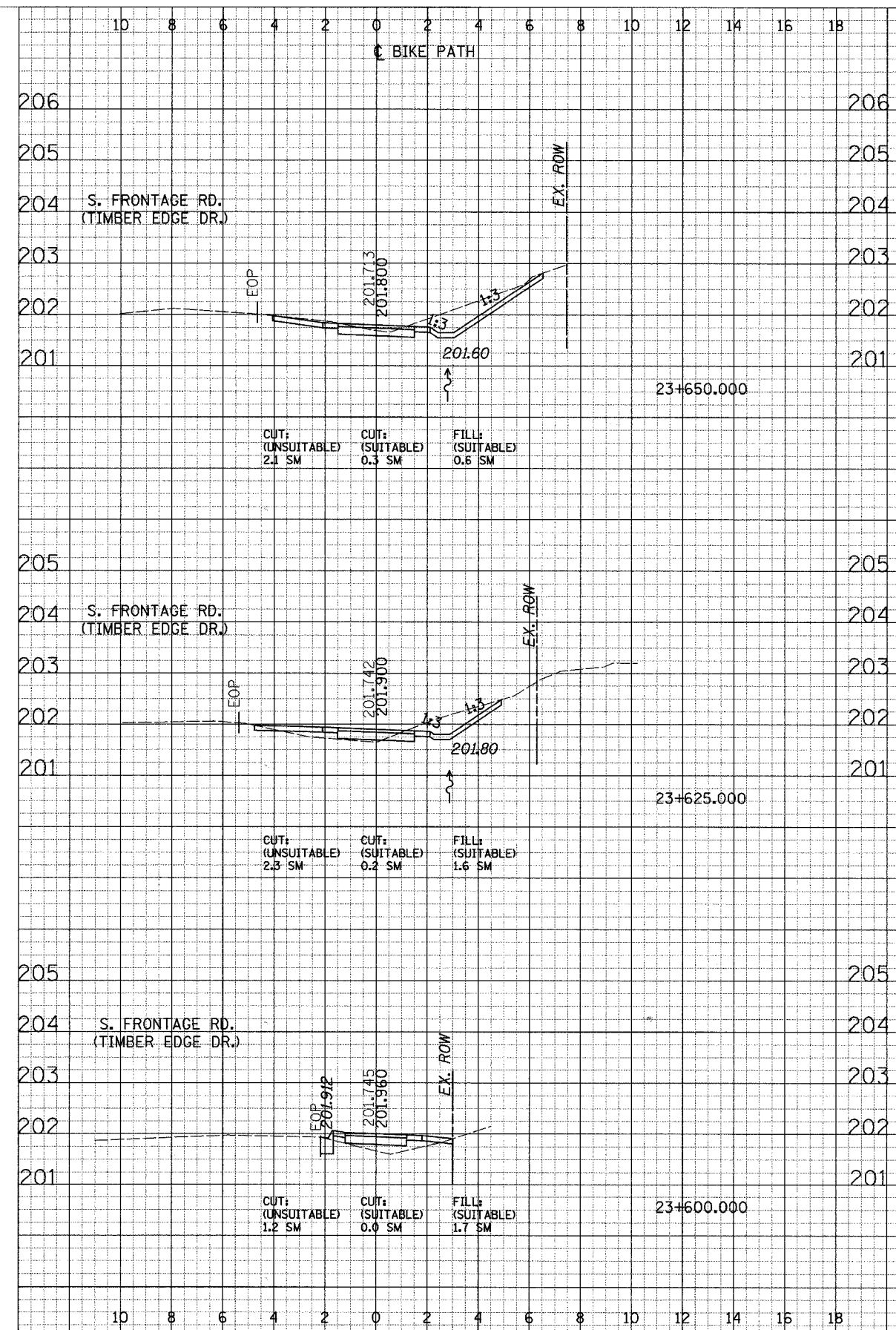

CROSS SECTIONS - OAKBROOK

FINL. SURVEYED BY: _____ DATE: _____
 SURVEY PLOTTED BY: _____
 NOTE BOOK: _____
 AREAS CHECKED: _____

ORIGINAL SURVEY BY: _____ DATE: _____
 SURVEY PLOTTED BY: _____
 NOTE BOOK: _____
 AREAS CHECKED: _____

F.A. RTE.	SECTION	COUNTY	TOTAL SHEETS	SHEET NO.
	02-00034-00-BT	DUPAGE	108	101
STA.	TO STA.			
FED. ROAD DIST. NO.	ILLINOIS FED. AID PROJECT			
	CONTRACT NO. 83714			

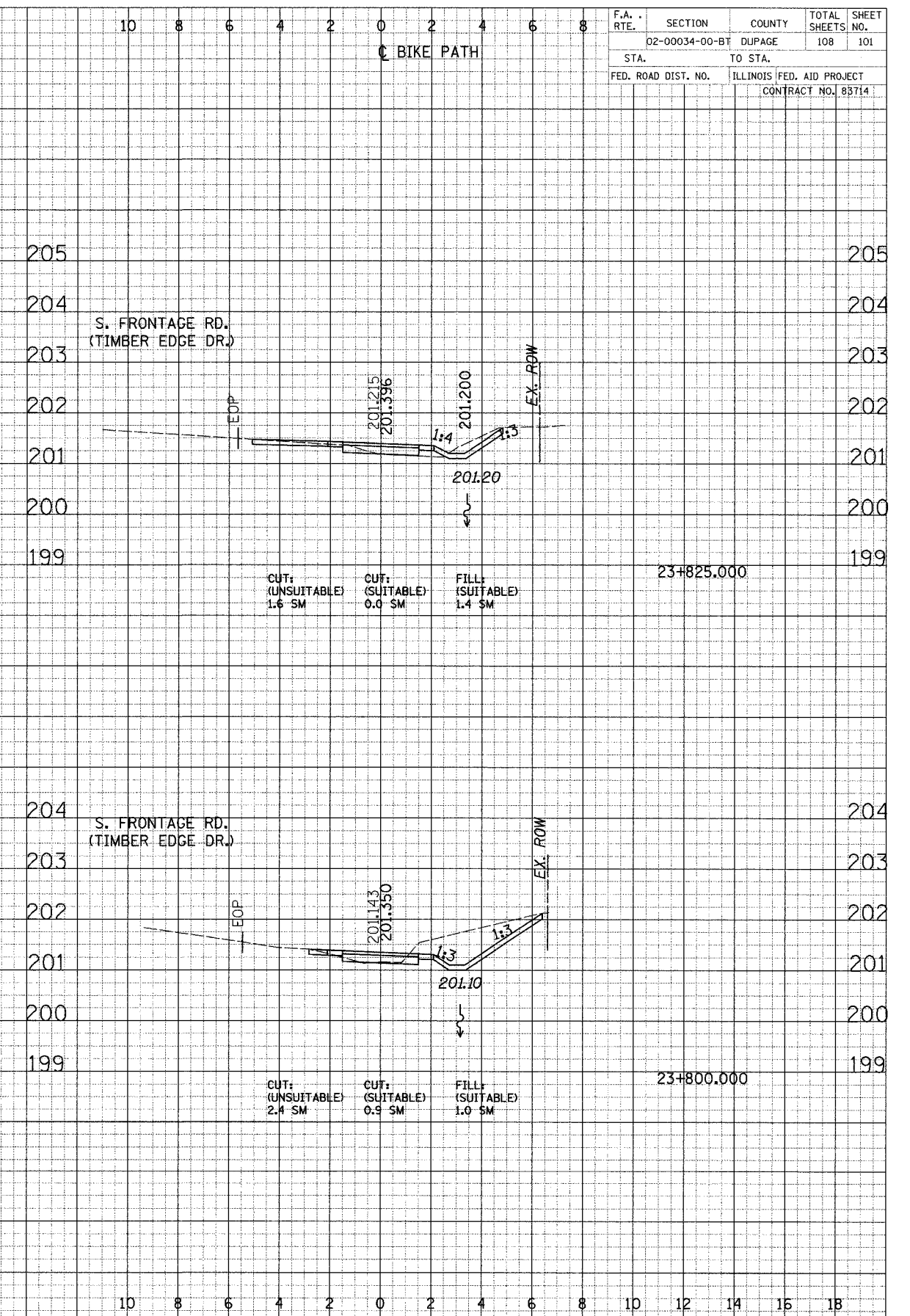
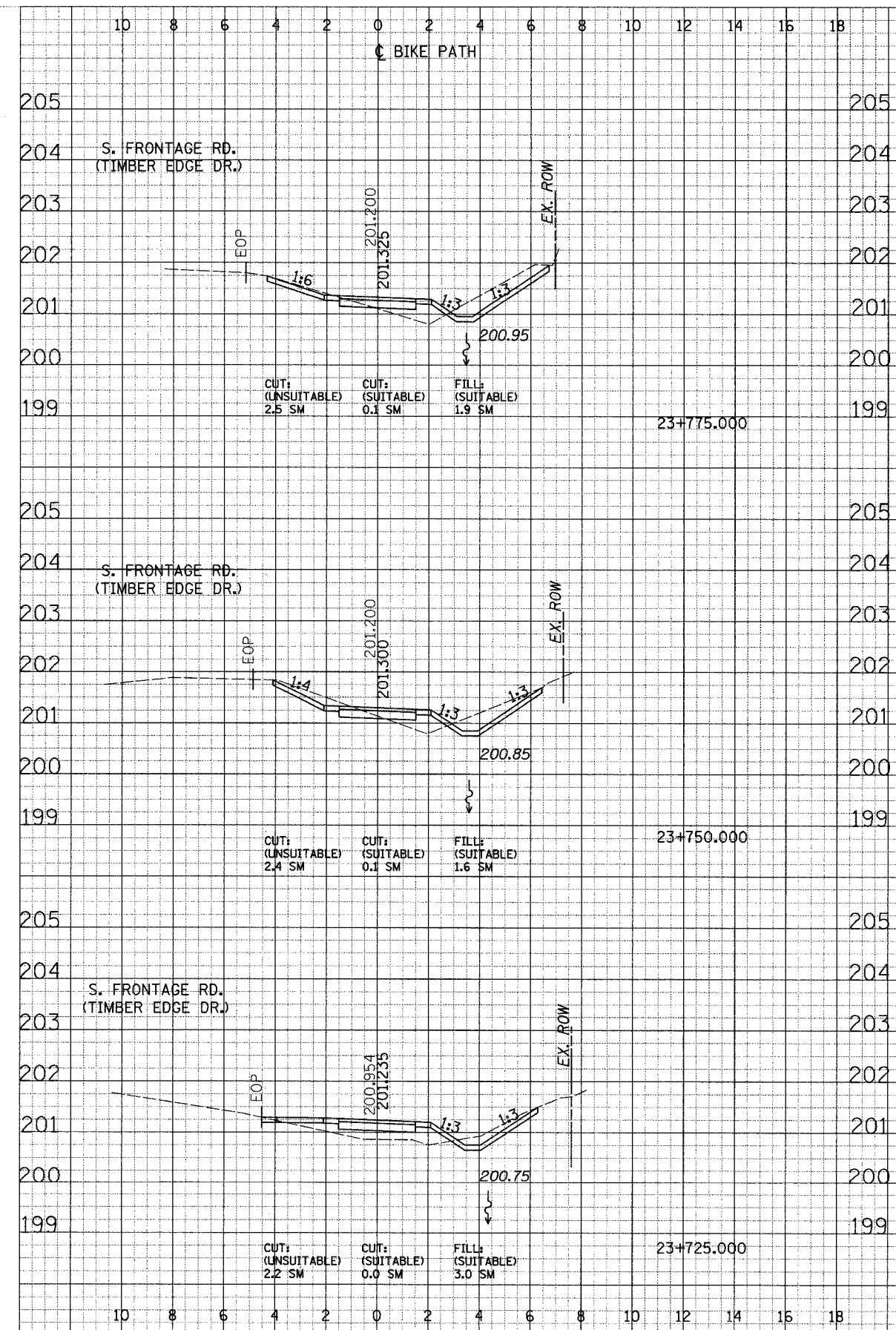

F.A. RTE.	SECTION	COUNTY	TOTAL SHEETS	SHEET NO.
	02-00034-00-BT	DUPAGE	108	102
STA.	TO STA.			
FED. ROAD DIST. NO.	ILLINOIS FED. AID PROJECT CONTRACT NO. 83714			

DATE: _____
 BY: _____
 CHECKED: _____
 SUPERVISOR: _____
 DESIGNED: _____
 DRAWN: _____
 PLOTTED: _____
 DATE: _____
 NO. _____
 AREA CHECKED: _____

DATE: _____
 BY: _____
 CHECKED: _____
 SUPERVISOR: _____
 DESIGNED: _____
 DRAWN: _____
 PLOTTED: _____
 DATE: _____
 NO. _____
 AREA CHECKED: _____

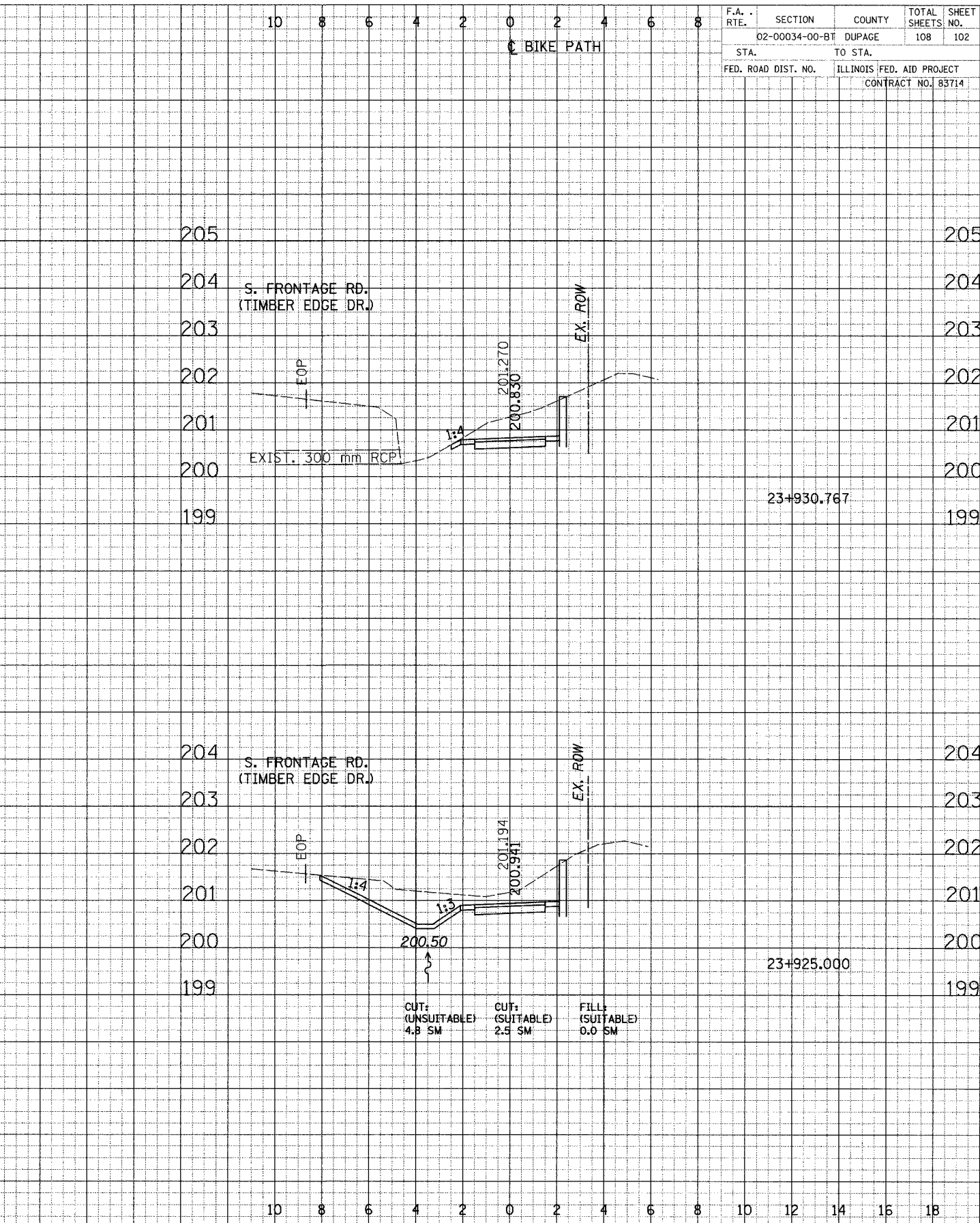
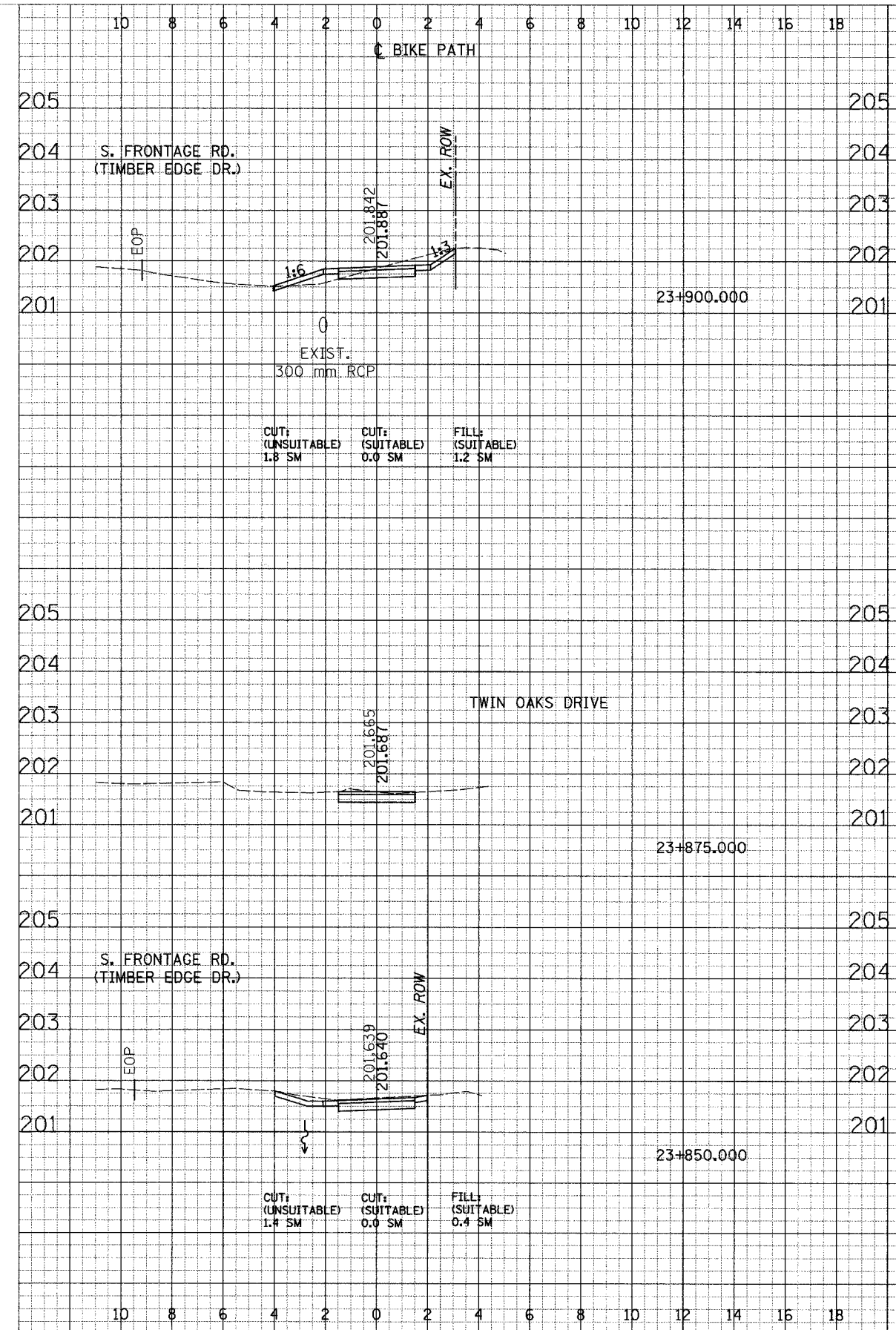

FINL SURVEY
 SURVEY PLOTTED
 NOTE BOOK
 AREAS CHECKED

ORIGINAL SURVEY
 SURVEY PLOTTED
 NOTE BOOK
 AREAS CHECKED



F.A. RTE.	SECTION	COUNTY	TOTAL SHEETS	SHEET NO.
	02-00034-00-BT	DUPAGE	108	103
STA.	TO STA.			
FED. ROAD DIST. NO.	ILLINOIS FED. AID PROJECT CONTRACT NO. 83714			

CROSS SECTIONS - OAKBROOK

FINISH SURVEY PLOTTED DATE: _____
 NOTE BOOK NO. _____
 AREA CHECKED: _____
 BY: _____

ORIGINAL SURVEY PLOTTED DATE: _____
 NOTE BOOK NO. _____
 AREA CHECKED: _____
 BY: _____

F.A. RTE.	SECTION	COUNTY	TOTAL SHEETS	SHEET NO.
	02-00034-00-BT	DUPAGE	108	104
STA.	TO STA.			
FED. ROAD DIST. NO.	ILLINOIS	FED. AID PROJECT		
	CONTRACT NO. 83714			

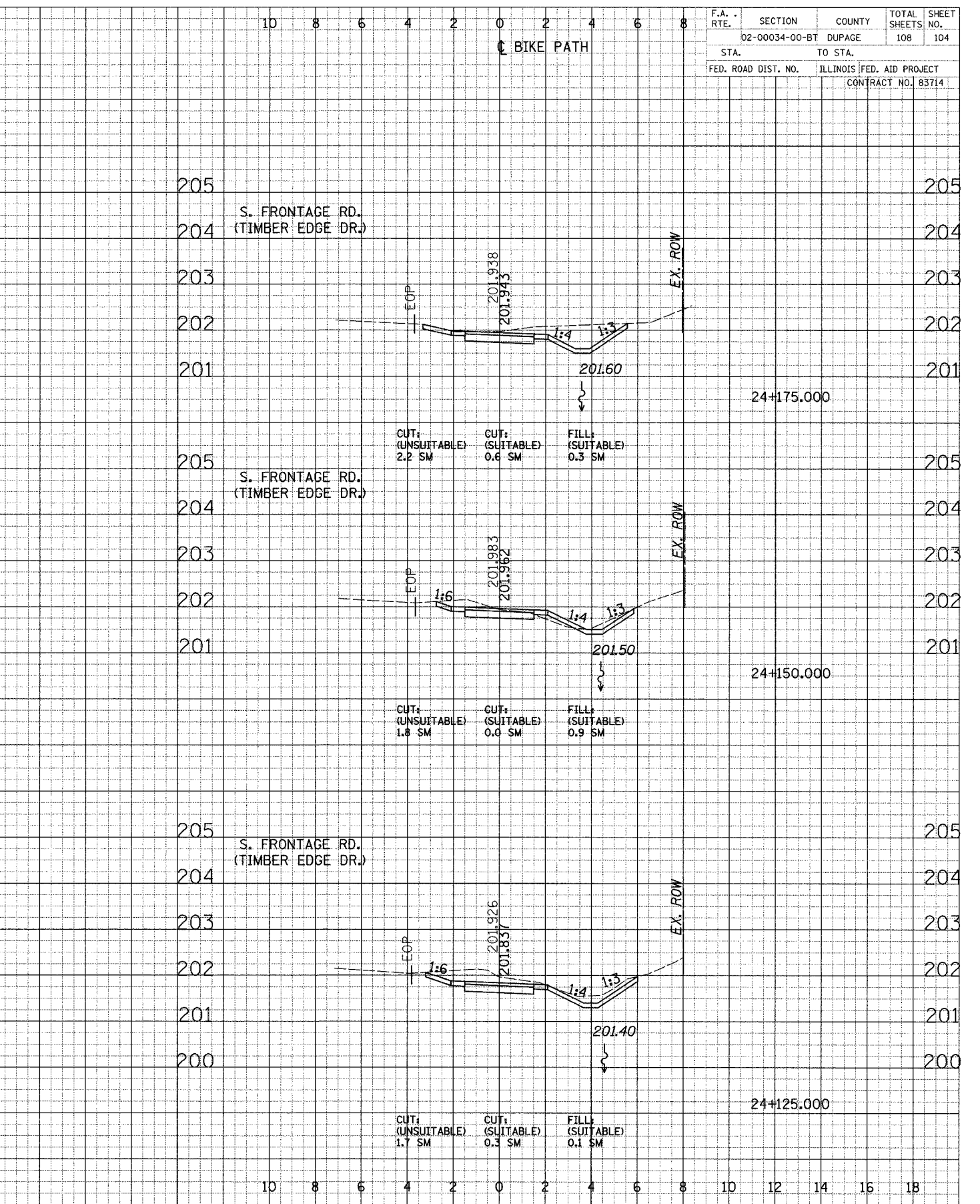
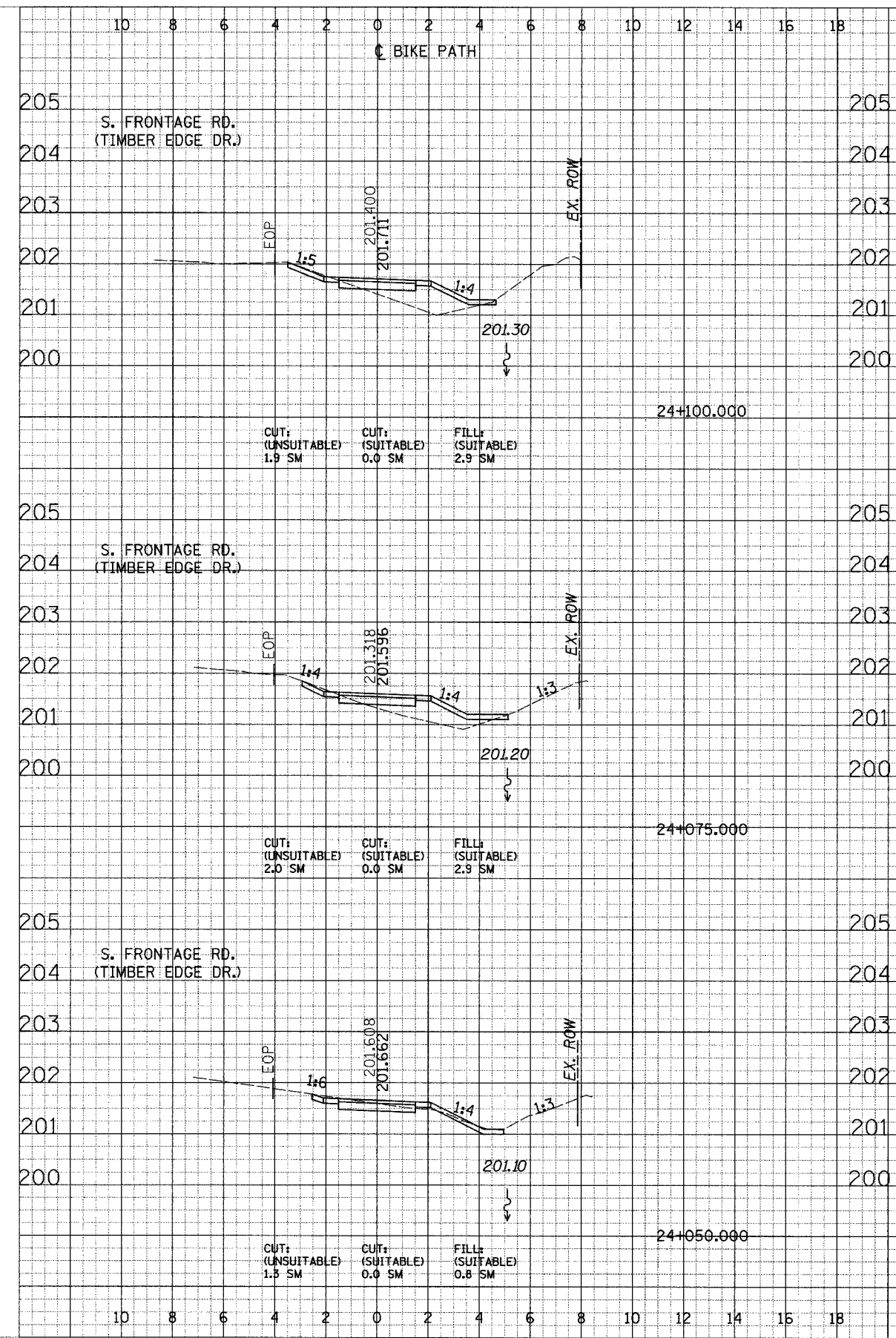

CROSS SECTIONS - OAKBROOK

FINISH SURVEY
 UNREVISED
 PLATTED
 DATE
 NOTE BOOK
 NO.

ORIGINAL SURVEY
 UNREVISED
 PLATTED
 DATE
 NOTE BOOK
 NO.

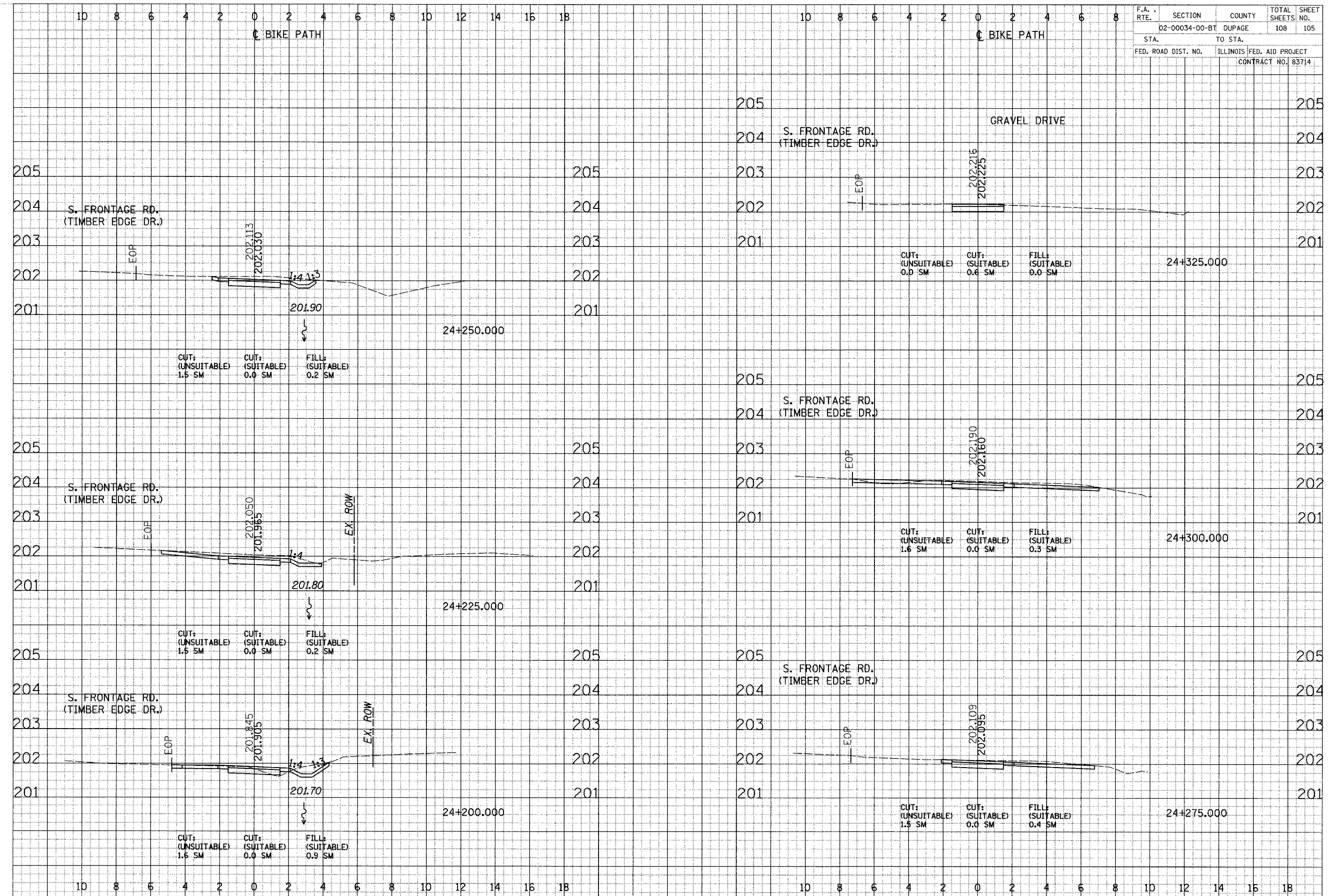

F.A. RTE.	SECTION	COUNTY	TOTAL SHEETS	SHEET NO.
	02-00034-00-BT	DUPAGE	108	105
STA.	TO STA.			
FED. ROAD DIST. NO.	ILLINOIS	FED. AID PROJECT	CONTRACT NO. 63714	

CROSS SECTIONS - OAKBROOK

DATE: _____ BY: _____
 SURVEYED: _____ PLOTTED: _____
 CHECKED: _____ DATE: _____
 NOTE BOOK: _____
 AREA CHECKED: _____

DATE: _____ BY: _____
 SURVEYED: _____ PLOTTED: _____
 CHECKED: _____ DATE: _____
 NOTE BOOK: _____
 AREA CHECKED: _____

F.A. RTE.	SECTION	COUNTY	TOTAL SHEETS NO.	SHEET NO.
	02-00034-00-BT	DUPAGE	108	106
STA.	TO STA.			
FED. ROAD DIST. NO.	ILLINOIS FED. AID PROJECT	CONTRACT NO. 83714		

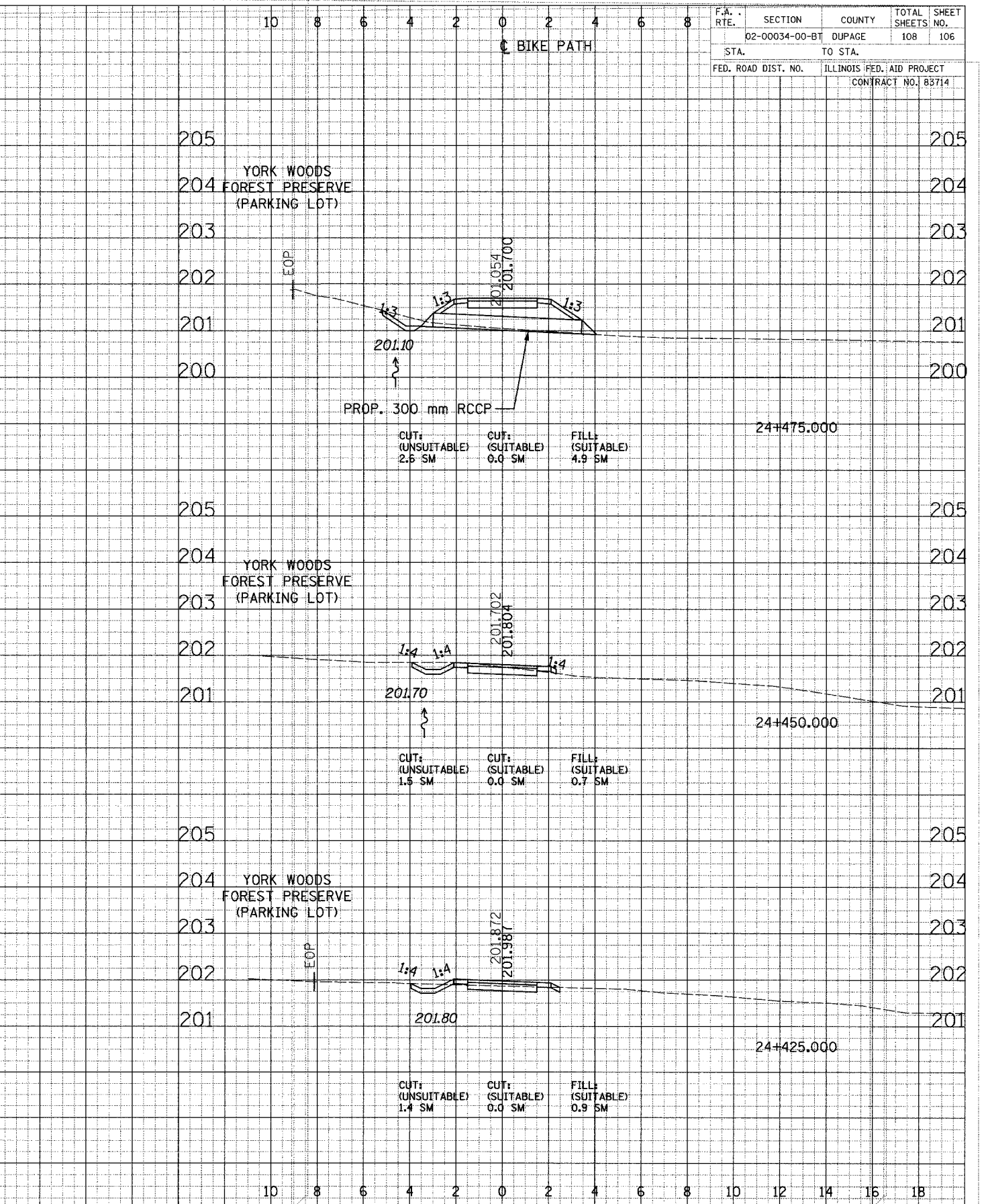
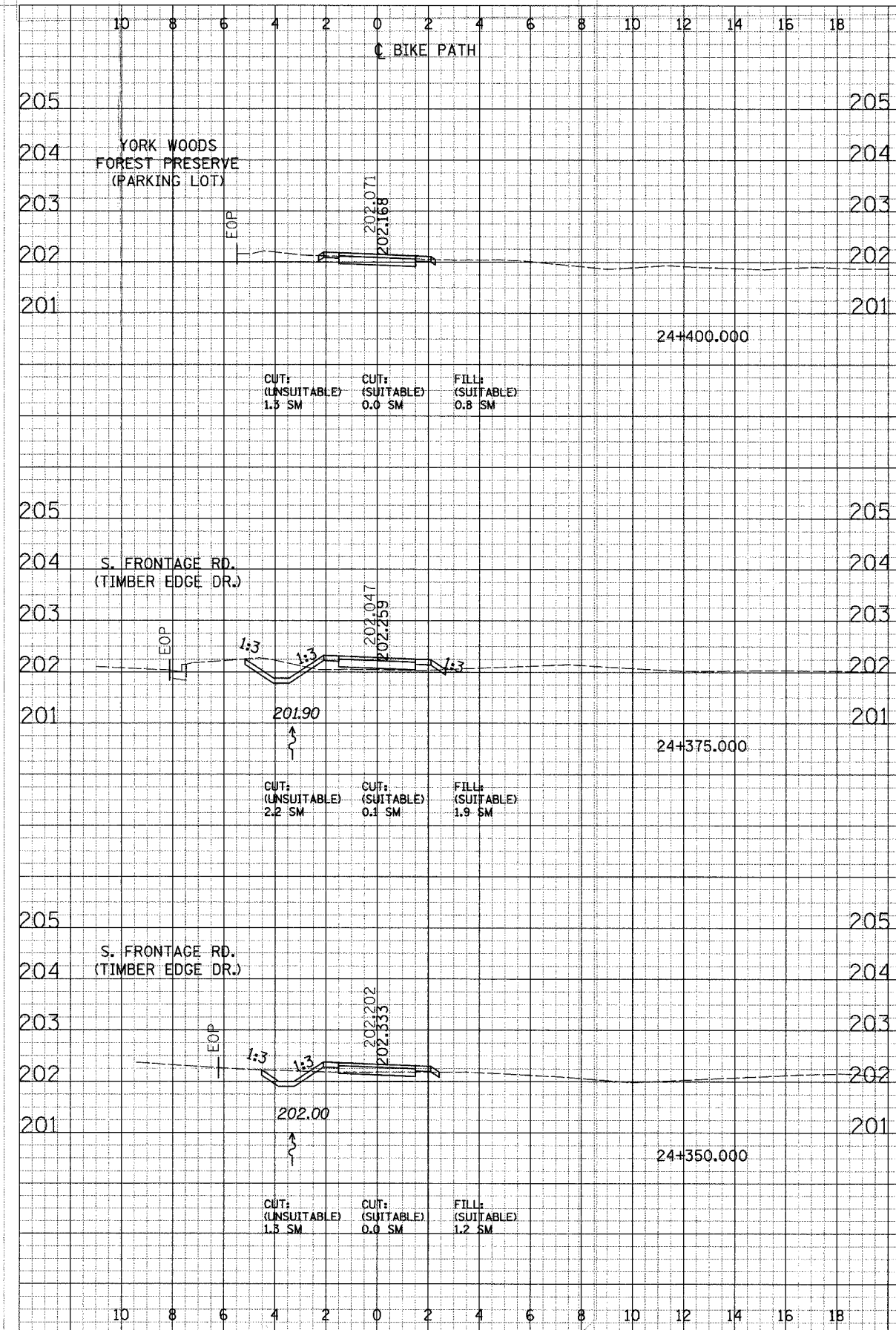

CUT: (UNSUITABLE) 1.3 SM
 CUT: (SUITABLE) 0.0 SM
 FILL: (SUITABLE) 0.8 SM

CUT: (UNSUITABLE) 2.5 SM
 CUT: (SUITABLE) 0.0 SM
 FILL: (SUITABLE) 4.9 SM

CUT: (UNSUITABLE) 2.2 SM
 CUT: (SUITABLE) 0.1 SM
 FILL: (SUITABLE) 1.9 SM

CUT: (UNSUITABLE) 1.5 SM
 CUT: (SUITABLE) 0.0 SM
 FILL: (SUITABLE) 0.7 SM

CUT: (UNSUITABLE) 1.3 SM
 CUT: (SUITABLE) 0.0 SM
 FILL: (SUITABLE) 1.2 SM

CUT: (UNSUITABLE) 1.4 SM
 CUT: (SUITABLE) 0.0 SM
 FILL: (SUITABLE) 0.9 SM

FINISH	DATE
CORRECTED	BY
REVISIONS	
NO.	

ORIGINAL	DATE
CORRECTED	BY
REVISIONS	
NO.	

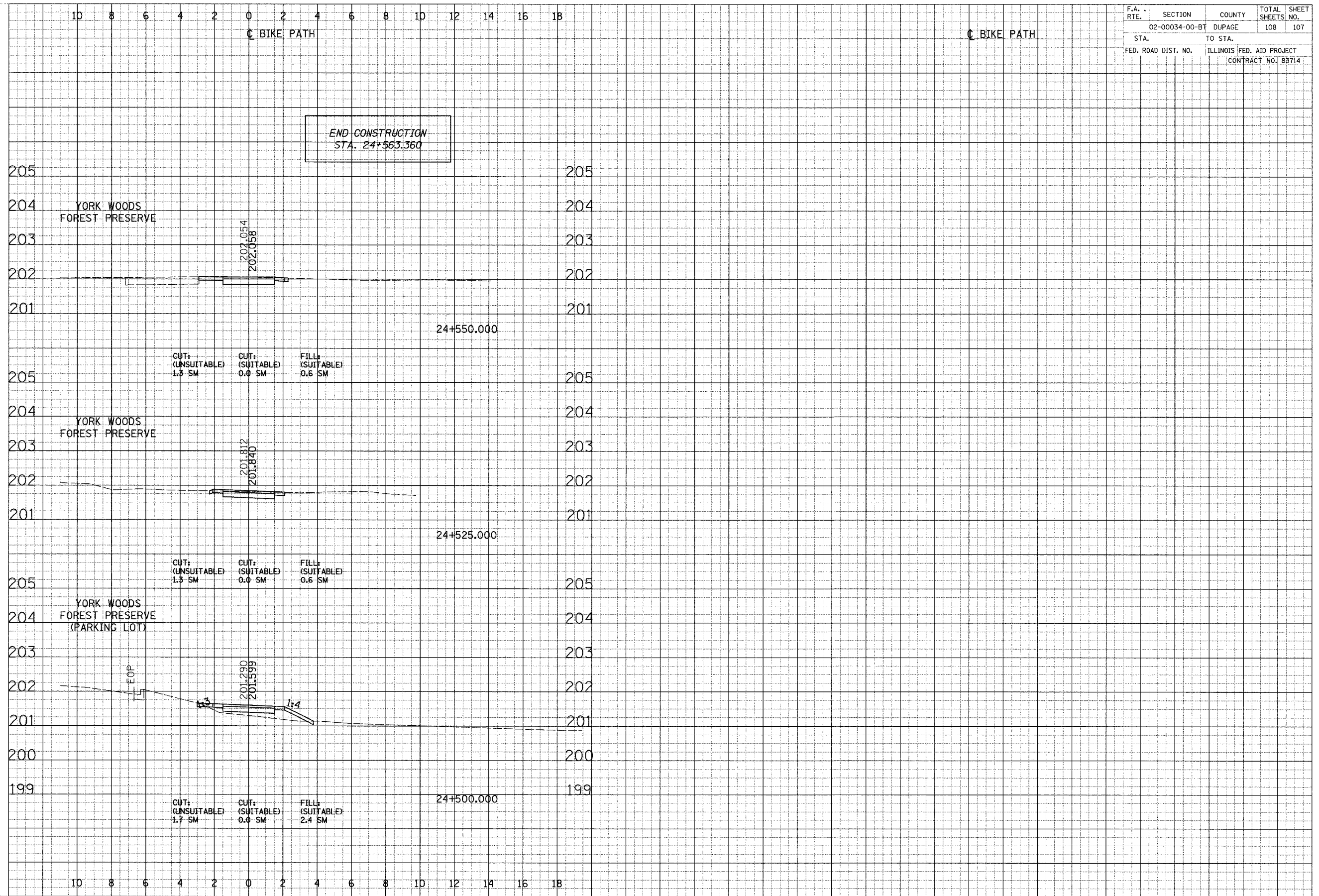

F.A. RTE.	SECTION	COUNTY	TOTAL SHEETS	SHEET NO.
	02-00034-00-BT	DUPAGE	108	107
STA.	TO STA.			
FED. ROAD DIST. NO.	ILLINOIS	FED. AID PROJECT	CONTRACT NO. 83714	

F.A. RTE.	SECTION	COUNTY	TOTAL SHEETS	SHEET NO.
02-00034-00-BT	DUPAGE		108	108
STA.	TO STA.			
FED. ROAD DIST. NO.	ILLINOIS	FED. AID PROJECT		
	CONTRACT NO. 83714			

FINAL SURVEY	DATE
REVISION	
DATE	

ORIGINAL SURVEY	DATE
REVISION	
DATE	

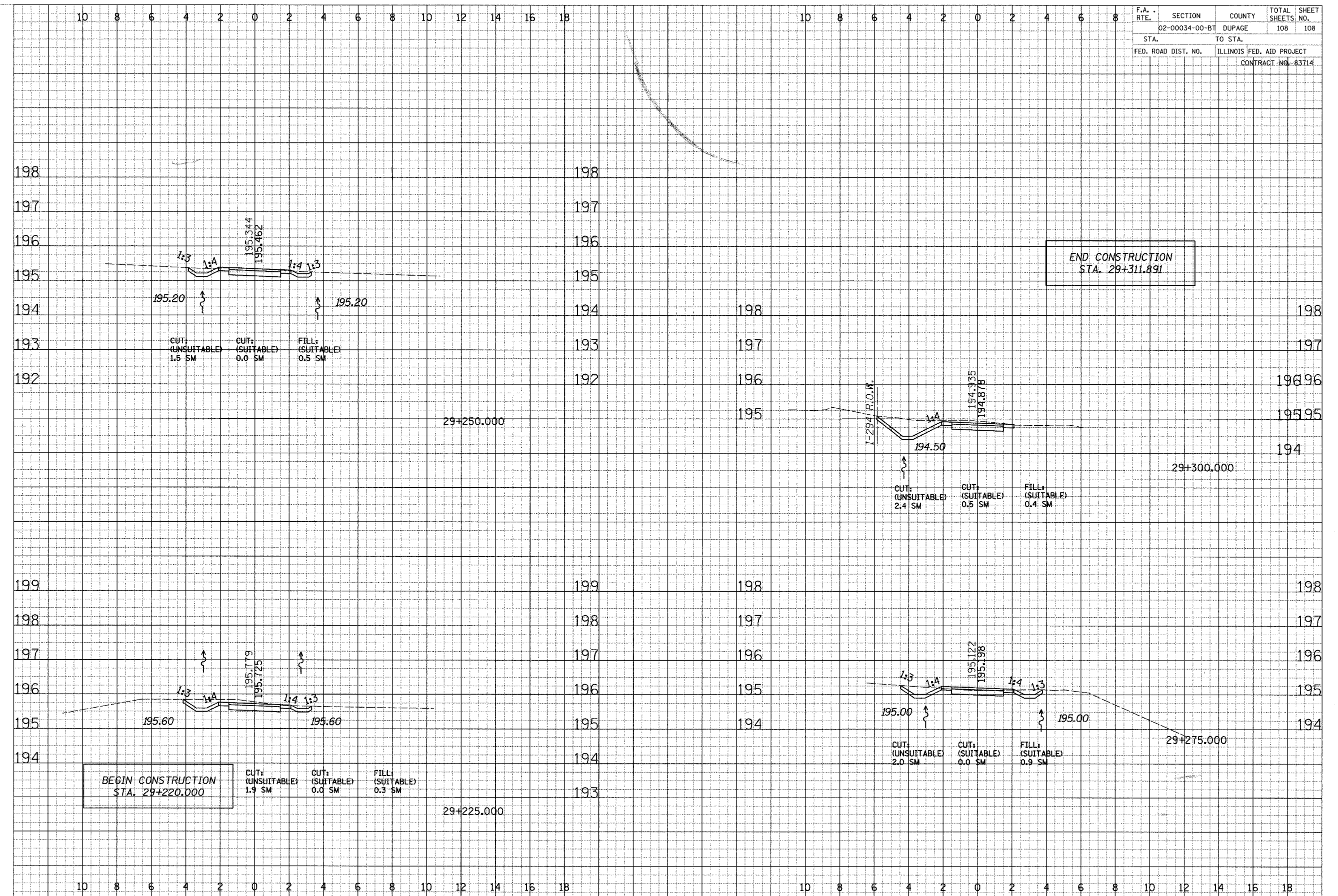

CROSS SECTIONS - CANTERBERRY LN