

|                       |                |                     |              |           |
|-----------------------|----------------|---------------------|--------------|-----------|
| F.A.P. RTE.           | SECTION        | COUNTY              | TOTAL SHEETS | SHEET NO. |
|                       | 06-00096-00-SW | DU PAGE             | 16           | 13        |
| FEDERAL RD. DIST. NO. | ILLINOIS       | FEDERAL AID PROJECT |              |           |
| CONTRACT: 83851       |                |                     |              |           |

**CONSTRUCTION NOTES**

- A. 5' NORMAL WIDTH OR AS INDICATED ON PLANS
- B. AGGREGATE BASE COURSE, TYPE B, 2"
- C. P.C.C. SIDEWALK
- D. SLOPE 1/4" PER FOOT TO STREET SIDE, OR AS NOTED ON PLAN
- E. JOINTS, SEE NOTES 3 AND 4
- F. SLOPE 2% TO 8% TOWARDS STREET
- G. CURB AND GUTTER
- H. CONCRETE THICKNESS, SEE NOTE 1

**GENERAL NOTES**

- 1. STANDARD THICKNESS OF CONCRETE SHALL BE A MINIMUM OF 5".
- 2. WHERE WOODEN FORMS ARE USED, 2x4'S ARE NOT ALLOWED. ONLY 2x6'S SHALL BE USED.
- 3. PREFORMED 3/4" EXPANSION JOINTS SHALL BE CONSTRUCTED AT MAX. SPACING OF 40'.
- 4. FORMED OR SAW-CUT CONTRACTION JOINTS SHALL BE SPACED GENERALLY 5' APART, BUT NO LESS THAN 4' AND NO MORE THAN 6'.
- 5. 1/2" EXPANSION JOINTS SHALL BE INSTALLED WHERE SIDEWALK ABUTS BUILDINGS, TRAFFIC SIGNAL FOUNDATIONS, SERVICE POLES, AND OTHER IMMOVABLE STRUCTURES.
- 6. CONCRETE TO BE MINIMUM 6-BAG MIX.

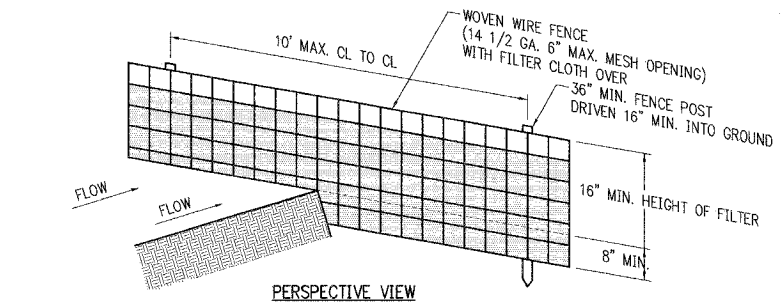

PERSPECTIVE VIEW

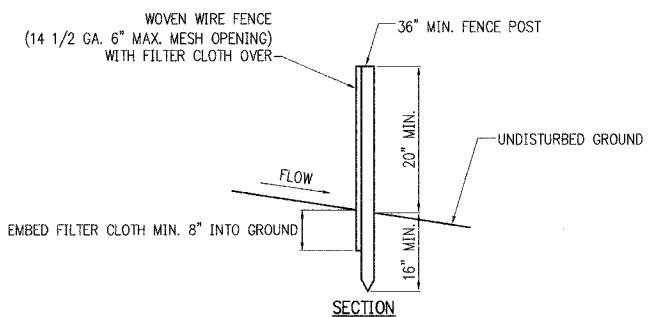

SECTION

**SILT FENCE**

N.T.S.

**CONSTRUCTION NOTES FOR FABRICATED SILT FENCE**

- 1. WOVEN WIRE FENCE TO BE FASTENED SECURELY TO FENCE POSTS WITH WIRE TIES OR STAPLES.
- 2. FILTER CLOTH TO BE FASTENED SECURELY TO WOVEN WIRE FENCE WITH TIES SPACED EVERY 24" AT TOP AND MID SECTION.
- 3. WHEN TWO SECTIONS OF FILTER CLOTH ADJOIN EACH OTHER THEY SHALL BE OVER LAPPED BY 6" AND FOLDED.
- 4. MAINTENANCE SHALL BE PERFORMED AS NEEDED AND MATERIAL REMOVED WHEN "BULGES" DEVELOP IN THE SILT FENCE.

POSTS: STEEL EITHER 'T' OR 'U' TYPE OR 2" HARDWOOD  
 FENCE: WOVEN WIRE 14 1/2 GA. 6" MAX. MESH OPENING  
 FILTER CLOTH: FILTER X, MIRAFI 100X OR STABLINKA T140N  
 PREFABRICATED UNIT: GOEFAB, ENVIROFENCE

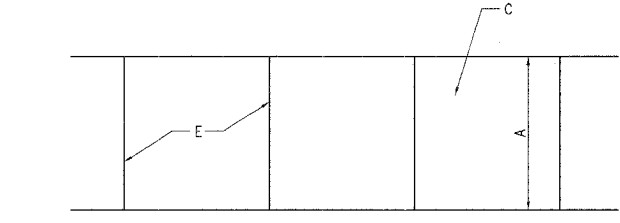

PLAN

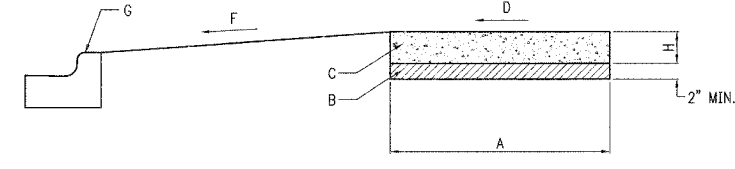

PROFILE

**SIDEWALK DETAIL**

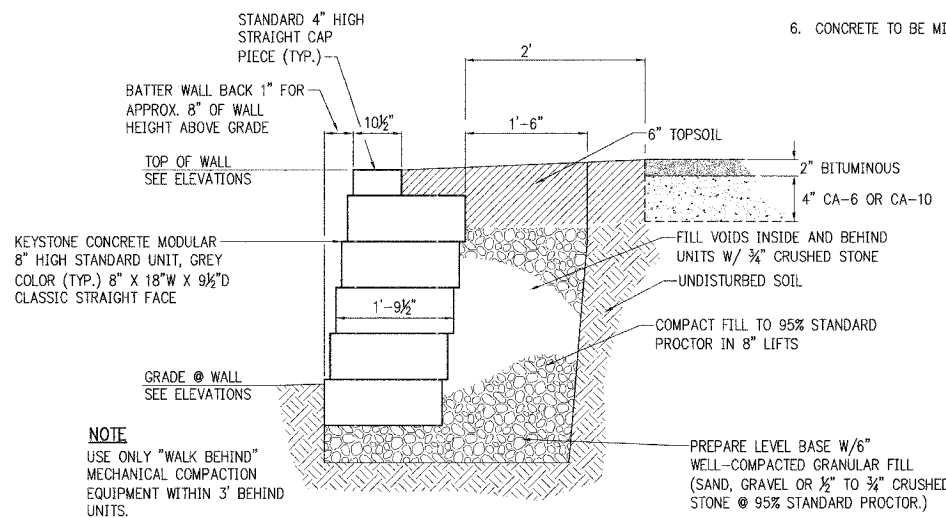

**SEGMENTAL CONCRETE BLOCK WALL TYPICAL SECTION**

NOT TO SCALE

**NOTE**  
 USE ONLY "WALK BEHIND" MECHANICAL COMPACTION EQUIPMENT WITHIN 3' BEHIND UNITS.

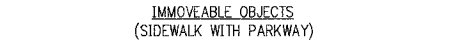
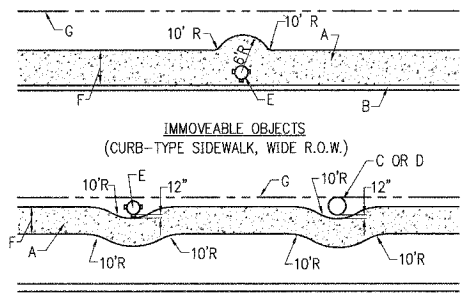
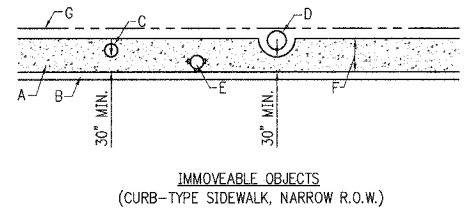

**SIDEWALK OBSTRUCTIONS**

N.T.S.

**CONSTRUCTION NOTES:**

- A. STAMPED CONCRETE PAVEMENT OR CONCRETE BRICK PAVERS.
- B. FOR CONCRETE-ROUND FRAME SHALL BE EQUIVALENT TO TYLER 6895 VALVE BOX. FOR BRICK PAVERS-SQUARE FRAME SHALL BE EQUIVALENT TO NEENAH B-1978-1 INSPECTION FRAME.
- C. COMPACTED AGGREGATE BASE, MIN. 2".
- D. SERVICE BOX LID WITH BRASS PENTAGON HEAD PLUG, TOP TO BE MARKED "WATER".
- E. SERVICE BOX EXTENSION.
- F. SERVICE BOX SET 4"-6" BELOW FINISHED GRADE.
- G. SUBGRADE.

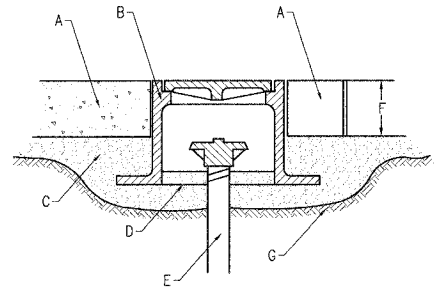

**SERVICE BOX INSTALLATION IN PAVEMENT AREAS**

N.T.S.

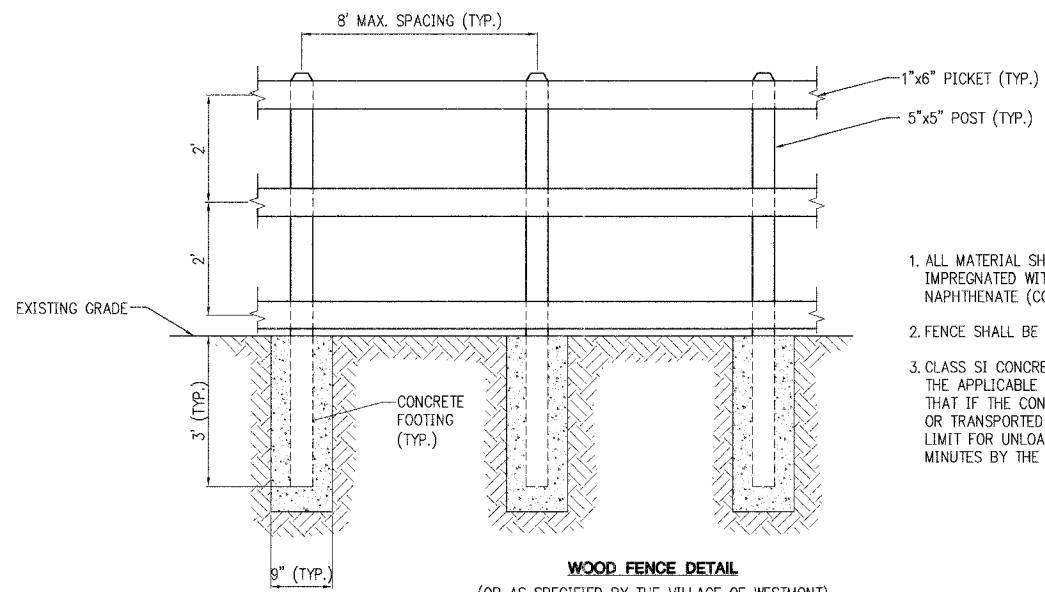

**WOOD FENCE DETAIL**

(OR AS SPECIFIED BY THE VILLAGE OF WESTMONT) NOT TO SCALE

- 1. ALL MATERIAL SHALL BE SOUTHERN YELLOW PINE IMPREGNATED WITH THE PRESERVATIVE, COPPER NAPHTHENATE (COPPERWOOD OR APPROVED EQUAL).
- 2. FENCE SHALL BE ASSEMBLED BY FACE NAILING.
- 3. CLASS SI CONCRETE SHALL BE USED CONFORMING TO THE APPLICABLE PORTIONS OF SECTION 1020, EXCEPT THAT IF THE CONCRETE IS MIXED IN TRANSIT MIXERS OR TRANSPORTED IN AGITATOR TRUCKS, THE TIME LIMIT FOR UNLOADING IT MAY BE EXTENDED TO 120 MINUTES BY THE ENGINEER.



|          |          |          |           |
|----------|----------|----------|-----------|
| date     | 11-11-05 | detailed | L.SAUCEDO |
| designed | M. KUNTZ | checked  |           |



|  |              |
|--|--------------|
| VILLAGE OF WESTMONT                                    |              |
| 2006 CMAQ SIDEWALK MISCELLANEOUS DETAILS (1 OF 2)      |              |
| project  | contract     |
| 39606  |              |
| drawing  | rev.         |
| sheet 13   | of 16 sheets |
| file: I:\WESTMONT\39606-2006 SW DESIGN\CAD\BIDDDETAILS |              |

Scale For Microfilming

Inches

COPYRIGHT © 2005 BURNS AND MCDONNELL ENGINEERING COMPANY, INC.