

BILL OF MATERIAL

Item	Unit	Quantity
Furnishing & Erecting Structural Steel	L. Sum	0.34
Stud Shear Connectors	Each	4,680

Notes:
Work this Sheet with Sheet SE-18.
For bearing details see Sheet SE-20.
All splice material shall be M270 Grade 50.

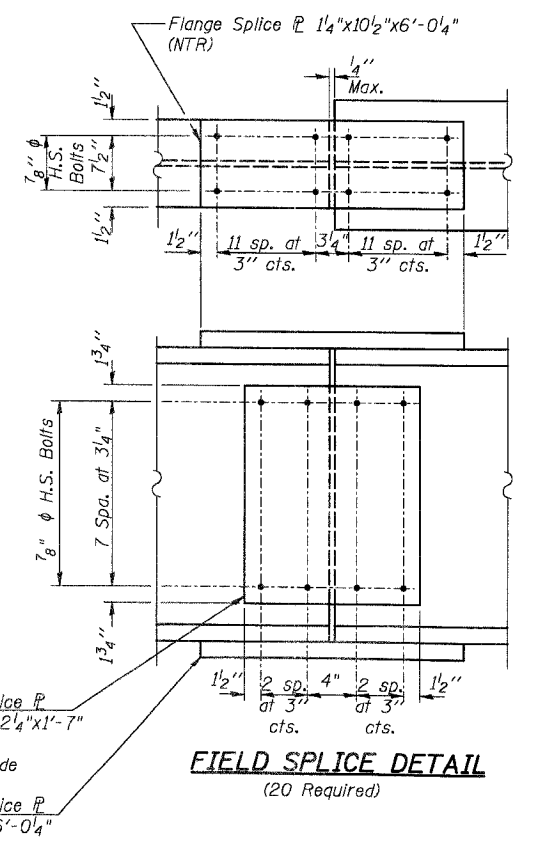
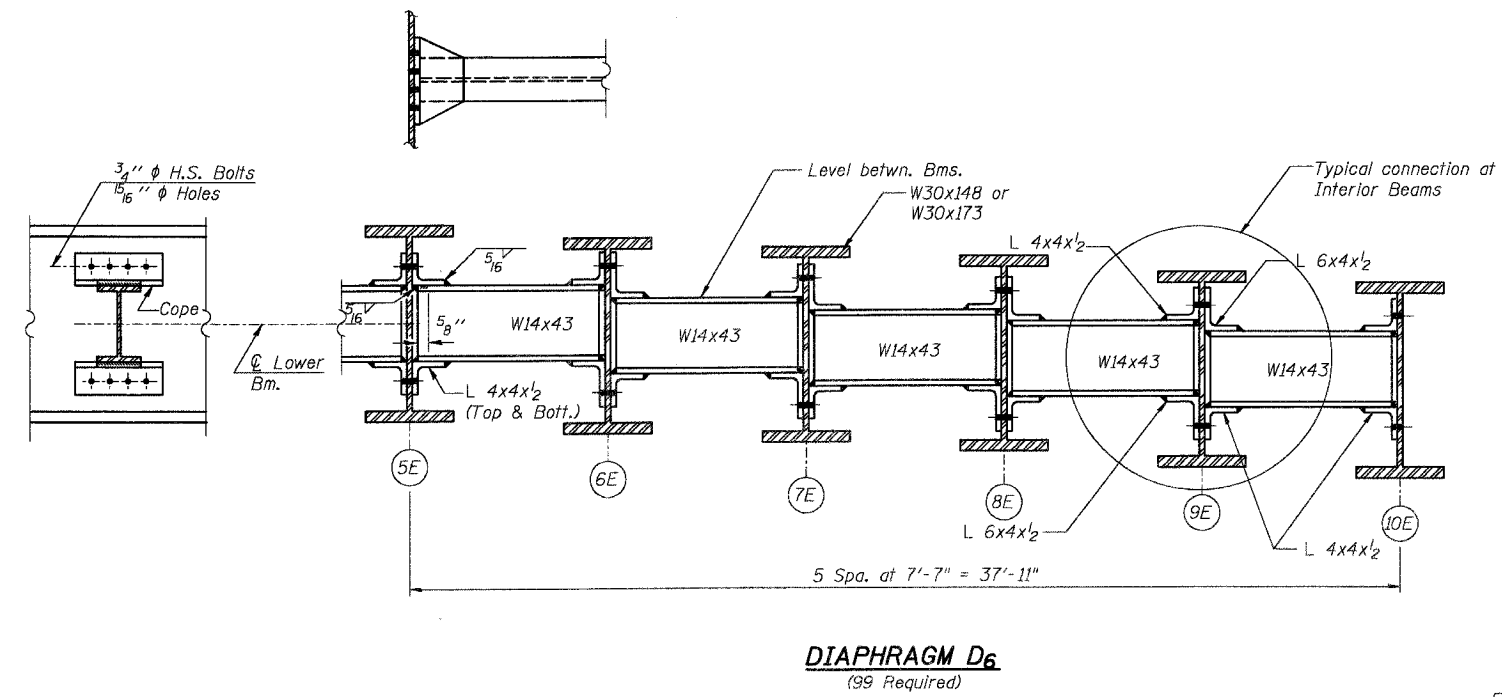
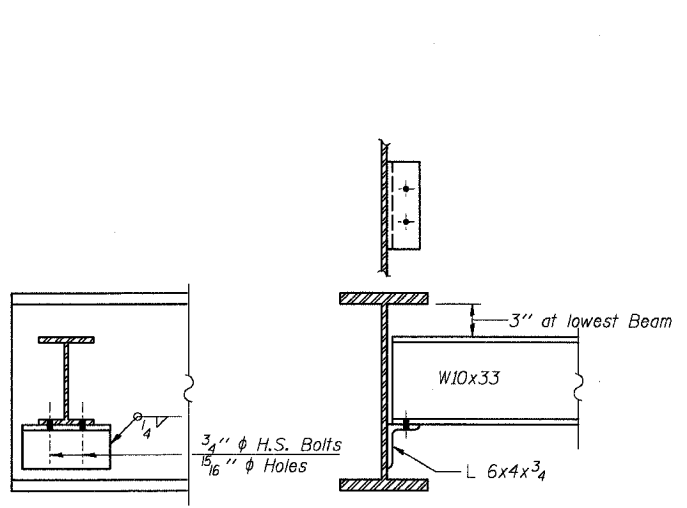
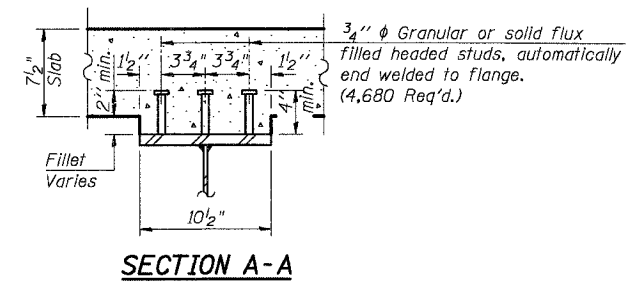

DESIGNED	AEU
CHECKED	RGD
DRAWN	WJH
CHECKED	NRF

Note:
Two hardened washers shall be required over all oversize holes for diaphragms.

SMITH ENGINEERING CONSULTANTS, INC.
CIVIL, STRUCTURAL, ELECTRICAL, MECHANICAL, AND SURVEYING ENGINEERS
1000 WEST WASHINGTON STREET, SUITE 200
AURORA, ILLINOIS 60007
TEL: 630-584-1100 FAX: 630-584-1101

REVISIONS	
NAME	DATE

CITY OF AURORA

**STEEL FRAMING DETAILS
OVER THE FOX RIVER**
SECTION NO. 03-00247-00-BR
KANE COUNTY
STRUCTURE NO. 045-6008

DATE 7-28-2006