

90933

F.A. RTE.	SECTION	COUNTY	TOTAL SHEETS	SHEET NO.
			31	10E
FED. ROAD DIST. NO.		ILLINOIS FED. AID PROJECT		

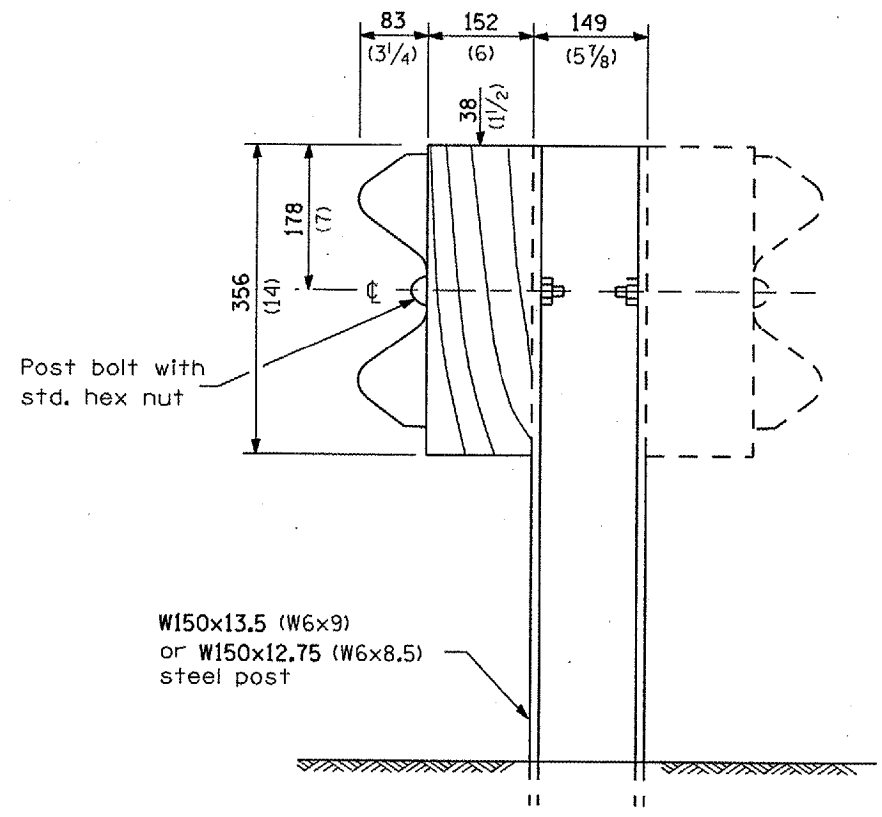

STEEL POST CONSTRUCTION

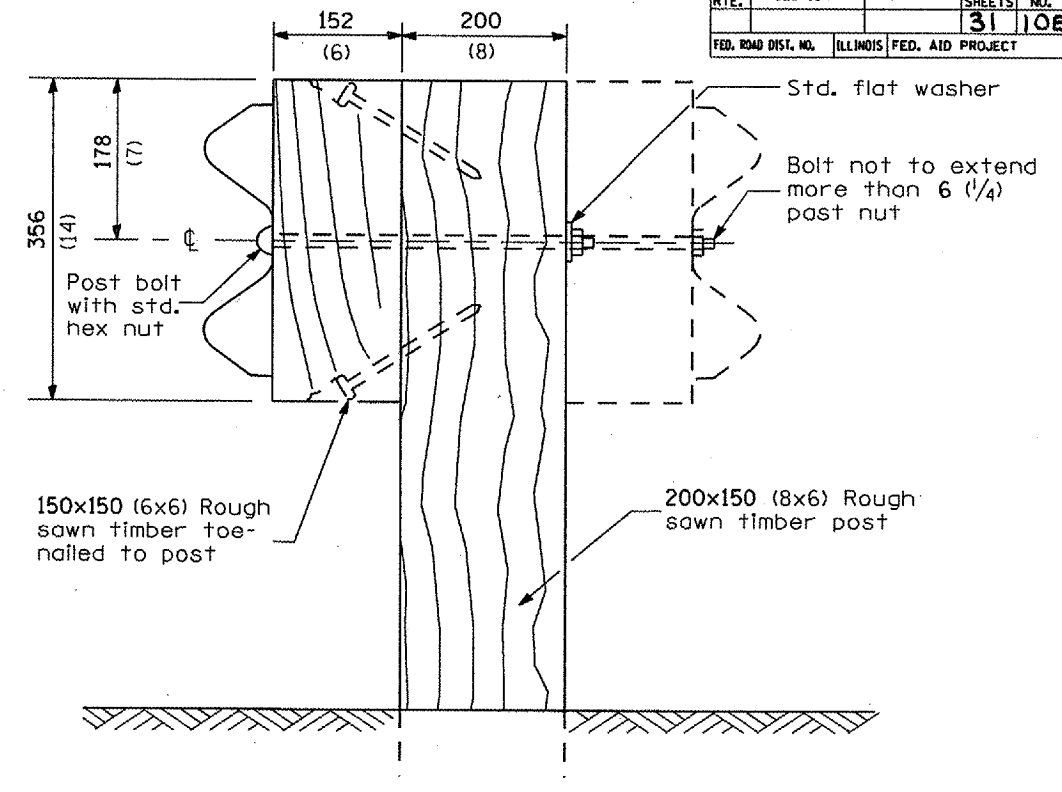

WOOD POST CONSTRUCTION

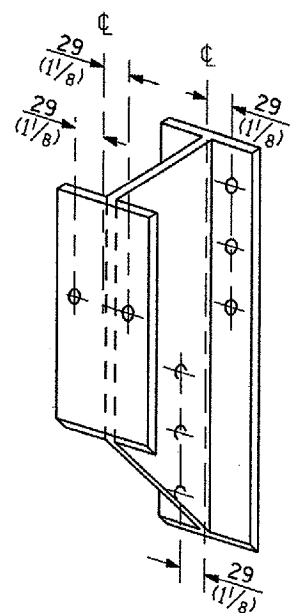

STEEL BLOCK-OUT DETAIL

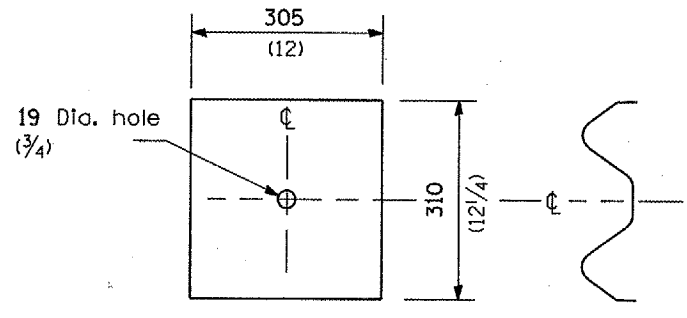

NOTE

Plate A shall be placed between rail element and block-out at non-splice mounting points only when steel block-outs are used.

PLATE A

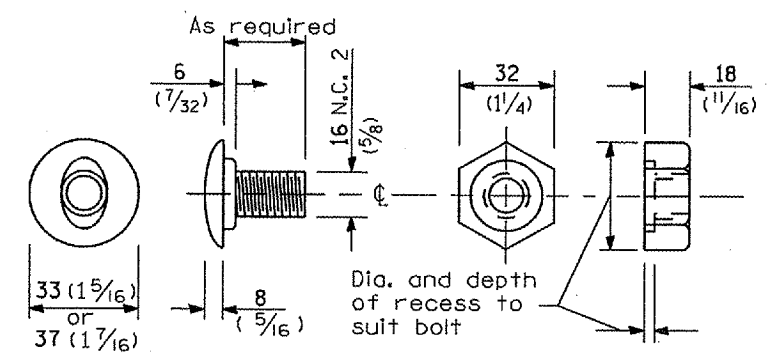

POST OR SPLICE BOLT & NUT

**REMOVE AND REERECT
STEEL PLATE BEAM GUARDRAIL**

(Sheet 2 of 4)

DETAIL

▲ ADDED 1/4/07