

ROUTE NO.	SECTION	COUNTY	TOTAL SHEETS	SHEET NO.
C.H. 20	05-00195-00-BR	MACON	18	15
FED. ROAD DIST. NO.		ILLINOIS PROJECT BRS-549(101)		

CONTRACT NO. 95492

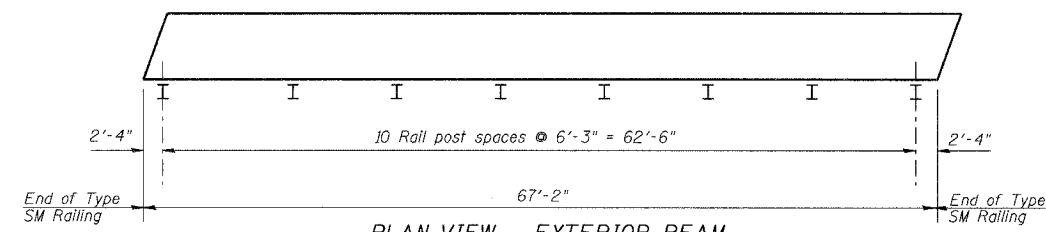

PLAN VIEW - EXTERIOR BEAM
(Showing Rail Post Spacing)

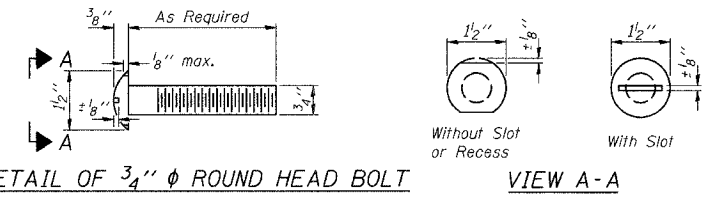

DETAIL OF 3/4" ϕ ROUND HEAD BOLT

VIEW A-A

RAIL SPLICE CONNECTION AT EXPANSION JT.

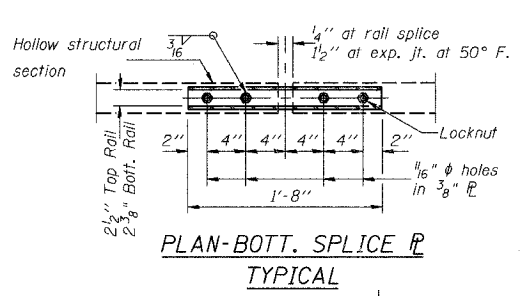

PLAN-BOTT. SPLICE TYPICAL

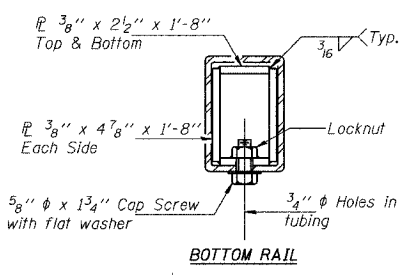

BOTTOM RAIL

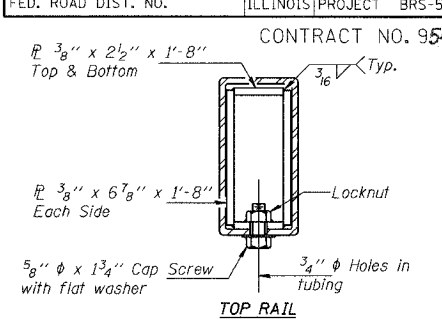

TOP RAIL

SECTIONS AT RAIL SPLICE

NOTES

Hollow structural sections shall conform to the requirements of ASTM designation A 500 Grade B Structural Steel Tubing and shall meet the longitudinal CVN requirements of 15 ft-lbs at 0° F. All other steel shapes and plates shall conform to the requirements of AASHTO M 270 Grade 36 except posts and angles shall conform to AASHTO M 270, Grade 50. Bolts, cap screws, and nuts shall conform to the requirements of ASTM designation A 307 except for high strength bolts, nuts and washers noted which shall conform to AASHTO M 164. All bolts, nuts, cap screws, washers and lock washers shall be galvanized according to AASHTO M 232. All posts, railing, rail splices, anchor devices and angles shall be galvanized after shop fabrication according to AASHTO M 111 and ASTM A 385. Galvanized rail shall not be painted. Railing shall be according to Section 509 of the Standard Specifications, except as noted, and will be paid for at the contract unit price per foot for Steel Bridge Rail, Type SM. All field drilled holes shall be coated with an approved zinc rich paint before erection. For multi-span bridges, sufficient 1/4" x 6" x 1'-2" galvanized steel shims shall be provided to align rail between adjacent spans. Cost included with Steel Bridge Rail, Type SM. The 1/2" x 7" x 6" plates that come in contact with concrete shall receive two coats of asphalt paint conforming to Section 1060.07 Type II or place 1/2" fabric bearing pads between the plates and concrete. The 3/4" ϕ high strength bolts used to connect the 6 x 4 x 3/4 angles to the post shall be tightened according to Article 505.04(FX2) of the Standard Specifications. The 1" ϕ high strength bolts connecting the angles to the concrete shall be tightened to a snug fit and given an additional 1/8 turn. The 5/8" ϕ cap screws in bottom of posts shall be tightened to a snug fit only.

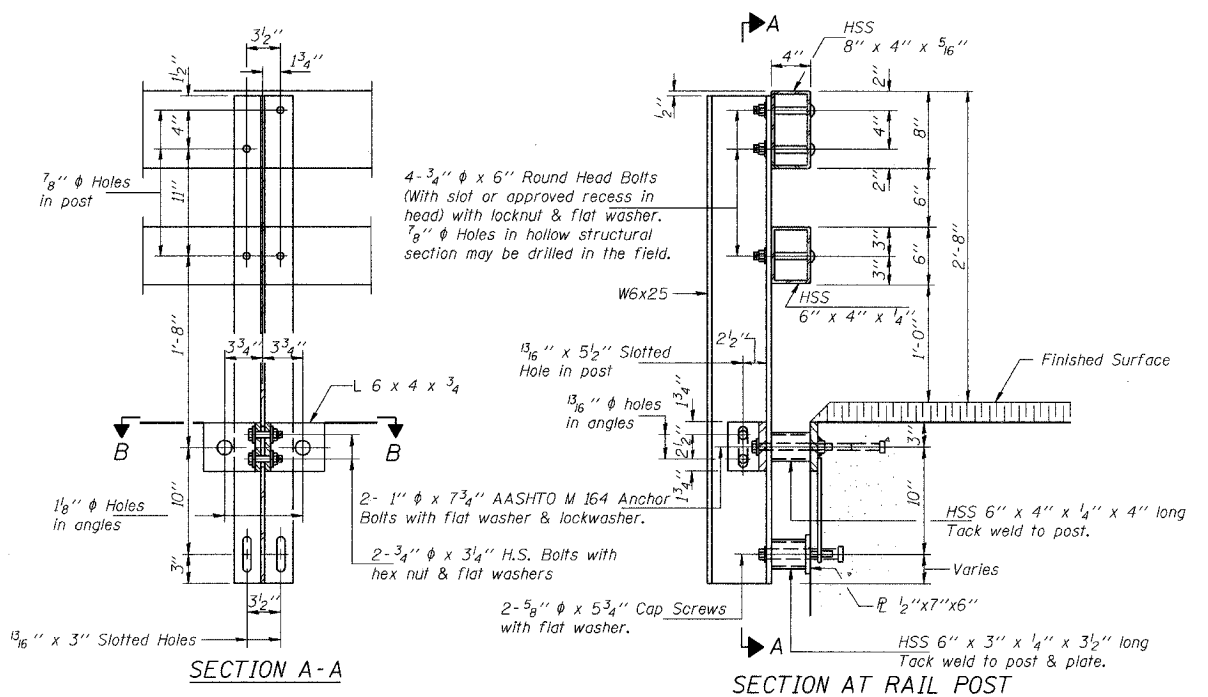

SECTION A-A

SECTION AT RAIL POST

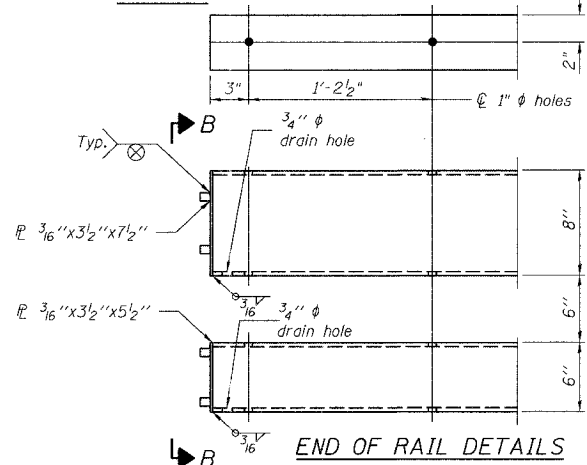

END OF RAIL DETAILS

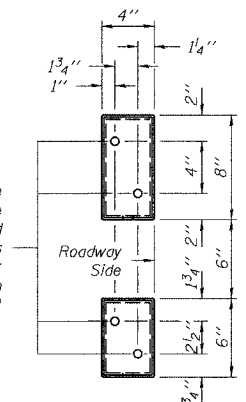

VIEW B-B

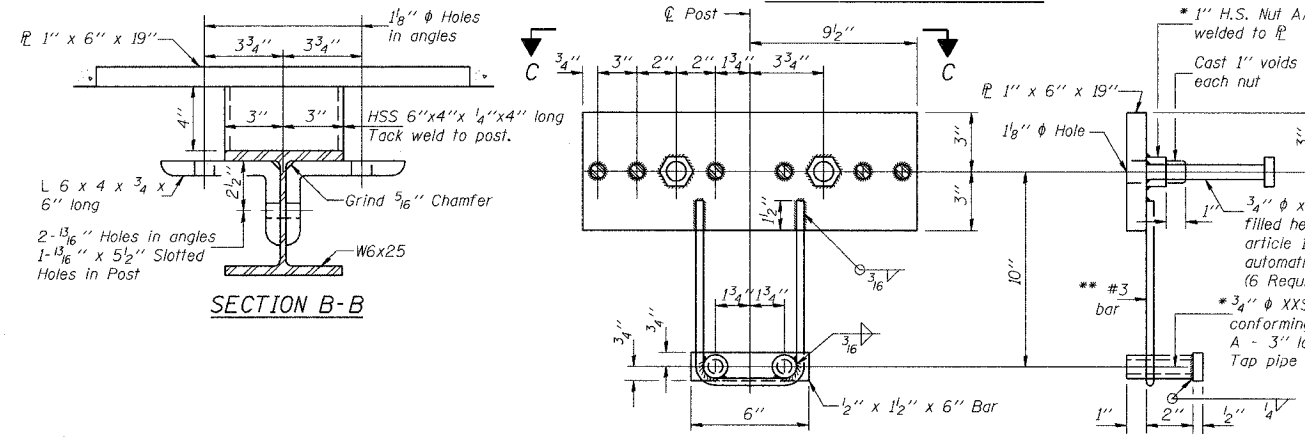

ANCHOR DEVICE

* Threaded areas shall be plugged or blocked off during casting of beam. Galvanized after fabrication.
** Whenever the lower insert assemblies interfere with strand locations, the #3 bars shall be cut and adjusted in order to allow raising or lowering of the lower inserts. Maximum adjustment not to exceed 1/2".

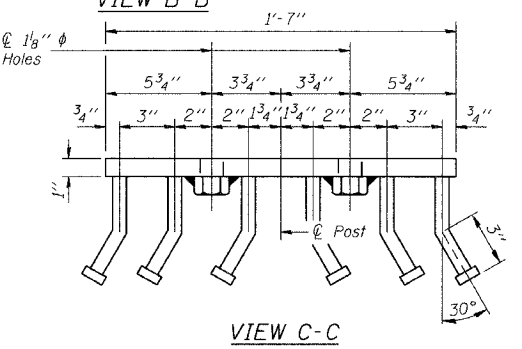

VIEW C-C

BILL OF MATERIAL

Item	Unit	Quantity
Steel Bridge Rail, Type SM	Foot	135

TYPE SM STEEL BRIDGE RAIL SIDE MOUNTED

STEEL RAILING			Sheet No.
Date	Designed MJP	C.H. 20 OVER DRAINAGE DITCH SECTION 05-00195-00-BR MACON COUNTY STA. 15+66.99 PROP. STR. NO. 058-3377	3
Revisions	Drawn MLS		
	Checked KWB		
	Approved KWB		
Prepared by:	URS		
345 East Ash Avenue Decatur, IL 62526			of 6 URS Job No. 36431466