

FAP RTE.	SECTION	COUNTY	TOTAL SHEETS	SHEET NO.
331	3-2, 8X-1, 4-2	SALINE	233	146
STA.		TO STA.		
FED. ROAD DIST. NO.		ILLINOIS FED. AID PROJECT		

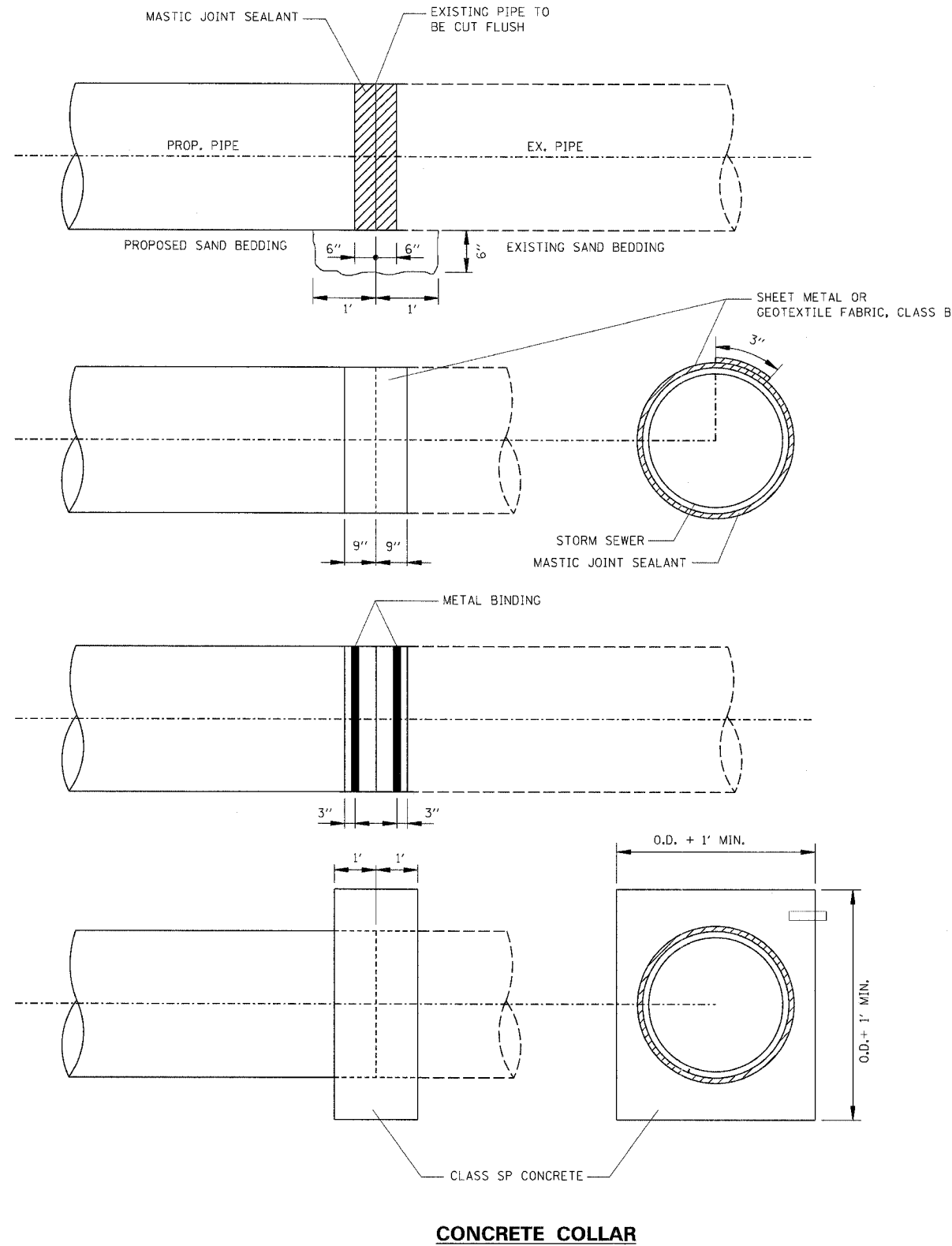

CONSTRUCTION SEQUENCE

1. CUT THE EXISTING END OF THE PIPE SO AS TO PRESENT A FLUSH BUTT JOINT. BRUSH AND CLEAN ALL PIPES.
2. APPLY THE MASTIC JOINT SEALANT TO THE FIRST 6" OF EACH PIPE.
3. BUTT THE PIPES TOGETHER LEAVING A MINIMUM OF 1' X 6" DEEP EXCAVATION UNDER AND AROUND EACH PIPE END.
4. CUT SHEET METAL GAGE 19 OR GEOTEXTILE FABRIC CLASS B 1.5' WIDE AND THE LENGTH OF THE OUTSIDE CIRCUMFERENCE OF THE PIPE PLUS 3" LONG.
5. WRAP THE SHEET METAL OR GEOTEXTILE FABRIC CLASS B AROUND THE PIPES, 9" ON EACH SIDE OF THE JOINT, STARTING AT THE TOP OF THE PIPE.
6. LAP THE SHEET METAL OR GEOTEXTILE FABRIC CLASS B, AT LEAST 3" AT THE TOP OF THE PIPE AND PLACE THE MASTIC JOINT SEALANT BETWEEN THE LAP.
7. PLACE TWO METAL BANDS AROUND THE SHEET METAL AND TIGHTEN.
8. WIPE OFF ANY EXCESS MASTIC JOINT SEALANT THAT OOZES OUT FROM BETWEEN THE SHEET METAL OR GEOTEXTILE FABRIC CLASS B AND THE PIPES.
9. PLACE CONCRETE AROUND THE JOINT.

GENERAL NOTES:

1. WHEN THE CONNECTION LOCATION SHOWN ON THE PLANS IS WITHIN 2' OF AN EXISTING JOINT, GO TO THE EXISTING JOINT.
2. CARE MUST BE TAKEN TO PREVENT DEBRIS FROM ENTERING THE PIPE CULVERT. ALL DEBRIS WHICH ENTERS THE PIPE CULVERT MUST BE REMOVED. THE PIPE CULVERT MUST BE LEFT CLEAN AND UNOBSTRUCTED UPON COMPLETION OF THE CONTRACT.
3. CARE MUST BE TAKEN TO PREVENT ANY PART OF THE NEW PIPE CONNECTION FROM PROJECTING INTO THE EXISTING PIPE CULVERT.

DRAWN BY JS
CHECKED BY DB

MUT 3556/ROADWAY/CONTRACT 1/STANDARDS/	Reference Files	GT00003556.dgn
ACT. FILE		
STUD. FILE		