

F.A.I. RTE.	SECTION	COUNTY	TOTAL SHEETS	SHEET NO.
155		TAZEWELL	27	16
STA. 18+89.42 TO STA. 21+10.58				
FED. ROAD DIST. NO. 4 ILLINOIS FED. AID PROJECT				
* 04 Joint Repair 2006				

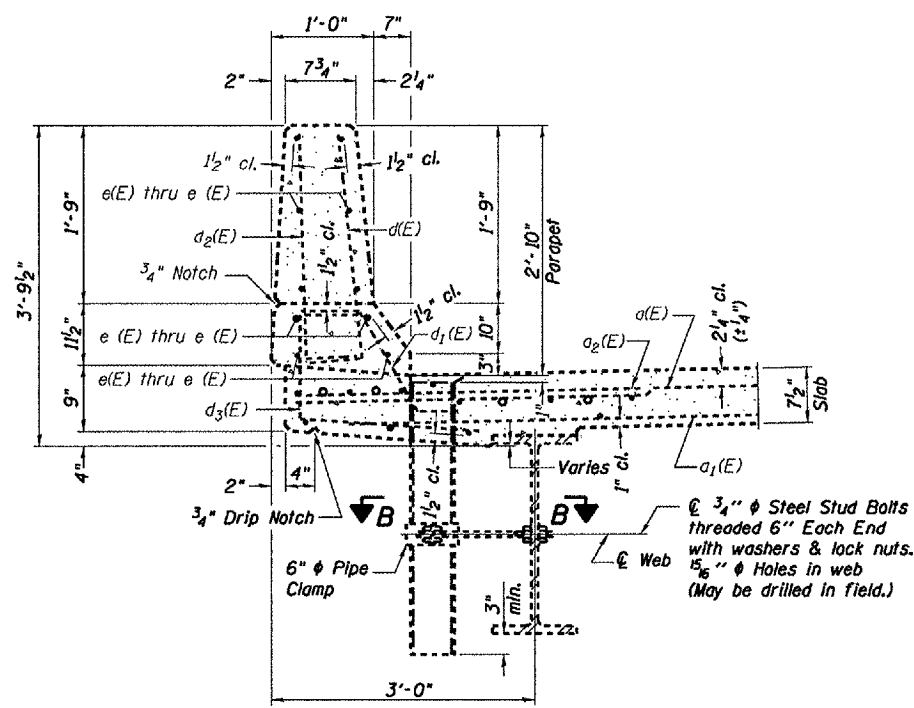

**SECTION THRU PARAPET**

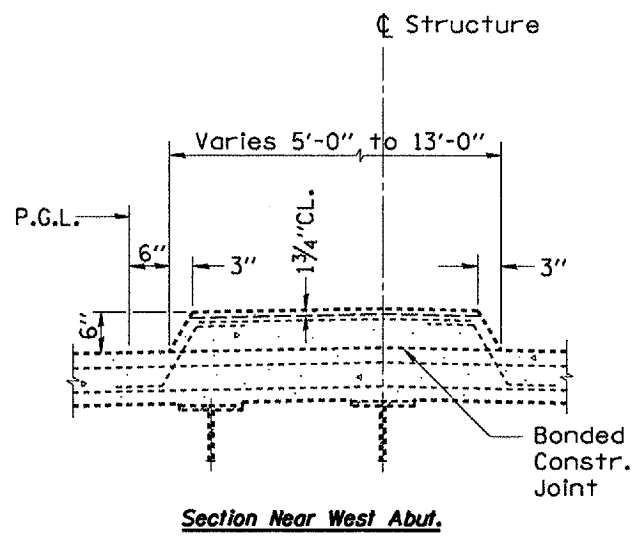

**Section Near West Abut.**

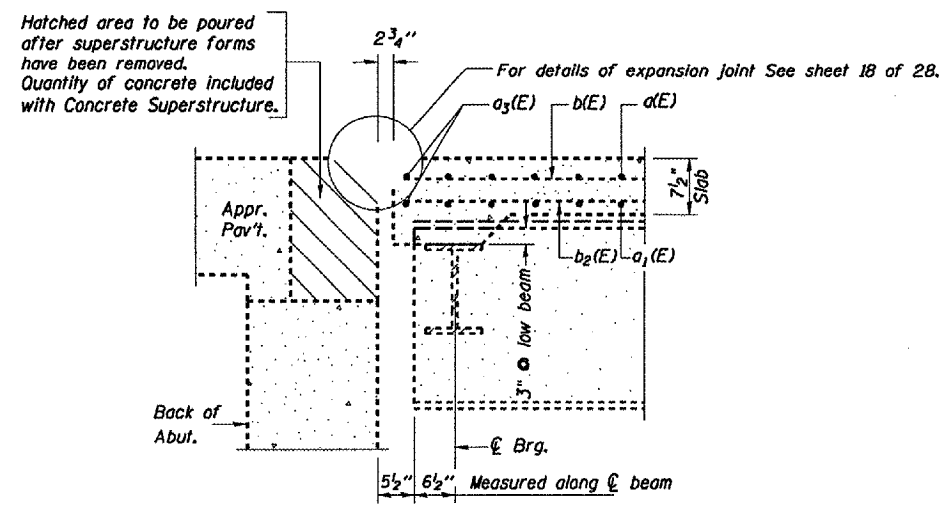

**SECTION A-A**

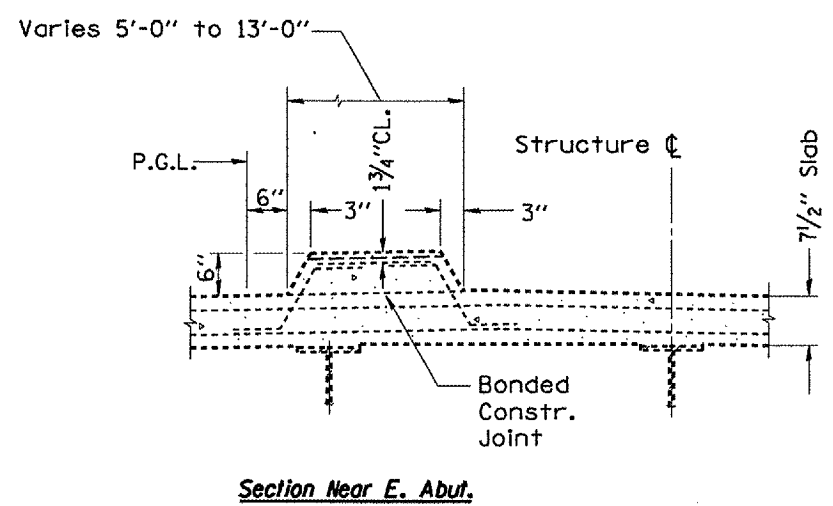

**Section Near E. Abut.**

FOR INFORMATION ONLY

PLT DATE \* STATES  
FILE NAME \* FILES  
PLOT SCALE \* SCALES  
REFERENCE \* REF

REVISIONS	
NAME	DATE

ILLINOIS DEPARTMENT OF TRANSPORTATION  
**SUPERSTRUCTURE DETAILS**  
SCALE: VERT. DATE 06-16-2005  
DRAWN BY CEJ  
CHECKED BY

S.N. 090-0130  
Queenwood Rd.  
over I-155