

F.A.P. RTE.	SECTION	COUNTY	TOTAL SHEETS	SHEET NO
331	(12-1) RS-1	JACKSON	16	11
STA.		TO STA.		
FED. ROAD DIST. NO.		ILLINOIS	FED. AID PROJECT	
CONTRACT NO. 98904				

DETAIL OF INTERSECTION RESURFACING

STA 128+55
LAKE ROAD

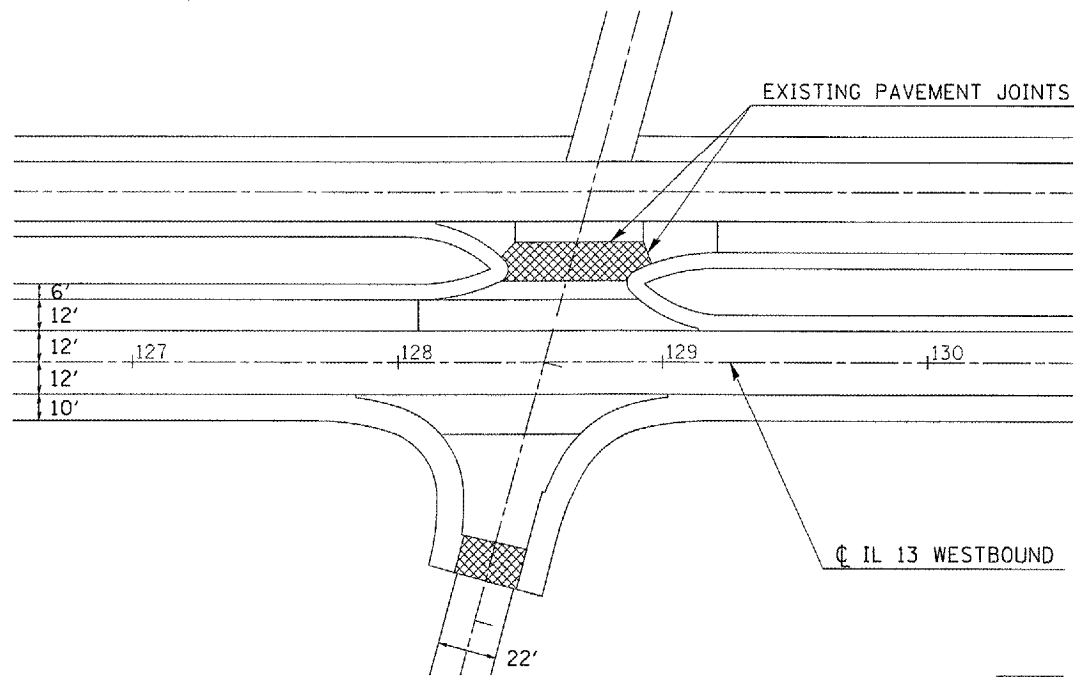

DETAIL OF INTERSECTION RESURFACING

STA 160+50
WOOD ROAD

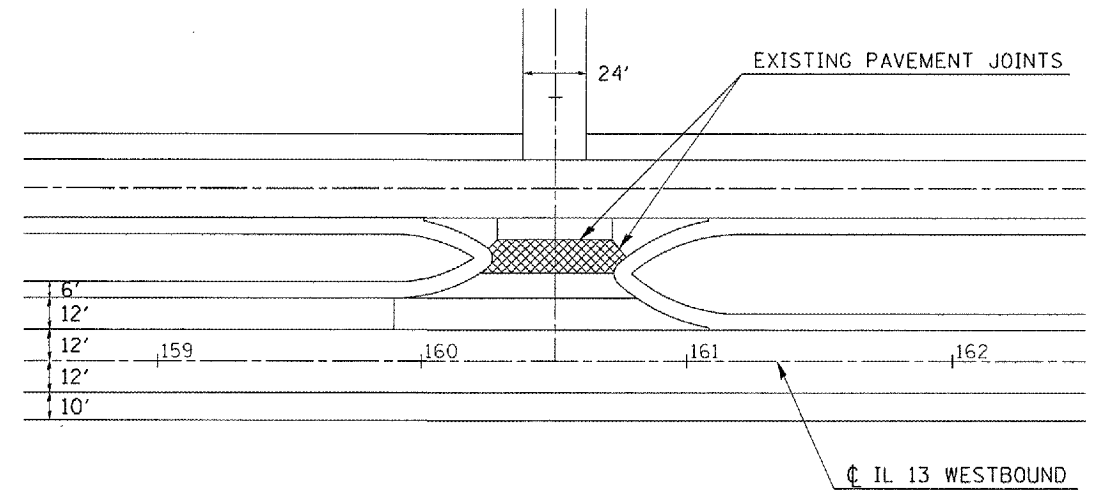

PCC SURFACE REMOVAL, BUTT JOINT

DETAIL OF INTERSECTION RESURFACING

STA 188+54
AIRPORT ROAD

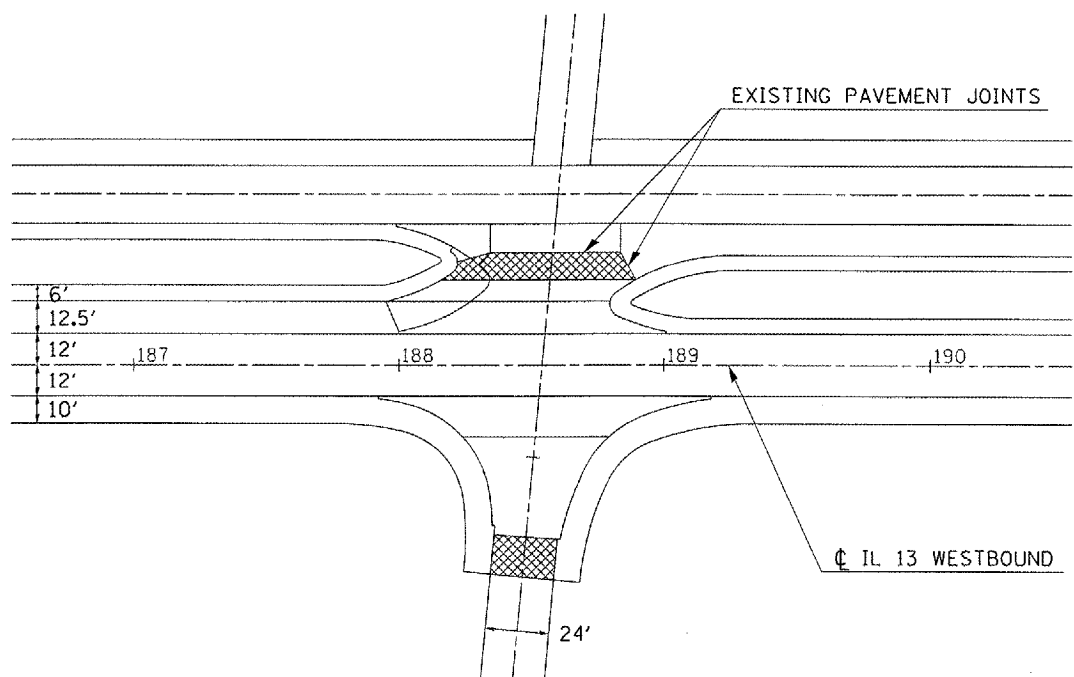

DETAIL OF INTERSECTION RESURFACING

STA 216+55
COUNTRY CLUB ROAD

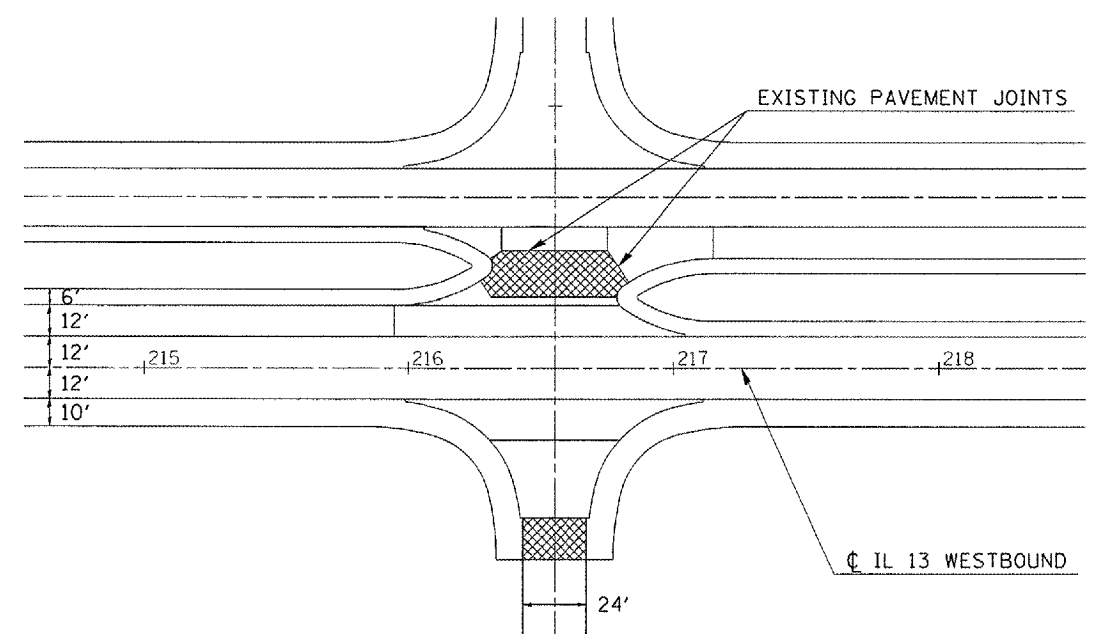

PLOT DATE = 10/3/2005
FILE NAME = c:\projects\901005\901005.ms.m32
PLOT SCALE = 108.4337' / IN.
USER NAME = thomashf