

STATE OF ILLINOIS
DEPARTMENT OF TRANSPORTATION

CONTRACT NO. 98940
ROUTE FAI-57
(02-1B-1) P1
ALEXANDER COUNTY
SHEET 66 OF 67

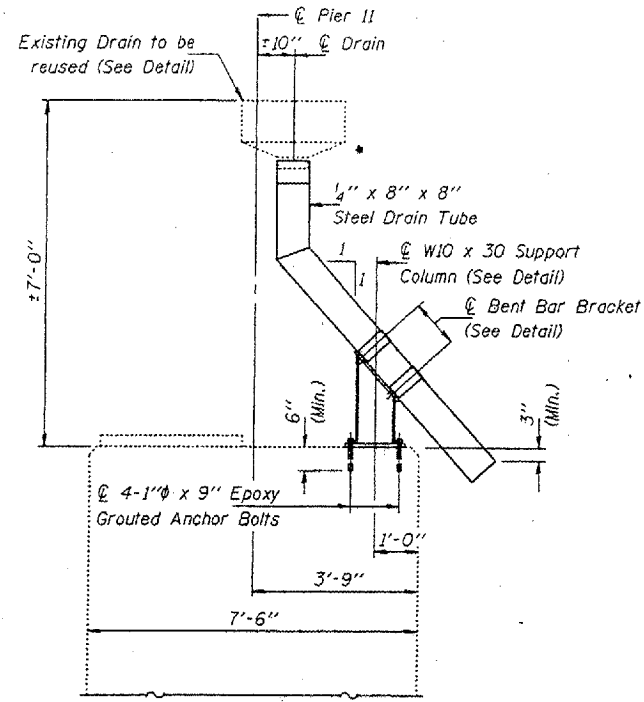

ELEVATION - PIER 11

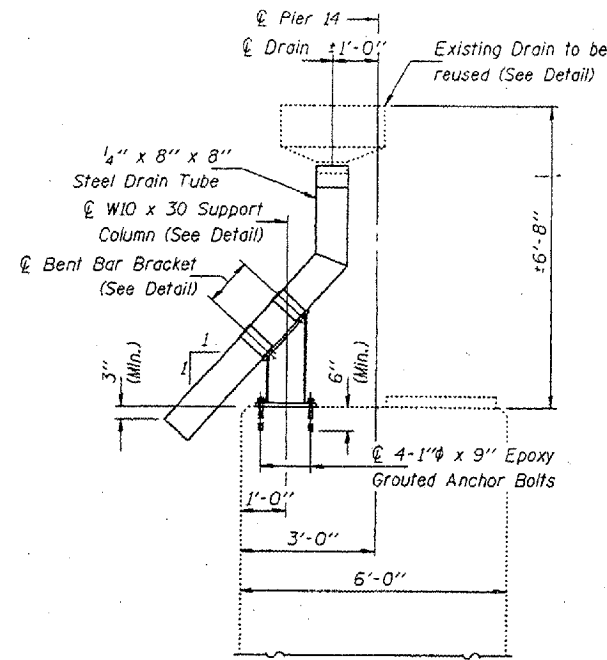

ELEVATION - PIER 14

Note: Place 1/8" thick Neoprene around Drain Tube at Bracket locations.

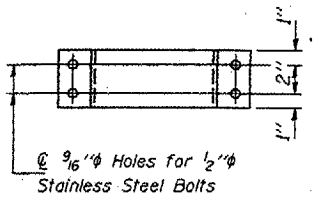
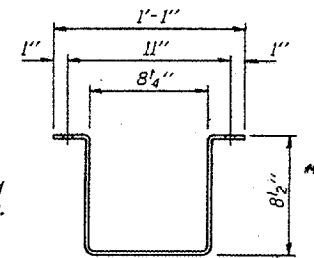

BENT BAR BRACKET

DETAIL

1/4" x 4" x 2'-5"
(No. Req'd. = 4)

Notes:
The 1/4" x 8" x 8" Structural Steel Tubing shall conform to the requirements of ASFM designation A-500, Grade B, Structural Steel Tubing.
Steel tubing shall be galvanized in accordance with AASHTO M111 and ASTM A-385. Cost included with Drain System.
Existing 1/4" x 8" x 8" Steel Drain Tubes may be re-used for new Drainage System, as directed by the Engineer.

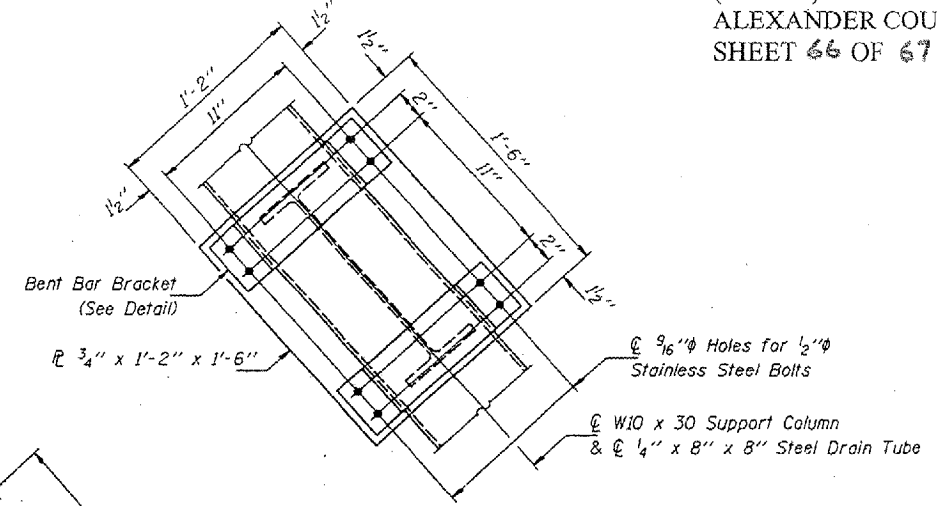

VIEW G-G

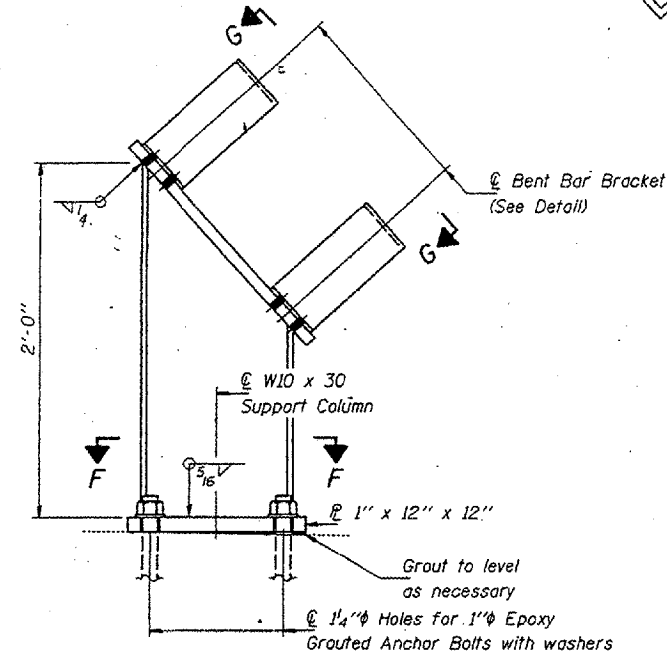

SUPPORT COLUMN
(No. Req'd. = 2)

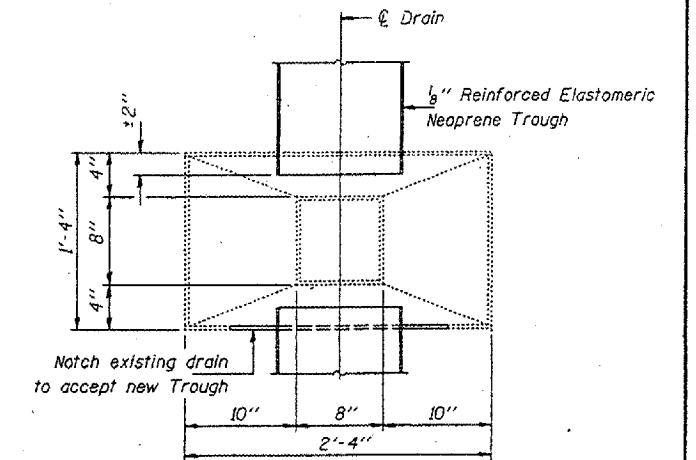

TOP VIEW

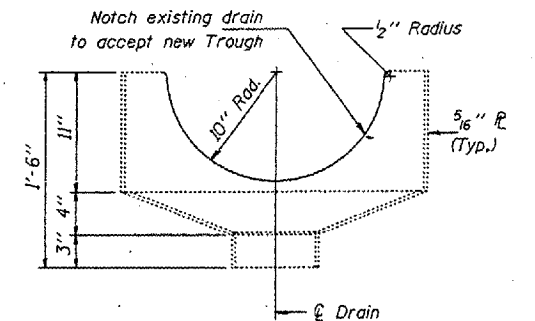

DRAIN ELEVATION

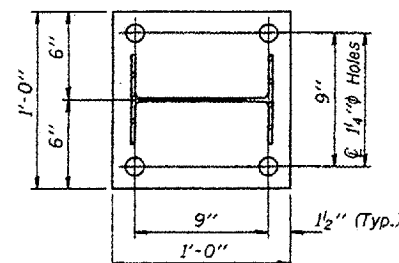

SECTION F-F

BRIDGE NO. 1
STRUCTURE NO. 002-0022
FOR INFORMATION ONLY

DRAIN SYSTEM - PIER 11 & 14
F.A.I. 57 OVER MISSISSIPPI RIVER
ALEXANDER COUNTY
S.N. 002-0022

DESIGNED	P.S.J.	FEBRUARY 4,	2002
CHECKED	A.T.H.	EXAMINED	<i>John A. Morris</i>
DRAWN	John F. Schneller Jr.	PASSED	ENGINEER OF STRUCTURAL SERVICES
CHECKED	P.S.J. A.T.H.		ENGINEER OF BRIDGES AND STRUCTURES