

**ELEVATION
TYPICAL INTERIOR UNIT**
Even number of panels/interior unit required.

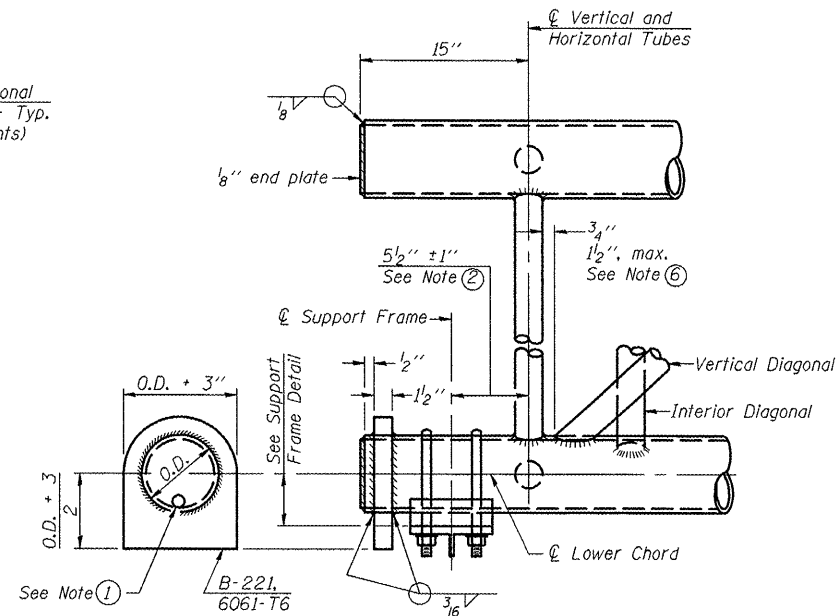

SUPPORT END DETAIL FOR EXTERIOR UNIT

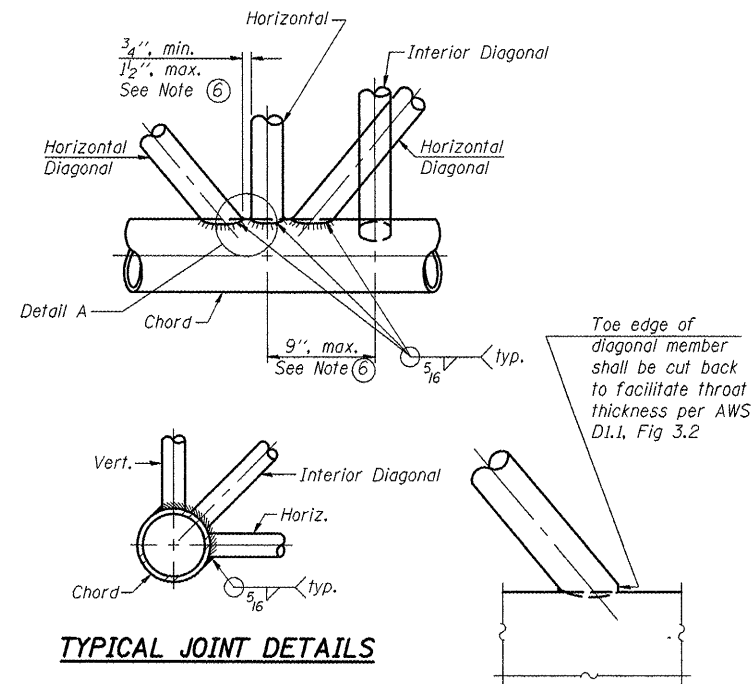

TYPICAL JOINT DETAILS

DETAIL A

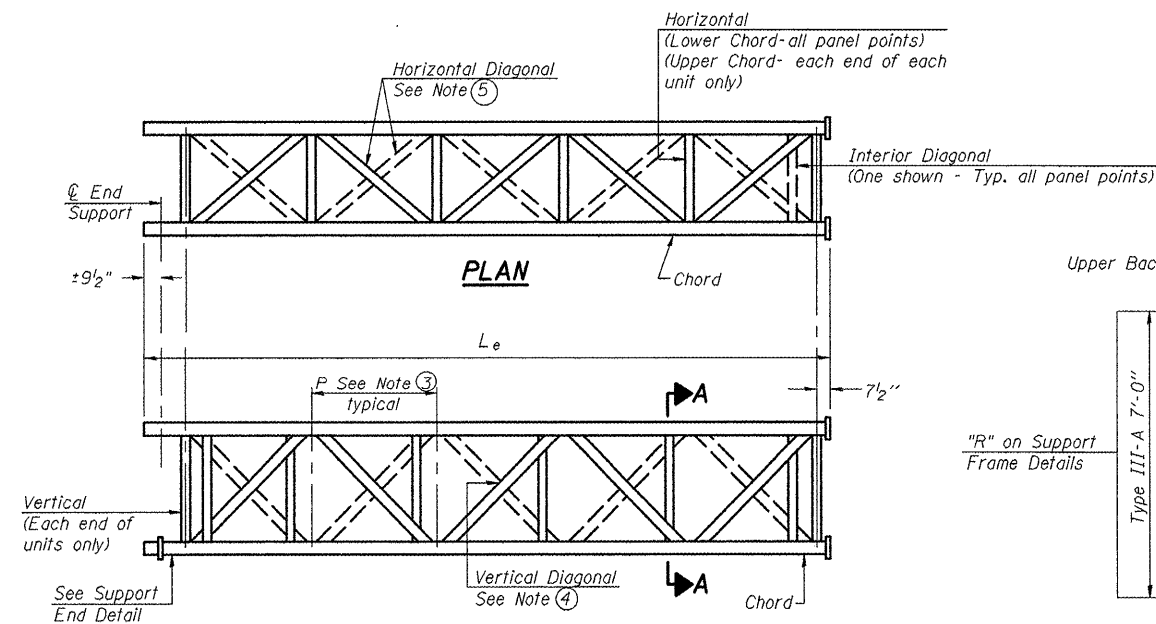

**ELEVATION
TYPICAL EXTERIOR UNIT**
Even or odd number of panels/exterior units allowed.

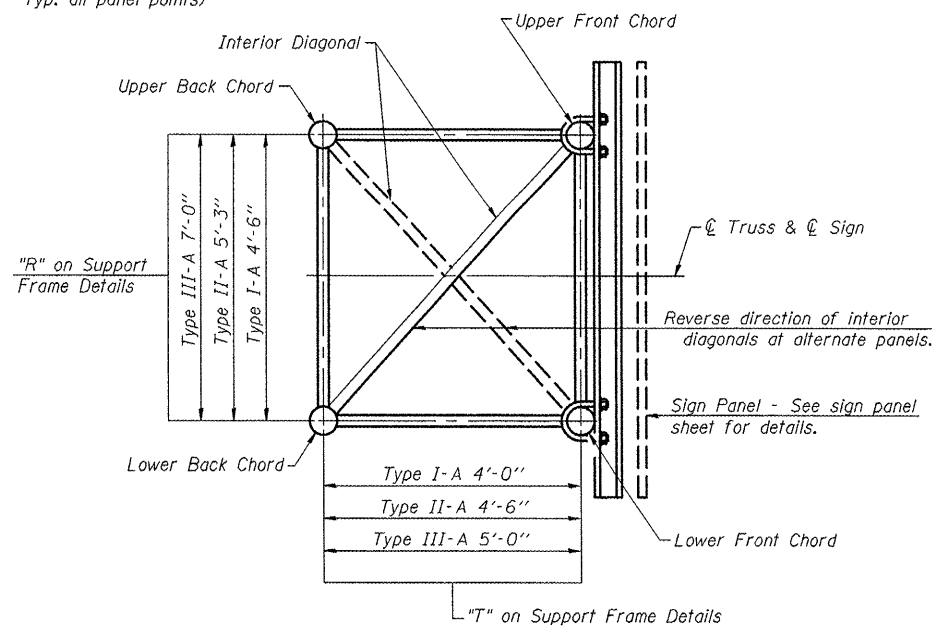

SECTION A-A

- ① Contractor may alternatively use standard aluminum drive-fit cap to close end. 1/2" ϕ drain hole in end plate/drive-fit cap. (Typ. at ends of all chords)
- ② 5 1/2" end dimension may vary by $\pm 1"$ to provide uniform panel spacing (P).
- ③ Panel spacing (P) shall be uniform for entire truss and between 4'-0" and 5'-0" for Type I-A or 4'-0" and 5'-6" for Types II-A and III-A.
- ④ Vertical Diagonals in front and back face shall alternate.
- ⑤ Hidden lines show wind bracing alternates direction between planes of top and bottom chords.
- ⑥ All diagonals shall be detailed for minimum offset from the panel point based on the following: Offset shall be such as to provide a 3/4" minimum to 1 1/2" maximum clearance between any diagonal and any horizontal or vertical member, and to provide clearance for U-bolt connections of signs or walkway brackets.

OS-A-2 1-20-11

FILE NAME =	USER NAME = ceerlockjd	DESIGNED - JAL	REVISED -	STATE OF ILLINOIS DEPARTMENT OF TRANSPORTATION	OVERHEAD SIGN STRUCTURES - ALUMINUM TRUSS DETAILS FOR TRUSS TYPES I-A, II-A AND III-A	F.A. RTE.	SECTION	COUNTY	TOTAL SHEETS	SHEET NO.
ce:\pwr\work\pvidot\ceerlockjd\0266557\0546179-shr-details.dgn	PLOT SCALE = 40.0000' / 1"	DRAWN -	REVISED -			•	**	Various	178	71
PLOT DATE = 10/7/2011	DATE = 04/26/11	CHECKED -	REVISED -			CONTRACT NO. 46179				
		DATE -	REVISED -			ILLINOIS FED. AID PROJECT				
					SCALE:	SHEET NO. 4 OF 24 SHEETS	STA.	TO STA.		

•VARIOUS COUNTIES
••D-5 OVD SIN STR REPL 2012-06