

EXISTING TYPICAL SECTION  
ILL 113 (RIVER ST.)  
STA. 201+11 TO STA. 264+67.5

- LEGEND**
- ① EXISTING PCC PAVEMENT,  $\pm 8\frac{3}{4}$  "
  - ② EXISTING HOT-MIX ASPHALT SURFACE COURSE AFTER MILLING  $\pm 2\frac{1}{4}$  "
  - ③ EXISTING AGGREGATE SHOULDER
  - ④ EXISTING COMBINATION CONCRETE CURB AND GUTTER
  - ⑤ PROPOSED HOT-MIX ASPHALT SURFACE REMOVAL,  $2\frac{1}{4}$  "
  - ⑥ PROPOSED HOT-MIX ASPHALT SURFACE COURSE, MIX "D", N50,  $1\frac{1}{2}$  "
  - ⑦ PROPOSED POLYMERIZED LEVELING BINDER (MACHINE METHOD), IL-4.75, N50,  $\frac{3}{4}$  "
  - ⑧ PROPOSED POLYMERIZED LEVELING BINDER (MACHINE METHOD), IL-4.75, N50, 1"
  - ⑨ PROPOSED AGGREGATE WEDGE SHOULDER, TYPE B
  - ⑩ PROPOSED SAFETY EDGE (WHEN HMA SHOULDER < 3 FT)
  - ⑪ PROPOSED GRADING AND SHAPING SHOULDER

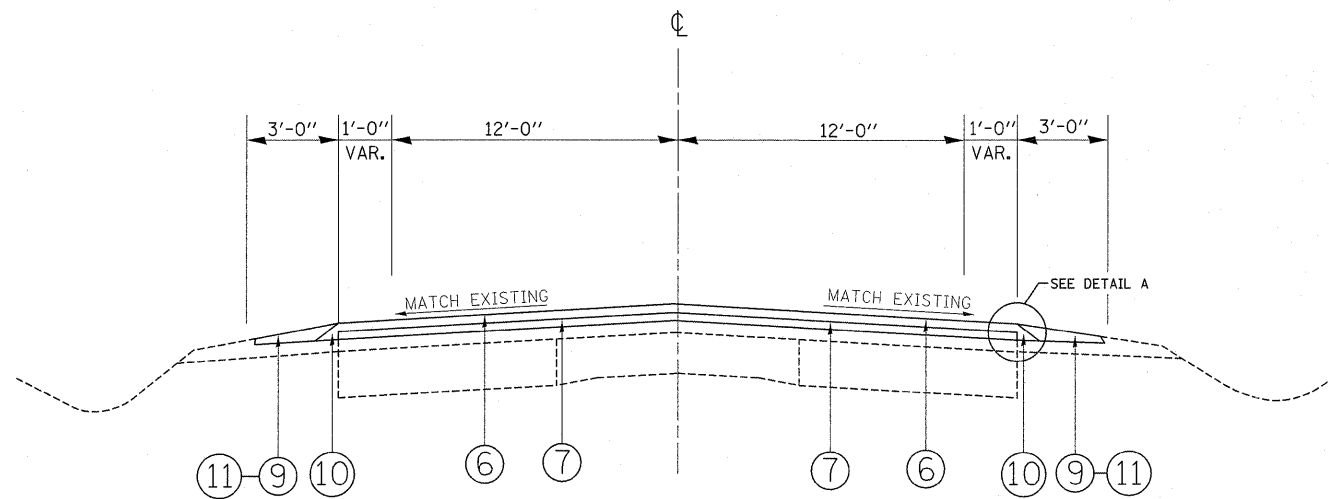

PROPOSED TYPICAL SECTION  
ILL 113 (RIVER ST.)  
STA. 201+11 TO STA. 264+67.5

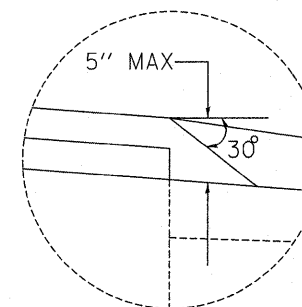

DETAIL A

**THE CONTRACTOR SHALL MILL FIRST  
BEFORE PATCHING**

FILE NAME =	USER NAME = mdyje	DESIGNED -	REVISED -	<b>STATE OF ILLINOIS DEPARTMENT OF TRANSPORTATION</b>	<b>ILL 113 (RIVER ST.) EXISTING &amp; PROPOSED TYPICAL SECTIONS</b>	F.A.U. RTE.	SECTION	COUNTY	TOTAL SHEETS	SHEET NO.	
ca\pvc_work\pvc\dot\mdyje\d0275811\sh-t-pln.dgn	PLOT SCALE = 50.0000' / 1" =	DRAWN -	REVISED -			0327	111-RS-9	WILL	17	5	
	PLOT DATE = 10/19/2011	CHECKED -	REVISED -			CONTRACT NO. 60P71					
		DATE -	REVISED -			ILLINOIS FED. AID PROJECT					
					SCALE:	SHEET NO.	OF	SHEETS	STA.	TO STA.	