

F.A.P. RTE.	SECTION	COUNTY	TOTAL SHEETS	SHEET NO.
307	130 R-2		647	88

STA.	TO STA.
FED. ROAD DIST. NO. 1	ILLINOIS FED. AID PROJECT

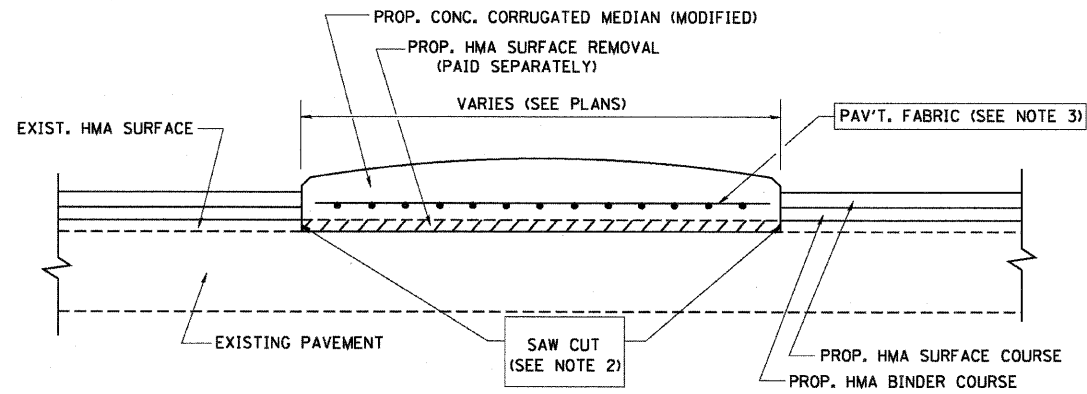

- NOTES:
1. CORRUGATED MEDIAN (MODIFIED) SHALL BE CONSTRUCTED IN ACCORDANCE WITH SECTION 606 OF THE STANDARD SPECIFICATIONS AND THE APPLICABLE PORTIONS OF STATE STANDARD 606306.
  2. WITH THE APPROVAL OF THE ENGINEER, THE CONTRACTOR MAY DELETE THE SAW CUT IF A NEAT JOINT CAN BE OBTAINED BY MILLING THE HMA SURFACE TO BE REMOVED. SAW CUT WILL BE INCLUDED IN THE COST OF CORRUGATED MEDIAN (MODIFIED)
  3. PAVEMENT FABRIC WILL BE INCLUDED IN THE COST OF CORRUGATED MEDIAN (MODIFIED)

**DETAILS FOR CORRUGATED MEDIAN (MODIFIED)**

THIS WORK WILL BE PAID FOR AT THE CONTRACT UNIT PRICE PER SQUARE FOOT (SQUARE METER) FOR "CORRUGATED MEDIAN (MODIFIED)"

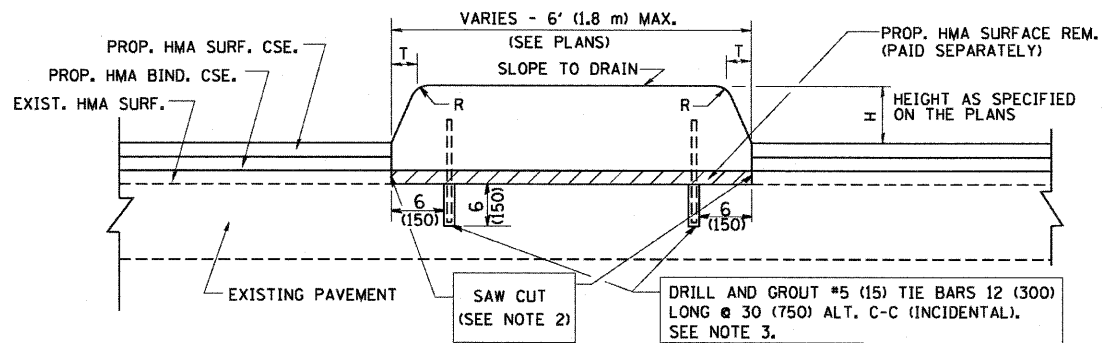

- NOTES:
1. CONCRETE MEDIAN TYPE SB (DOWELLED) SHALL BE CONSTRUCTED IN ACCORDANCE WITH THE APPLICABLE PORTIONS OF STATE STANDARD 606301 AND SECTION 606 OF THE STANDARD SPECIFICATIONS.
  2. WITH THE APPROVAL OF THE ENGINEER, THE CONTRACTOR MAY DELETE THE SAW CUT IF A NEAT JOINT CAN BE OBTAINED BY MILLING THE HMA SURFACE TO BE REMOVED. SAW CUT WILL BE INCLUDED IN THE COST OF "CONCRETE MEDIAN TYPE SB (DOWELLED)"
  3. FOR MEDIAN WIDTH LESS THAN 4' (1.2 m) USE ONE ROW OF #5 (15) BARS @ 30 (750) C-C ALONG THE MEDIAN CENTERLINE. TIE BARS WILL BE INCLUDED IN THE COST OF "CONCRETE MEDIAN TYPE SB (DOWELLED)"

H	R	T
6(150)	1(25)	1(25)
9(225)	1(25)	2(50)

**DETAILS FOR CONCRETE MEDIAN  
TYPE SB (DOWELLED)**

THIS WORK WILL BE PAID FOR AT THE CONTRACT UNIT PRICE PER SQUARE FOOT (SQUARE METER) FOR "CONCRETE MEDIAN TYPE SB (DOWELLED)"

ALL DIMENSIONS ARE IN INCHES (MILLIMETERS) UNLESS OTHERWISE SHOWN.

REVISIONS	
NAME	DATE
M. DE YONG	05/14/90
M. DE YONG	06/13/90
M. DE YONG	06/14/90
M. DE YONG	06/20/90
M. DE YONG	09/21/90
M. DE YONG	10/12/90
R. SHAH	09/09/94
R. SHAH	10/25/94
E. GOMEZ	08/28/00
R. BORO	01/01/07

ILLINOIS DEPARTMENT OF TRANSPORTATION  
DETAILS FOR  
CONCRETE MEDIAN TYPE SB (DOWELLED)  
CORRUGATED MEDIAN (MODIFIED)

SCALE: VERT. NONE  
HORIZ.

DRAWN BY  
CHECKED BY