

FOOTING PLAN - PIERS 1 - 5

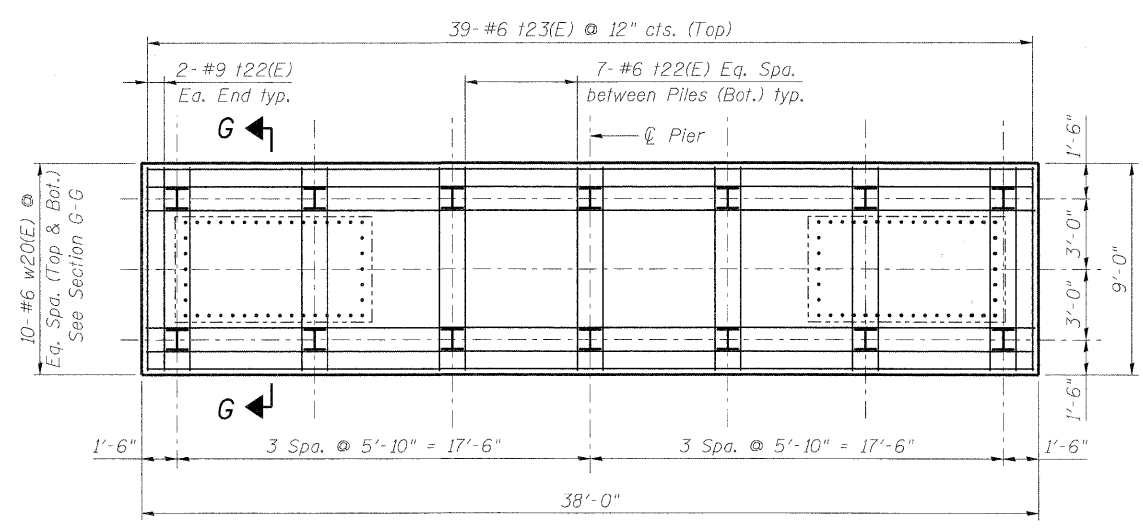

FOOTING PLAN - PIERS 6 & 7

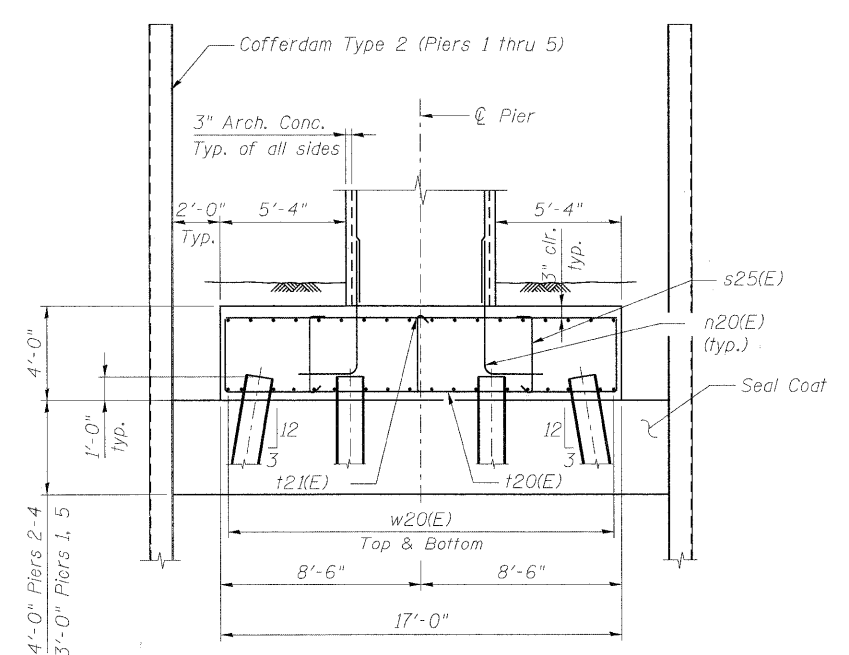

SECTION F-F

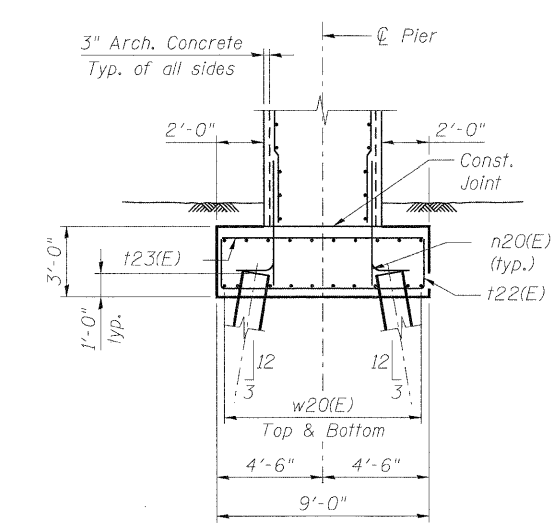

SECTION G-G

- NOTES:**
1. See sheet S41 thru S43 for pier plan and elevations.
 2. See sheet S44 for pier sections.
 3. For Bill of Materials, see sheet S46 and S47.

benesch
engineers · scientists · planners
Alfred Benesch & Company
205 North Michigan Avenue, Suite 2400
Chicago, Illinois 60601
312-565-0450 Job No. 10092

FILE NAME = 0456024_045_FtgDet.dgn
USER NAME = akoeschall
DESIGNED - MFH
CHECKED - AJK
DRAWN - RMG
PLOT DATE = 11/9/2011

REVISIONS
REVISOR
DATE
REVISIONS
REVISOR
DATE



CITY OF ST. CHARLES

FOOTING DETAILS
STRUCTURE NO. 045-6024 RED GATE ROAD OVER THE FOX RIVER
SHEET NO. S45 OF S56 SHEETS

F.A.I. RTE.	SECTION	COUNTY	TOTAL SHEETS	SHEET NO.
	04-00092-00-BR	KANE	440	267
				CONTRACT NO. 63650
ILLINOIS FED. AID PROJECT				