

Stage 1 and 3 Plan and Elevation

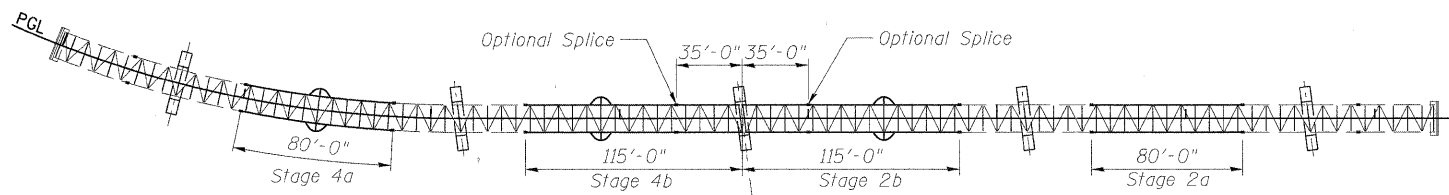
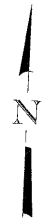
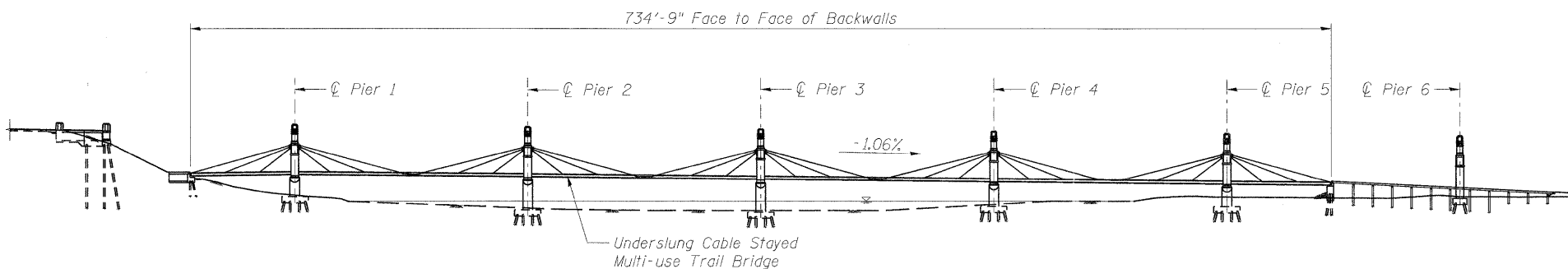

Stage 2 and 4 Plan and Elevation

PROPOSED ERECTION SEQUENCE

(Contractor may propose an alternate sequence and shall submit an erection plan for approval regardless of what sequence is selected.)

1. The upper anchorage assemblies in the pier shall be installed and the bolts pre-tensioned prior to installation of the cable stays.
2. Assemble span 6 and the eastern 35' of span 5 in a staging area near the bridge. All floor beams and bracing shall be installed (100% bolts finger tight). Bearings shall be blocked against lateral and rotational movement (typical).
3. Set the pre-assembled span 6 and partial span 5 (approximately 33,000 lbs) and connect all stay cables prior to releasing the steel from the crane.
4. Pre-assemble all steel for the 70' bridge segment that extends through pier 4 in a staging area near the bridge.
5. Set the pre-assembled pier segment that extends through pier 4 (approximately 21,000 lbs) which will require re-connecting the rigging once prior to final setting. Connect the remaining cable stays prior to releasing the segment from the crane.
6. Set the remaining girder 1 segment in span 5. Bolt each field splice with a minimum of 50% of the bolts in the web and flange plates (typical for all erection splice connections). Connect the cable stays prior to releasing the load from the crane. Repeat for the remaining girder 2 segment in span 5.
7. Splice the two remaining girder 1 segments (100% bolted) for span 4 prior to lifting the girder. Set the remaining girder 1 segment in span 4. Block the girder end at pier 3 to ensure stability against rotation and lateral deflection. Make the splice connection and then connect the cable stays prior to releasing the load from the crane.
8. Splice the remaining girder 2 segments (100% bolted) and set the remaining portion of girder 2 in span 4. Block the girder end at pier 3 to ensure stability against rotation and lateral deflection. Make the splice connection and then connect the end diaphragm (W12x30) at pier 3. After the end diaphragm is connected, make the cable stay connections prior to releasing the crane.
9. Install all remaining floor beams and lateral bracing (finger tight bolted) working outward from the pre-assembled segments. Come-alongs will be required to ensure the girders are plumb and in the correct lateral position prior to connecting the floor beams.
10. Adjust open end bridge sockets to ensure top of girder elevations meet the values outlined on sheet SM14 for the floor beams at the cable stay anchorage locations. Install remaining bolts of splice connections and conduct final tightening at the splices.
11. Adjust vertical elevations of all remaining floor beams to meet the top of steel elevations as shown on sheet SM14. Conduct final tightening of all bolts.
12. Repeat the same operation for spans 1 through 3 working from the west abutment eastward.

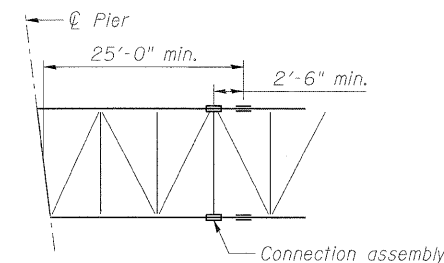

Splice Location Detail

1. Contractor may relocate splices to facilitate erection, but must request approval from Engineer.
2. No splices shall be located within 25'-0" of the centerline of the pier or within 2'-6" of a floor beam.
3. No more than 2 splices may be placed in any single span.

benesch Alfred Benesch & Company
 engineers - scientists - planners
 205 North Michigan Avenue, Suite 2400
 Chicago, Illinois 60601
 312-565-0450 Job No. 10092

FILE NAME =	USER NAME = akeschall	DESIGNED - MJF	REVISED -
2456020.13.SteelErection.dgn		CHECKED - AJK	REVISED -
	PLOT SCALE =	DRAWN - RMG	REVISED -
	PLOT DATE = 11/10/2011	CHECKED - HMA	REVISED -



CITY OF ST. CHARLES

STEEL ERECTION PLAN
STRUCTURE NO. 045-6020 MULTI-USE TRAIL BRIDGE OVER FOX RIVER
 SHEET NO. SM13 OF SM19 SHEETS

F.A.I. RTE.	SECTION	COUNTY	TOTAL SHEETS	SHEET NO.
	04-00092-00-BR	KANE	440	291
				CONTRACT NO. 63650
ILLINOIS FED. AID PROJECT				

x:\10000s\10092\engineering\documents_redgatephase11\pedbr\ridgeoverfoxriver\final\plans\0456020.13.SteelErection.dgn

4:12:53 PM

11/10/2011