

FINAL SURVEY	SURVEYED	BY	DATE
NOTE BOOK	PLOTTED		
NO.	EMPLATE		
	AREAS CHECKED		

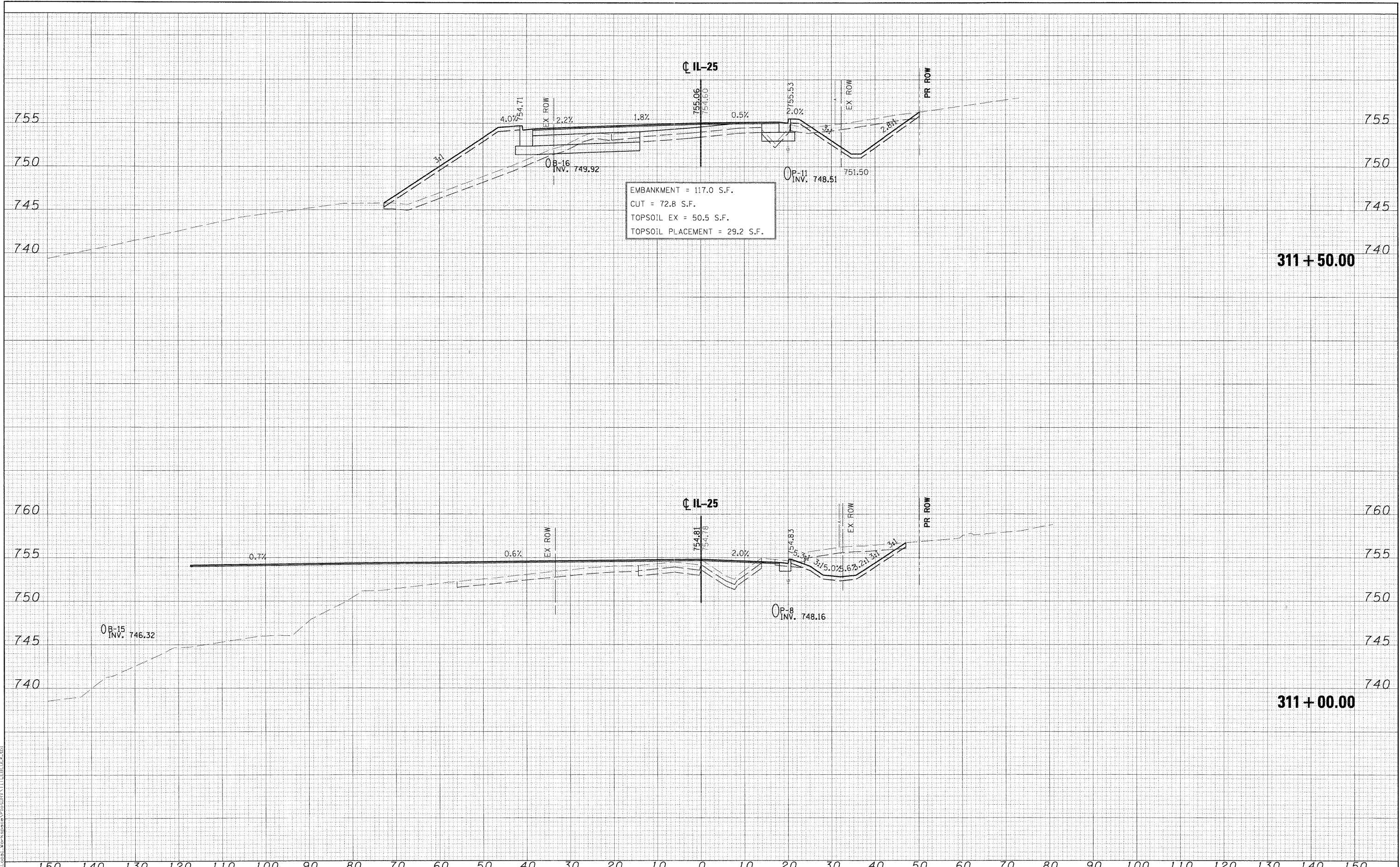

ORIGINAL SURVEY	SURVEYED	BY	DATE
NOTE BOOK	PLOTTED		
NO.	EMPLATE		
	AREAS CHECKED		

FILE NAME = ...
 USER NAME = mooleman
 PLOT DATE = 11/22/2011

DESIGNED -	MAC	REVISED -	
DRAWN -	TMB	REVISED -	
CHECKED -	RMT	REVISED -	
DATE -	10/23/2011	REVISED -	



CITY OF ST. CHARLES

IL 25
 CROSS-SECTIONS
 SCALE: SHEET NO. 17 OF 23 SHEETS STA. 311+00.00 TO STA. 311+50.00

F.A. RTE.	SECTION	COUNTY	TOTAL SHEETS	SHEET NO.
	04-00092-00-BR	KANE	440	401
			CONTRACT NO. 63650	
ILLINOIS FED. AID PROJECT				

BY	DATE
SURVEYED	
PLOTTED	
REPLACED	
NO. BOOK	
AREAS CHECKED	

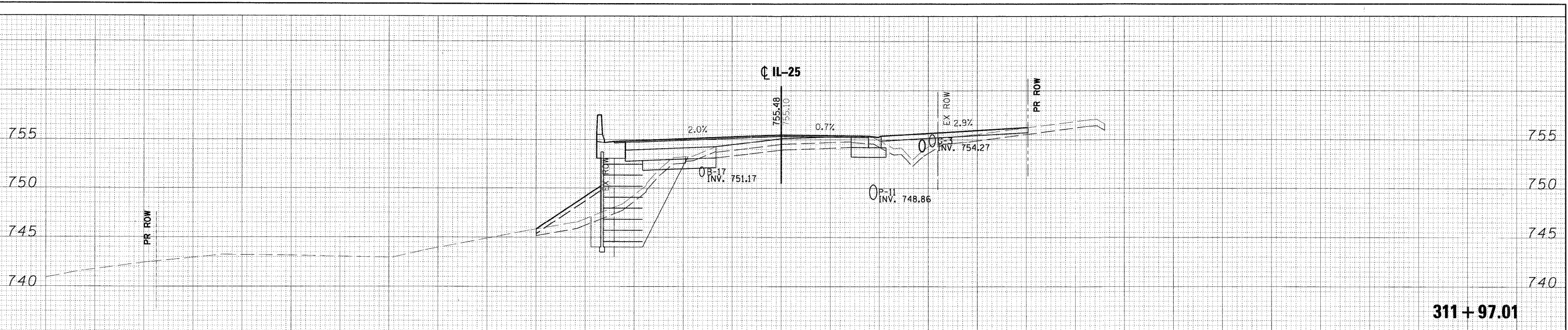

BY	DATE
SURVEYED	
PLOTTED	
REPLACED	
NO. BOOK	
AREAS CHECKED	

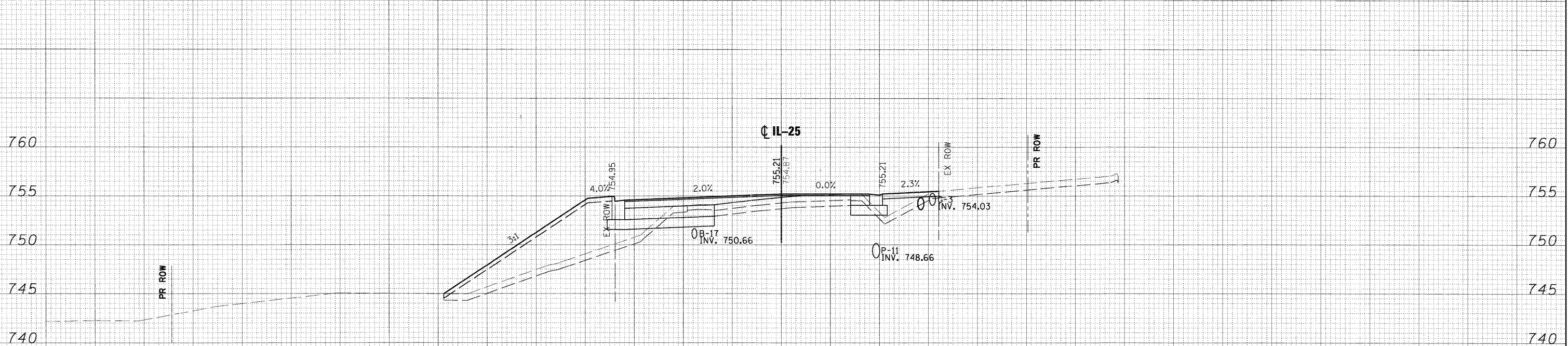

PLOT SCALE: 1/8" = 1'-0"
 FILE NAME: ...cross-sections\IL25-pxs.dgn
 USER NAME: mcoleman
 PLOT DATE: 11/10/2011

DESIGNED - MAC	REVISED -	 CITY OF ST. CHARLES	IL 25 CROSS-SECTIONS		F.A. RTE.	SECTION	COUNTY	TOTAL SHEETS	SHEET NO.
DRAWN - TMB	REVISED -				04-00092-00-BR	KANE	440	402	
CHECKED - RMT	REVISED -		SCALE: SHEET NO. 18 OF 23 SHEETS STA. 311+70.00 TO STA. 311+97.01		CONTRACT NO. 63650		[ILLINOIS] FED. AID PROJECT		
DATE - 10/23/2011	REVISED -								

FINAL SURVEY	SURVEYED	BY	DATE
NOTE BOOK	PLOTTED		
AREAS CHECKED	TEMPLATE		
NO.			

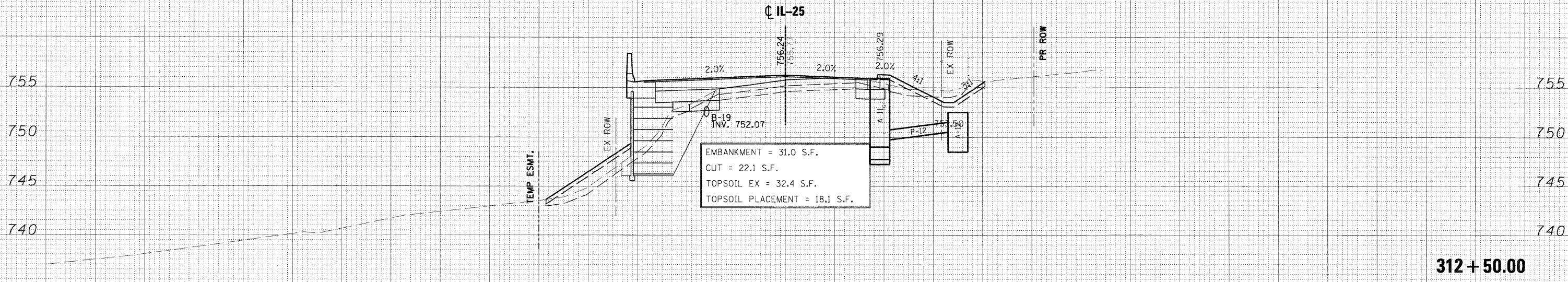

ORIGINAL SURVEY	SURVEYED	BY	DATE
NOTE BOOK	PLOTTED		
AREAS CHECKED	TEMPLATE		
NO.			

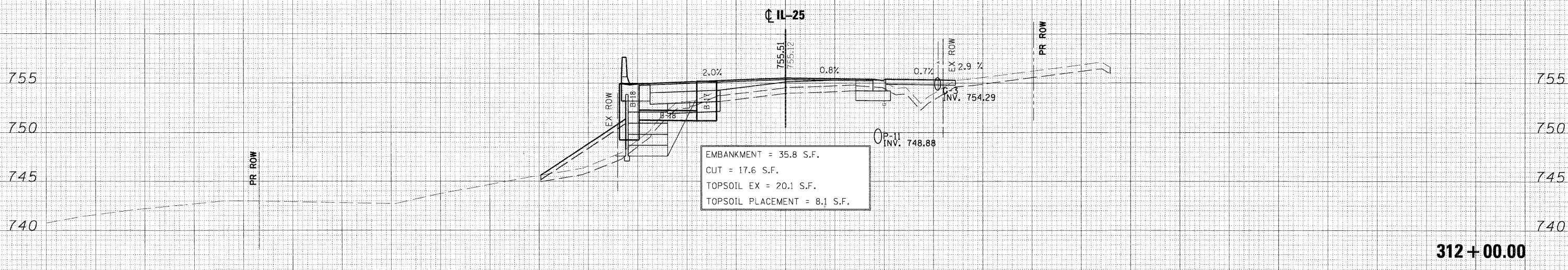

FILE NAME * ...
 USER NAME * mcoleman
 PLOT DATE * 11/22/2011

DESIGNED	-	MAC	REVISED	-
DRAWN	-	TMB	REVISED	-
CHECKED	-	RMT	REVISED	-
DATE	-	10/23/2011	REVISED	-



CITY OF ST. CHARLES

IL 25
CROSS-SECTIONS

SCALE: SHEET NO. 19 OF 23 SHEETS STA. 312+00.00 TO STA. 312+50.00

F.A. RTE.	SECTION	COUNTY	TOTAL SHEETS	SHEET NO.
	04-00092-00-BR	KANE	440	403
			CONTRACT NO. 63650	
ILLINOIS FED. AID PROJECT				

DATE	
BY	
FINAL SURVEY	
PLOTTED	
NOTE BOOK	
AREAS CHECKED	

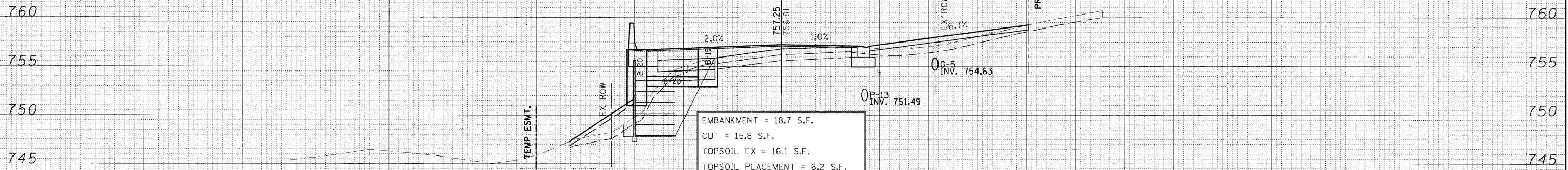

DATE	
BY	
ORIGINAL SURVEY	
PLOTTED	
NOTE BOOK	
AREAS CHECKED	

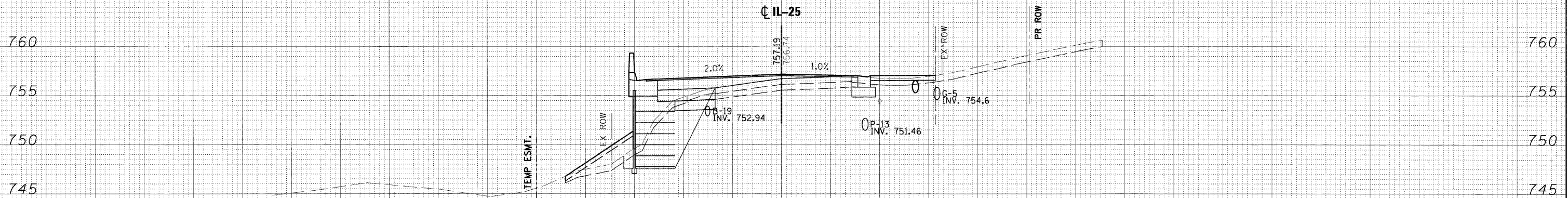

PLOT SCALE: 1/8" = 10'-0"
 FILE NAME: ...cross-sections\IL25-pxs.dgn
 USER NAME: mcoleman
 PLOT DATE: 11/10/2011

FILE NAME =	DESIGNED - MAC	REVISED -	 engineers · scientists · planners	 CITY OF ST. CHARLES	IL 25 CROSS-SECTIONS		F.A. RTE.	SECTION	COUNTY	TOTAL SHEETS	SHEET NO.
...cross-sections\IL25-pxs.dgn	DRAWN - TMB	REVISED -					04-00092-00-BR	KANE	440	404	
USER NAME = mcoleman	CHECKED - RMT	REVISED -					CONTRACT NO. 63650				
PLOT DATE = 11/10/2011	DATE - 10/23/2011	REVISED -					ILLINOIS FED. AID PROJECT				
SCALE: SHEET NO. 20 OF 23 SHEETS STA. 312+97.27 TO STA. 313+00.00											

FINAL	SURVEYED	DATE
SURVEY	PLOTTED	BY
NOTE BOOK	TEMPLATE	
AREAS CHECKED		
NO.		

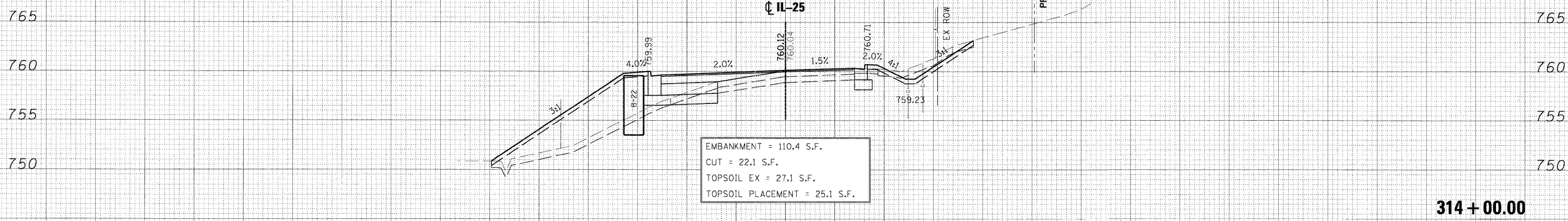

314 + 00.00

ORIGINAL	SURVEYED	DATE
SURVEY	PLOTTED	BY
NOTE BOOK	TEMPLATE	
AREAS CHECKED		
NO.		

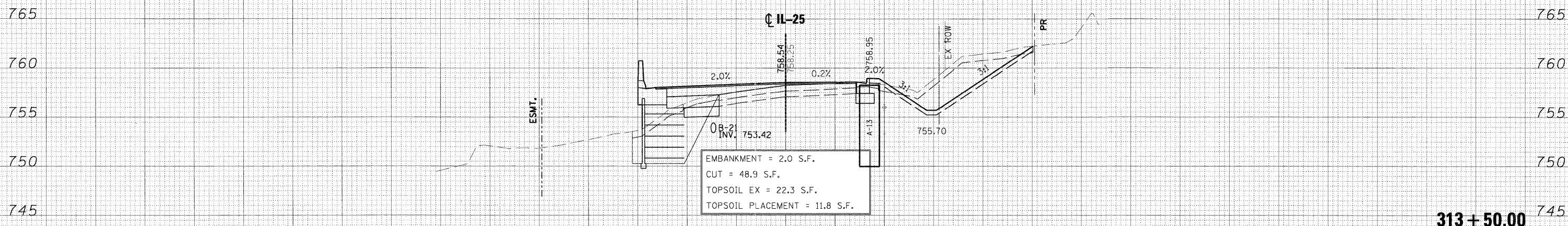

313 + 50.00

DATE	BY
SURVEYED	PLOTTED
NOTE BOOK	TEMP. DATE
NO.	AREAS CHECKED

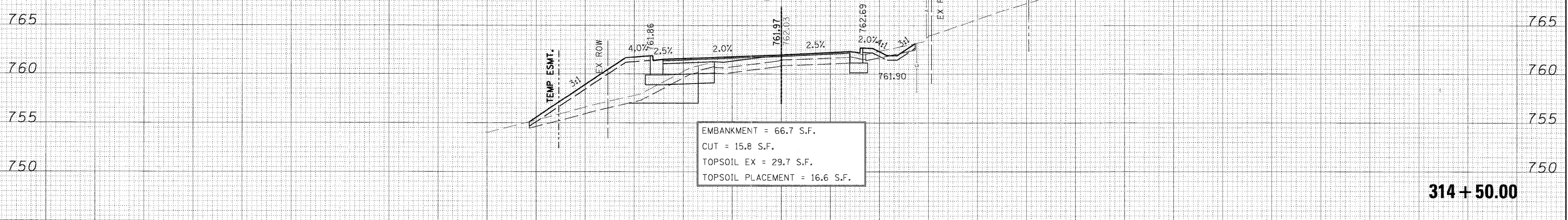

314 + 50.00

DATE	BY
SURVEYED	PLOTTED
NOTE BOOK	TEMP. DATE
NO.	AREAS CHECKED

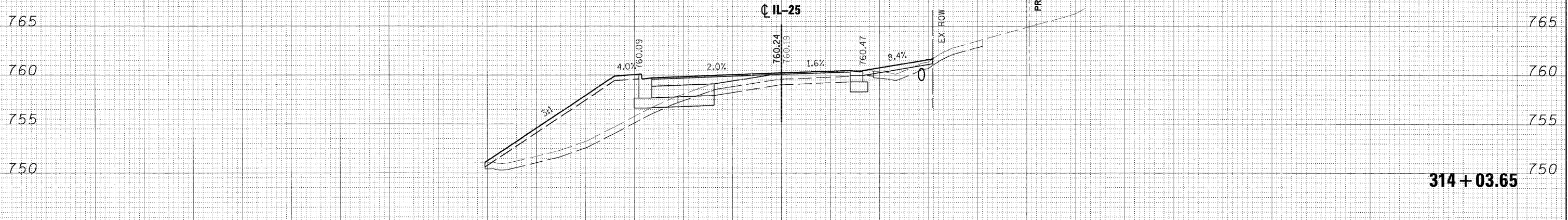

314 + 03.65

PLT SCALE: 1/8" = 1'-0"
 PLOT DATE: 11/10/2011

FILE NAME =	DESIGNED - MAC	REVISED -
...cross_sections\IL25-pxs.dgn	DRAWN - TMB	REVISED -
USER NAME = moeleman	CHECKED - RMT	REVISED -
PLOT DATE = 11/10/2011	DATE - 10/23/2011	REVISED -



CITY OF ST. CHARLES

**IL 25
CROSS-SECTIONS**

SCALE: SHEET NO. 22 OF 23 SHEETS STA. 314+03.65 TO STA. 314+50.00

F.A. RTE.	SECTION	COUNTY	TOTAL SHEETS	SHEET NO.
	04-00092-00-BR	KANE	440	406
CONTRACT NO. 63650				
ILLINOIS FED. AID PROJECT				

FINAL SURVEY	SURVEYED	BY	DATE
NOTE BOOK NO.	PLOTTED		
	TEMPLATE		
	AREAS CHECKED		

ORIGINAL SURVEY	SURVEYED	BY	DATE
NOTE BOOK NO.	PLOTTED		
	TEMPLATE		
	AREAS CHECKED		

PLOT SCALE: 1"=10'
 FILE NAME: ...cross-sections\IL25-pxt.dgn
 USER NAME: mcoleman
 PLOT DATE: 11/10/2011

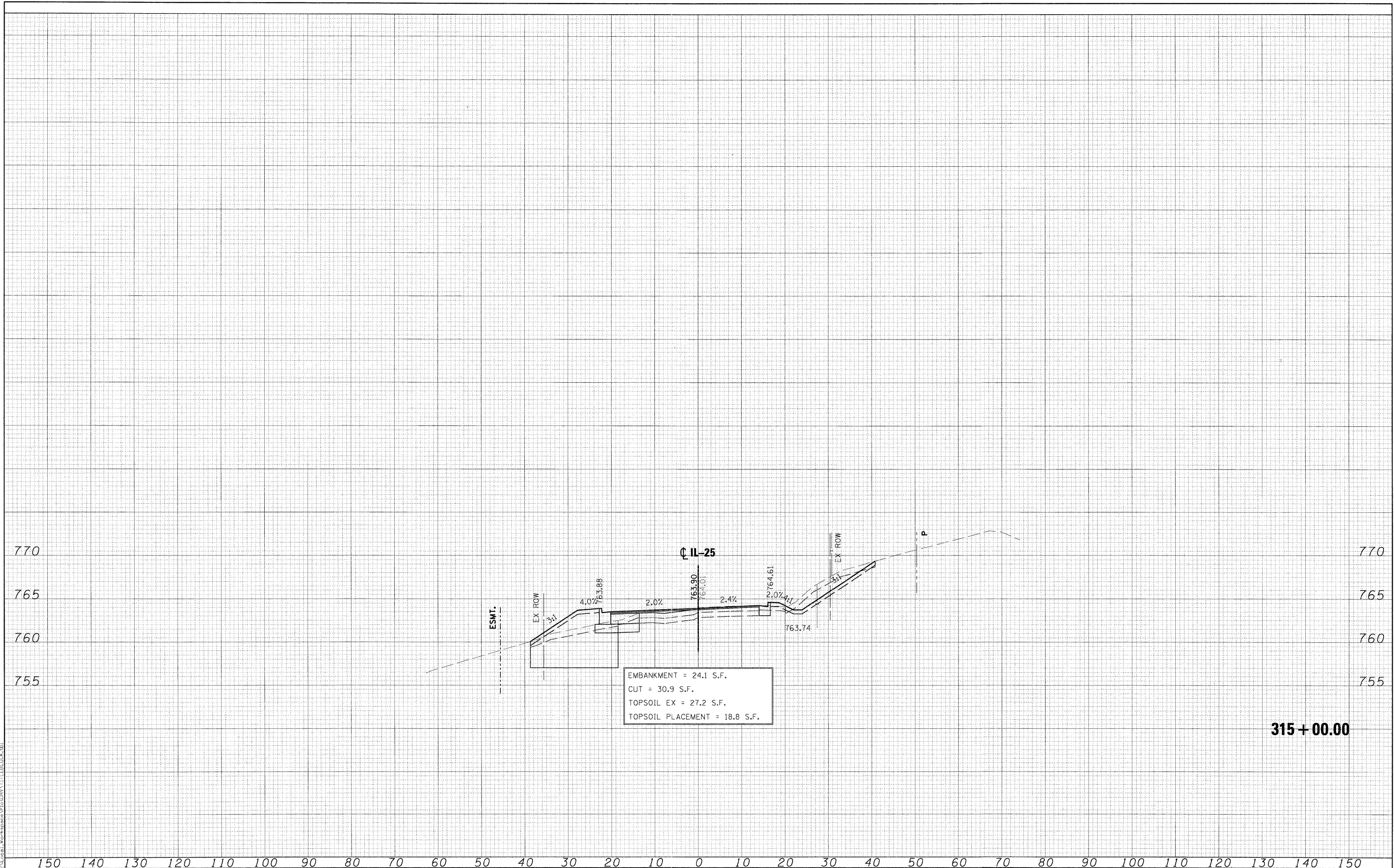

315 + 00.00

DESIGNED - MAC	REVISED -
DRAWN - TMB	REVISED -
CHECKED - RMT	REVISED -
DATE - 10/23/2011	REVISED -



CITY OF ST. CHARLES

**IL 25
CROSS-SECTIONS**

SCALE: SHEET NO. 23 OF 23 SHEETS STA. 315+00.00 TO STA. 315+00.00

F.A. RTE.	SECTION	COUNTY	TOTAL SHEETS	SHEET NO.
	04-00092-00-BR	KANE	440	407
			CONTRACT NO. 63650	
ILLINOIS FED. AID PROJECT				

DATE _____
 BY _____
 SURVEYED _____
 PLOTTED _____
 NOTE BOOK _____
 NO. _____

DATE _____
 BY _____
 SURVEYED _____
 PLOTTED _____
 NOTE BOOK _____
 NO. _____

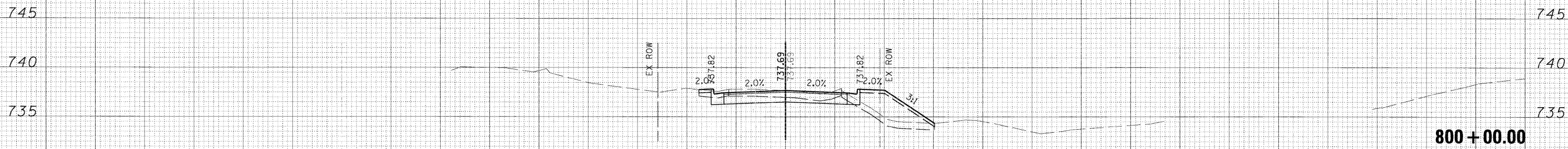

EMBANKMENT = 13.3 S.F.
 CUT = 16.0 S.F.
 TOPSOIL EX = 16.6 S.F.
 TOPSOIL PLACEMENT = 5.9 S.F.

PLOT SCALE: 1/8" = 1'-0"
 FILE NAME: ...Cross_sections\PNLDS-prs.dgn
 USER NAME: moeiman
 PLOT DATE: 11/9/2011

FINAL SURVEY	SURVEYED	BY	DATE
SURVEY	PLOTTED		
NOTE BOOK	TEMPLATE		
NO.	AREAS CHECKED		

ORIGINAL SURVEY	SURVEYED	BY	DATE
SURVEY	PLOTTED		
NOTE BOOK	TEMPLATE		
NO.	AREAS CHECKED		

PLOT SCALE: 1/8" = 1'-0"
 MANAGER: [unclear]
 FILE NAME: ...Cross-sections\PNLDS-pxs.dgn
 USER NAME: mcoleman
 PLOT DATE: 11/9/2011

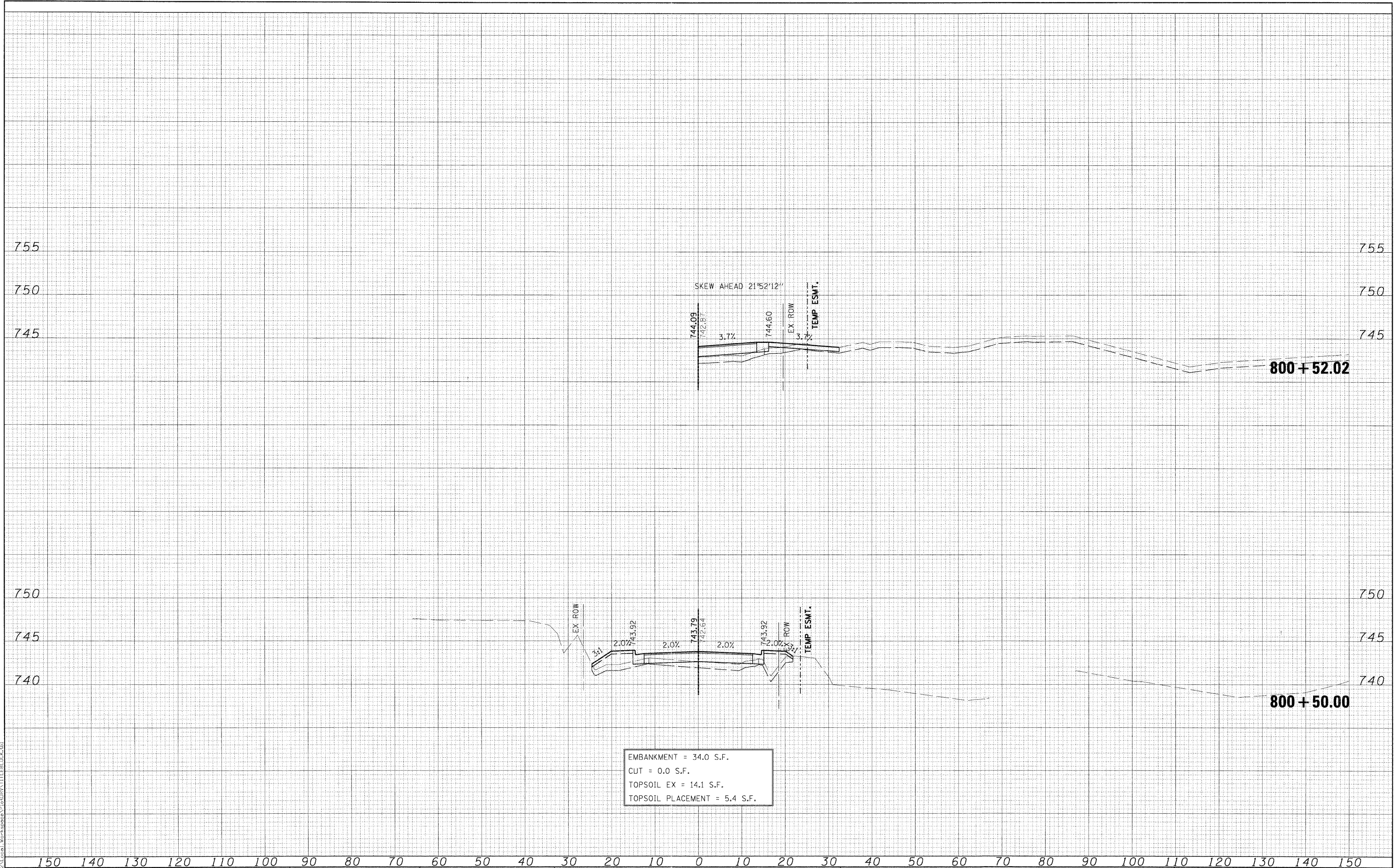

EMBANKMENT = 34.0 S.F.
 CUT = 0.0 S.F.
 TOPSOIL EX = 14.1 S.F.
 TOPSOIL PLACEMENT = 5.4 S.F.

FILE NAME =	DESIGNED - MAC	REVISED -	 CITY OF ST. CHARLES	PINELANDS ROAD CROSS-SECTIONS	F.A. RTE.	SECTION	COUNTY	TOTAL SHEETS	SHEET NO.
...Cross-sections\PNLDS-pxs.dgn	DRAWN - TMB	REVISED -			04-00092-00-BR	KANE	440	409	
USER NAME = mcoleman	CHECKED - RMT	REVISED -			CONTRACT NO. 63650				
PLOT DATE = 11/9/2011	DATE - 10/23/2011	REVISED -			ILLINOIS FED. AID PROJECT				

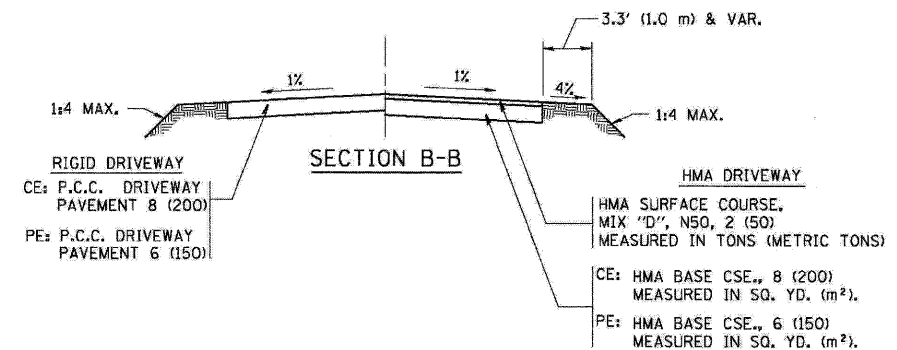
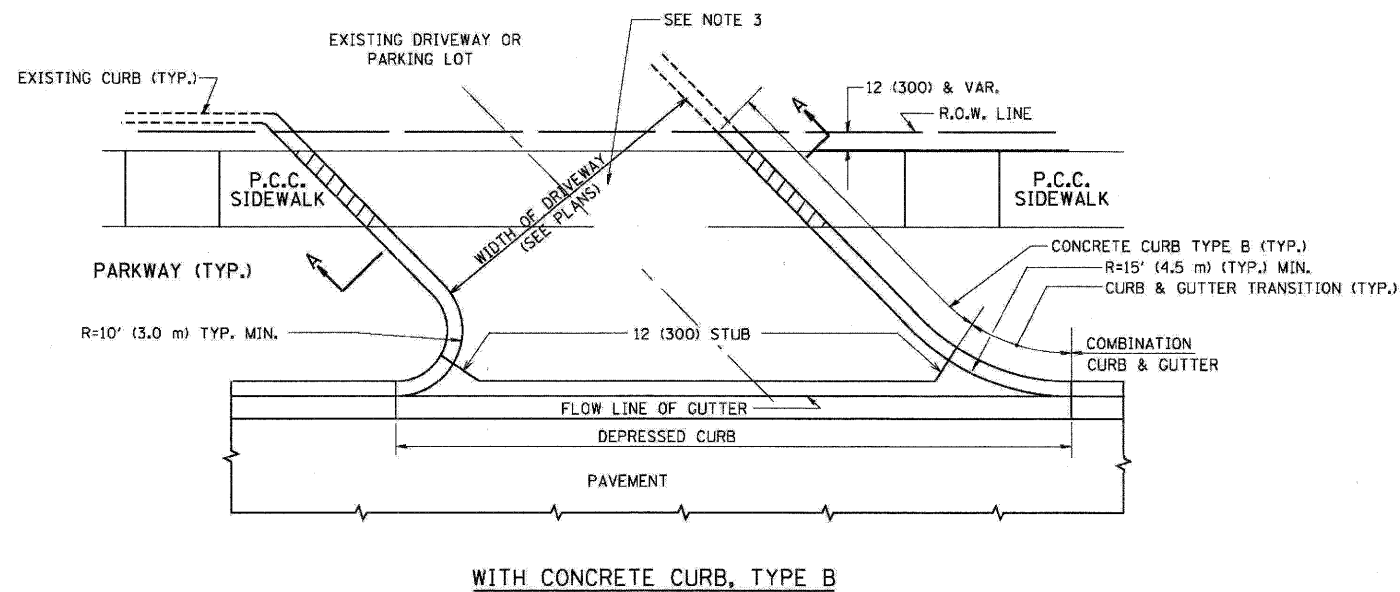
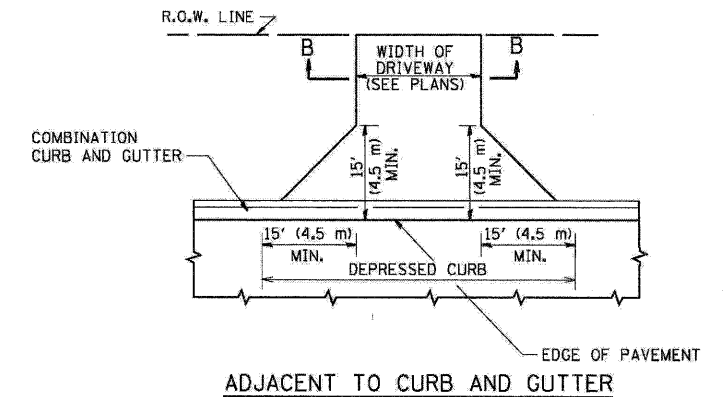
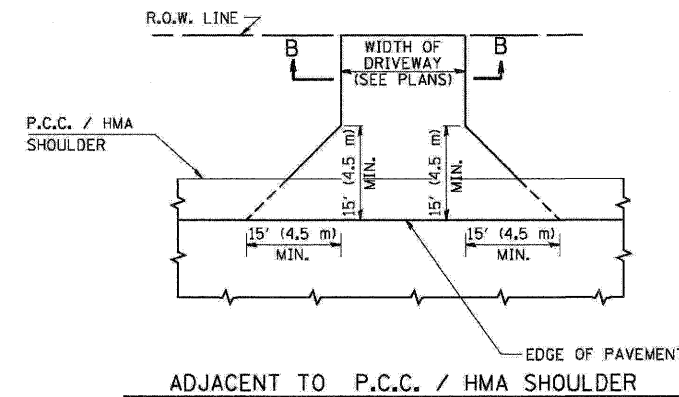
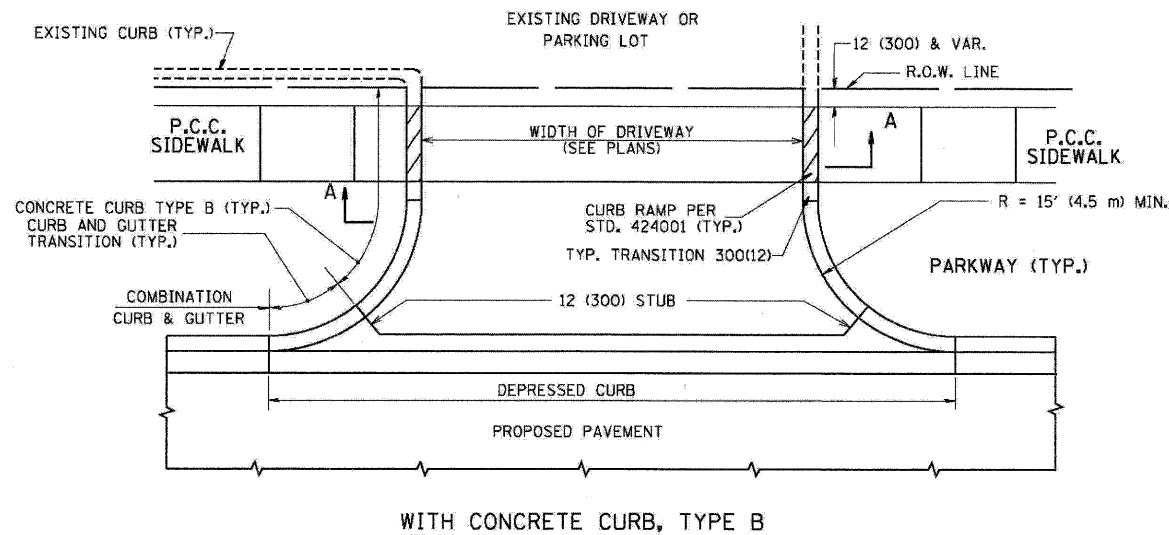

GENERAL NOTES:

DRIVEWAY SLOPES, LOCATIONS, & GEOMETRIC LAYOUT SHALL BE IN ACCORDANCE WITH THE LATEST EDITION OF THE "HANDBOOK FOR POLICY ON PERMITS FOR ACCESS DRIVEWAYS TO STATE HIGHWAYS". FOR FURTHER LAYOUT REQUIREMENTS, REFER TO ILLUSTRATIONS IN THE PERMIT HANDBOOK. DRIVEWAYS SHALL BE REPLACED IN KIND, UNLESS OTHERWISE NOTED ON THE PLANS.

COMMERCIAL DRIVEWAYS SHALL BE CONSTRUCTED WITH CONCRETE CURB, TYPE B RETURNS EXCEPT WHEN THE SIDEWALK EDGE IS 4 FEET (1.2 METERS) OR LESS FROM THE BACK OF CURB, CONSTRUCT A FLARE DRIVEWAY WITHOUT CURB.

THE RESIDENT ENGINEER SHALL CONTACT THE TRAFFIC PERMIT OFFICE AT 847/ 705-4131 FOR ANY QUESTIONS ON DRIVEWAYS SHOWN IN THE PLANS; SPECIFICALLY IN REFERENCE TO ADDITIONAL AND/OR RELOCATION/REMOVAL OF A DRIVEWAY.

COMBINATION CONCRETE CURB & GUTTER SHALL BE MEASURED STRAIGHT ACROSS THE DRIVEWAY. NO ADDITIONAL COMPENSATION WILL BE ALLOWED FOR THE CURB & GUTTER TRANSITION.

1 (25) PREFORMED EXPANSION JOINT FILLER WILL NOT BE PAID SEPARATELY, BUT SHALL BE CONSIDERED INCLUDED IN THE COST OF THE P.C.C. DRIVEWAY PAVEMENT OR P.C.C. SIDEWALK.

WHEN THE P.C.C. SIDEWALK EXTENDS THROUGH THE DRIVEWAY, THE THICKNESS OF THE SIDEWALK IN THE DRIVEWAY AREA SHALL BE THE SAME AS THE DRIVEWAY THICKNESS. SIDEWALK WILL BE PAID FOR AS P.C.C. SIDEWALK OF THE THICKNESS SPECIFIED. SIDEWALK CROSS SLOPE THRU DRIVEWAY AREA TO BE A MAXIMUM OF 1:50.

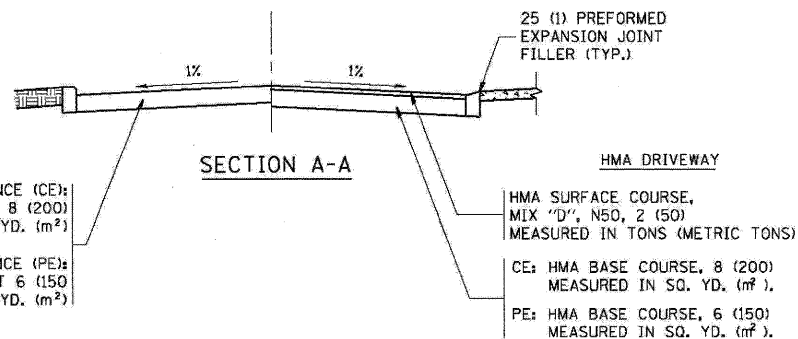

FILE NAME =	USER NAME = ljayse	DESIGNED - R. SHAH	REVISED - P. LoFLUER 04-15-03	STATE OF ILLINOIS DEPARTMENT OF TRANSPORTATION	DRIVEWAY DETAILS - DISTANCE BETWEEN R.O.W. AND FACE OF CURB & EDGE OF SHOULDER >= 15' (4.5 m)		F.A. RTE.	SECTION	COUNTY	TOTAL SHEETS	SHEET NO.	
ct\pwork\pindot\ljayse\0108315\bd01.dwg		DRAWN -	REVISED - R. BORO 01-01-07		SCALE: NONE	SHEET NO. 1 OF 1 SHEETS	STA.	TO STA.	04-00092-00-BR	KANE	440	411
	PLOT SCALE = 50.00000' / in.	CHECKED -	REVISED - R. BORO 06-11-08						BD0156-07 (BD-01)			
	PLOT DATE = 9/6/2011	DATE - 11-04-95	REVISED - R. BORO 09-06-11									CONTRACT NO. 63650
								FED. ROAD DIST. NO. 1 (ILLINOIS) FED. AID PROJECT				

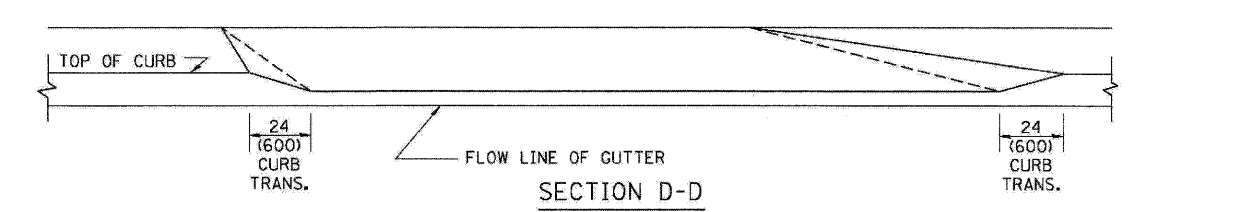
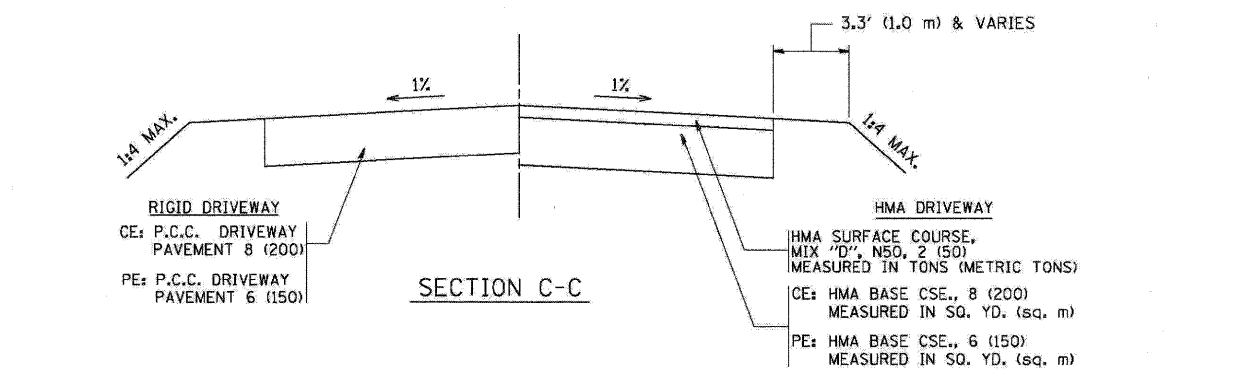
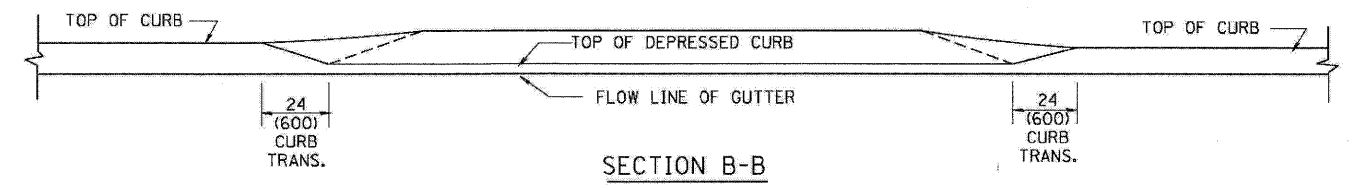
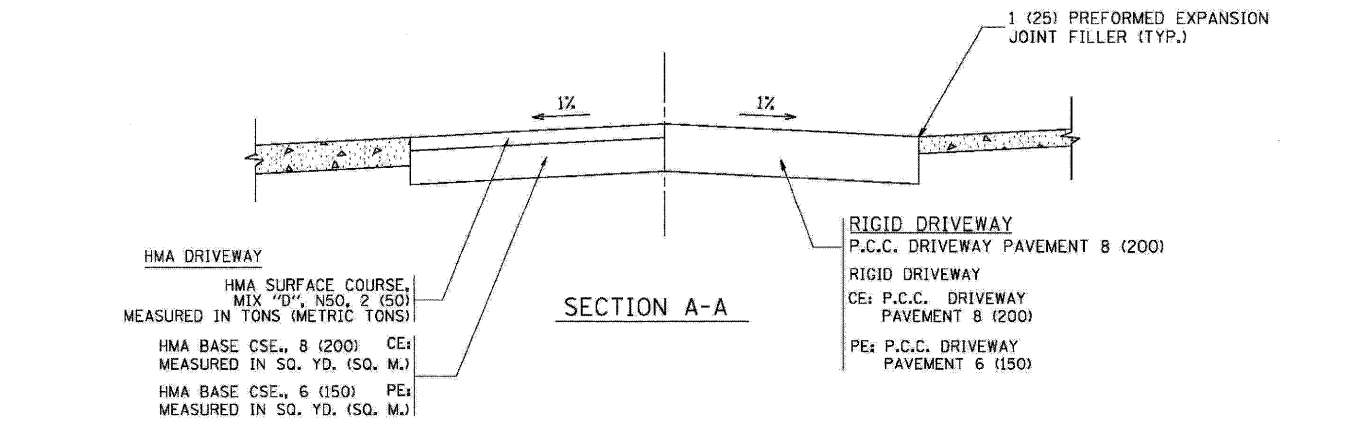
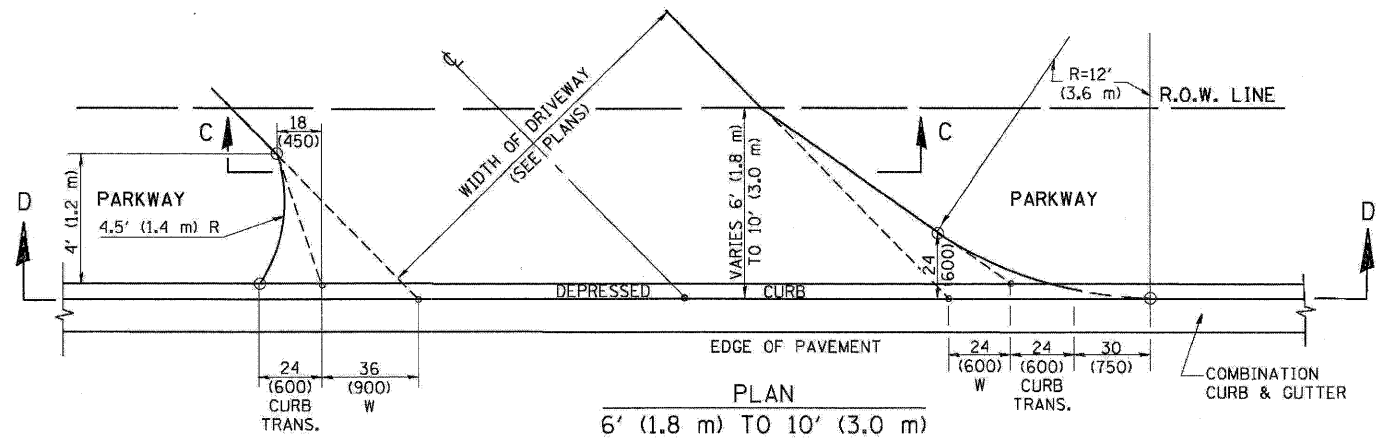
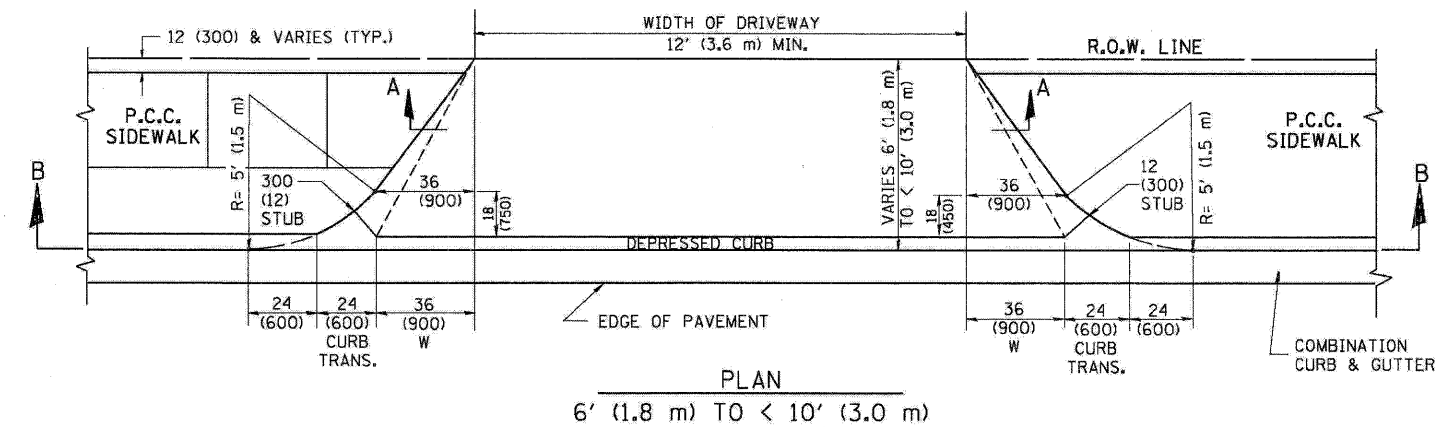
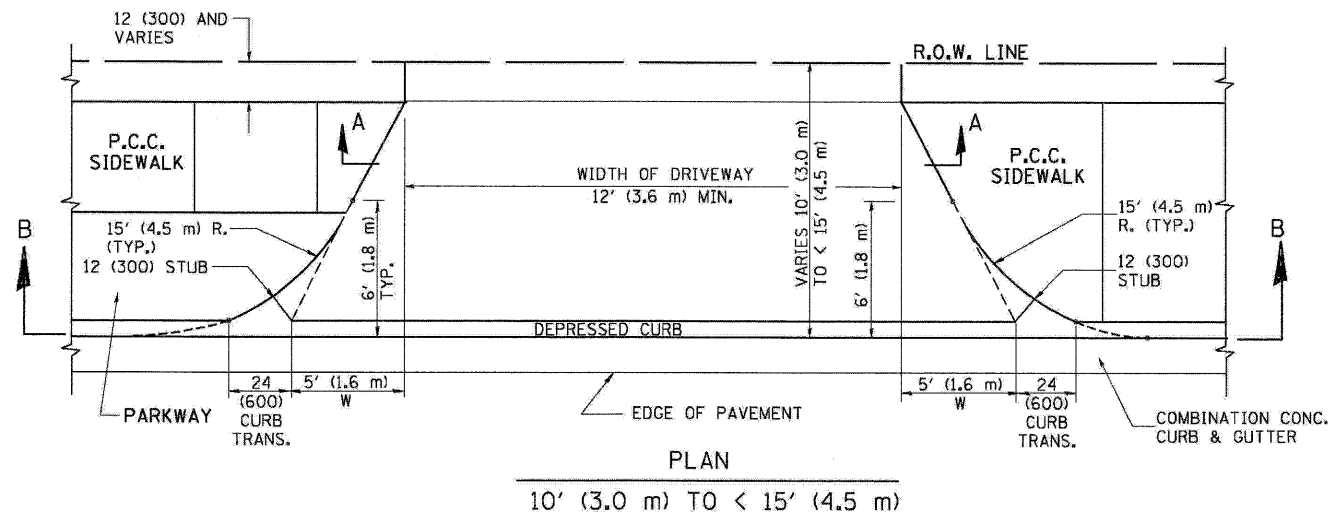

GENERAL NOTES

DRIVEWAY SLOPES, LOCATIONS, & GEOMETRIC LAYOUT SHALL BE IN ACCORDANCE WITH THE LATEST EDITION OF THE "HANDBOOK FOR POLICY ON PERMITS FOR ACCESS DRIVEWAYS TO STATE HIGHWAYS". FOR FURTHER LAYOUT REQUIREMENTS, REFER TO ILLUSTRATION 10 IN THE PERMIT HANDBOOK. WHERE SIDEWALKS EXIST, DRIVEWAYS SHALL BE REPLACED WITH RIGID PAVEMENT. WHERE NO SIDEWALKS EXIST, DRIVEWAYS SHALL BE REPLACED IN KIND. SIDEWALK CROSS SLOPE THRU DRIVEWAY AREA TO BE A MAXIMUM OF 1:50.

WHEN THE DISTANCE BETWEEN R.O.W. AND THE BACK OF CURB IS EQUAL TO OR LESS THAN 8' (2.4 m), THE P.C.C. SIDEWALK SHALL EXTEND TO THE BACK OF CURB.

THE RESIDENT ENGINEER SHALL CONTACT THE TRAFFIC PERMIT OFFICE AT 847/705-4131 FOR ANY QUESTIONS ON DRIVEWAYS SHOWN IN THE PLANS; SPECIFICALLY IN REFERENCE TO ADDITIONAL AND/OR RELOCATION/REMOVAL OF A DRIVEWAY.

COMBINATION CONCRETE CURB & GUTTER SHALL BE MEASURED STRAIGHT ACROSS THE DRIVEWAY. NO ADDITIONAL COMPENSATION WILL BE ALLOWED FOR THE CURB & GUTTER TRANSITION.

THE 1 (25) PREFORMED EXPANSION JOINT FILLER WILL NOT BE PAID SEPARATELY, BUT SHALL BE CONSIDERED INCLUDED IN THE COST OF THE P.C.C. DRIVEWAY PAVEMENT OR P.C.C. SIDEWALK.

"W" VARIES FROM 36 (900) TO 5' (1.5 m) PROPORTIONAL TO THE LENGTH (L), FROM 6' (1.8 m) TO 10' (3 m).

ALL DIMENSIONS ARE IN INCHES (MILLIMETERS) UNLESS OTHERWISE NOTED.

FILE NAME =	USER NAME = jeyso	DESIGNED - R. SHAH	REVISED - M. GOMEZ 04-06-01
ca:\pwork\pwork\dot\1eysa\d0108315\bd02.dwg		DRAWN -	REVISED - P. LofLEUR 04-15-03
	PLOT SCALE = 50.0000' / 1" =	CHECKED -	REVISED - R. BORO 01-01-07
	PLOT DATE = 9/6/2011	DATE - 11-06-95	REVISED - R. BORO 01-01-07

**STATE OF ILLINOIS
DEPARTMENT OF TRANSPORTATION**

**DRIVEWAY DETAILS
DISTANCE BETWEEN ROW AND FACE OF CURB < 15' (4.5 m)**

SCALE: NONE SHEET NO. 1 OF 1 SHEETS STA. TO STA.

F.A. RTE.	SECTION	COUNTY	TOTAL SHEETS	SHEET NO.
	04-0092-00-BR	KANE	440	412
BD400-02 (BD-02)			CONTRACT NO. 63650	
FED. ROAD DIST. NO. 1 [ILLINOIS] FED. AID PROJECT				

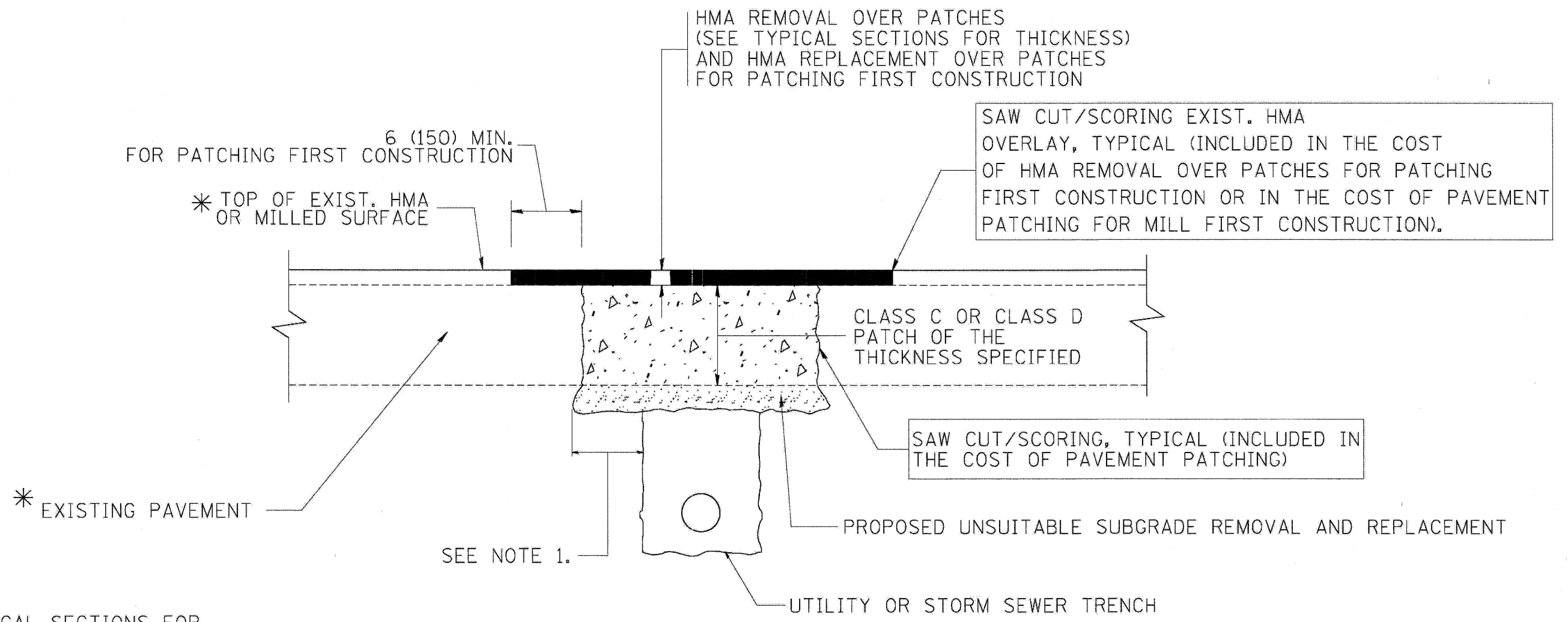

* SEE TYPICAL SECTIONS FOR THICKNESS AND MATERIALS

NOTES:

1. THE WIDTH OF THE FULL DEPTH PATCH OVER A TRENCH SHALL BE 12 (300) WIDER ON EACH SIDE OF THE TRENCH.
2. FOR METHOD OF MEASUREMENT AND BASIS OF PAYMENT, SEE RECURRING SPECIAL PROVISION "PATCHING WITH HOT-MIX ASPHALT OVERLAY REMOVAL".

SEQUENCE OF CONSTRUCTION (PATCHING FIRST)

1. REMOVE THE EXISTING HMA MATERIAL OVER THE AREA TO BE PATCHED.
2. REMOVE AND REPLACE WITH CLASS C OR D PATCH.
3. REPLACE HMA MATERIAL OVER THE AREA TO BE PATCHED.

SEQUENCE OF CONSTRUCTION (MILLING FIRST)

1. MILL HMA FIRST IF THERE IS AT LEAST 4 1/2 INCHES OR MORE OF HMA MATERIAL ON TOP OF THE EXISTING PAVEMENT OR IF THE PAVEMENT IS FULL DEPTH HMA. A MINIMUM OF 2 INCHES OF HMA MATERIAL SHALL BE IN PLACE AFTER MILLING.
2. REMOVE AND REPLACE WITH FULL DEPTH CLASS D PATCHES TO TOP OF MILLED SURFACE.

ALL DIMENSIONS ARE IN INCHES (MILLIMETERS) UNLESS OTHERWISE SHOWN.

FILE NAME = c:\projects\dsts\dst22x34\bd22.dgn	USER NAME = beverdl	DESIGNED - R. SHAH	REVISED - A. ABBAS 04-27-98	STATE OF ILLINOIS DEPARTMENT OF TRANSPORTATION	PAVEMENT PATCHING FOR HMA SURFACED PAVEMENT			F.A. RTE.	SECTION	COUNTY	TOTAL SHEETS	SHEET NO.
	PLOT SCALE = 50.000' / IN.	CHECKED -	REVISED - R. BORO 01-01-07					04-00092-00-BR	KANE	440	413	
PLOT DATE = 10/27/2008	DATE - 10-25-94	REVISED - R. BORO 09-04-07	REVISED - K. ENG 10-27-08		SCALE: NONE	SHEET NO. 1 OF 1 SHEETS	STA. TO STA.	BD400-04 (BD-22)		CONTRACT NO. 63650		
								FED. ROAD DIST. NO. 1 ILLINOIS FED. AID PROJECT				

F.A. RTE.	SECTION	COUNTY	TOTAL SHEETS	SHEET NO.
*	*	KANE	440	414
STA.		TO STA.		
FED. ROAD DIST. NO. 1 ILLINOIS FED. AID PROJECT				
* 04-00092-00-BR				

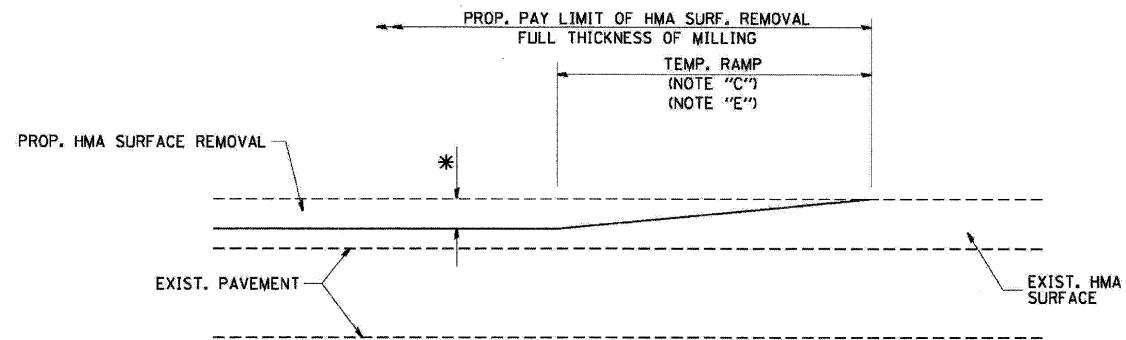

MILLED TEMPORARY RAMP
(FOR BUTT JOINT AND HMA TAPER SEE DETAIL BELOW)

OPTION 1

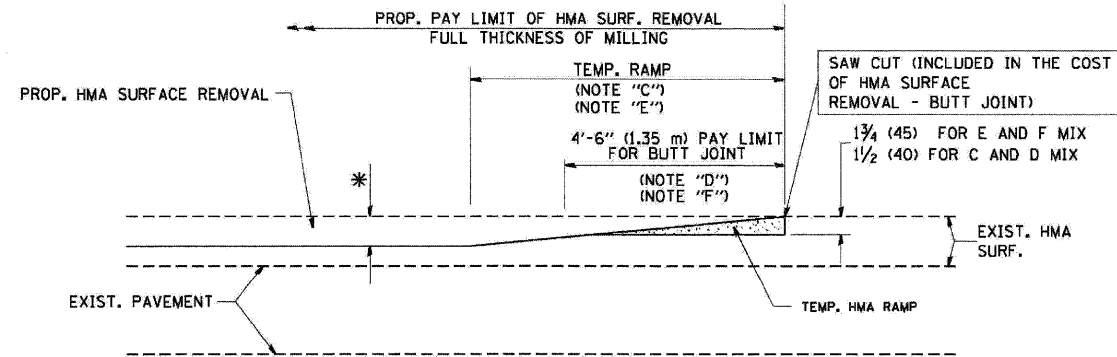

HMA CONSTRUCTED TEMPORARY RAMP
(FOR BUTT JOINT AND HMA TAPER SEE DETAIL BELOW)

OPTION 2
TYPICAL TEMPORARY RAMP

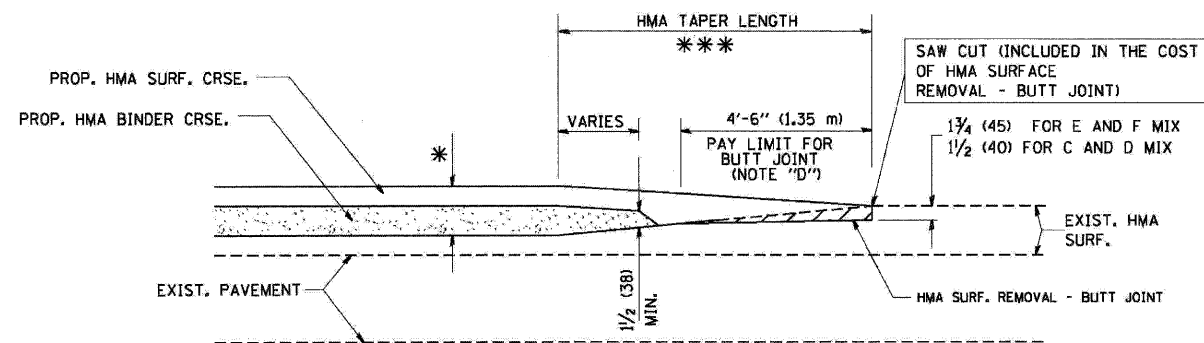

BUTT JOINT AND
HMA TAPER

TYPICAL BUTT JOINT AND HMA TAPER
FOR MILLING AND RESURFACING

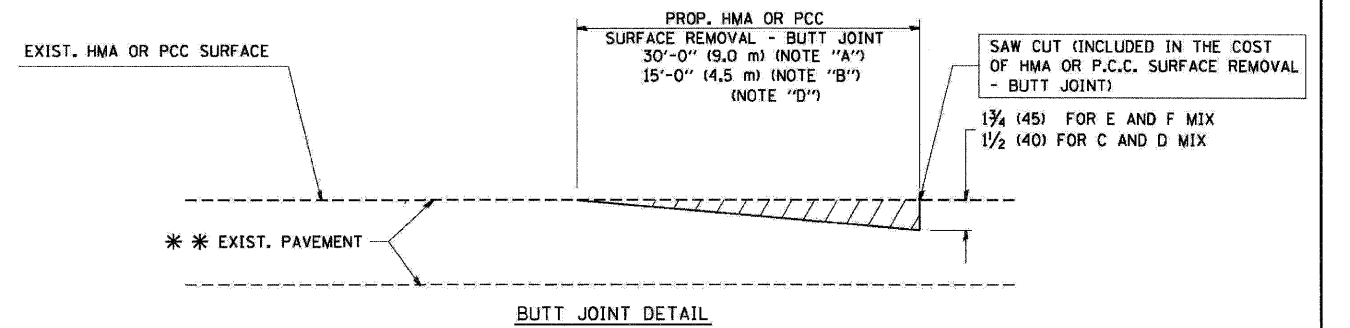

BUTT JOINT DETAIL

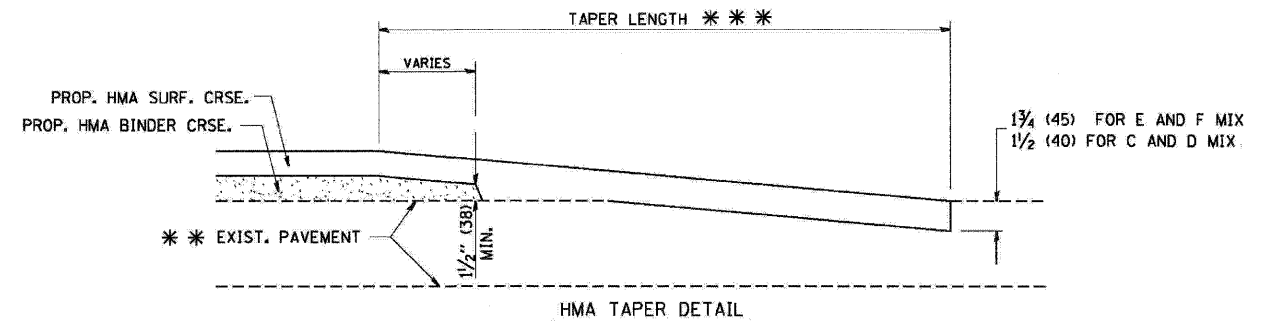

HMA TAPER DETAIL

TYPICAL BUTT JOINT AND HMA TAPER
FOR RESURFACING ONLY

*** PC CONCRETE, HMA OR HMA RESURFACED PAVEMENT.

NOTES

- A: MAINLINE ROADWAYS AND MAJOR SIDE ROADS.
 - B: MINOR SIDE ROADS.
 - C: THE TEMP. RAMP SHALL BE CONSTRUCTED IMMEDIATELY UPON REMOVAL OF THE EXISTING HMA SURFACE.
 - D: THE BUTT JOINT SHALL BE CONSTRUCTED IMMEDIATELY PRIOR TO PLACING THE PROPOSED HMA COURSES.
 - E: TAPER THE TEMP. RAMP AT A RATE OF 3'-0" (900 mm) PER 1 INCH (25 mm) OF MILLING THICKNESS.
 - F: INSTALLATION AND REMOVAL OF THE 4'-6" (1.35 m) TEMP. RAMP IS INCLUDED IN COST OF HMA SURFACE REMOVAL - BUTT JOINT
 - G: SEE ARTICLE 406.08 AND 406.14 OF THE STANDARD SPECIFICATIONS FOR "HMA AND/OR PCC SURFACE REMOVAL, BUTT JOINT".
- * SEE TYPICAL SECTIONS FOR MILLING THICKNESS.
- *** 20'-0" (6.1 m) PER 1 (25) RESURFACING (NOTE "A")
10'-0" (3.0 m) PER 1 (25) RESURFACING (NOTE "B")

ALL DIMENSIONS ARE IN INCHES (MILLIMETERS) UNLESS OTHERWISE SHOWN.

BASIS OF PAYMENT:

THE BUTT JOINT WILL BE PAID FOR AT THE CONTRACT UNIT PRICE PER SQUARE YARD (SQUARE METER) FOR "HOT-MIX ASPHALT SURFACE REMOVAL - BUTT JOINT" OR FOR "PORTLAND CEMENT CONCRETE SURFACE REMOVAL - BUTT JOINT".

REVISIONS	
NAME	DATE
M. DE YONG	6-13-90
M. DE YONG	7-3-90
M. DE YONG	3-27-92
R. SHAH	09/09/94
R. SHAH	10/25/94
A. ABBAS	03/21/97
M. GOMEZ	04/06/01
R. BORO	01/01/07

ILLINOIS DEPARTMENT OF TRANSPORTATION

BUTT JOINT AND
HMA TAPER
DETAILS

SCALE: VERT. NONE
HORIZ. NONE

DRAWN BY
CHECKED BY

BD400-05 (VI-BD32)

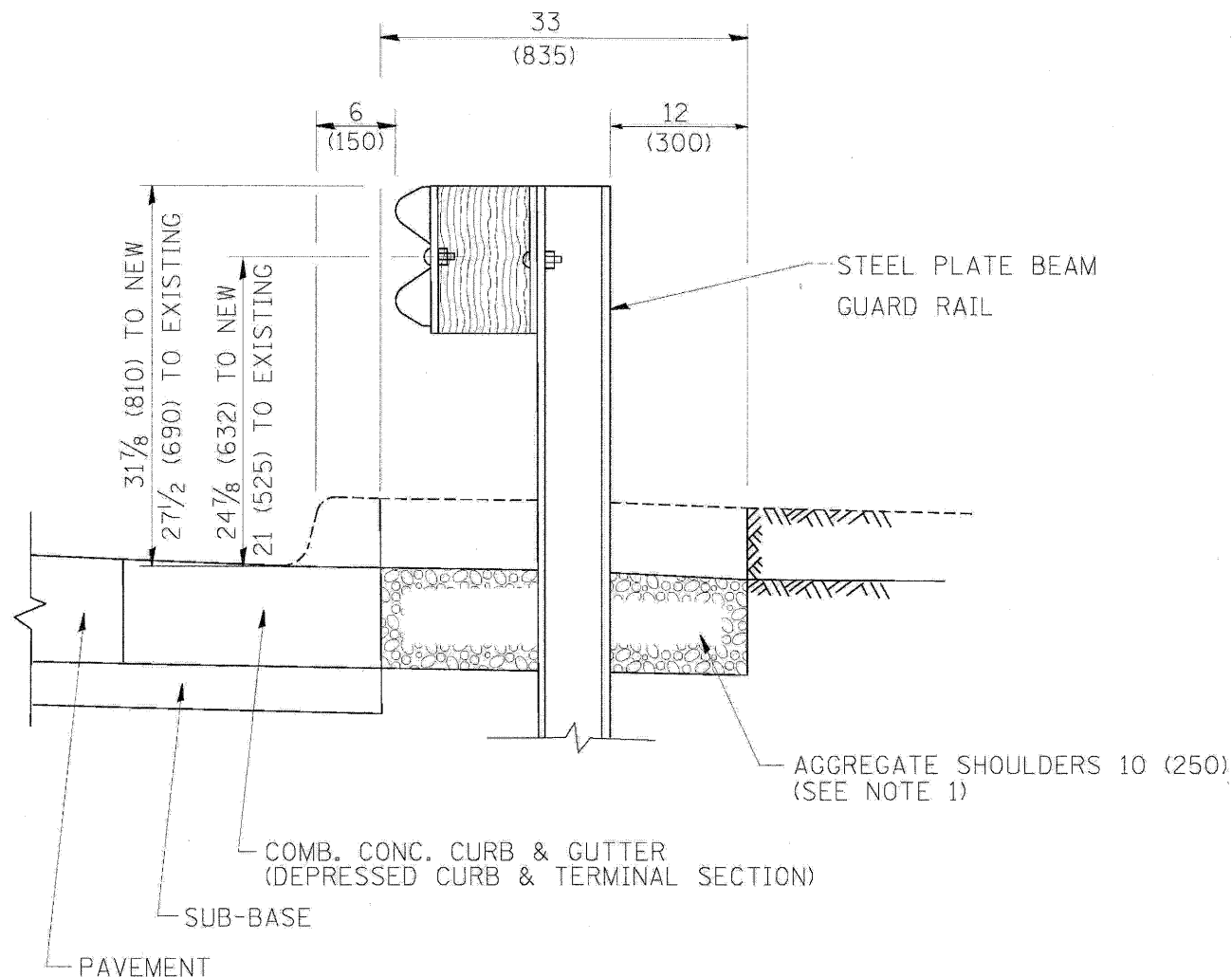

SECTION A-A

- NOTES: 1. THE AGGREGATE SHOULDER, 10" OR HMA SHOULDER, 6" (IF REQUIRED) SHALL EXTEND UNDER THE TRAFFIC BARRIER TERMINAL.
2. "EXISTING" GUARDRAIL REFERS TO CONNECTING TERMINAL SECTION TO GUARD RAILING PRIOR TO THE MIDWEST GUARDRAIL SYSTEM.
3. THE CONTRACTOR SHALL VERIFY THE TYPE/HEIGHT OF GUARDRAIL IN-PLACE BEFORE ORDERING THE NEW TERMINAL SECTION. COST INCLUDED WITH THE COST OF THE TERMINAL. THE TERMINAL SECTION HEIGHT TO BE PLACED MUST MATCH THE HEIGHT OF THE IN-PLACE GUARDRAIL.

DETAILS FOR STEEL PLATE BEAM
 GUARD RAIL ADJACENT TO CURB AND GUTTER
 [FOR ROADWAY SPEED 35 MPH (60 kmh) TO 45 MPH (70 kmh)]

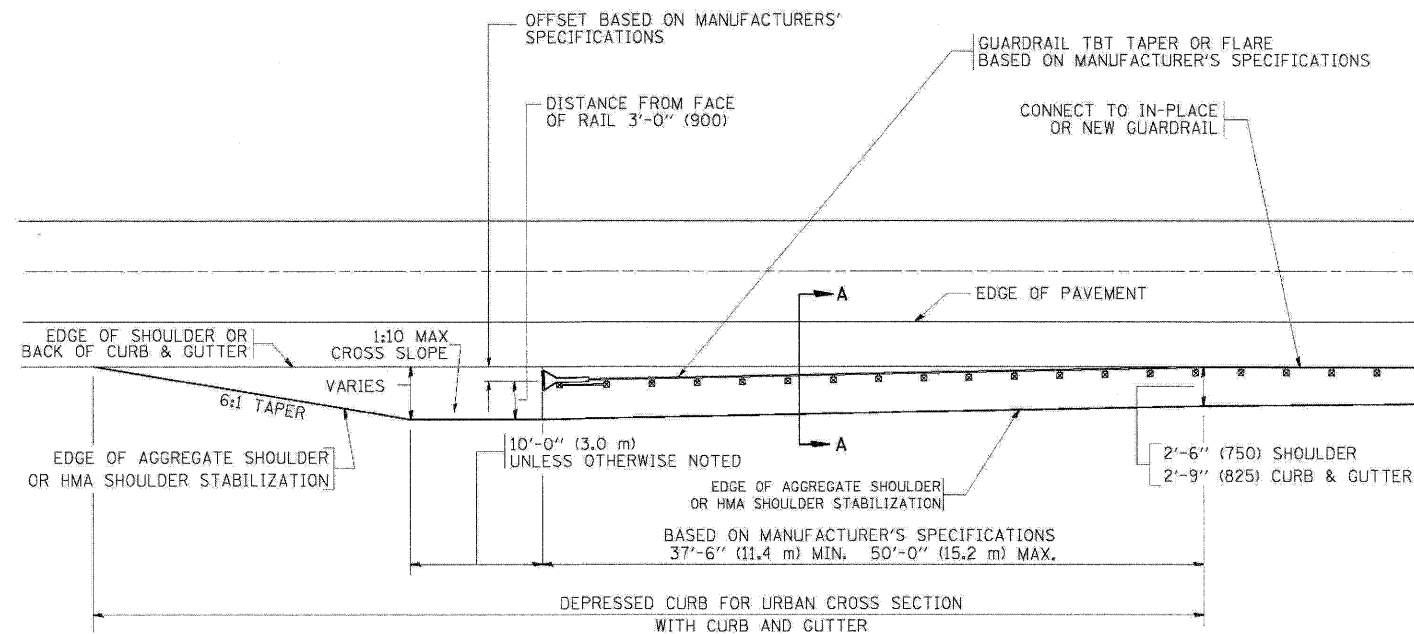

DEPRESSED CURB AND GUTTER AND
 SHOULDER TREATMENT AT TBT TY. 1 SPL.

BASIS OF PAYMENT: HMA SHOULDERS 6 (150) (IF REQUIRED) WILL BE PAID FOR AT THE CONTRACT UNIT PRICE PER SQUARE YARD (SQUARE METER) FOR "HOT-MIX ASPHALT SHOULDERS 6" (150 mm)".

STEEL PLATE BEAM GUARD RAIL AND TRAFFIC BARRIER TERMINAL, OF THE TYPE SPECIFIED WILL BE PAID FOR SEPARATELY.

TBT = TRAFFIC BARRIER TERMINAL
 ALL DIMENSIONS ARE IN INCHES (MILLIMETERS) UNLESS OTHERWISE SHOWN.

FILE NAME =	USER NAME = dmvalkoegn	DESIGNED - M. DE YONG	REVISED - E. GOMEZ 08-28-00
en\pik\work\p\dot\DOT\DOT\4\KUS\5\4\2108315\1\34.dgn		DRAWN -	REVISED - R. BORO 01-01-07
		CHECKED -	REVISED - R. BORO 12-08-2008
		DATE - 09-22-90	REVISED - R. BORO 09-14-2009

STATE OF ILLINOIS
 DEPARTMENT OF TRANSPORTATION

DETAILS FOR DEPRESSED CURB & GUTTER AND
 SHOULDER TREATMENT AT TBT TY 1 SPL.

SCALE: NONE SHEET NO. 1 OF 1 SHEETS STA. TO STA.

F.A. RTE.	SECTION	COUNTY	TOTAL SHEETS	SHEET NO.
	04-00092-00-BR	KANE	440	415
BD600-10 (BD 34)			CONTRACT NO. 63650	
FED. ROAD DIST. NO. 1 ILLINOIS FED. AID PROJECT				

TYPICAL APPLICATION

THE USE OF CROSS STREET PAVEMENT SEPARATION JOINTS FOR SKEWED OR LARGE INTERSECTIONS WHERE JOINTS MAY NOT MATCH

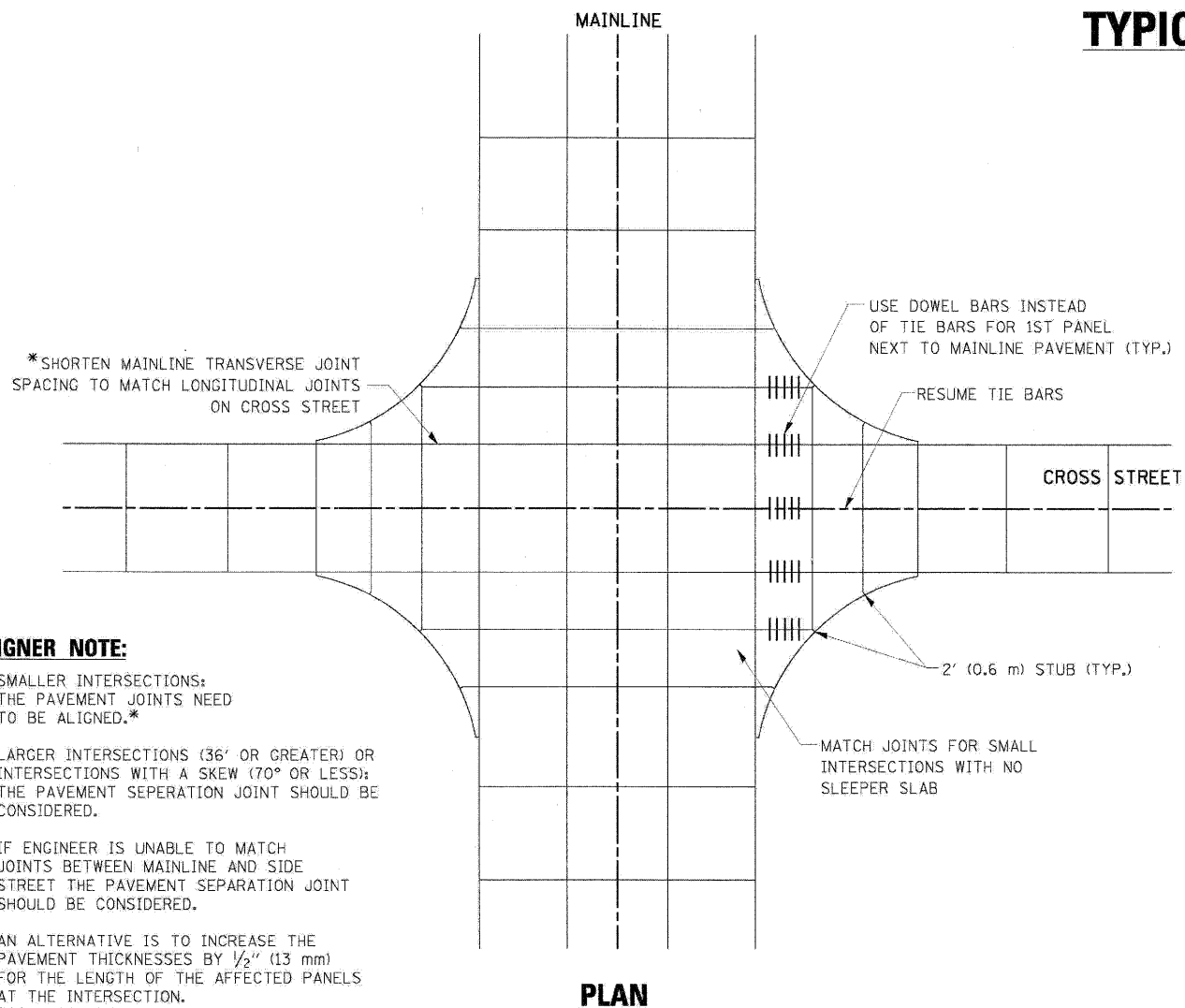

DESIGNER NOTE:

1. SMALLER INTERSECTIONS: THE PAVEMENT JOINTS NEED TO BE ALIGNED.*
2. LARGER INTERSECTIONS (36' OR GREATER) OR INTERSECTIONS WITH A SKEW (70° OR LESS); THE PAVEMENT SEPERATION JOINT SHOULD BE CONSIDERED.
3. IF ENGINEER IS UNABLE TO MATCH JOINTS BETWEEN MAINLINE AND SIDE STREET THE PAVEMENT SEPARATION JOINT SHOULD BE CONSIDERED.
4. AN ALTERNATIVE IS TO INCREASE THE PAVEMENT THICKNESSES BY 1/2" (13 mm) FOR THE LENGTH OF THE AFFECTED PANELS AT THE INTERSECTION.
5. OR MORE) WHERE JOINTS CAN BE MATCHED, USE #8 (25) DOWEL BARS INSTEAD OF #8 (25) TIE BARS AT EDGE OF MAINLINE PAVEMENT WHEN NO PAVEMENT SEPARATION JOINTS USED.

PLAN

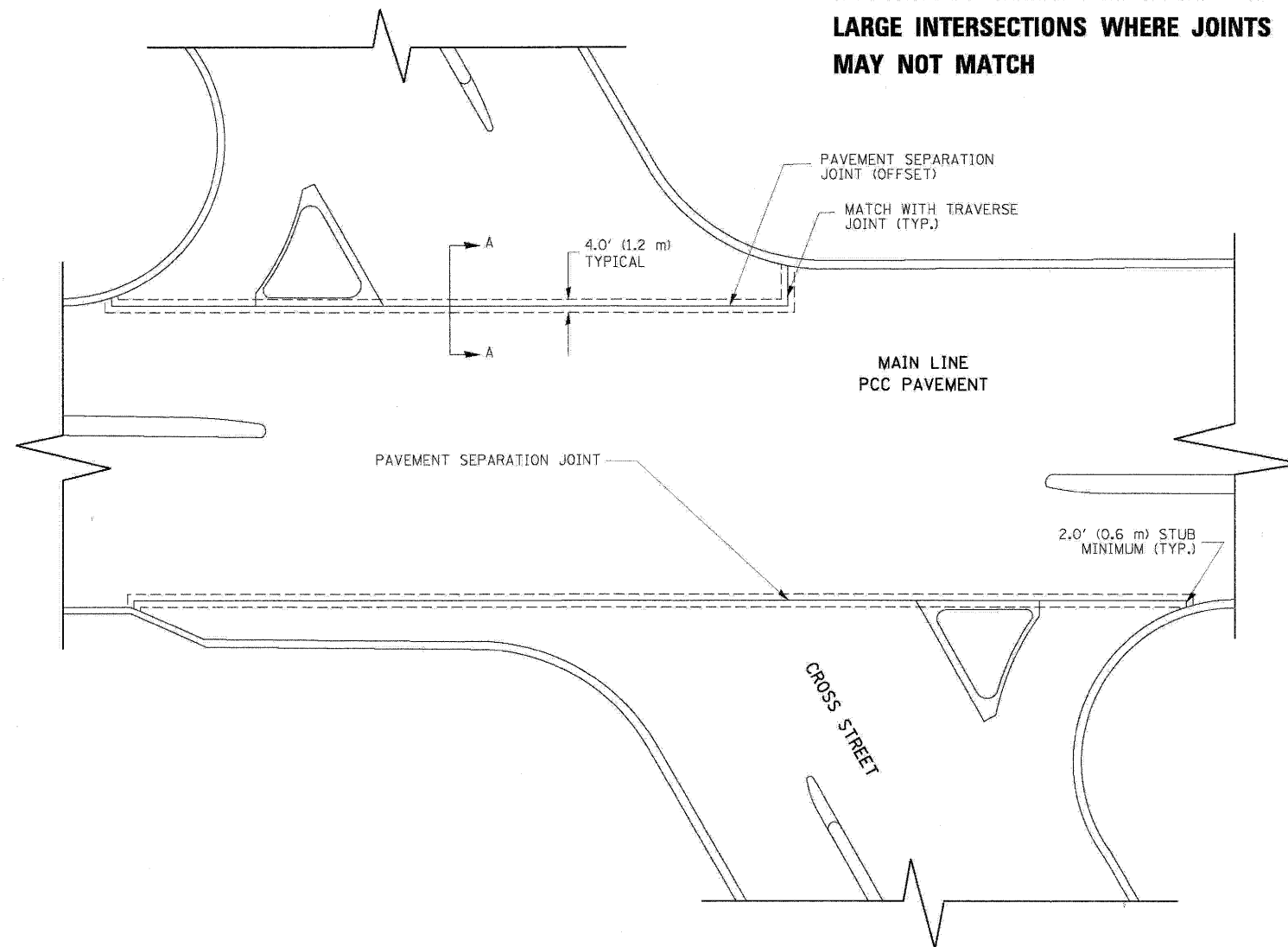

NOTE:

1. JOINT FILLER SHALL CONSIST OF A SHEET OF 1/2" (13 mm) BITUMINOUS PREFORMED FIBER JOINT FILLER CONFORMING TO ARTICLE 1051.03 OF THE STANDARD SPECIFICATIONS.
2. THE JOINT SHALL BE SEALED WITH A HOT POUR JOINT SEALER CONFORMING TO ARTICLE 1050.02 OF THE STANDARD SPECIFICATIONS.
3. A SINGLE LAYER OF FELT ROOFING PAPER SHALL SERVE AS A BOND BREAKER.
4. JOINT SHALL CONTINUE THROUGH COMBINATION CURB & GUTTER OR PCC SHOULDER.
5. PAVEMENT SEPARATION JOINT IS TO BE PAID FOR AS "SLEEPER SLAB" AND IS TO BE MEASURED IN PLACE BY THE LINEAL FOOT.
6. BOND BREAKER AND 1/2" (13 mm) JOINT AND FILLER SHALL BE INCIDENTAL TO THE PAY ITEM "SLEEPER SLAB".

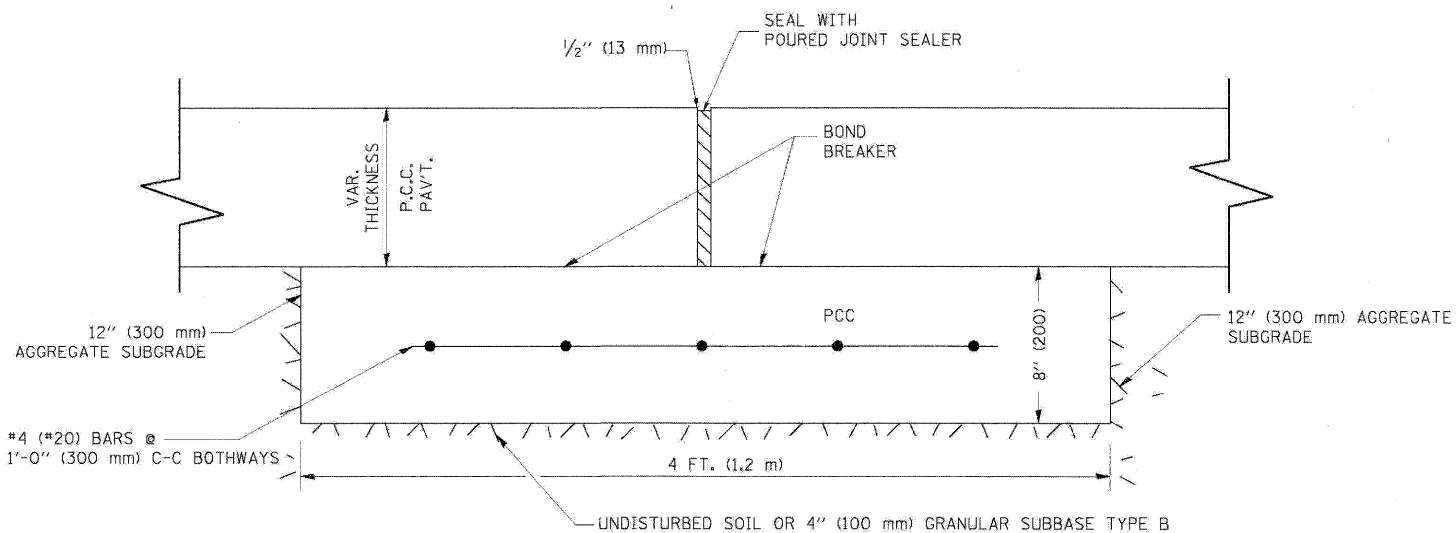

PROPOSED SECTION A-A

FILE NAME = bd52.dgn	USER NAME = legon	DESIGNED =	REVISED = CADD 06-18-10	STATE OF ILLINOIS DEPARTMENT OF TRANSPORTATION	DETAIL OF PAVEMENT SEPARATION JOINT FOR JOINTED PCC PAVEMENTS AT INTERSECTIONS		F.A. RTE.	SECTION	COUNTY	TOTAL SHEETS	SHEET NO.	
		DRAWN =	REVISED =		SCALE: NONE	SHEET NO. 1 OF 1 SHEETS	STA.	TO STA.	04-00092-00-BR	KANE	440	416
		CHECKED =	REVISED =						BD52	CONTRACT NO.	63650	
		DATE = 2/25/2011	REVISED =						ILLINOIS FEB. AID PROJECT			

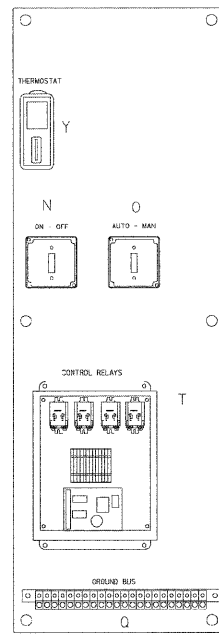

LEFT SIDE PANEL

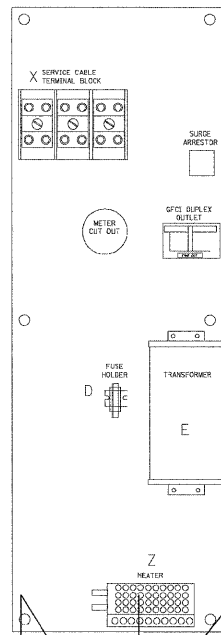
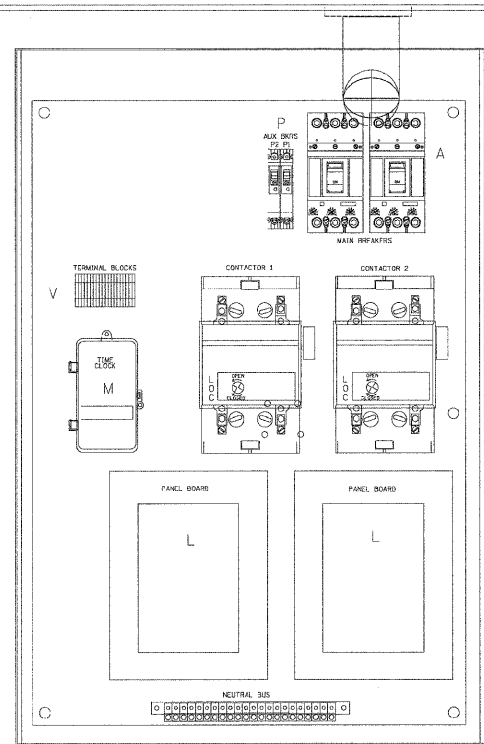

RIGHT SIDE PANEL

BILL OF MATERIALS		
ITEM #	QTY	DESCRIPTION
A	2	FIXED-BITS BREAKERS 2 POLE 175 AMP WITH AUX CONTACT
CLC2	2	MECHANICAL CONTRACTOR R803P7W10E1V3B 2 POLE 200 AMP 240V COIL WITH AUX CONTACTS
D	1	SECTIONAL FUSE HOLDER
E	1	1.5 KVA 277V-240/120 TRANSFORMER
G	1	15 AMP GFCI
H	2	DOOR SWITCH
I	1	LIGHT FIXTURE
J	1	METER FITTING 1 PHASE 3 WIRE 200 AMP
K	1	SURGE ARRESTER
L	2	PANEL BOARD 480/240V 1 PHASE, 250 AMP COPPER BUS
M	1	2 CHANNEL DIGITAL TIME CLOCK
N	1	MOMENTARY SWITCH ON - OF
O	1	DPOI 20 AMP AUTO-MANUAL
P1	1	BREAKER 1P 15A
P2	1	BREAKER 1P 15A
Q	2	COPPER GROUND AND NEUTRAL BUS 1 X 16 X 1/4
T	1	CONTROL RELAY ASSEMBLY 240V COILS WITH DPOI 20 AMP RELAYS (R802C5LR), MOMENTARY CONTACT ADAPTER, QTY 12 TERMINAL BLOCKS
V	20	TERMINAL BLOCKS
X	1	620 AMP SPLICE BLOCK
Y	1	CHROMALOX WR 80, 40-80 DEG THERMOSTAT
Z	1	HEATREX 276-10 375 WATT HEATER

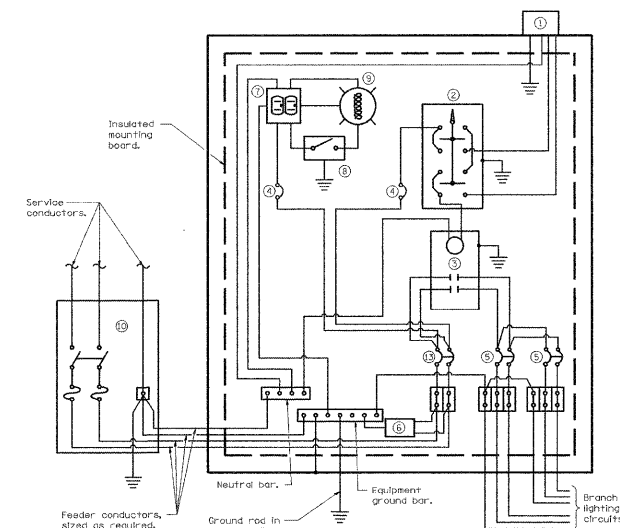

- CONTROL SCHEMATIC**
- ① Photocell with integral surge arrester.
 - ② HAND-OFF-AUTO selector switch.
 - ③ 100 amp, electrically held contactor.
 - ④ 15 amp, 1-pole circuit breaker.
 - ⑤ 20 amp, 2-pole circuit breaker (two spares required but not shown).
 - ⑥ Surge arrester.
 - ⑦ GFCI duplex receptacle.
 - ⑧ Single-pole, single-throw switch.
 - ⑨ Incandescent luminaire, enclosed and gasketed with 100 watt lamp.
 - ⑩ Service disconnect switch - 2-pole, 3-wire, 100 amp, fused at 100 amp, solid neutral in NEMA 4X enclosure having lockable external handle.
 - ⑪ 100 amp, 2-pole circuit breaker.

NOT USE

NOT R A F T

NOTES

- CABINET SHALL BE FABRICATED FROM 0.125-INCH (3.175) SHEET ALUMINUM *3003H14, FORMED AND ARC WELDED ASSEMBLY.
- ALL SCREWS AND HARDWARE SHALL BE PLATED, GALVANIZED, OR MADE OF BRASS, ALUMINUM OR STAINLESS STEEL.
- NAME PLATE SHALL HAVE ENGRAVED 0.75-INCH (19.05) HIGH LETTERS FIELDED IN BLACK, "STATE OF ILLINOIS LIGHTING CONTROLS" UNLESS OTHERWISE SPECIFIED.
- ONE INCH THICK POLYISOCYANURATE INSULATION SHALL BE INSTALLED AND PERMANENTLY CEMENTED ON ALL SIDES OF THE CABINET AND DOORS.
- CABINET SHALL BE PRIMED AND PAINTED AS SPECIFIED.
- ELECTRIC UTILITY METER BOX SHALL BE MOUNTED ON THE SIDE OF CONTROL CABINET AS SHOWN ON THE PANEL LAYOUT DIAGRAM.
- THE COMPLETED CONTROLLER SHALL BE U.L. LISTED AS AN INDUSTRIAL CONTROL PANEL UNDER UL508.
- METAL MOUNTING PANEL SHALL BE #10 GAUGE GALVANIZED SHEET STEEL FLANGED BACK 0.75-INCHES (1.9) ON 4 SIDES.
- CIRCUIT BREAKERS AND CONTACTORS AND OTHER COMPONENTS SHALL BE MOUNTED ON 0.125-INCH (3.175) THICK ELASTIC INSULATION BACK PANEL.
- ALL DEVICES SHALL BE FRONT REMOVABLE.
- TIME CLOCK CHANNEL 1 N.O. CONTACT IS CLOSED NIGHT AND OPEN DAY.
- SET "ON TIME" TO 30 MINUTES AFTER ASTRONOMICAL SUNSET.
- BUS BAR SHALL HAVE 22 LUG TERMINALS SIZED TO ACCOMMODATE REQUIRED WIRE SIZES. NEUTRAL BUS SHALL BE PAINTED WHITE. GROUND BUS SHALL BE PAINTED GREEN.
- ALL LUGS SHALL BE OF COPPER SCREWS AND CONNECTORS, SPRING WELD.
- ALL WIRING TERMINATIONS SHALL BE RATED NOT LESS THAN 75 DEGREE CENTIGRADE.
- ALL CONTROL WIRING SHALL BE 600V MACHINE TOOL WIRE TYPE MTW.
- ALL POWER WIRING SHALL BE 600V TYPE RHW/RHW.
- ALL WIRING WITHIN THE CABINET SHALL BE COLOR CODED AS INDICATED:
R - RED Y - YELLOW
B - BLACK W - WHITE
BL - BLUE G - GREEN
- ALL DIMENSIONS ARE IN MILLIMETERS (INCHES) UNLESS OTHERWISE INDICATED.
- SCHEMATIC SHOWN WITH BREAKER OPEN, CONTACTOR OPEN, CABINET DOOR CLOSED, CLOCK NOT ACTIVE.
- A LAMINATED COPY OF THE CIRCUIT SCHEMATIC AND SCADA I/O DIAGRAM SHALL BE ATTACHED TO THE INSIDE OF THE CONTROLLER.

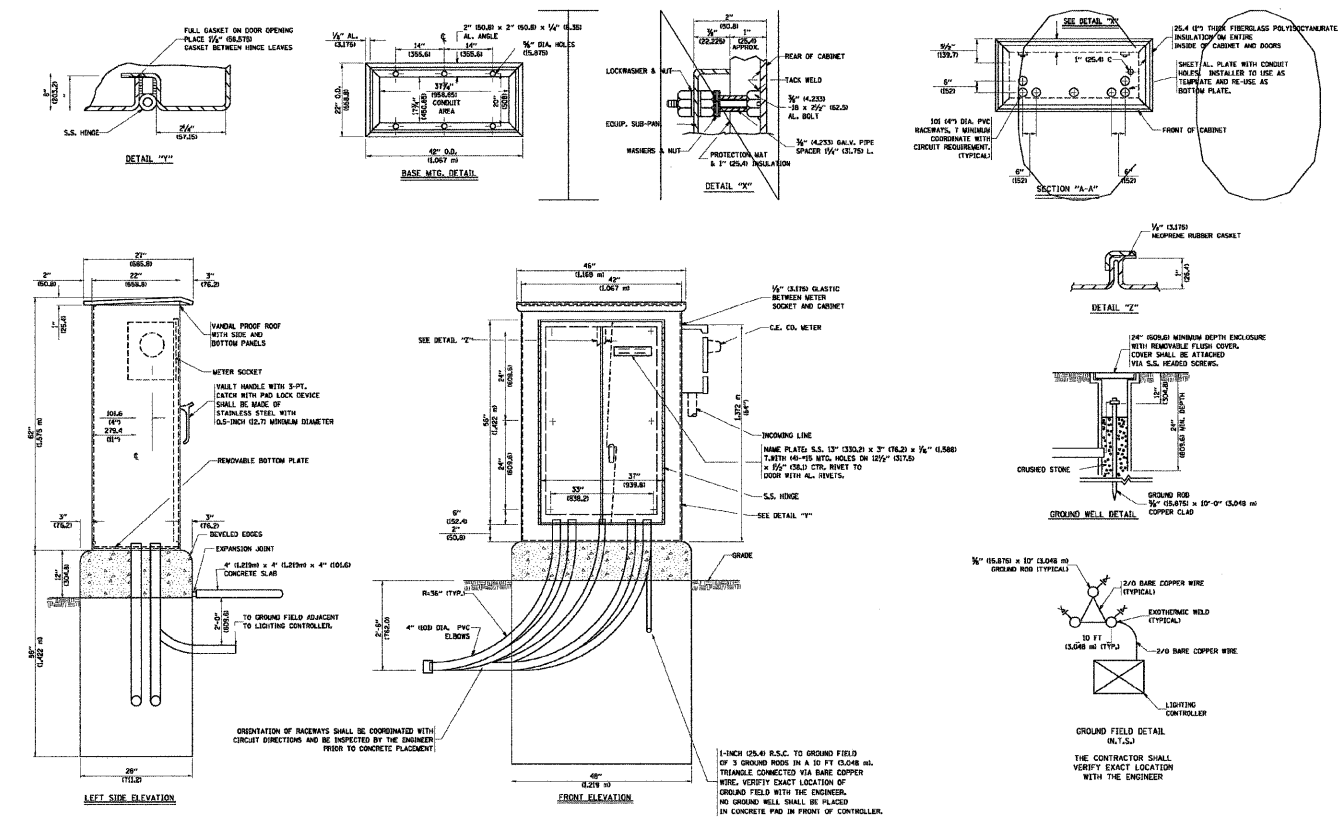

FILE NAME = W:\distatd\22x34\be200.dgn

USER NAME = galianobt
 PLOT SCALE = 50.0000' / IN.
 PLOT DATE = 1/4/2028

DESIGNED -
 DRAWN - CADD
 CHECKED -
 DATE - 12-18-02

REVISED -
 REVISED -
 REVISED -
 REVISED -

STATE OF ILLINOIS
 DEPARTMENT OF TRANSPORTATION

LIGHTING CONTROLLER, DUPLEX TYPE
 SCALE: NONE SHEET NO. 1 OF 4 SHEETS STA. TO STA.

E-200
 F.A. RTE. SECTION COUNTY TOTAL SHEETS SHEET NO.
 04-0092-00-BR KANE 440 417
 E-200 (BE-200) CONTRACT NO. 63650
 FED. ROAD DIST. NO. 1 ILLINOIS FED. AID PROJECT

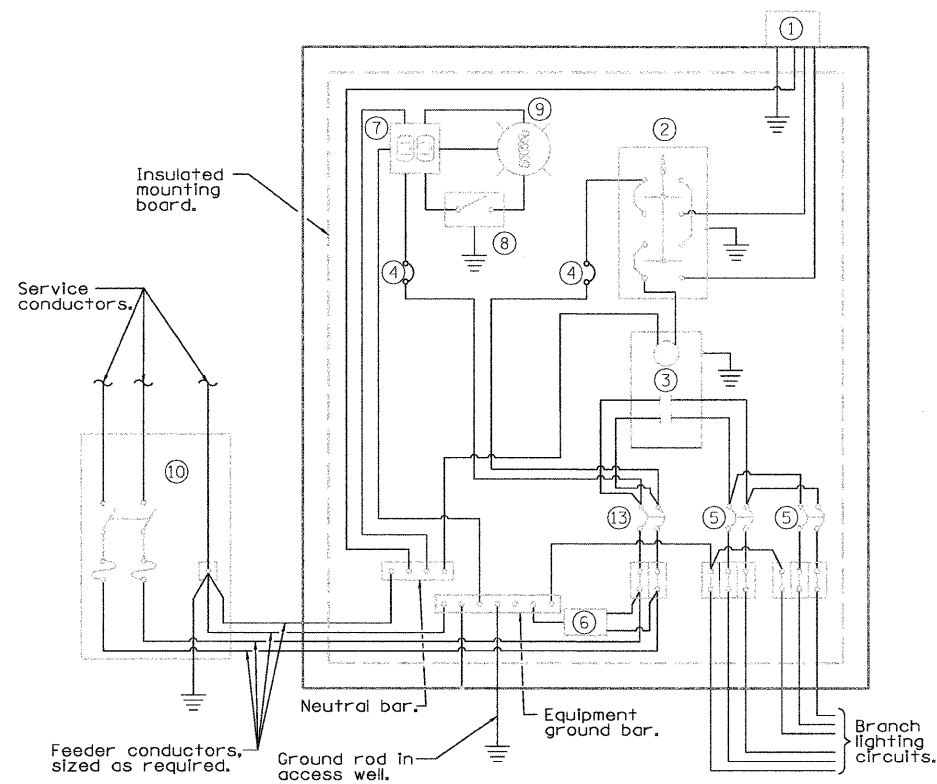

CONTROL SCHEMATIC

- ① Photocell with integral surge arrester.
- ② HAND-OFF-AUTO selector switch.
- ③ 100 amp, electrically held contactor.
- ④ 15 amp, 1-pole circuit breaker.
- ⑤ 20 amp, 2-pole circuit breaker (two spares required but not shown).
- ⑥ Surge arrester.
- ⑦ GFCI duplex receptacle.
- ⑧ Single-pole, single-throw switch.
- ⑨ Incandescent luminaire, enclosed and gasketed with 100 watt lamp.
- ⑩ Service disconnect switch - 2-pole, 3-wire, 100 amp, fused at 100 amp*, solid neutral in NEMA 4X enclosure having lockable external handle.
- ⑬ 100 amp, 2-pole circuit breaker.

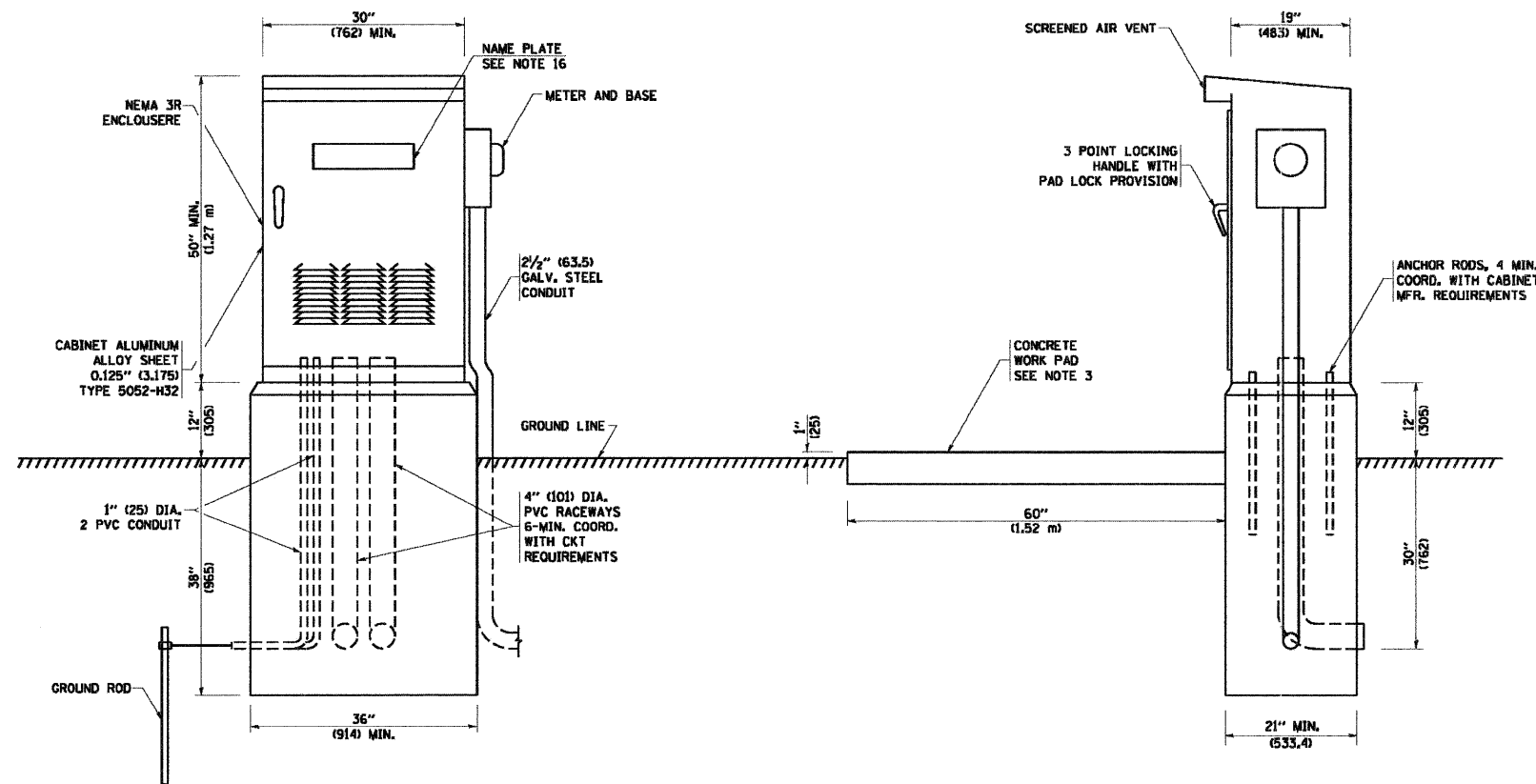

NOTES:

1. ALL DIMENSIONS ARE IN INCHES (MILLIMETERS) UNLESS OTHERWISE SHOWN.
2. FOUNDATION SIZE SHALL BE COORDINATED WITH CABINET SIZE AND MFR.
3. IN FRONT OF CONTROL CABINET DOOR, REMOVE VEGETATION AND 2" (50.8 mm) TOP SOIL. LEVEL THE AREA AND ON TOP, PLACE LENGTH WISE PARALLEL TO CONTROL CABINET, A CONCRETE PAD 36" (914.4 mm) x 60" (1524 mm) x 4" (101 mm) MIN. SIZE. THE COST OF LABOR AND MATERIALS ARE INCLUDED IN THE COST OF THE CONTROLLER.
4. DOOR SHALL BE CONSTRUCTED FROM SAME TYPE OF MATERIAL AND THICKNESS AS CABINET.
5. DOOR SHALL BE EQUIPPED WITH THREE POINT LATCHING MECHANISM WITH NYLON ROLLERS AT TOP AND BOTTOM.
6. DOOR HINGE SHALL BE A HEAVY GAUGE CONTINUOUS HINGE WITH A 1/4" (6.35 mm) DIA. STAINLESS STEEL HINGE PIN.
7. ALL EXTERNAL HARDWARE SHALL BE STAINLESS STEEL.
8. CONTROL WIRING TO BE #12 AWG, 600V, TYPE "SIS" GRAY SWITCH BOARD WIRE, STRANDED COPPER.
9. METER BOX SHALL BE MOUNTED ON THE SIDE OF CONTROL CABINET, NEAR TO THE SERVICE POLE.
10. CABINETS SHALL BE PRIMED AND PAINTED AS SPECIFIED.
11. THE HEADS OF CONNECTORS SCREWS SHALL BE PAINTED WHITE FOR NEUTRAL BAR CONNECTION AND GREEN FOR GROUND BAR CONNECTORS.
12. ALL WIRING WITHIN THE CABINET SHALL BE COLOR CODED AS INDICATED.
R = RED BL = BLUE W = WHITE
B = BLACK Y = YELLOW G = GREEN
13. PROVIDE SEALING GROMMETS FOR ALL OPEN WIRING EXTENDED FROM DEVICES IN BOXES OR CABINETS WITHIN THE CONTROL CABINET.
14. ALL WIRING SHALL BE NEATLY DRESSED AND SUPPORTED.
15. THE CONTROLLER SHALL BE CONSTRUCTED TO U.L. STD. 508 AND BEAR THE U.L. LABEL "ENCLOSED INDUSTRIAL CONTROL PANEL".
16. 12" (304.8) x 16" (406.4) STAINLESS STEEL EXTERIOR NAMEPLATE SHALL BE ENGRAVED TO "CITY OF ST. CHARLES" UNLESS OTHERWISE SPECIFIED.

FILE NAME = W:\d\stata\22x34\be215.dgn	USER NAME = gaglianobt	DESIGNED - DRAWN - CHECKED - DATE -	REVISED - REVISED - REVISED - REVISED -	08-20-04	STATE OF ILLINOIS DEPARTMENT OF TRANSPORTATION	LIGHTING CONTROLLER SINGLE DOOR			F.A. - RTE.	SECTION 04-00092-00-BR	COUNTY KANE	TOTAL SHEETS 440	SHEET NO. 418
PLOT SCALE = 5/8" = 1' IN.		PLOT DATE = 1/4/2008				SCALE: NONE	SHEET NO. 1 OF 1 SHEETS	STA.	TO STA.	BE-215		CONTRACT NO. 63650	

FED. ROAD DIST. NO. 1 ILLINOIS FED. AID PROJECT

APPLICATION

THIS DETAIL APPLIES FOR LOW VOLTAGE ELECTRIC SERVICE (660 V OR LESS) FROM AN OVERHEAD UTILITY SUPPLY TO SEPERATLY-MOUNTED SERVICE EQUIPMENT.

NOTES

- SERVICE VOLTAGE SHALL BE AS INDICATED ELSEWHERE IN THE DRAWINGS.
- UNLESS OTHERWISE INDICATED, ITEMS AND WORK SHALL BE INCLUDED AND PAID AS PART OF THE ELECTRIC UTILITY SERVICE INSTALLATION PAY ITEM.
- CONDUIT AND CONNECTOR DIAMETER SHALL MATCH THE DIAMETER OF THE SERVICE CONDUCTOR RACEWAY AS INDICATED ON THE PLANS.
- PVC COATED RACEWAYS AND ACCESSORIES SHALL BE CAREFULLY INSTALLED WITH MFR RECOMMENDED TOOLS AND PROCEDURES TO AVOID DAMAGE. ANY DAMAGE SHALL BE REPAIRED WITH COMPATIBLE PVC TOUCH-UP MATERIAL TO THE SATISFACTION OF THE ENGINEER OR THE DAMAGED MATERIAL SHALL BE REPLACED AT NO ADDITIONAL COST.
- THE CONTRACTOR SHALL OBTAIN INSPECTION AND APPROVAL BY THE ENGINEER OF SERVICE RISER GROUND ELECTRODE, RISER ELBOW, NIPPLE AND CONNECTION TO SERVICE CONDUCTOR RACEWAY EXTENSION BEFORE BACKFILL AND SHALL ALSO OBTAIN INSPECTION OF SERVICE RISER AND SEALING BUSHING BEFORE UTILITY "U" GUARD INSTALLATION AND SERVICE CONNECTION.
- THE HORIZONTAL ELECTRIC SERVICE CONDUCTOR RACEWAY SHALL BE AS INDICATED AND SHALL BE MEASURED SEPARATELY FOR PAYMENT. WHEN THE RACEWAY IS PVC-COATED RIGID GALVANIZED STEEL, THE COUPLING SHALL BE THE SAME. WHEN THE RACEWAY IS PVC CONDUIT (IN CONCRETE), THE COUPLING SHALL BE A METALIC TO NON METALIC ADAPTER. WHEN THE RACEWAY IS ENCASED IN CONCRETE, THE CONCRETE SHALL EXTEND TO COVER THE COUPLING.
- PLANS AND DETAILS INDICATE THE GENERAL NATURE AND REQUIREMENTS. THEY DO NOT SHOW EVERY ACCESSORY AND ATTACHMENT, AND THEY DO NOT RELIEVE THE CONTRACTOR OF THE REQUIREMENTS OF THE SPECIFICATIONS AND SPECIAL PROVISIONS TO ASCERTAIN UTILITY REQUIREMENTS AND TO COORDINATE ACCORDINGLY, FURNISHING ALL ITEMS AND WORK NOT PROVIDED BY THE UTILITY, BUT NECESSARY FOR A COMPLETE SERVICE INSTALLATION IS REQUIRED AND SHALL BE INCLUDED IN THE ELECTRIC UTILITY SERVICE INSTALLATION PAY ITEM.

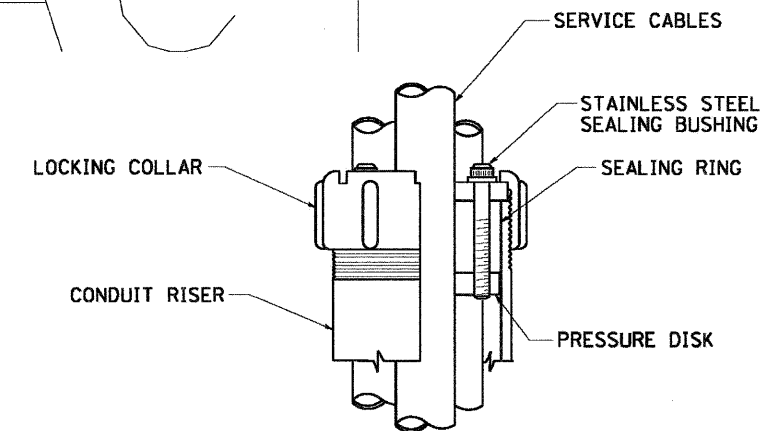

SEALING BUSHING DETAIL

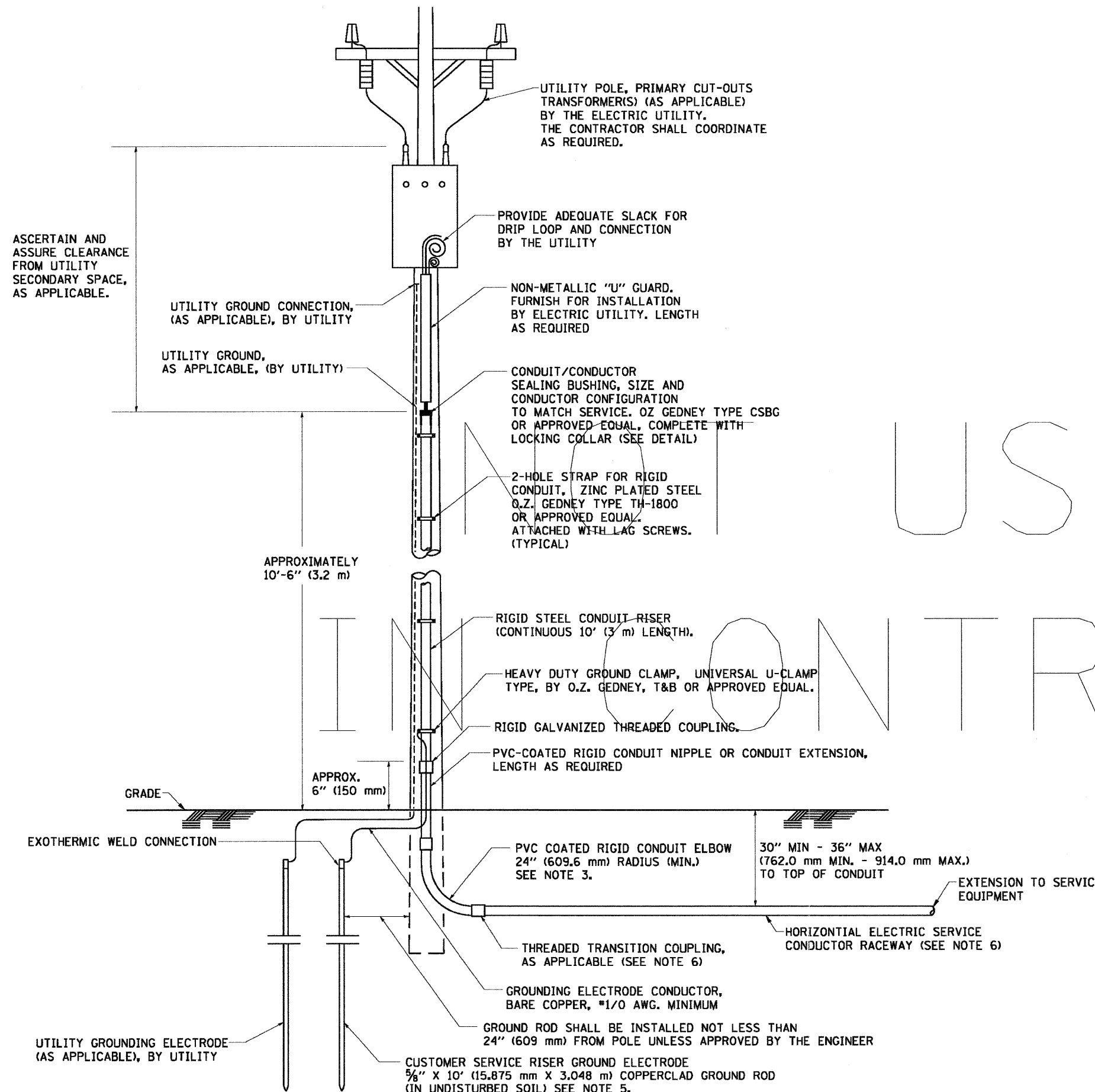

FILE NAME = W:\dstatd\22x34\be228.dgn	USER NAME = gaglianobt	DESIGNED -	REVISED - 03-03-06	STATE OF ILLINOIS DEPARTMENT OF TRANSPORTATION	ELECTRIC SERVICE INSTALLATION AERIAL REMOTE DISCONNECT			F.A. RTE. -	SECTION	COUNTY	TOTAL SHEETS	SHEET NO.
	PLOT SCALE = 50.0000" / IN.	DRAWN -	REVISED -		SCALE: NONE	SHEET NO. 1 OF 1 SHEETS	STA.	TO STA.	04-00092-00-BR	KANE	440	419
	PLOT DATE = 1/4/2008	CHECKED - MEA	REVISED -					BE-220		CONTRACT NO. 63650		
		DATE -	REVISED -		<small>FED. ROAD DIST. NO. 1 ILLINOIS FED. AID PROJECT</small>							

LIGHT POLE FOUNDATION DEPTH TABLE
30 FT. (9.144 m) TO 35 FT. (10.668 m) MOUNTING HEIGHT

SOIL CONDITIONS	DESIGN DEPTH "D" OF FOUNDATION	
	SINGLE ARM POLE	TWIN ARM POLE
SOFT CLAY Ou = 0.375 TON/SQ. FT.	11'-0" (3.35 m)	12'-8" (3.85 m)
MEDIUM CLAY Ou = 0.75 TON/SQ.FT	9'-0" (2.74 m)	14'-10" (4.52 m)
STIFF CLAY Ou = 1.50 TON/SO. FT.	7'-6" (2.29 m)	8'-7" (2.61 m)
LOOSE SAND φ = 34°	9'-6" (2.90 m)	10'-7" (3.22 m)
MEDIUM SAND φ = 37.5°	9'-0" (2.74 m)	9'-10" (2.99 m)
DENSE SAND φ = 40°	8'-3" (2.51 m)	9'-7" (2.91 m)

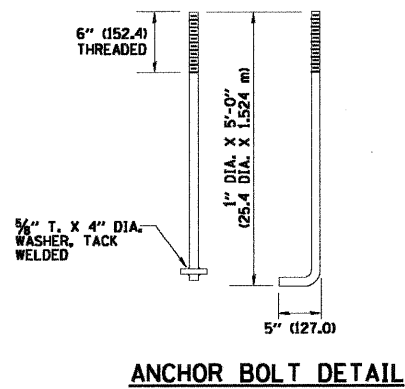
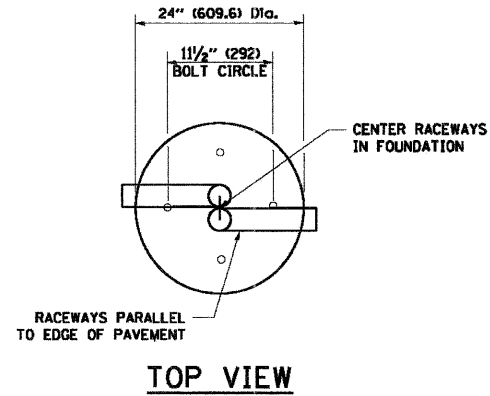

ANCHOR BOLT DETAIL

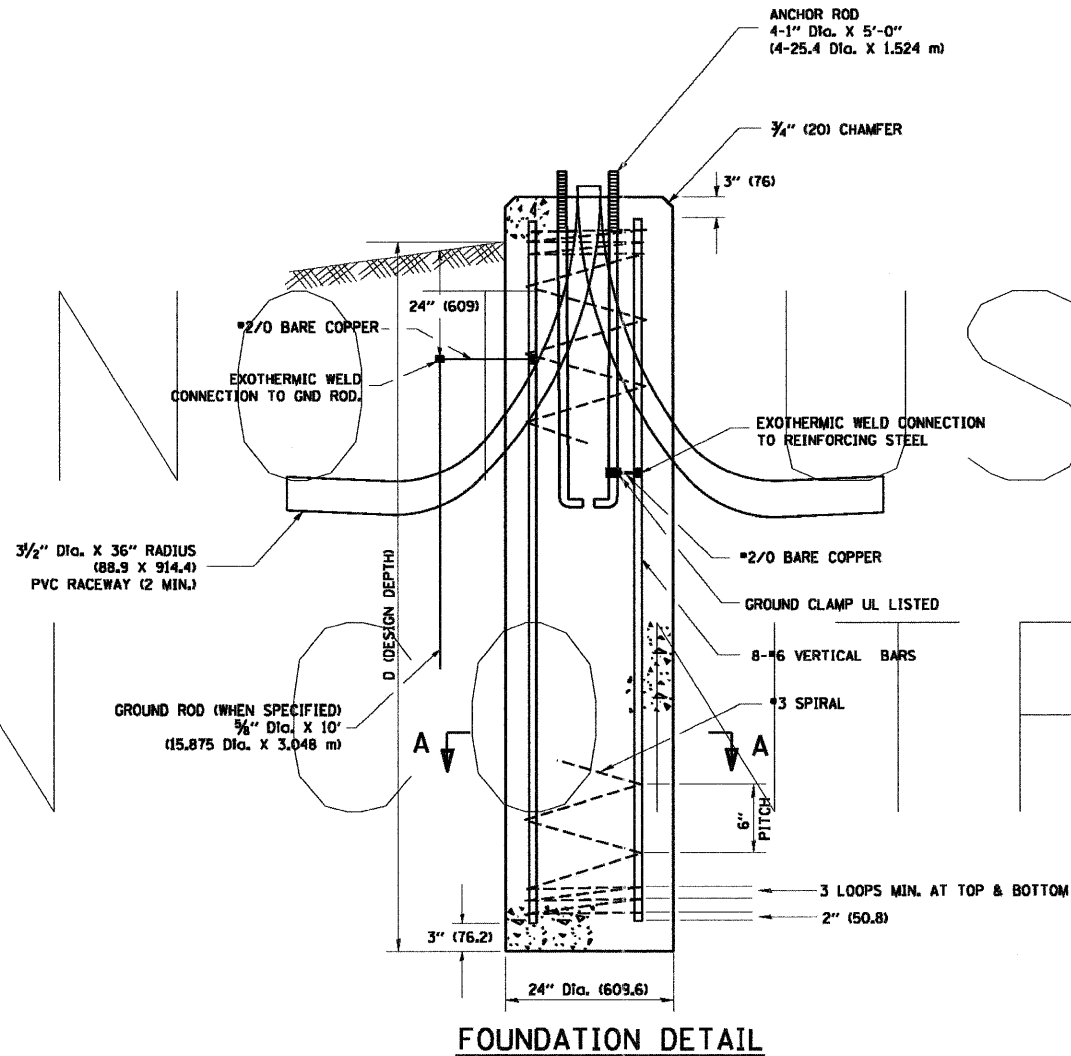

FOUNDATION DETAIL

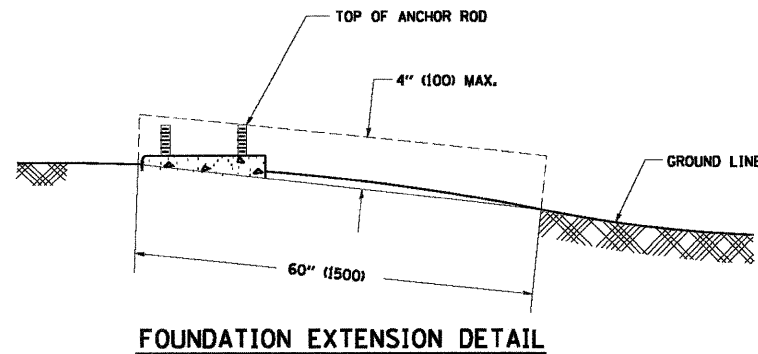

FOUNDATION EXTENSION DETAIL

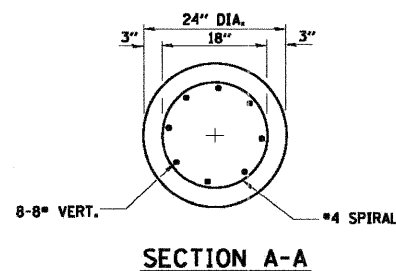

SECTION A-A

NOTES

- ALL DIMENSIONS ARE IN INCHES (MILLIMETERS) UNLESS OTHERWISE SHOWN.
- THE ANCHOR RODS AND RACEWAYS SHALL BE PROPERLY SECURED IN PLACE BEFORE THE CONCRETE IS PLACED.
- THE FOUNDATION SHALL NOT PROTRUDE MORE THAN 4 IN. (100 mm) ABOVE THE FINISHED GRADE WITHIN A 60 IN. (1.5 m) CHORD ACROSS THE FOUNDATION, WITH ANCHOR RODS INCLUDED, IN ACCORDANCE WITH AASHTO GUIDELINES. IF THE FOUNDATION HEIGHT, INCLUDING ANCHOR RODS, EXTENDS BEYOND THESE SPECIFIED LIMITS, THE FOUNDATION SHALL BE REPLACED AT THE CONTRACTOR'S EXPENSE. SEE FOUNDATION EXTENSION DETAIL.
- THE HOLE FOR THE FOUNDATION SHALL BE MADE BY DRILLING WITH AN AUGER, OF THE SAME DIAMETER AS THE FOUNDATION. IF SOIL CONDITIONS REQUIRE THE USE OF A LINER TO FORM THE HOLE, THE LINER SHALL BE WITHDRAWN AS THE CONCRETE IS DEPOSITED.
- THE TOP OF THE FOUNDATION SHALL BE CONSTRUCTED LEVEL. A LINER OR FORM SHALL BE USED TO PRODUCE A UNIFORM SMOOTH SIDE TO THE TOP OF THE FOUNDATION. FOUNDATION TOP SHALL BE CHAMFERED 3/4-IN. (20 mm).
- THE CONCRETE SHALL BE CLASS SI. CONCRETE SHALL CURE ACCORDING TO ARTICLE 1020.13 BEFORE LIGHT POLES ARE INSTALLED.
- THE ANCHOR ROD SHALL BE A HOOK ROD TYPE. COLD BENDING OF THE ANCHOR ROD WILL NOT BE ALLOWED. THE RADIUS OF THE HOOK BEND SHALL NOT BE LESS THAN 4 TIMES THE NOMINAL DIAMETER OF THE ANCHOR ROD. A TACK WELDED ANCHOR ROD MAY BE SUBSTITUTED WITH THE APPROVAL OF THE ENGINEER.
- THE ANCHOR RODS SHALL BE ACCORDING TO ASTM F1554 GRADE 725 (GRADE 105). NUTS SHALL BE HEXAGON NUTS ACCORDING TO ASTM A 194 2H OR ASTM A 563 DH, AND WASHERS SHALL BE ACCORDING TO ASTM F 436.
- ANCHOR RODS, NUTS AND WASHERS SHALL BE COMPLETELY GALVANIZED BY EITHER THE HOT-DIPPED PROCESS CONFORMING WITH AASHTO M 232, THE MECHANICAL PLATING METHOD CONFORMING TO AASHTO M 298, CLASS 50 WITH A MAXIMUM COATING THICKNESS OF 150 (6 MILS) OR THE ELECTROLYTIC PROCESS ACCORDING TO ASTM F 1136.
- THE ANCHOR RODS SHALL BE THREADED A MINIMUM OF 6 INCHES (150 mm) WITH A MINIMUM OF 3 INCHES (75 mm) OF THREADED ANCHOR ROD EMBEDDED IN THE FOUNDATION.
- ANCHOR RODS SHALL PROJECT 2 3/4" (69.9 mm) ABOVE THE TOP OF THE FOUNDATION. IF BREAKAWAY COUPLINGS ARE SPECIFIED, THE CONTRACTOR SHALL CAREFULLY COORDINATE THE ANCHOR ROD PROJECTION WITH THE INSTALLATION REQUIREMENTS OF THE BREAKAWAY COUPLINGS.
- THE CONTRACTOR SHALL USE A #3 SPIRAL AT 6" (152.4 mm) PITCH OR MAY SUBSTITUTE #3 TIES AT 12" (304.8 mm) O.C. WITH THE APPROVAL OF THE ENGINEER.
- THE CABLE TRENCHES AND FOUNDATION SHALL BE BACK FILLED AND COMPACTED AS SPECIFIED BEFORE THE LIGHT POLE IS ERECTED.
- THE RACEWAYS SHALL PROJECT 1" (25.4 mm) ABOVE THE TOP OF THE FOUNDATION.

LIGHT POLE FOUNDATION DEPTH TABLE
40 FT. (12.192 m) TO 47.5 FT. (14.478 m) MOUNTING HEIGHT

SOIL CONDITIONS	DESIGN DEPTH "D" OF FOUNDATION	
	SINGLE ARM POLE	TWIN ARM POLE
SOFT CLAY Qu = 0.375 TON/SQ. FT.	13'-0" (3.96 m)	15'-0" (4.57 m)
MEDIUM CLAY Qu = 0.75 TON/SQ.FT	9'-6" (2.93 m)	10'-9" (3.23 m)
STIFF CLAY Qu = 1.50 TON/SQ. FT.	7'-0" (2.13 m)	8'-0" (2.44 m)
LOOSE SAND φ = 34°	9'-0" (2.74 m)	10'-0" (3.05 m)
MEDIUM SAND φ = 37.5°	8'-3" (2.52 m)	9'-0" (2.74 m)
DENSE SAND φ = 40°	7'-9" (2.36 m)	9'-0" (2.74 m)

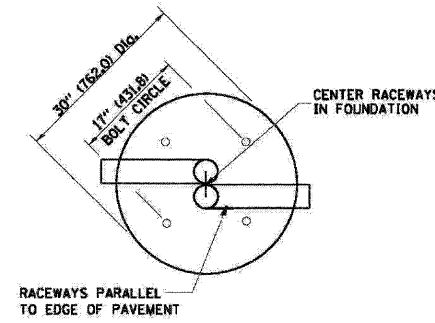
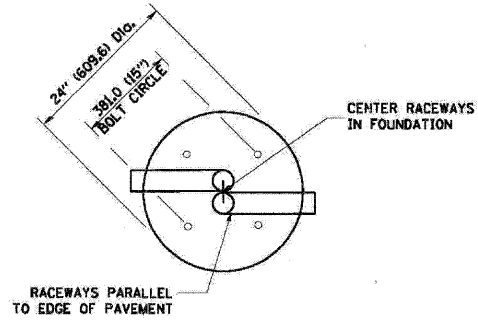

TOP VIEW

TOP VIEW

NOTES

- ALL DIMENSIONS ARE IN INCHES (MILLIMETERS) UNLESS OTHERWISE SHOWN.
- THE ANCHOR RODS AND RACEWAYS SHALL BE PROPERLY SECURED IN PLACE BEFORE THE CONCRETE IS PLACED.
- THE FOUNDATION SHALL NOT PROTRUDE MORE THAN 100MM (4 IN.) ABOVE THE FINISHED GRADE WITHIN A 60 IN. (1.5 m) CHORD ACROSS THE FOUNDATION, WITH ANCHOR RODS INCLUDED, IN ACCORDANCE WITH AASHTO GUIDELINES. IF THE FOUNDATION HEIGHT, INCLUDING ANCHOR RODS, EXTENDS BEYOND THESE SPECIFIED LIMITS, THE FOUNDATION SHALL BE REPLACED AT THE CONTRACTOR'S EXPENSE. SEE FOUNDATION EXTENSION DETAIL.
- THE HOLE FOR THE FOUNDATION SHALL BE MADE BY DRILLING WITH AN ALJER, OF THE SAME DIAMETER AS THE FOUNDATION. IF SOIL CONDITIONS REQUIRE THE USE OF A LINER TO FORM THE HOLE, THE LINER SHALL BE WITHDRAWN AS THE CONCRETE IS DEPOSITED.
- THE TOP OF THE FOUNDATION SHALL BE CONSTRUCTED LEVEL. A LINER OR FORM SHALL BE USED TO PRODUCE A UNIFORM SMOOTH SIDE TO THE TOP OF THE FOUNDATION. FOUNDATION TOP SHALL BE CHAMFERED 3/4-IN. (20 mm).
- THE CONCRETE SHALL BE CLASS S1. CONCRETE SHALL CURE ACCORDING TO ARTICLE 1020.13 BEFORE LIGHT POLES ARE INSTALLED.
- THE ANCHOR ROD SHALL BE A HOOK ROD TYPE. COLD BENDING OF THE ANCHOR ROD WILL NOT BE ALLOWED. THE RADIUS OF THE HOOK BEND SHALL NOT BE LESS THAN 4 TIMES THE NOMINAL DIAMETER OF THE ANCHOR ROD. A TACK WELDED ANCHOR ROD MAY BE SUBSTITUTED WITH THE APPROVAL OF THE ENGINEER.
- THE ANCHOR RODS SHALL BE ACCORDING TO ASTM F1554 GRADE 725 (GRADE 105). NUTS SHALL BE HEXAGON NUTS ACCORDING TO ASTM A 194 2H OR ASTM A 563 DH, AND WASHERS SHALL BE ACCORDING TO ASTM F 436.
- ANCHOR RODS, NUTS AND WASHERS SHALL BE COMPLETELY GALVANIZED BY EITHER THE HOT-DIPPED PROCESS CONFORMING WITH AASHTO M 232, THE MECHANICAL PLATING METHOD CONFORMING TO AASHTO M 298, CLASS 50 WITH A MAXIMUM COATING THICKNESS OF 150 UMG MILS) OR THE ELECTROLYTIC PROCESS ACCORDING TO ASTM F 1136.
- THE ANCHOR RODS SHALL BE THREADED A MINIMUM OF 6 INCHES (150 mm) WITH A MINIMUM OF 3 INCHES (75 mm) OF THREADED ANCHOR ROD EMBEDDED IN THE FOUNDATION.
- ANCHOR RODS SHALL PROJECT 2 3/4" (69.9 mm) ABOVE THE TOP OF THE FOUNDATION. IF BREAKAWAY COUPLINGS ARE SPECIFIED, THE CONTRACTOR SHALL CAREFULLY COORDINATE THE ANCHOR ROD PROJECTION WITH THE INSTALLATION REQUIREMENTS OF THE BREAKAWAY COUPLINGS.
- THE CONTRACTOR SHALL USE A #3 SPIRAL AT 6" (152.4 mm) PITCH OR MAY SUBSTITUTE #3 TIES AT 12" (304.8 mm) O.C. WITH THE APPROVAL OF THE ENGINEER.
- THE CABLE TRENCHES AND FOUNDATION SHALL BE BACK FILLED AND COMPACTED AS SPECIFIED BEFORE THE LIGHT POLE IS ERECTED.
- THE RACEWAYS SHALL PROJECT 1" (25.4 mm) ABOVE THE TOP OF THE FOUNDATION.

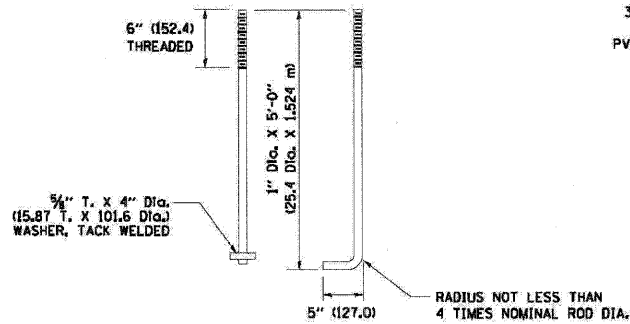

ANCHOR ROD DETAIL

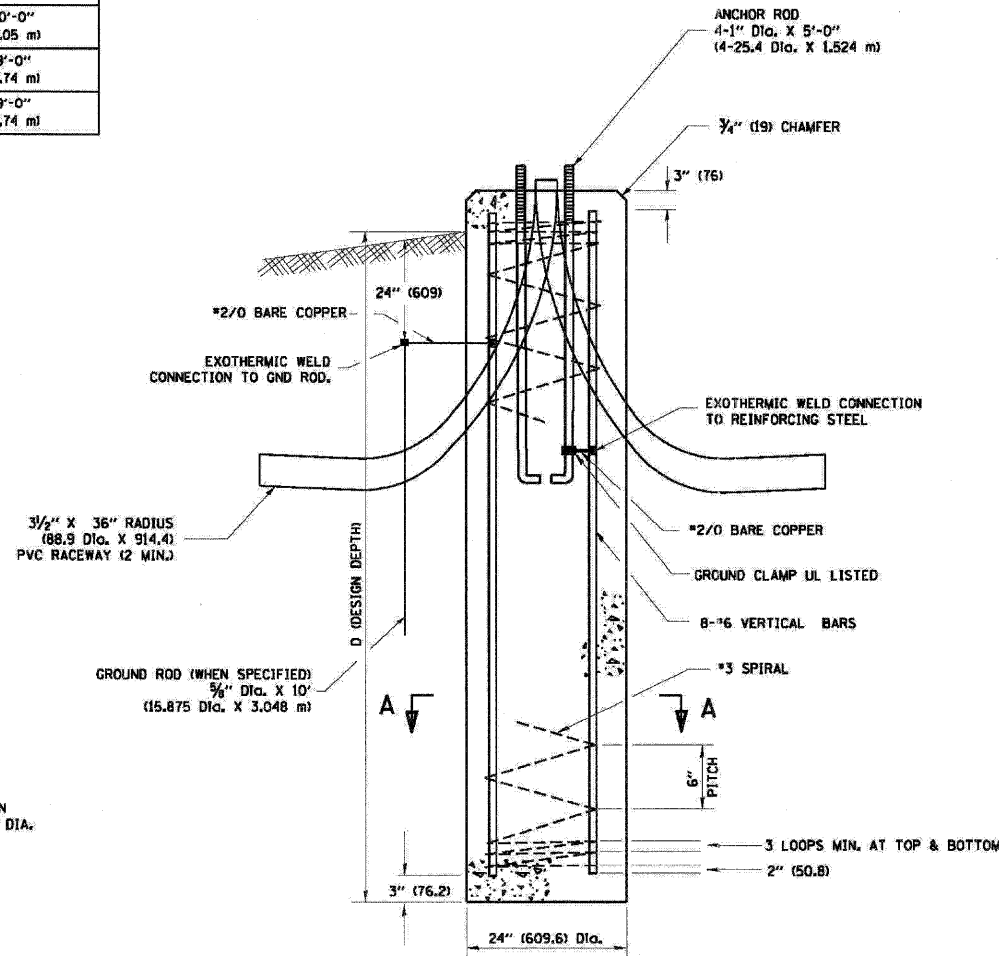

FOUNDATION DETAIL

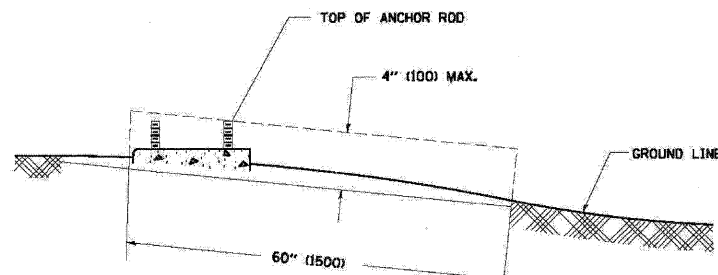

FOUNDATION EXTENSION DETAIL

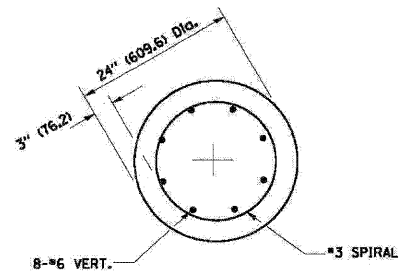

SECTION A-A

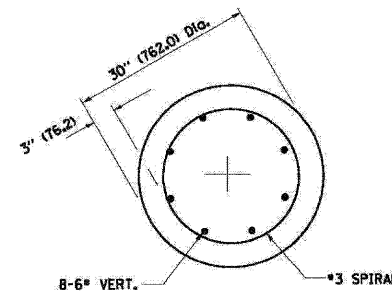

SECTION A-A

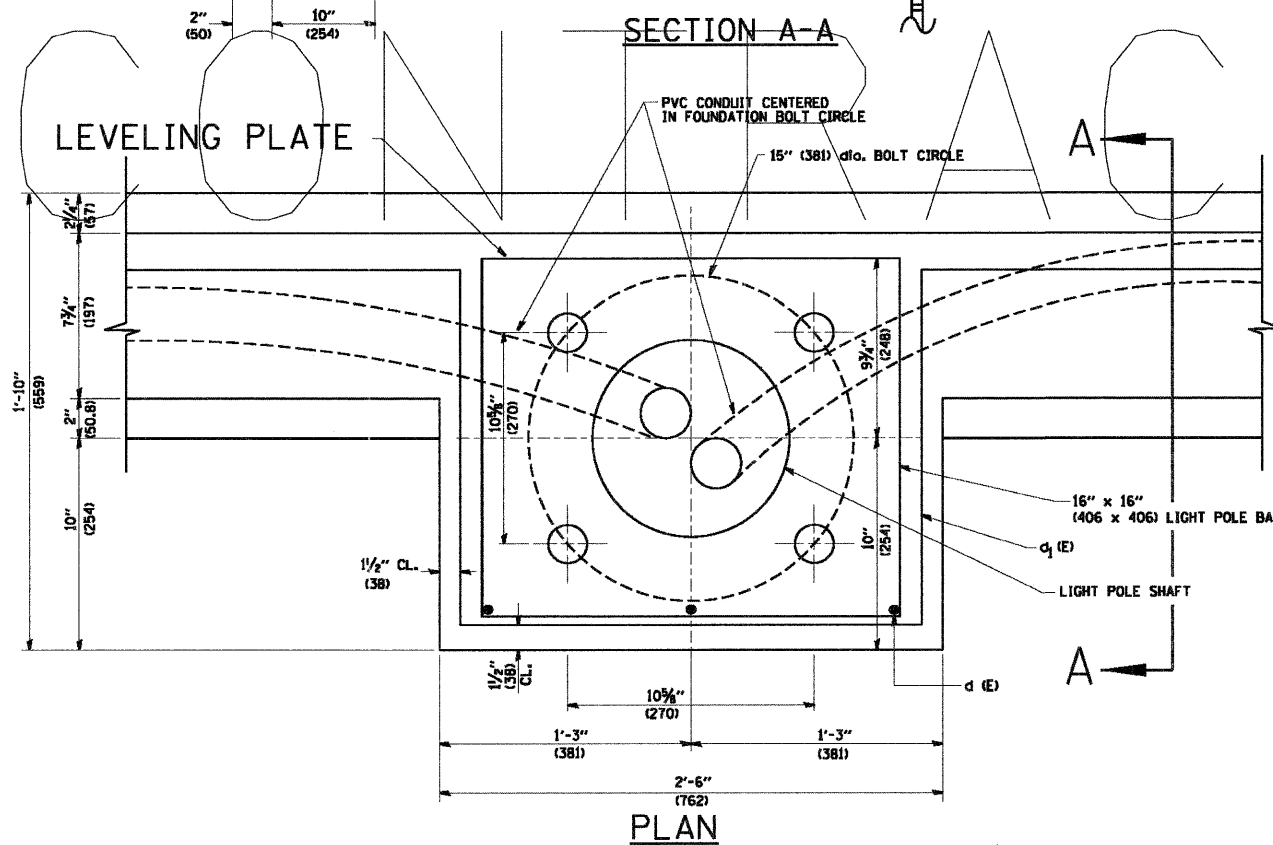
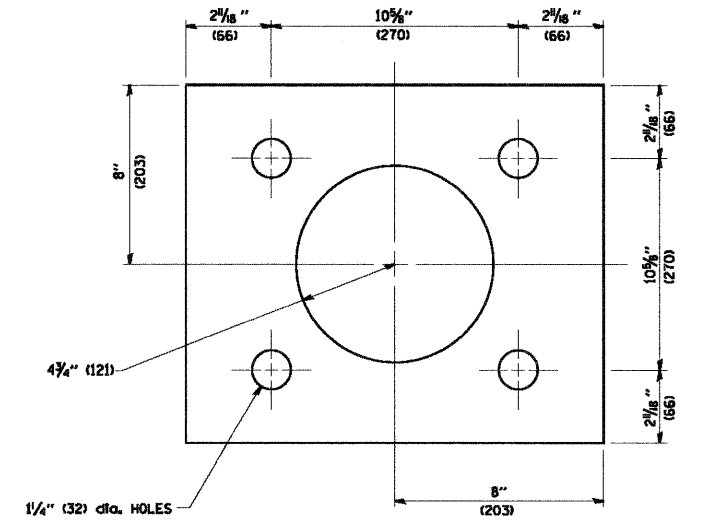
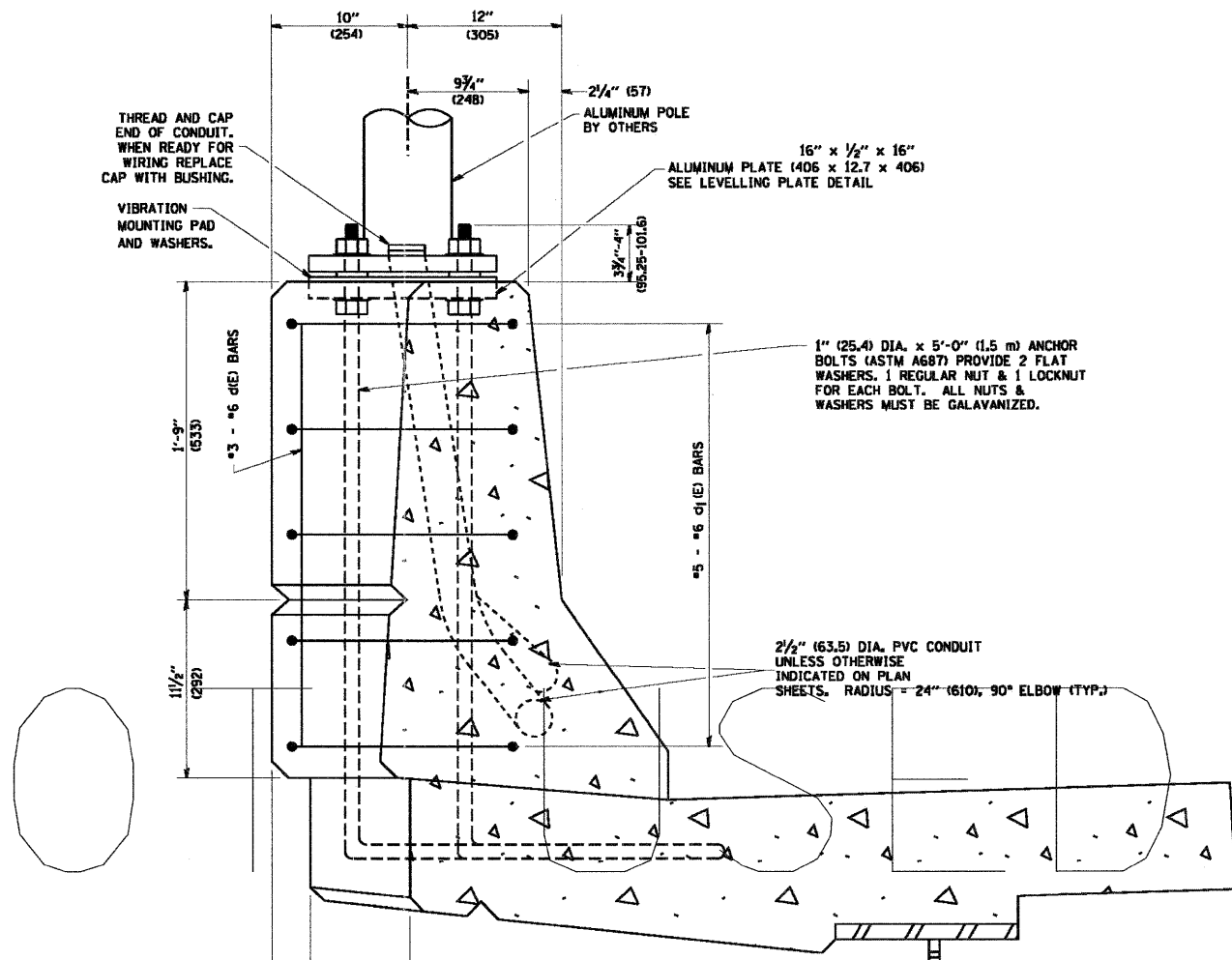
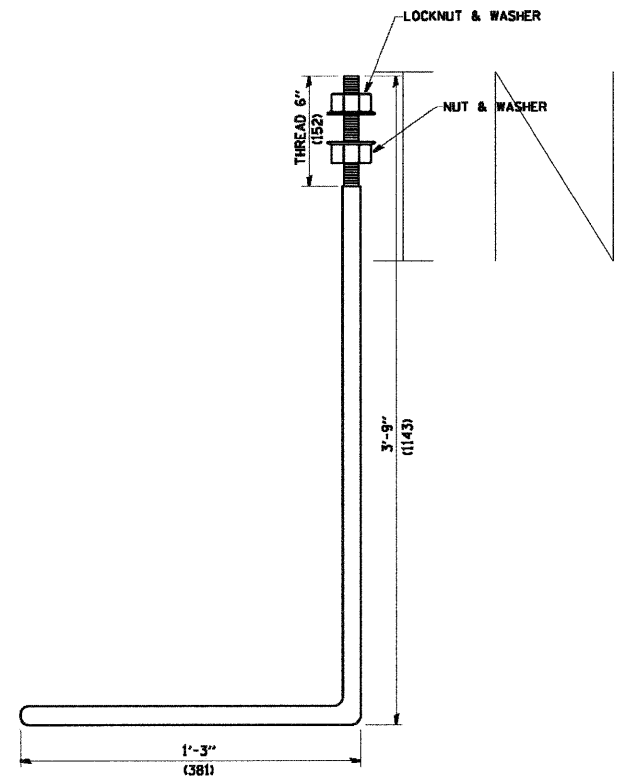
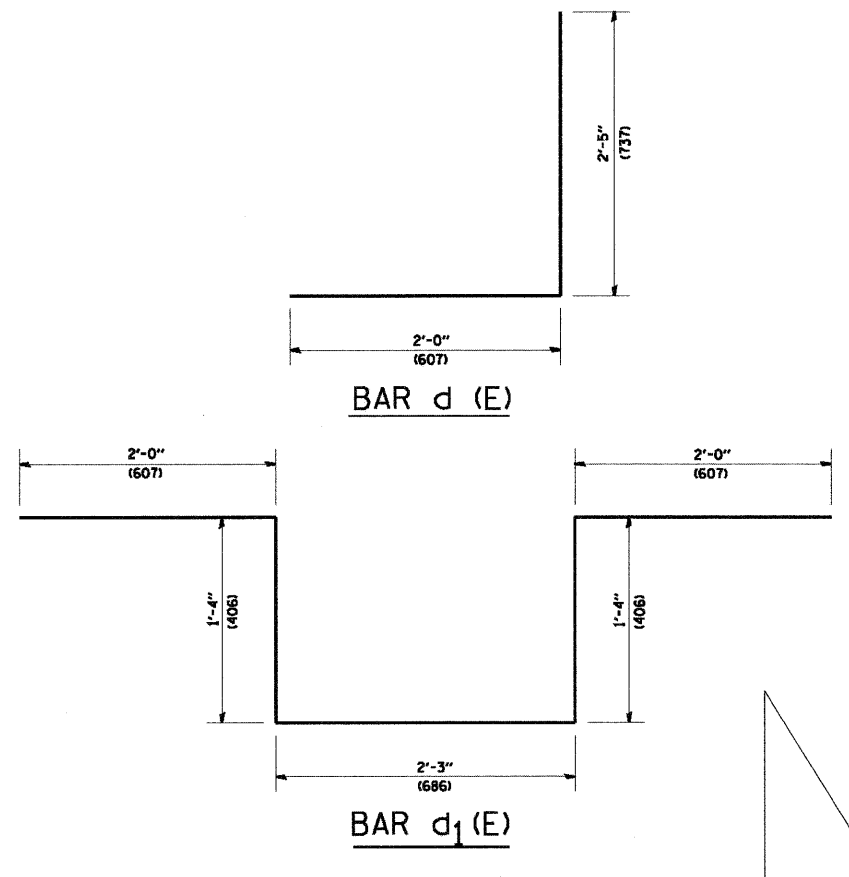

- NOTES**
- ALL DIMENSIONS ARE IN INCHES (MILLIMETERS) UNLESS OTHERWISE SHOWN.
 - LEVEL LIGHT POLE PLATES, USING THE FLANGE NUTS, PRIOR TO POURING THE PARAPET WALL. THE TOP OF THE PLATE SHALL BE AT THE SAME ELEVATION AS THE FINISHED CONCRETE PARAPET.
 - THE COST OF ANCHOR BOLTS, CONDUIT, LEVELLING PLATE AND FOUNDATION IS INCLUDED IN THE COST OF THE BRIDGE STRUCTURE.

FILE NAME = W:\dststd\22x34\be338.dgn	USER NAME = goglianebt	DESIGNED -	REVISED - 04-22-02	STATE OF ILLINOIS DEPARTMENT OF TRANSPORTATION	LIGHT POLE MOUNTED ON CONCRETE PARAPET WALL 15" (381 mm) BOLT CIRCLE			F.A. RTE. -	SECTION - 04-00092-00-BR	COUNTY - KANE	TOTAL SHEETS - 440	SHEET NO. - 422
	PLOT SCALE = 50.0000' / IN.	DRAWN -	REVISED -		SCALE: NONE	SHEET NO. 1 OF 1 SHEETS	STA. -	TO STA. -	BE-330		CONTRACT NO. 63650	
	PLOT DATE = 1/4/2008	CHECKED -	REVISED -						FED. ROAD DIST. NO. 1		ILLINOIS FED. AID PROJECT	
		DATE -	REVISED -									

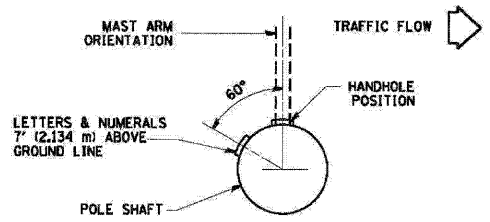

POSITION OF HANDHOLE AND POLE NUMBER FOR SINGLE MAST ARM POLES MOUNTED ON BRIDGE PARAPET OR BARRIER WALL

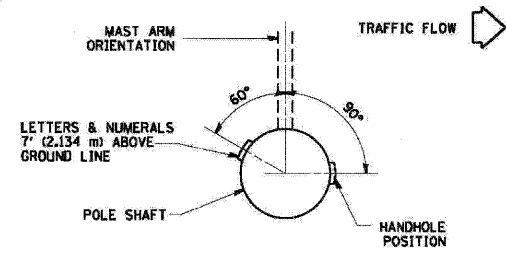

POSITION OF HANDHOLE AND POLE NUMBER FOR SINGLE MAST ARM POLES

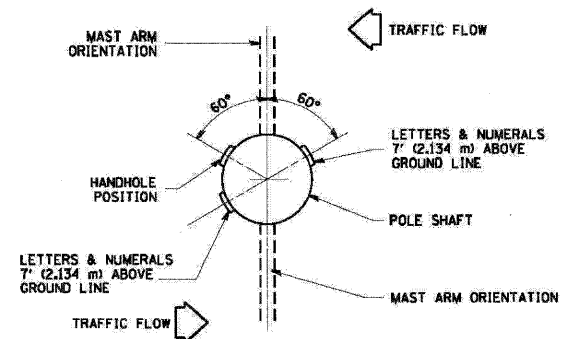

POSITION OF HANDHOLE AND POLE NUMBER FOR TWIN MAST ARM POLES

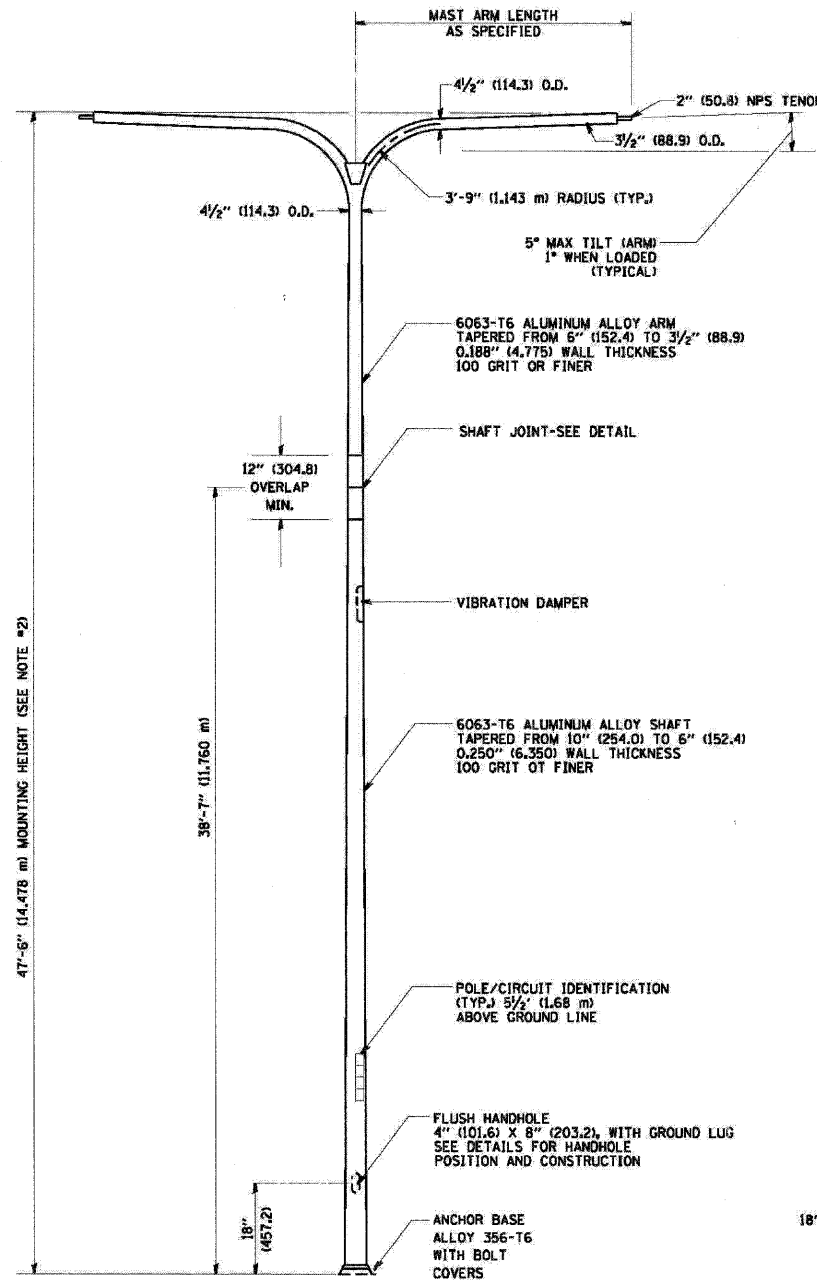

TWIN ARM POLE

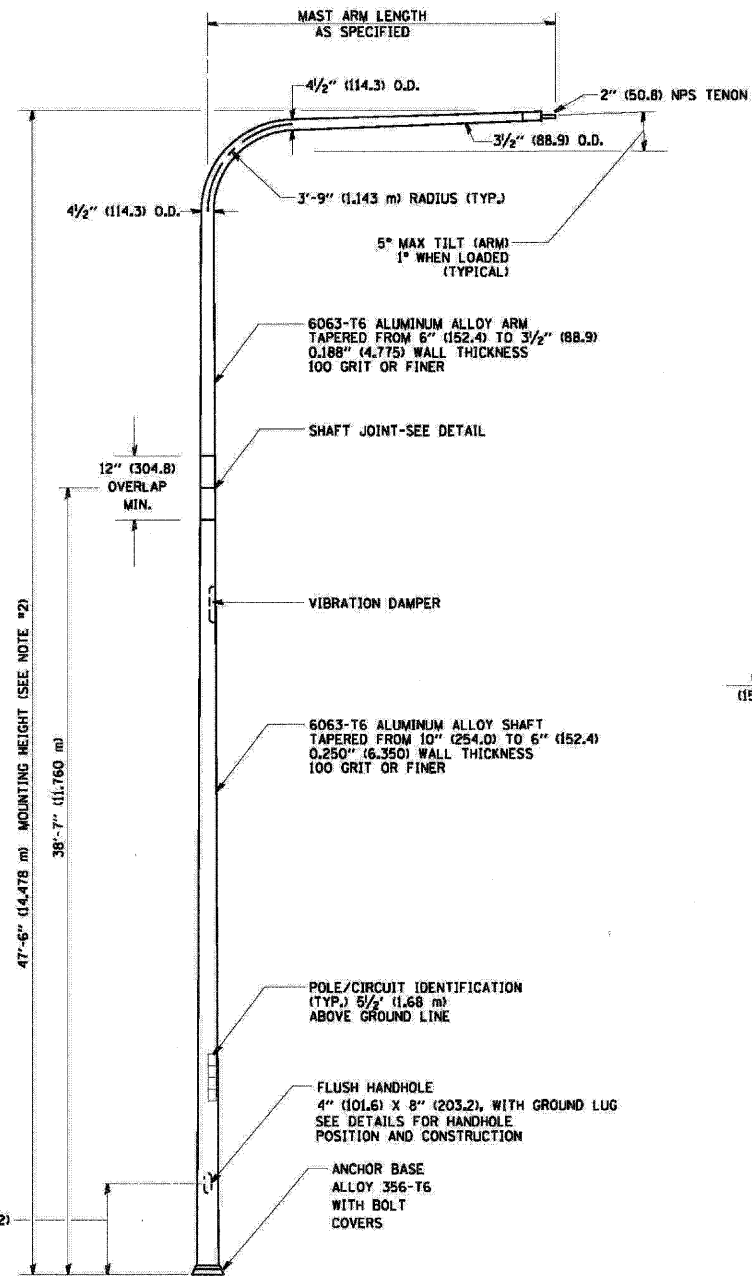

SINGLE ARM POLE

- NOTES:**
1. ALL DIMENSIONS ARE IN INCHES (MILLIMETERS) UNLESS OTHERWISE SHOWN.
 2. MOUNTING HEIGHT IS DEFINED AS THE DISTANCE FROM THE CENTERLINE OF THE TENON TO THE BOTTOM OF THE ANCHOR BASE.
 3. TWO PIECE SHAFT WILL BE MATCHED MARKED AND INTERCHANGEABLE BETWEEN DIFFERENT UNITS. FIELD DRILLING OF THE HOLES WILL NOT BE ALLOWED.
 4. THE LIGHT POLE WILL MEET AASHTO DESIGN CRITERIA AS SPECIFIED.
 5. THE INSTALLING CONTRACTOR WILL PROVIDE A UL LISTED GROUNDING CONNECTOR, BURNDY K2C23, T&B SP4DL OR APPROVED EQUAL.
 6. LIGHT POLES WILL NOT BE INSTALLED WITHOUT MAST ARMS AND LUMINAIRES.
 7. LIGHT POLES WILL BE SET PLUMB ON THE FOUNDATION WITHOUT THE USE OF LEVELING NUTS, WASHERS OR SHIMS.
 8. LIGHTING UNIT IDENTIFICATION NUMBERS SHALL BE INSTALLED BEFORE THE LIGHTING UNIT IS ENERGIZED.

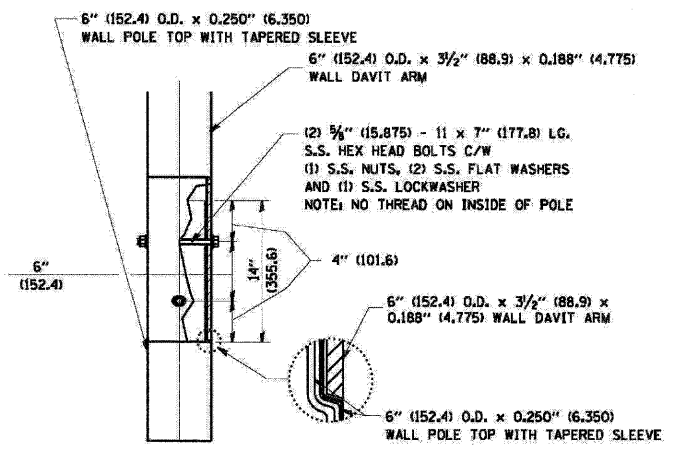

DAVIT ARM CONNECTION
[14" (355.6) OVERLAP SHOWN]

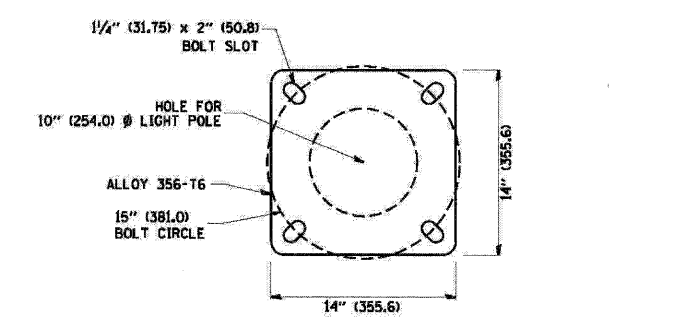

LIGHT POLE BASE PLATE DETAIL
(FOR POLE MOUNTED ON 15 INCH (381.0) BOLT CIRCLE FOUNDATION)

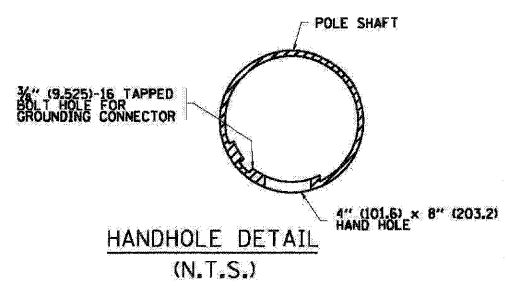

HANDHOLE DETAIL
(N.T.S.)

FILE NAME = W:\ad\stata\22x34\be#10.dgn	USER NAME = gajlanobt	DESIGNED - DRAWN - LEY	REVISED - D. DREW 04-02-92 REVISED - D. DREW 05-07-92	STATE OF ILLINOIS DEPARTMENT OF TRANSPORTATION	DAVIT LIGHT POLE 47'-6" (14.478 m) MOUNTING HEIGHT			F.A. - RTE.	SECTION 04-00092-00-BR	COUNTY KANE	TOTAL SHEETS 440	SHEET NO. 423
PLT SCALE = 50.0000 X 1/8 IN.	PLT DATE = 1/4/2008	CHECKED - DATE -	REVISED - R. TOMSONS 09-06-00 REVISED - R. TOMSONS 09-02-03		SCALE: NONE	SHEET NO. 1 OF 1 SHEETS	STA. TO STA.	BE-410 CONTRACT NO. 63650				
FED. ROAD DIST. NO. 1 (ILLINOIS) FED. AID PROJECT												

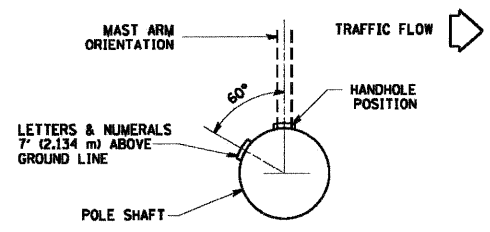

POSITION OF HANDHOLE AND POLE NUMBER FOR SINGLE MAST ARM POLES MOUNTED ON BRIDGE PARAPET OR BARRIER WALL

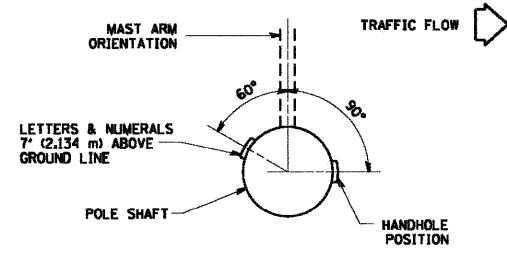

POSITION OF HANDHOLE AND POLE NUMBER FOR SINGLE MAST ARM POLES

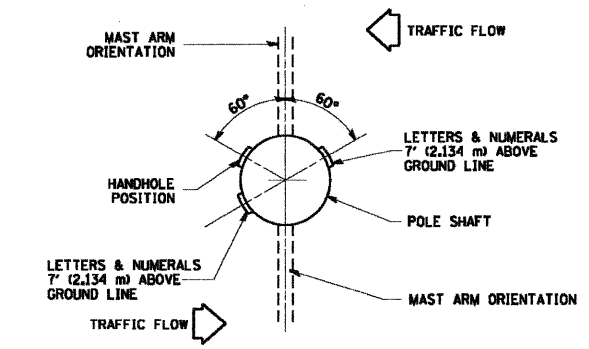

POSITION OF HANDHOLE AND POLE NUMBER FOR TWIN MAST ARM POLES

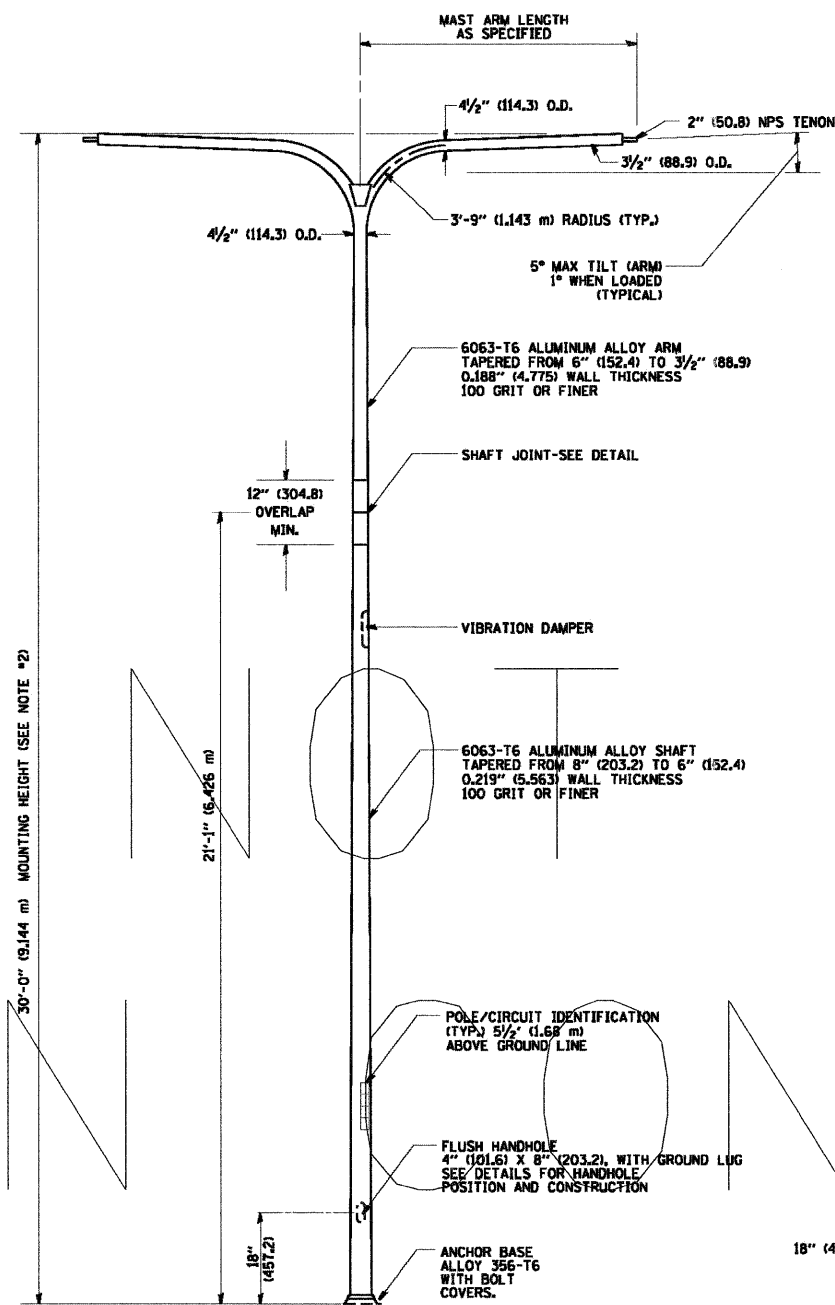

TWIN ARM POLE

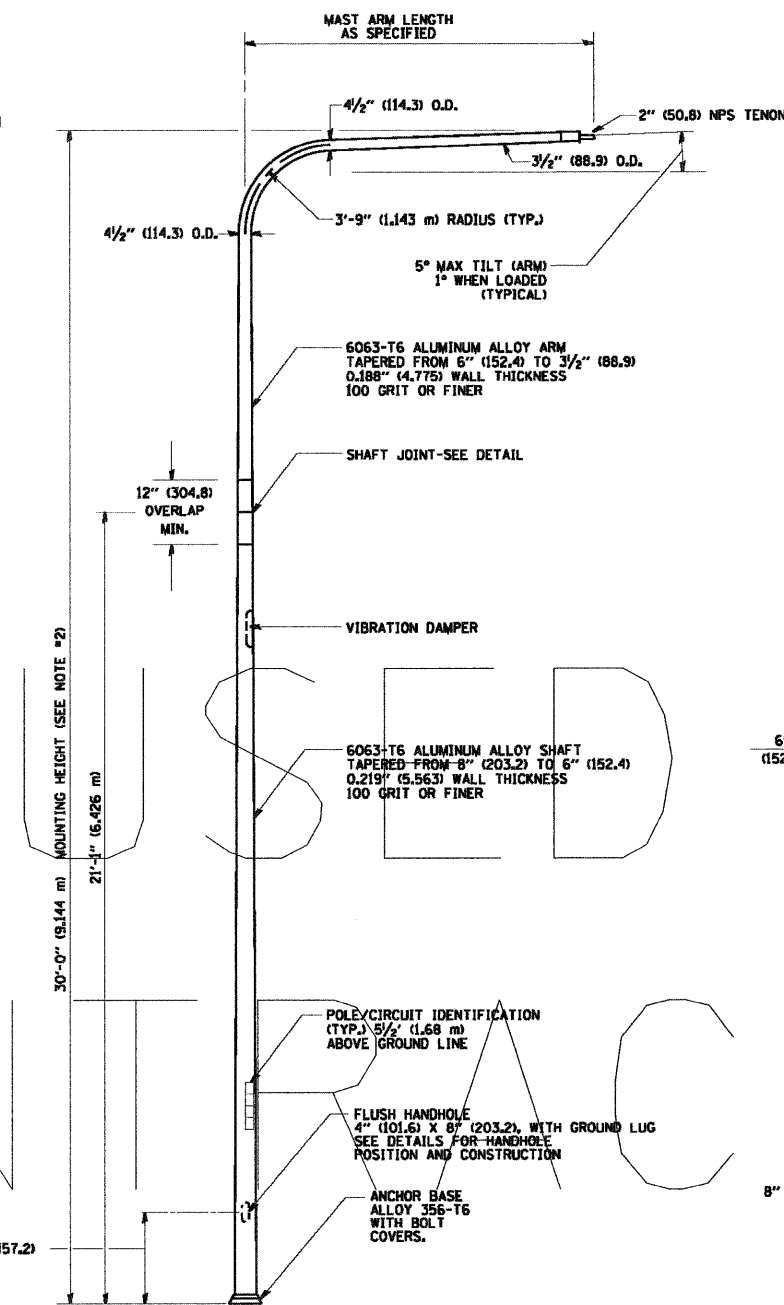

SINGLE ARM POLE

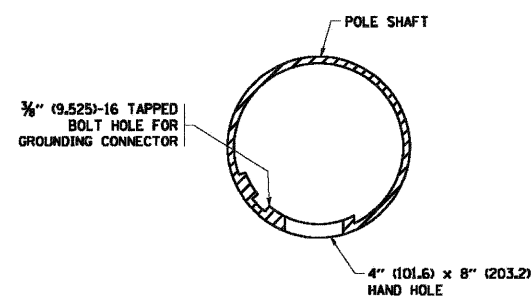

HANDHOLE DETAIL (N.T.S.)

- NOTES:
- ALL DIMENSIONS ARE IN INCHES (MILLIMETERS) UNLESS OTHERWISE SHOWN.
 - MOUNTING HEIGHT IS DEFINED AS THE DISTANCE FROM THE CENTERLINE OF THE TENON TO THE BOTTOM OF THE ANCHOR BASE.
 - TWO Poles WILL BE MATCHED MARKED AND INTERCHANGEABLE BETWEEN DIFFERENT UNITS. FIELD DRILLING OF THE HOLES WILL NOT BE ALLOWED.
 - THE LIGHT POLE WILL MEET AASHTO DESIGN CRITERIA AS SPECIFIED.
 - THE INSTALLING CONTRACTOR WILL PROVIDE A LISTED GROUNDING CONNECTOR, BURNDY K2C23, T&B SP4DL OR APPROVED EQUAL.
 - LIGHT POLES WILL NOT BE INSTALLED WITHOUT MAST ARMS AND LUMINAIRES.
 - LIGHT POLES WILL BE SET PLUMB ON THE FOUNDATION WITHOUT THE USE OF LEVELING NUTS, WASHERS OR SHIMS.
 - LIGHTING UNIT IDENTIFICATION NUMBERS SHALL BE INSTALLED BEFORE THE LIGHTING UNIT IS ENERGIZED.

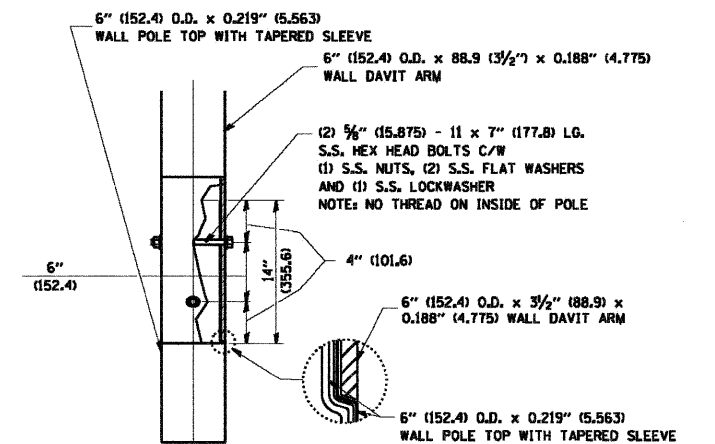

DAVIT ARM CONNECTION [14" (355.6) OVERLAP SHOWN]

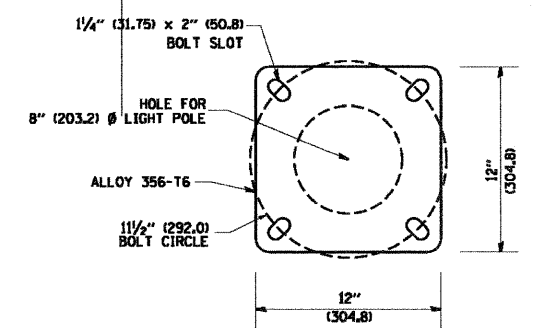

LIGHT POLE BASE PLATE DETAIL 11 1/2" (292.0) BOLT CIRCLE

FILE NAME = W:\dstata\22x34\be413.dgn	USER NAME = gaglianob	DESIGNED -	REVISED - D. DREW 04-02-92	STATE OF ILLINOIS DEPARTMENT OF TRANSPORTATION	DAVIT LIGHT POLE		F.A. RTE. =	SECTION	COUNTY	TOTAL SHEETS	SHEET NO.
		DRAWN - RL	REVISED - D. DREW 05-07-92		30'-0" (9.144 m) MOUNTING HEIGHT			04-00092-00-BR	KANE	440	424
		CHECKED -	REVISED - R. TOMSONS 09-06-00		SCALE: NONE		SHEET NO. 1 OF 1 SHEETS	BE-413	CONTRACT NO. 63650		
		DATE -	REVISED - R. TOMSONS 09-02-03		STA. TO STA.		FED. ROAD DIST. NO. 1 ILLINOIS FED. AID PROJECT				

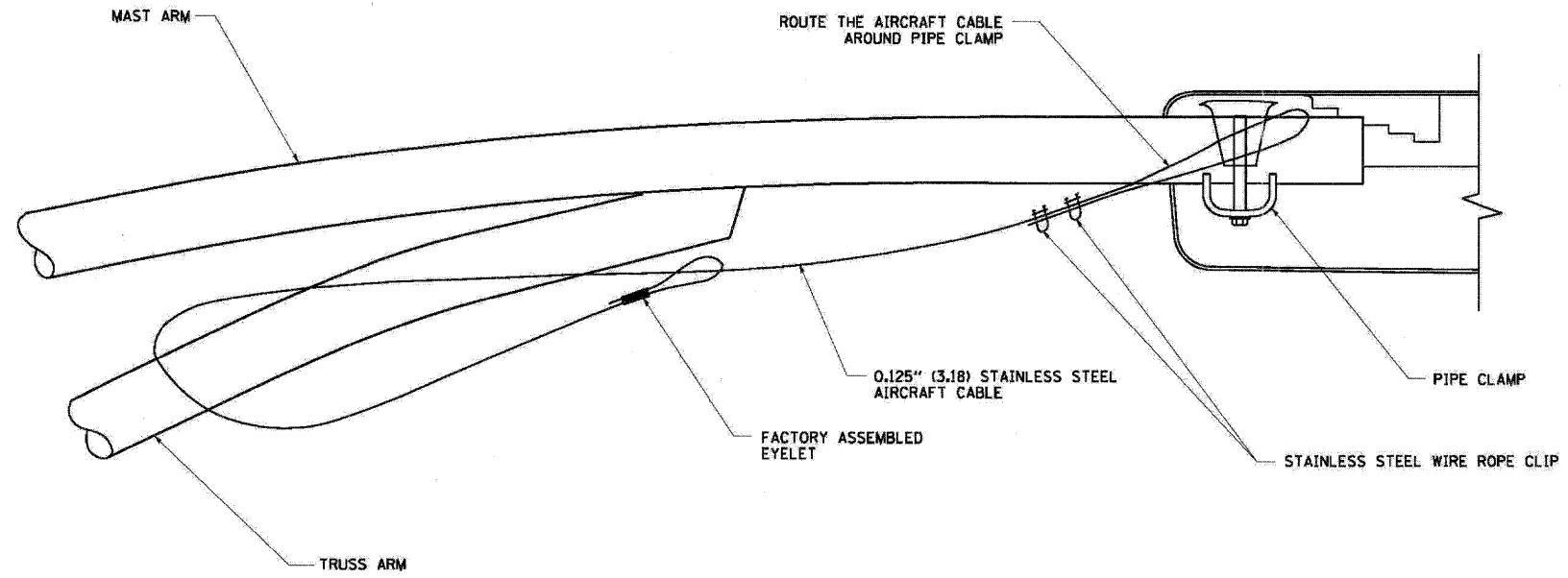

SIDE VIEW (TRUSS ARM)
N.T.S.

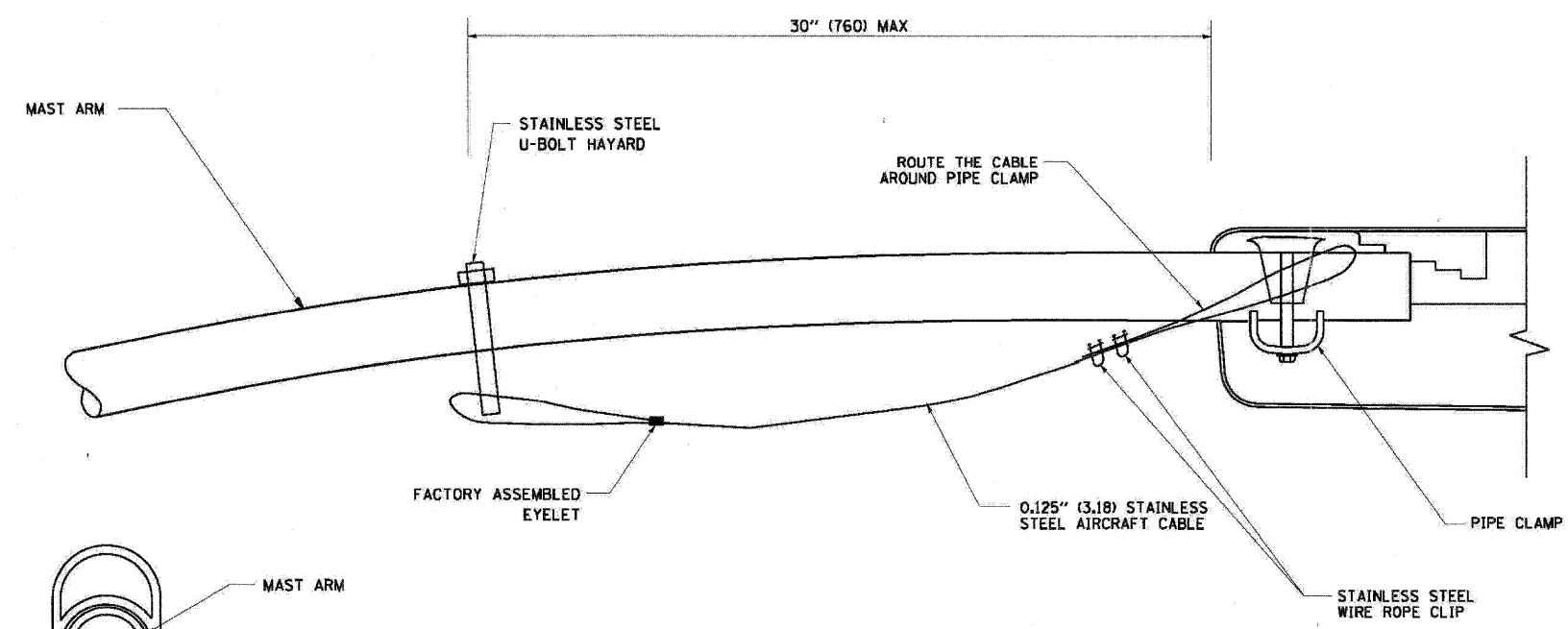

SIDE VIEW (SINGLE MEMBER OR DAVIT ARM)
N.T.S.

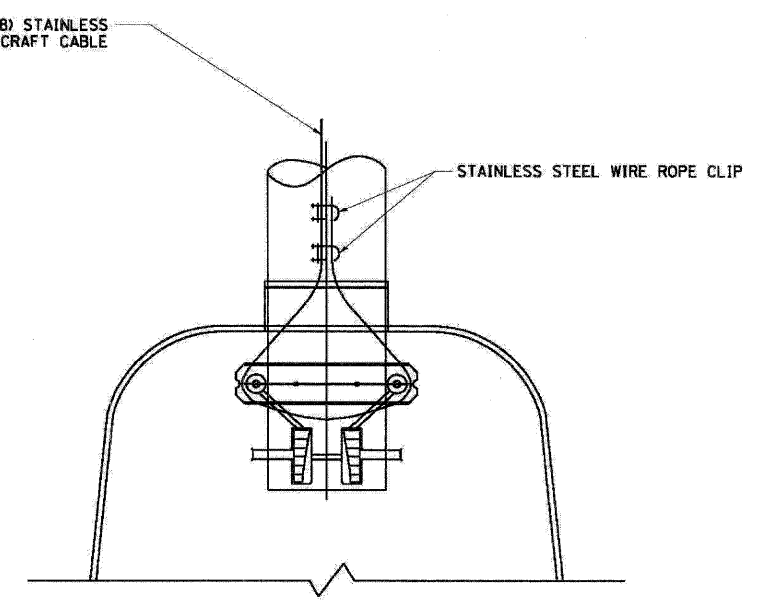

BOTTOM VIEW
N.T.S.

- NOTES:**
1. ALL DIMENSIONS ARE IN MILLIMETERS (INCHES) UNLESS OTHERWISE SHOWN.
 2. CONTRACTOR SHALL ADJUST THE WIRE CLIP TO ELIMINATE ANY SLACK FROM THE WIRE ROPE.
 3. THE 0.125" (3.18) STAINLESS STEEL AIRCRAFT CABLE SHALL REMAIN VISIBLE FROM THE GROUND LEVEL.
 4. THE BREAKING STRENGTH OF THE CABLE SHALL BE 1700 LBS. MIN.

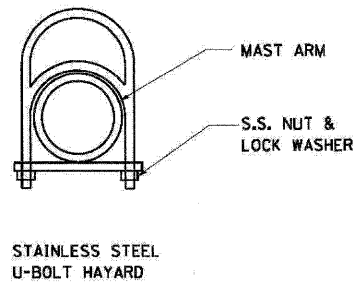

FILE NAME = w:\dist\beta\22x34\ba721.dgn	USER NAME = gglianab1	DESIGNED -	REVISED - 08-08-03	STATE OF ILLINOIS DEPARTMENT OF TRANSPORTATION	LUMINAIRE SAFETY CABLE ASSEMBLY			F.A. RTE.	SECTION	COUNTY	TOTAL SHEETS	SHEET NO.
		DRAWN -	REVISED -		SCALE: NONE	SHEET NO. 1 OF 1 SHEETS	STA.	TO STA.	04-00092-00-BR	KANE	440	425
		CHECKED -	REVISED -					BE-701		CONTRACT NO. 63650		
		DATE = 1/4/2008	REVISED -		FED. ROAD DIST. NO. 1 ILLINOIS FED. AID PROJECT							

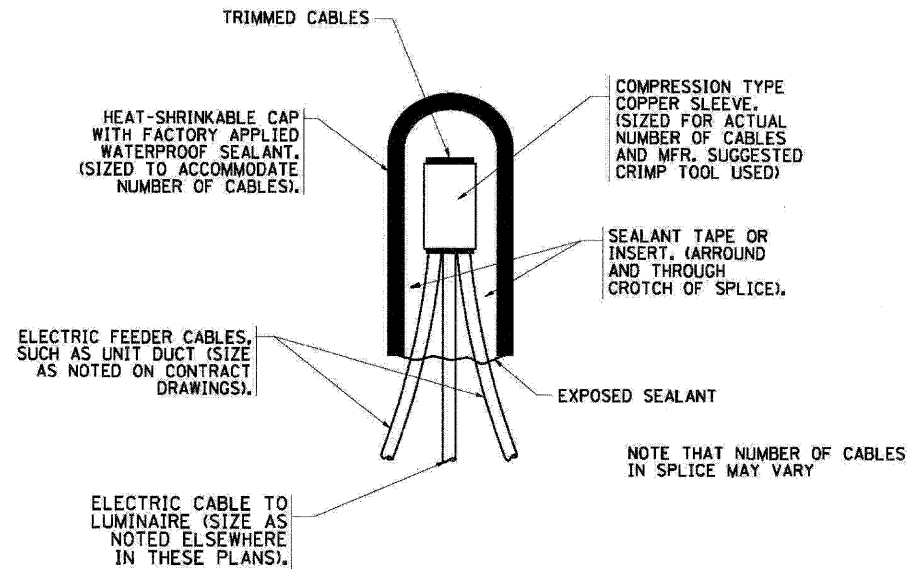

TYPICAL SPLICE DETAIL

N.T.S.

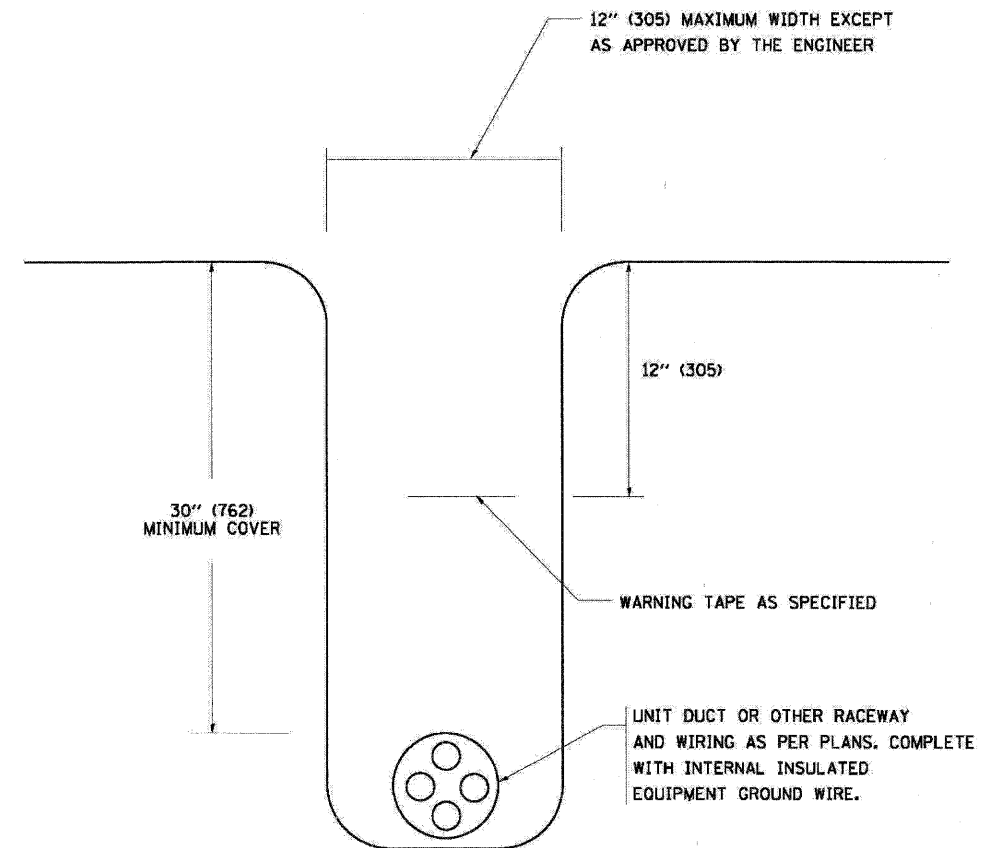

TYPICAL WIRING IN TRENCH DETAIL

N.T.S.

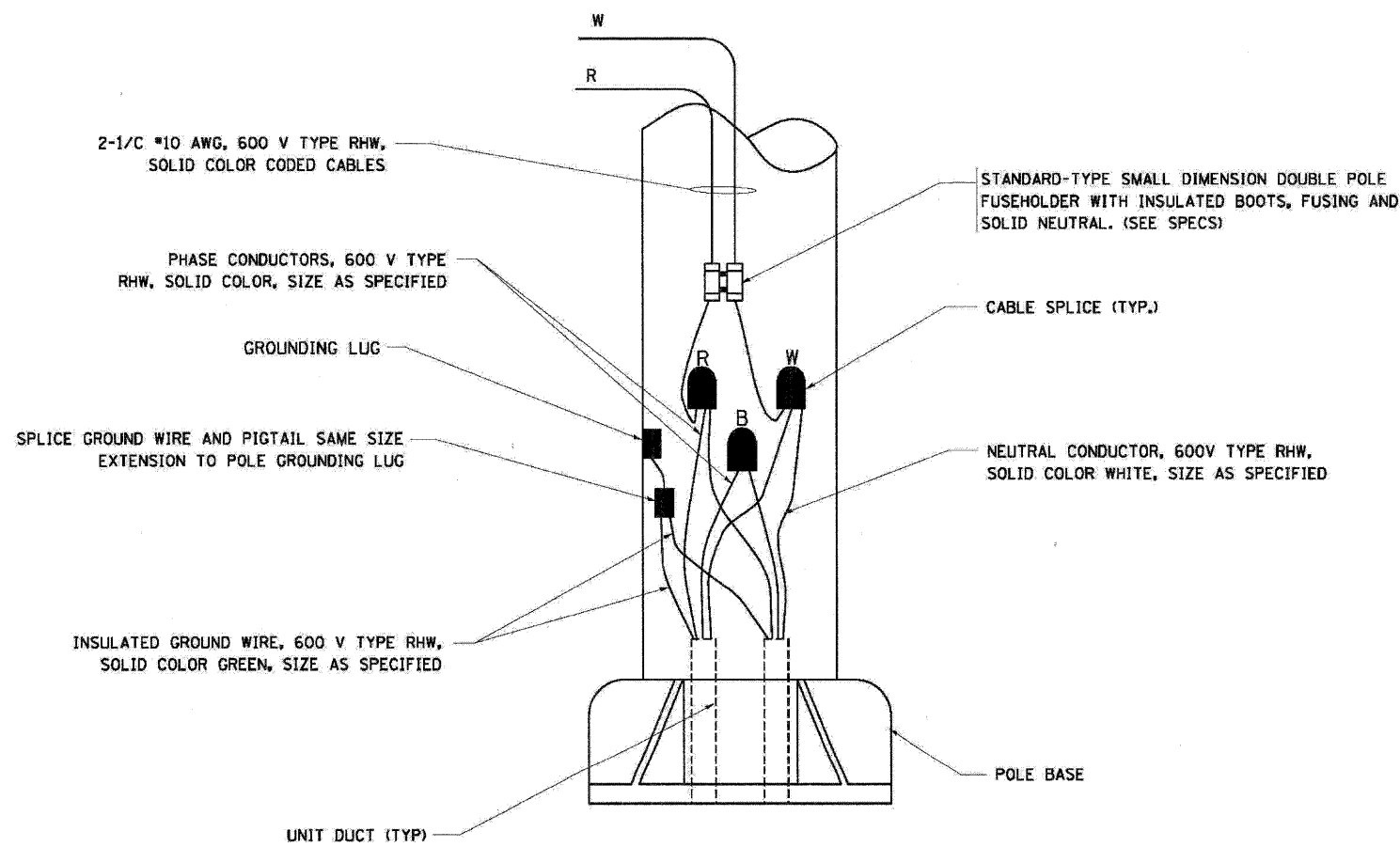

POLE WIRING DETAIL

N.T.S.

FILE NAME = W:\disto\22x34\ba702.dgn	USER NAME = gajlanob1	DESIGNED -	REVISED - 08-08-03	STATE OF ILLINOIS DEPARTMENT OF TRANSPORTATION	MISC. ELECTRICAL DETAILS SHEET A			F.A. RTE.	SECTION	COUNTY	TOTAL SHEETS	SHEET NO.	
		DRAWN -	REVISED -		SCALE: NONE	SHEET NO. 1 OF 1 SHEETS	STA.	TO STA.	04-00092-00-BR	KANE	440	426	
		CHECKED -	REVISED -						BE-702				CONTRACT NO. 63650
		DATE -	REVISED -						FED. ROAD DIST. NO. 1 ILLINOIS FED. AID PROJECT				

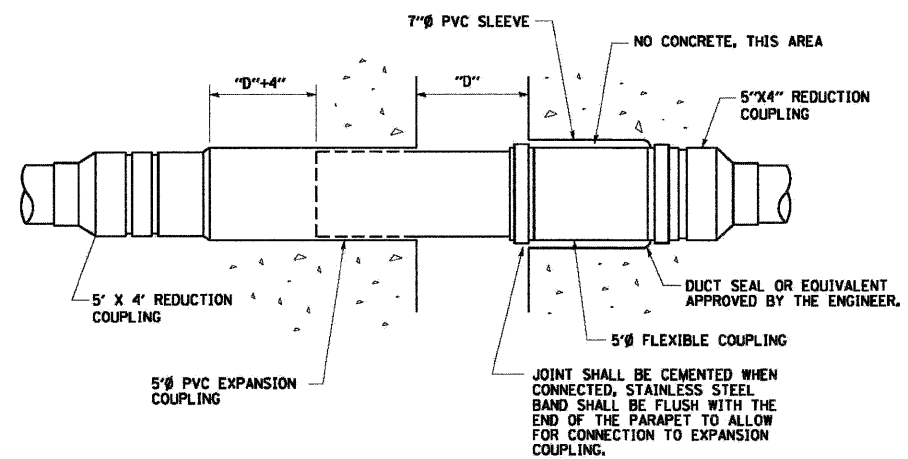

**INSTALLATION OF CONDUIT
 IN BRIDGE PARAPET EXPANSION JOINT**
 (N.T.S.)

FILE NAME = be703.dgn	USER NAME = gaglianobt	DESIGNED -	REVISED -	STATE OF ILLINOIS DEPARTMENT OF TRANSPORTATION	MISCELLANEOUS ELECTRICAL DETAILS, SHEET B J BOX EMBEDDED IN BARRIER WALL - INSTALLATION OF CONDUIT IN BRIDGE PARAPET EXPANSION JOINT - ELECTRIC CONNECTION TO UNDERPASS LIGHTING			F.A. -	SECTION	COUNTY	TOTAL	SHEET
	PLDT SCALE = 50.0000' / IN.	DRAWN -	REVISED -		RTE.	04-00092-00-BR	KANE	SHEETS	NO.			
PLDT DATE = 2/5/2009	CHECKED -	REVISED -	SCALE: NONE		SHEET NO. 1 OF 1 SHEETS	STA.	TO STA.	CONTRACT NO.	63650			
DATE - 01-20-2009	REVISED -	REVISED -				FED. ROAD DIST. NO. 1 ILLINOIS FED. AID PROJECT						

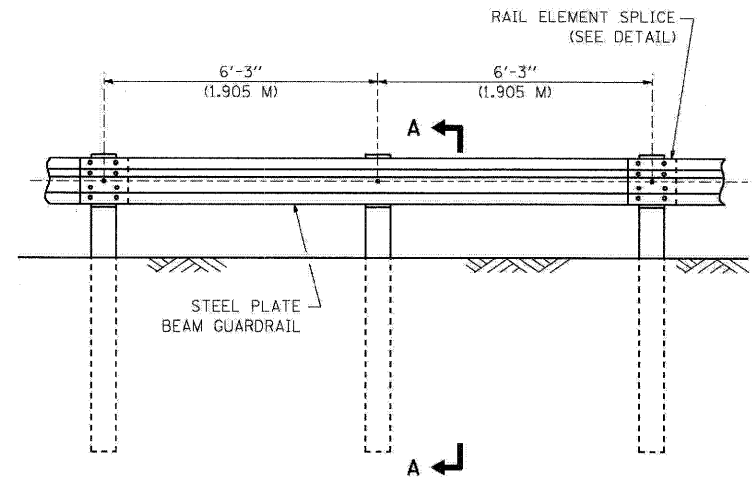

ELEVATION

TYPE A

6'-3" (1.905 M) TYPICAL POST SPACING

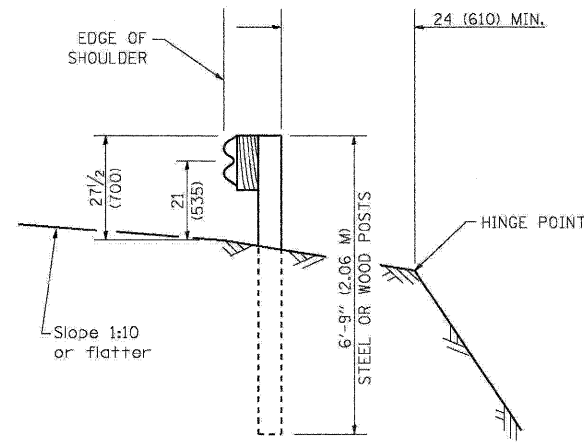

SECTION A-A

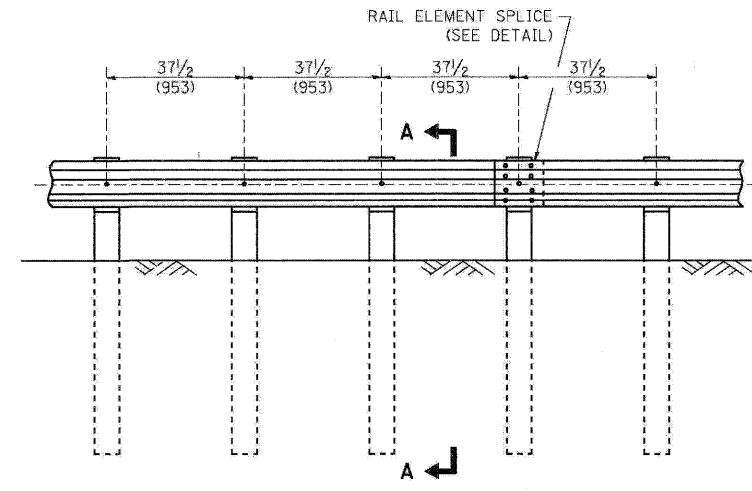

ELEVATION

TYPE A

37 1/2 (953) CLOSED POST SPACING

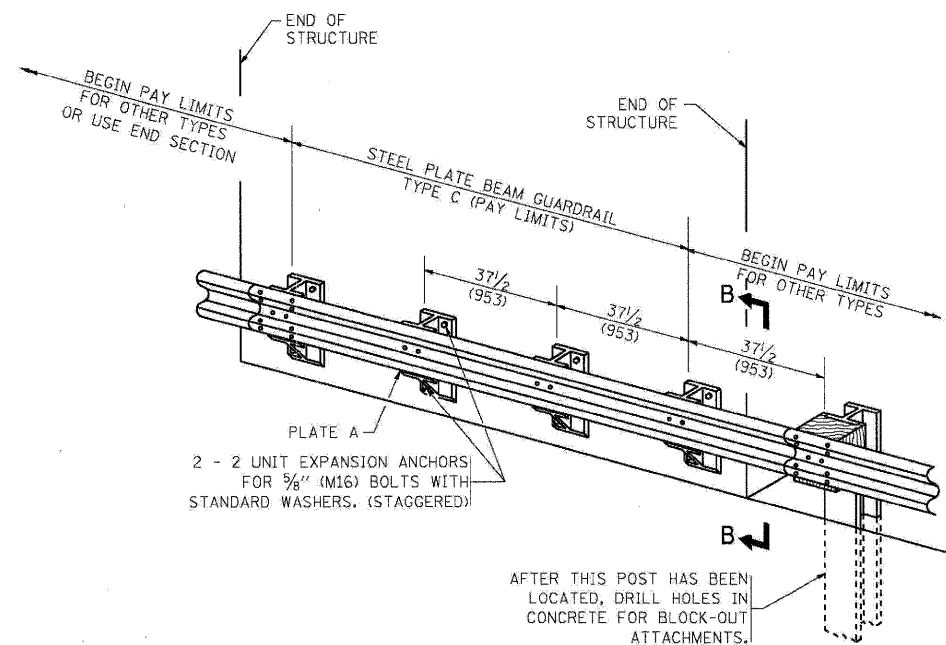

TYPE C

37 1/2 (953) BLOCK-OUT SPACING

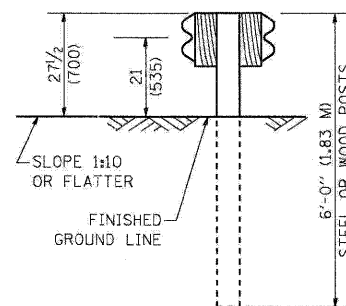

SECTION C-C

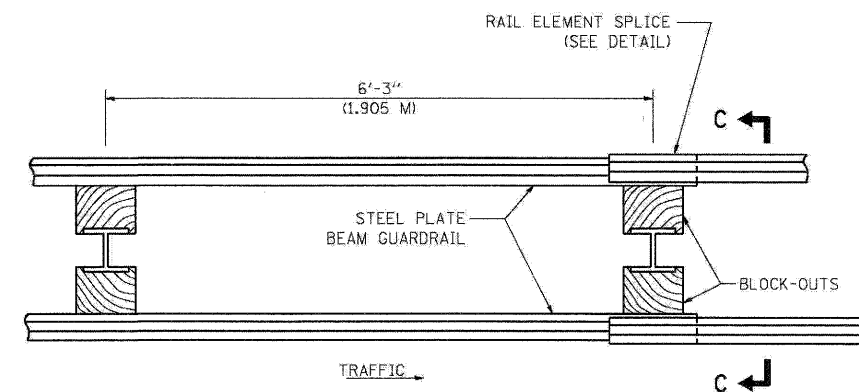

PLAN

TYPE D

DOUBLE STEEL PLATE BEAM GUARDRAIL
6'-3" (1.905 M) TYPICAL POST SPACING

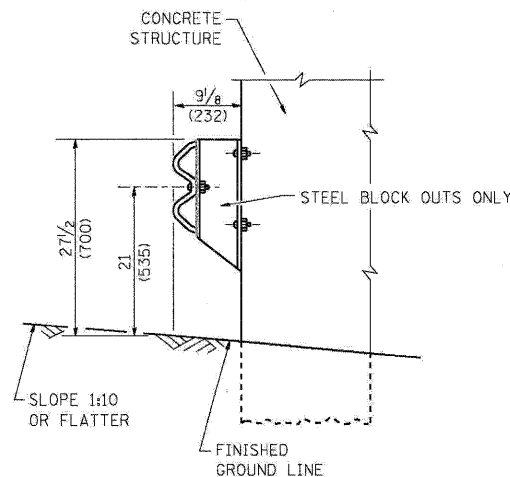

SECTION B-B

GENERAL NOTES

ALL SLOPE RATIOS ARE EXPRESSED AS UNITS OF VERTICAL DISPLACEMENT TO UNITS OF HORIZONTAL DISPLACEMENT (V:H).

ALL DIMENSIONS ARE IN INCHES (MILLIMETERS) UNLESS OTHERWISE SHOWN.

THE EXISTING STEEL POSTS MAY BE DRILLED TO MATCH THE BOLT PATTERN SHOWN HEREIN FOR THE WOOD BLOCK-OUT, OR A NEW STEEL POST SHALL BE PROVIDED.

THIS DETAIL IS APPLICABLE TO THE GUARDRAIL SYSTEM USED PRIOR TO JANUARY 1, 2007. FOR DETAILS ON THE MIDWEST GUARDRAIL SYSTEM, SEE STANDARD 630001.

FILE NAME = W:\diststd\22x34\bm21.dgn

USER NAME = gaglionobt
PLOT SCALE = 50.0000' / IN.
PLOT DATE = 1/4/2008

DESIGNED -
DRAWN -
CHECKED -
DATE -

REVISED - 10-31-06
REVISED -
REVISED -
REVISED -

**STATE OF ILLINOIS
DEPARTMENT OF TRANSPORTATION**

**REMOVE AND REERECT
STEEL PLATE BEAM GUARDRAIL**

SCALE: NONE SHEET NO. 1 OF 4 SHEETS STA. TO STA.

F.A. RTE.	SECTION	COUNTY	TOTAL SHEETS	SHEET NO.
	04-00092-00-BR	KANE	440	428
	BM-21			CONTRACT NO. 63650
FED. ROAD DIST. NO. 1 ILLINOIS FED. AID PROJECT				

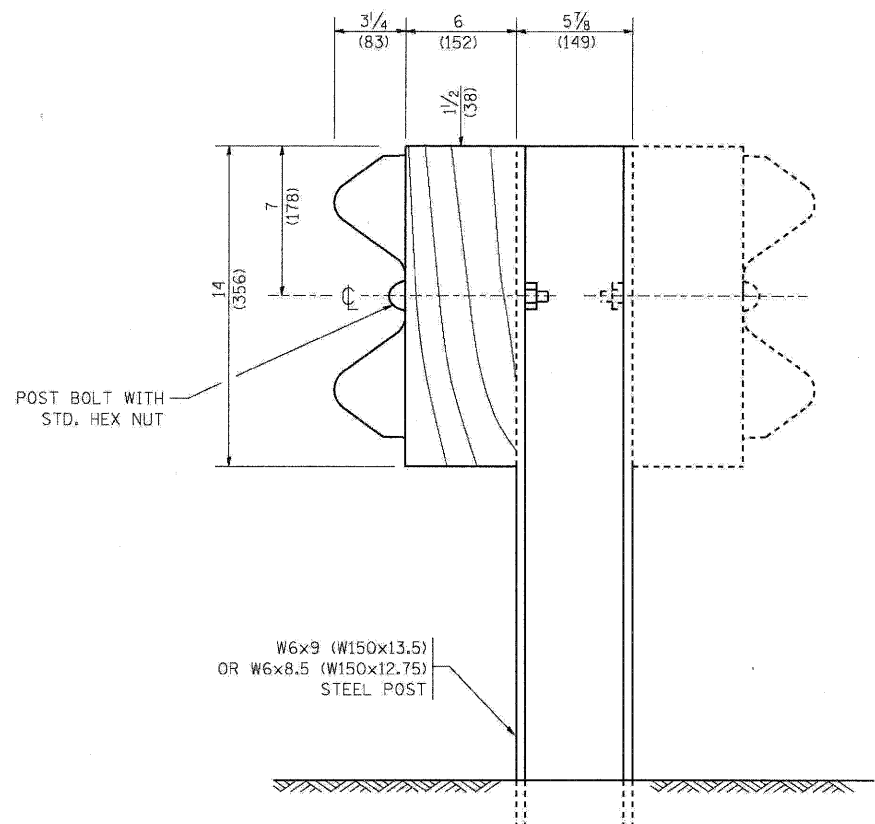

STEEL POST CONSTRUCTION

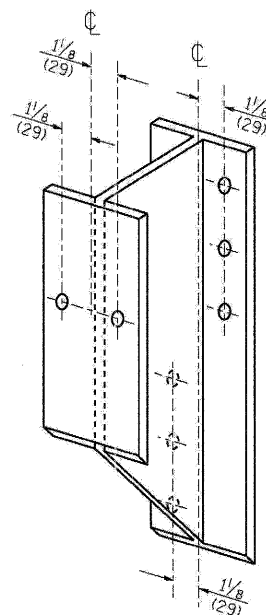

STEEL BLOCK-OUT DETAIL

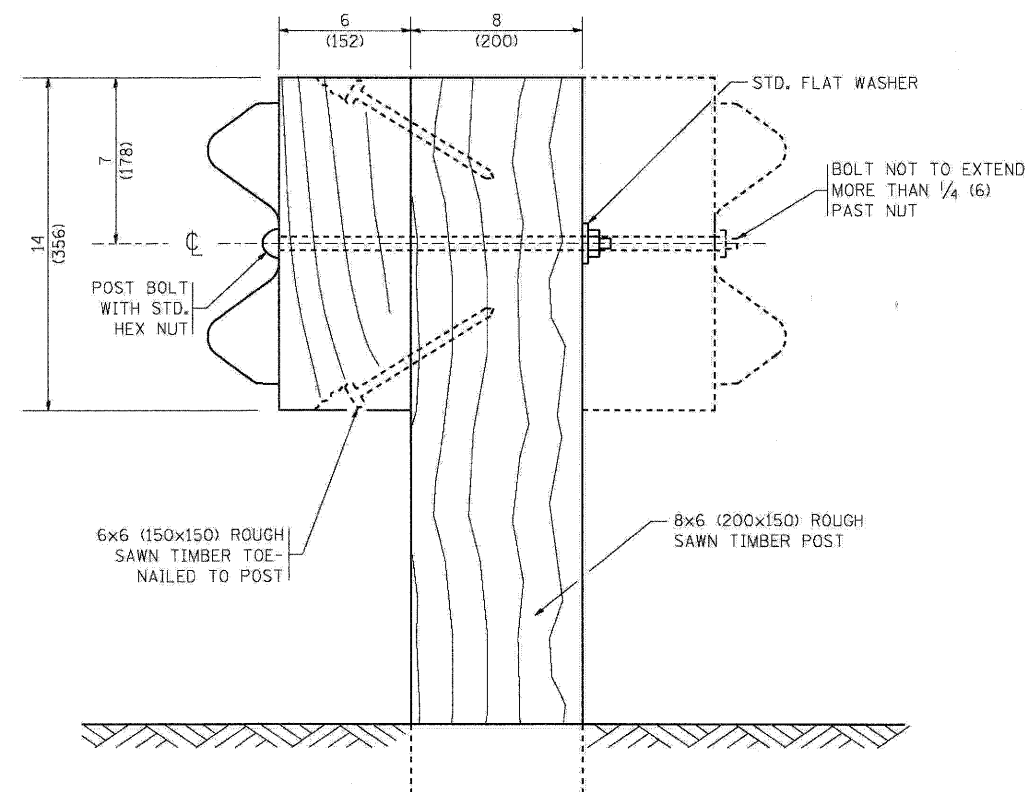

WOOD POST CONSTRUCTION

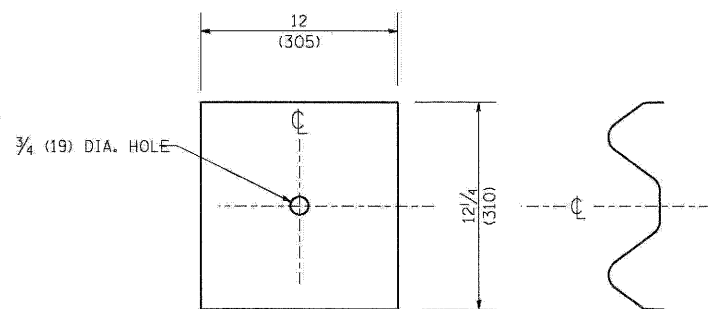

NOTE:

PLATE A SHALL BE PLACED BETWEEN RAIL ELEMENT AND BLOCK-OUT AT NON-SPLICE MOUNTING POINTS ONLY WHEN STEEL BLOCK-OUTS ARE USED.

PLATE A

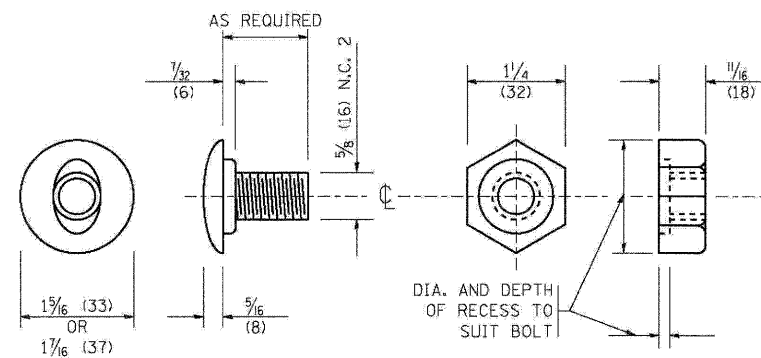

POST OR SPLICE BOLT & NUT

FILE NAME =
W:\diststd\22x34\bm21.dgn

USER NAME = geglianobt
PLOT SCALE = 50.0000' / IN.
PLOT DATE = 1/4/2008

DESIGNED -
DRAWN -
CHECKED -
DATE -

REVISED - 10-31-06
REVISED -
REVISED -
REVISED -

**STATE OF ILLINOIS
DEPARTMENT OF TRANSPORTATION**

**REMOVE AND REERECT
STEEL PLATE BEAM GUARDRAIL**

SCALE: NONE SHEET NO. 2 OF 4 SHEETS STA. TO STA.

F.A. RTE.	SECTION	COUNTY	TOTAL SHEETS	SHEET NO.
	04-00092-00-BR	KANE	440	429
BM-21			CONTRACT NO. 63650	
FED. ROAD DIST. NO. 1 ILLINOIS FED. AID PROJECT				

PLACE STANDARD END SHOE BETWEEN SPLICE PLATE AND RAIL ELEMENT

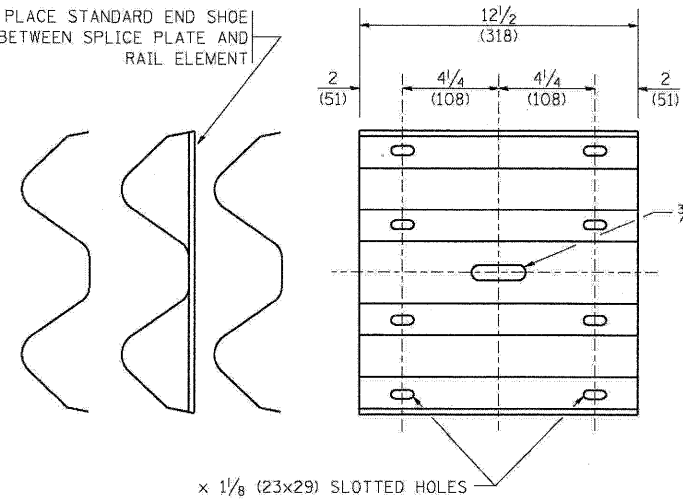

SPLICE PLATE

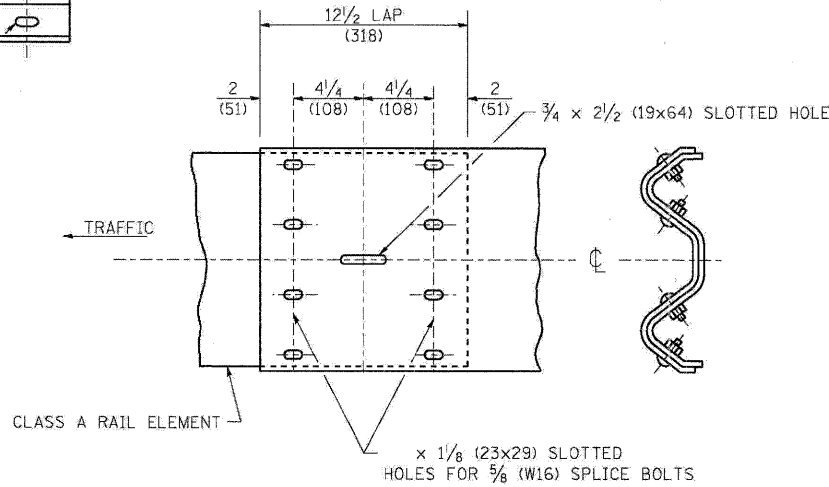

RAIL ELEMENT SPLICE

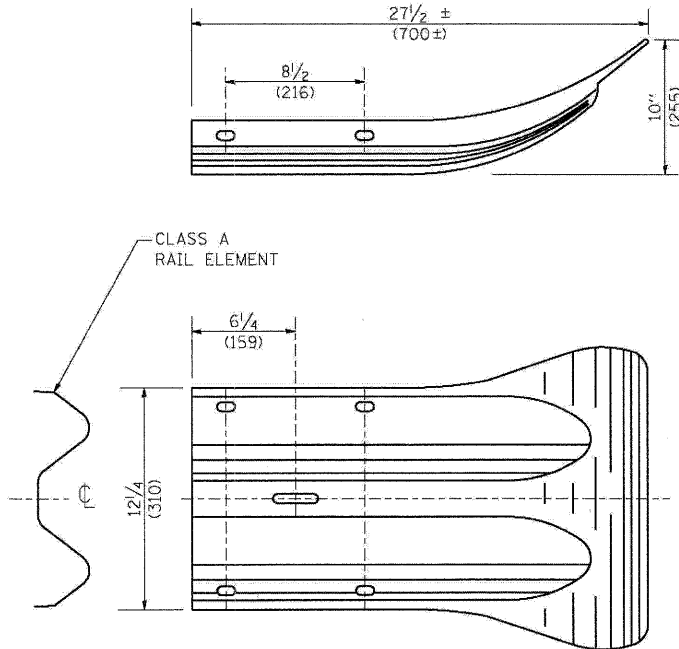

END SECTION

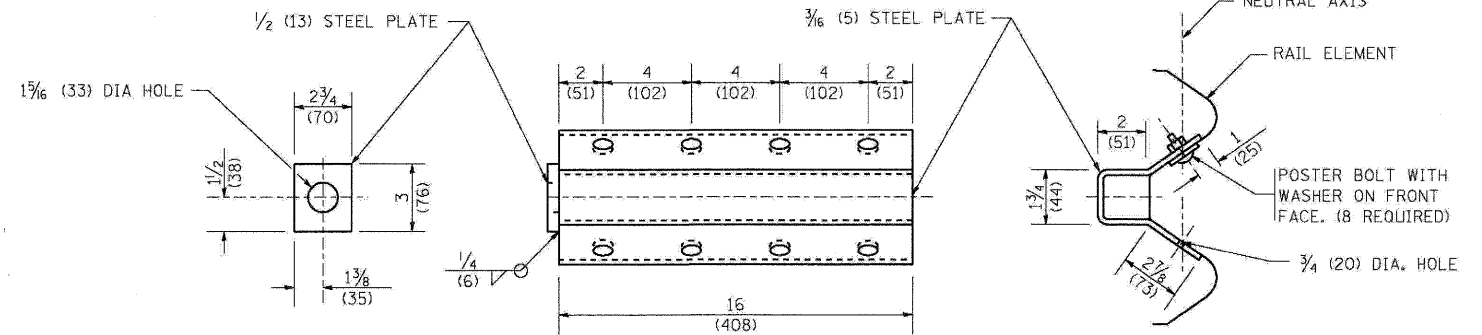

NOTE:

ANCHOR PLATE T SHALL BE USED TO ATTACH CABLE ASSEMBLY TO GUARDRAIL WHEN REQUIRED ON TRAFFIC BARRIER TERMINALS.

ANCHORE PLATE T DETAILS

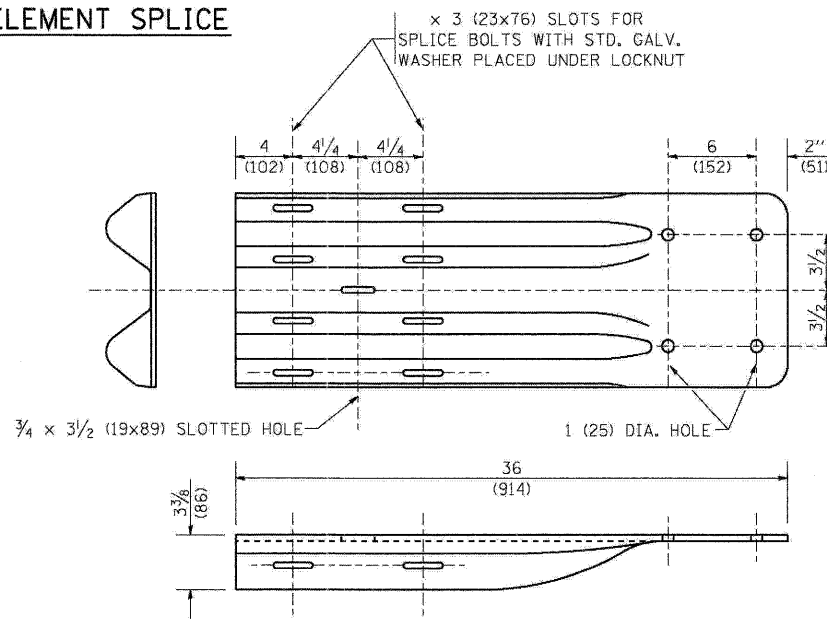

END SHOE

NOTE:

WHEN END SHOE IS ATTACHED TO A BRIDGE PARAPET WHICH HAS AN EXPANSION JOINT, THE BOLTS SHALL BE PROVIDED WITH A LOCKNUT OR DOUBLE NUT AND SHALL BE TIGHTENED ONLY TO A POINT THAT WILL ALLOW GUARDRAIL MOVEMENT.

THE STANDARD END SHOE SHALL BE ATTACHED TO THE CONCRETE WITH PRE-DRILLED OR SELF-DRILLING ANCHOR BOLTS. THE ANCHOR CONE SHALL BE SET FLUSH WITH THE SURFACE OF THE CONCRETE.

EXTERNALLY THREADED STUDS PROTRUDING FROM THE SURFACE OF THE CONCRETE WILL NOT BE PERMITTED.

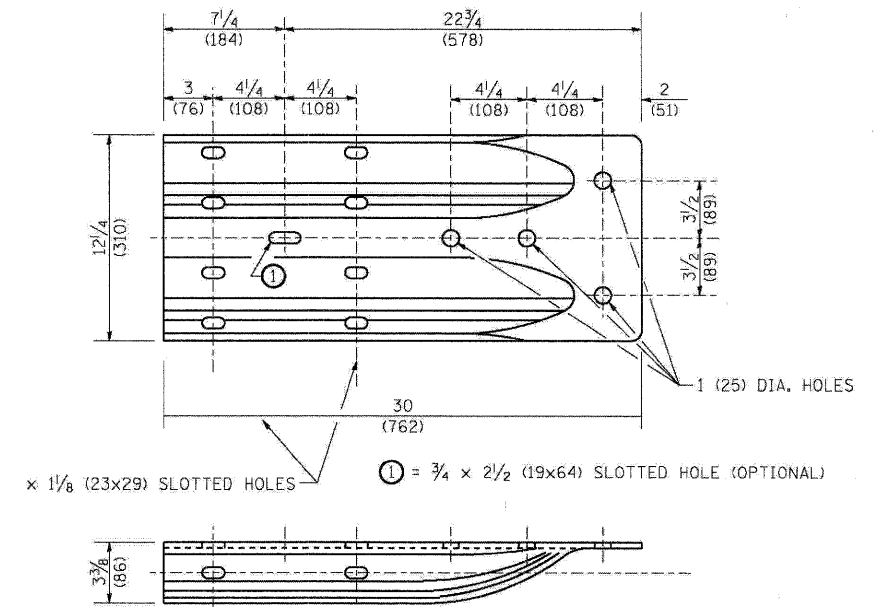

ALTERNATE END SHOE

FILE NAME = W:\diststd\22x34\bm21.dgn

USER NAME = geglienobt

DESIGNED - REVISED - 10-31-06

DRAWN - REVISED -

PLOT SCALE = 50,0000' / IN.

CHECKED - REVISED -

PLOT DATE = 1/4/2008

DATE - REVISED -

**STATE OF ILLINOIS
DEPARTMENT OF TRANSPORTATION**

**REMOVE AND REERECT
STEEL PLATE BEAM GUARDRAIL**

SCALE: NONE SHEET NO. 3 OF 4 SHEETS STA. TO STA.

F.A. RTE.	SECTION	COUNTY	TOTAL SHEETS	SHEET NO.
	04-00092-00-BR	KANE	440	430
	BM-21		CONTRACT NO. 63650	
FED. ROAD DIST. NO. 1 ILLINOIS FED. AID PROJECT				

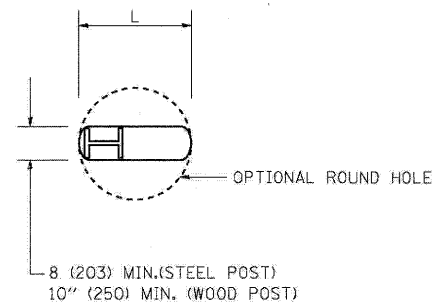

PLAN

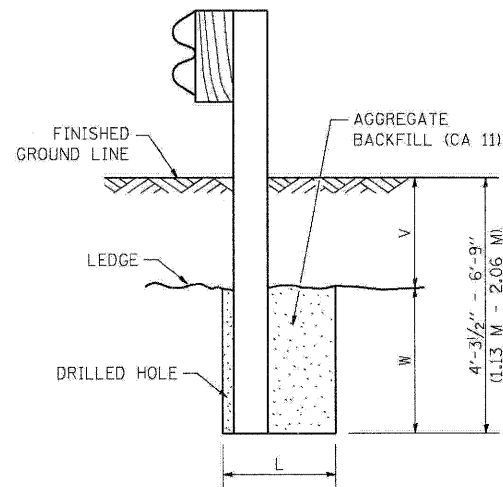

NOTE:
LEDGE LINE IS TOP OF ROCK
LEDGE OR HARD SLAG FILL.

ELEVATION

FOOTING FOR POST WHEN IMPERVIOUS
MATERIAL IS ENCOUNTERED

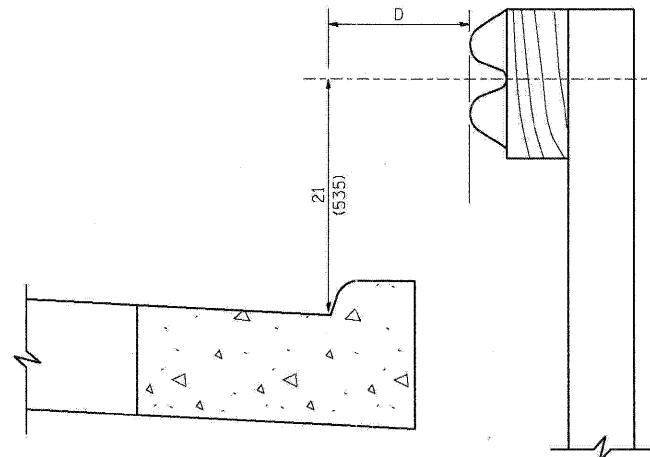

NOTE:

IF IT IS NECESSARY FOR D TO BE MORE THAN 12 (300) AND LESS THAN 10'-0" (3.0 M) TYPE M-2 (M-5) CURB AND GUTTER (STD. 606001) SHALL BE USED IN FRONT OF AND IN ADVANCE OF THE GUARDRAIL.

GUARDRAIL PLACED BEHIND CURB

(D = 0 DESIRABLE TO 12 (300) MAXIMUM)

V	W	L	
		STEEL POST	WOOD POST
0 - 18 (0 - 460)	24 (610)	21 (530)	23 (580)
>18 - 41.5 (> 460 - 825)	12 (305)	8 (203)	10 (250)
>41.5 - 53.5 (> 825 - 1.13 M)	12 - 0 (350 - 0)	8 (203)	10 (250)

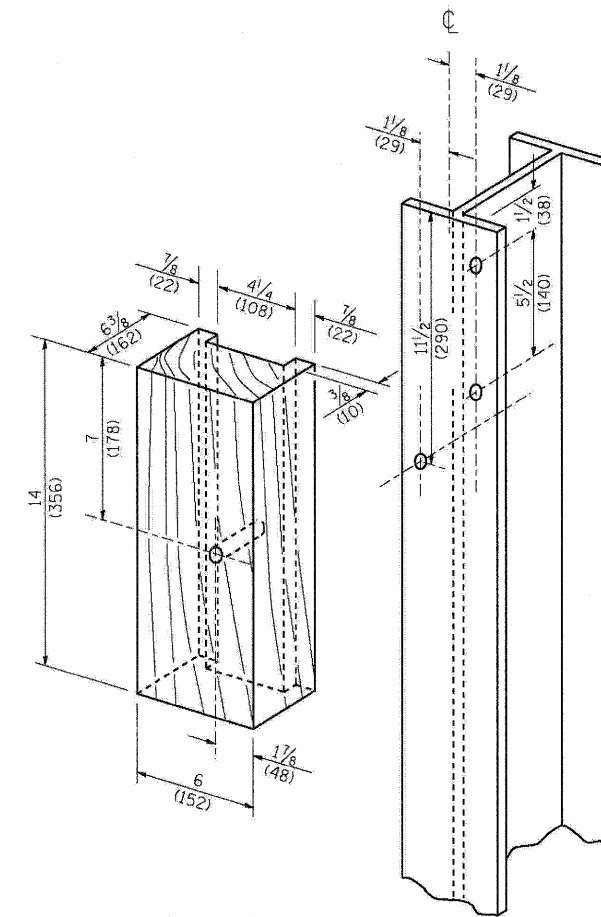

WOOD BLOCK-OUT AND
STEEL POST DETAILS

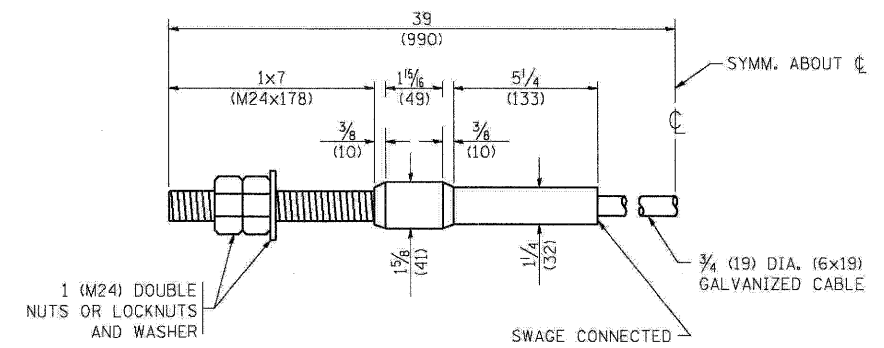

CABLE ASSEMBLY

(40,000 LBS (18,100 KG) MIN. BREAKING STRENGTH)
TIGHTEN TO TAUT TENSION

FILE NAME =
W:\d\ststd\22x34\bm21.dgn

USER NAME = geglianobt

DESIGNED -
DRAWN -

REVISED - 10-31-06

PLOT SCALE = 50.0000' / IN.

CHECKED -
DATE -

PLOT DATE = 1/4/2008

REVISED -

STATE OF ILLINOIS
DEPARTMENT OF TRANSPORTATION

REMOVE AND REERECT
STEEL PLATE BEAM GUARDRAIL

SCALE: NONE SHEET NO. 4 OF 4 SHEETS STA. TO STA.

F.A. RTE.	SECTION	COUNTY	TOTAL SHEETS	SHEET NO.
	04-00092-00-BR	KANE	440	431
	BM-21			CONTRACT NO. 63650

FED. ROAD DIST. NO. 1 ILLINOIS FED. AID PROJECT

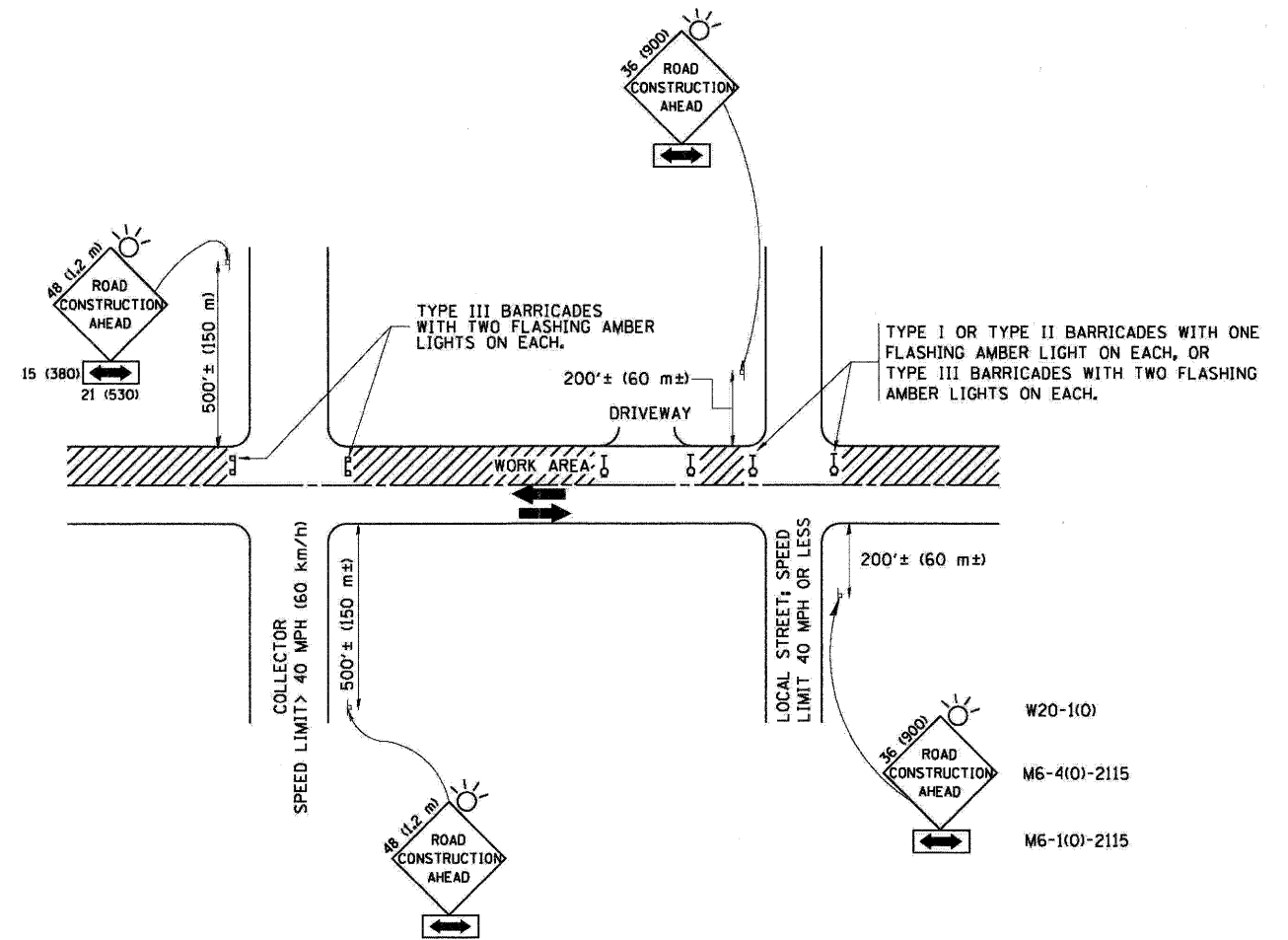

TRAFFIC CONTROL AND PROTECTION FOR SIDE ROADS, INTERSECTIONS, AND DRIVEWAYS

NOTES:

A. FOR NO LANE RESTRICTION ON THE SIDE ROAD OR DRIVEWAYS

1. SIDE ROAD WITH A SPEED LIMIT OF 40 MPH (60 km/h) OR LESS AS SHOWN ON THE DRAWING AND AS DIRECTED BY THE ENGINEER:
 - a) ONE ROAD CONSTRUCTION AHEAD SIGN 36 x 36 (900x900) WITH A FLASHER AND FLAG MOUNTED ON IT APPROXIMATELY 200' (60 m) IN ADVANCE OF THE MAIN ROUTE.
 - b) THE CLOSED PORTION OF THE MAIN ROUTE SHALL BE PROTECTED BY BLOCKING WITH TYPE I, TYPE II OR TYPE III BARRICADES, 1/3 OF THE CROSS SECTION OF THE CLOSED PORTION.
2. SIDE ROAD WITH A SPEED LIMIT GREATER THAN 40 MPH (60 km/h) AS SHOWN ON THE DRAWING AND AS DIRECTED BY THE ENGINEER:
 - a) ONE ROAD CONSTRUCTION AHEAD SIGN 48 x 48 (1.2 m x 1.2 m) WITH A FLASHER MOUNTED ON IT APPROXIMATELY 500' (150 m) IN ADVANCE OF THE MAIN ROUTE.
 - b) THE CLOSED PORTION OF THE MAIN ROUTE SHALL BE PROTECTED BY BLOCKING WITH TYPE III BARRICADES, 1/2 OF THE CROSS SECTION OF THE CLOSED PORTION.
3. WHEN THE SIDE ROAD LIES BETWEEN THE BEGINNING OF THE MAINLINE SIGNING AND THE WORK ZONE, A SINGLE HEADED ARROW (M6-1) SHALL BE USED IN LIEU OF THE DOUBLE HEADED ARROW (M6-4).

B. FOR A LANE CLOSURE ON A SIDE ROAD OR DRIVEWAY:

USE APPLICABLE PORTIONS OF THE TYPICAL APPLICATION OF TRAFFIC CONTROL DEVICES (STD. 701501, STD. 701606 OR THE APPROPRIATE STANDARD). THE SPACING OF SIGNS AND BARRICADES SHALL BE ADJUSTED FOR FIELD CONDITIONS AS DIRECTED BY THE ENGINEER. THE DIRECTIONAL ARROW SHALL BE COVERED OR REMOVED WHEN NO LONGER CONSISTENT WITH THE SIDE ROAD LANE CLOSURE.

C. ADVANCE WARNING SIGNS ARE TO BE OMITTED ON DRIVEWAY UNLESS OTHERWISE NOTED.

D. THE TRAFFIC CONTROL AND PROTECTION FOR SIDE ROADS, INTERSECTIONS, AND DRIVEWAYS SHALL BE INCIDENTAL TO THE COST OF SPECIFIED TRAFFIC CONTROL STANDARDS OR ITEMS.

All dimensions are in millimeters (inches) unless otherwise shown.

FILE NAME = W:\dstatd\22x34\tbl.dgn	USER NAME = geglinoht	DESIGNED - LHA	REVISED - J. OBERLE 10-18-95
		DRAWN -	REVISED - A. HOUSEH 03-06-96
	PLOT SCALE = 50,000 / IN.	CHECKED -	REVISED - A. HOUSEH 10-15-96
	PLOT DATE = 1/4/2008	DATE - 06-89	REVISED - T. RAMMACHER 01-06-00

**STATE OF ILLINOIS
DEPARTMENT OF TRANSPORTATION**

**TRAFFIC CONTROL AND PROTECTION FOR
SIDE ROADS, INTERSECTIONS, AND DRIVEWAYS**

SCALE: NONE SHEET NO. 1 OF 1 SHEETS STA. TO STA.

F.A. RTE.	SECTION	COUNTY	TOTAL SHEETS	SHEET NO.
	04-00092-00-BR	KANE	440	432
TC-10			CONTRACT NO. 63650	
FED. ROAD DIST. NO. 1 ILLINOIS FED. AID PROJECT				

CONTRACT NO. 63650			
F.A. RTE.	SECTION	COUNTY	TOTAL SHEETS
*	*	KANE	440
SHEET NO.		433	
STA.		TO STA.	
FED. ROAD DIST. NO.		ILLINOIS FED. AID PROJECT	
* 04-00092-00-BR			

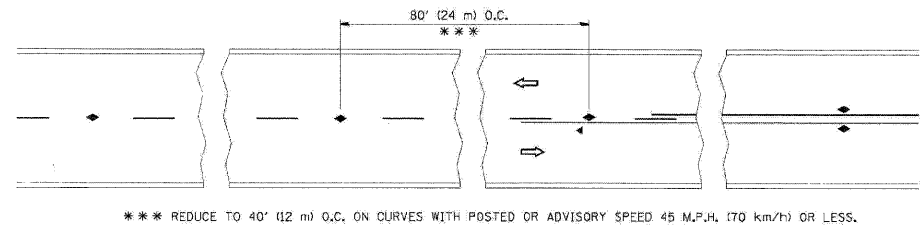

TWO-LANE/TWO-WAY

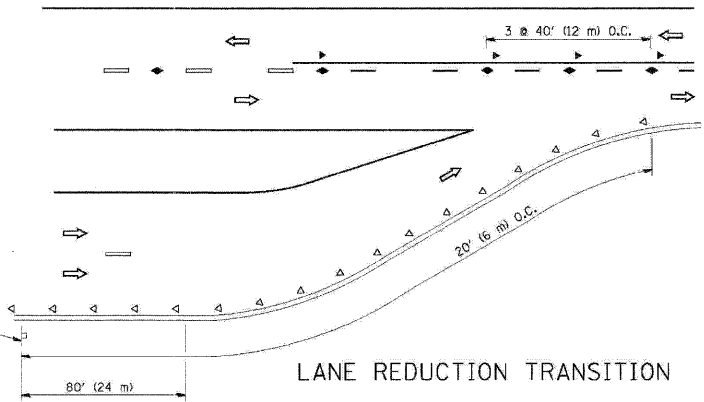

LANE REDUCTION TRANSITION

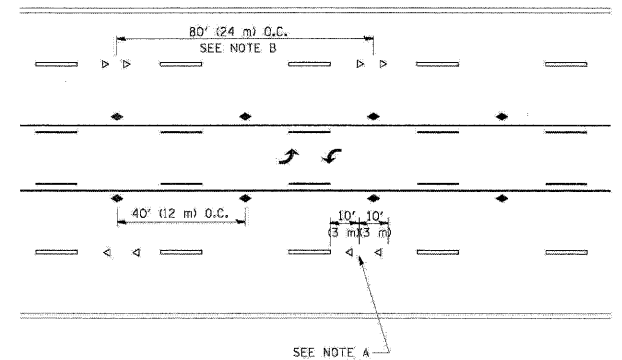

TWO-WAY LEFT TURN

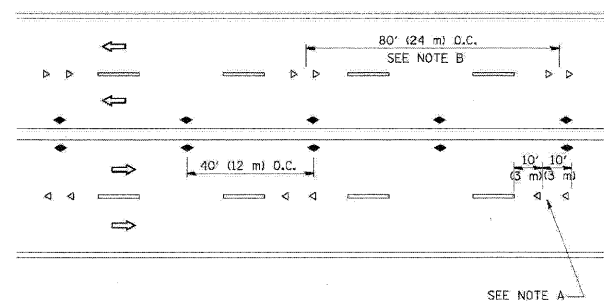

MULTI-LANE/UNDIVIDED

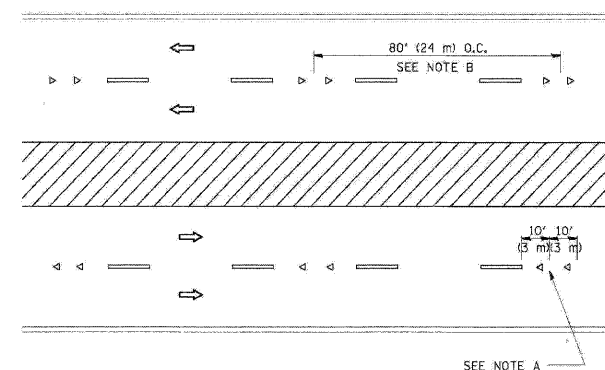

MULTI-LANE/DIVIDED

GENERAL NOTES

1. MARKERS USED WITH DASHED LINES SHALL BE CENTERED IN THE GAP BETWEEN SEGMENTS.
2. MARKERS USED ADJACENT TO SOLID LINES SHALL BE OFFSET 2 TO 3 (50 TO 75) TOWARD TRAFFIC AS SHOWN.
3. MARKERS THROUGH TANGENTS LESS THAN 500' (150 m) IN LENGTH BETWEEN CURVES SHALL BE INSTALLED AT THE LESSER OF THE TWO CURVE SPACINGS.

SYMBOLS

- YELLOW STRIPE
- WHITE STRIPE
- ◀ ONE-WAY AMBER MARKER
- ◄ ONE-WAY CRYSTAL MARKER (W/O)
- ◆ TWO-WAY AMBER MARKER

LANE MARKER NOTES

- A. USE DOUBLE LANE LINE MARKERS SPACED AS SHOWN.
- B. REDUCE TO 40' (12 m) O.C. ON CURVES WHERE ADVISORY SPEEDS ARE 10 M.P.H. (20 km/h) LOWER THAN POSTED SPEEDS.

DESIGN NOTES

1. DOUBLE LANE LINE MARKERS SHALL BE USED UNLESS SPECIFIED OTHERWISE.
2. EXCEPT AS SHOWN ON THE LANE REDUCTION TRANSITION AND FREEWAY EXIT RAMP DETAIL, MARKERS ARE NOT TO BE SPECIFIED ON RIGHT EDGE LINES.
3. THE EXACT MARKER LIMITS, SPACING, AND COLOR SHOULD BE INCLUDED IN THE PLANS.
4. MARKERS SHOULD NOT BE USED ALONGSIDE CURBS EXCEPT FOR EXTREMELY SHORT SECTIONS OF CURBS WHERE NOT MORE THAN TWO MARKERS WOULD BE INVOLVED.

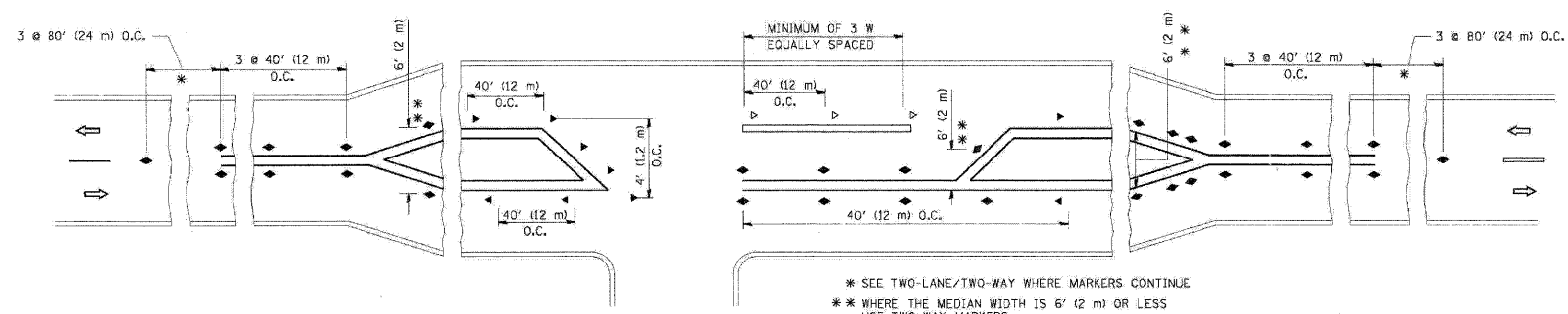

LEFT TURN

* SEE TWO-LANE/TWO-WAY WHERE MARKERS CONTINUE
 ** WHERE THE MEDIAN WIDTH IS 6' (2 m) OR LESS USE TWO-WAY MARKERS.

All dimensions are in inches (millimeters) unless otherwise shown.

REVISIONS	
NAME	DATE
T. RAMMACHER	09-19-94
T. RAMMACHER	03-12-99
T. RAMMACHER	01-06-00
C. JUCIUS	09-09-09

ILLINOIS DEPARTMENT OF TRANSPORTATION
 TYPICAL APPLICATIONS
 RAISED REFLECTIVE PAVEMENT
 MARKERS (SNOW-PLOW RESISTANT)

SCALE: NONE

DRAWN BY CADD
 CHECKED BY
 TC-11

PLOT DATE = 9/12/2009
 FILE NAME = 040092-00-BR-0433.dgn
 USER NAME = drvakcegn

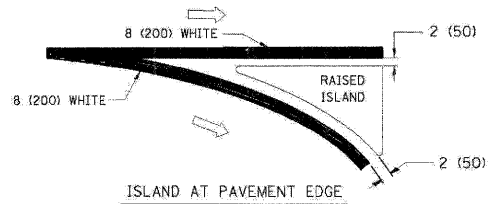
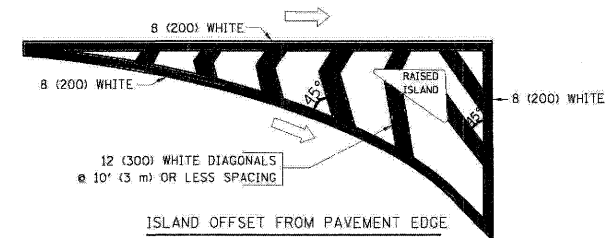
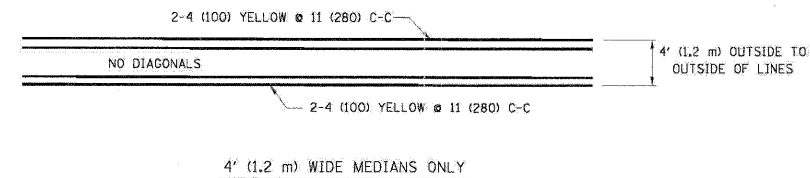
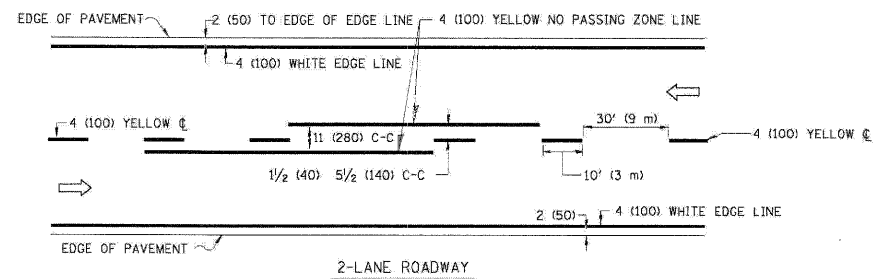

TYPICAL ISLAND MARKING

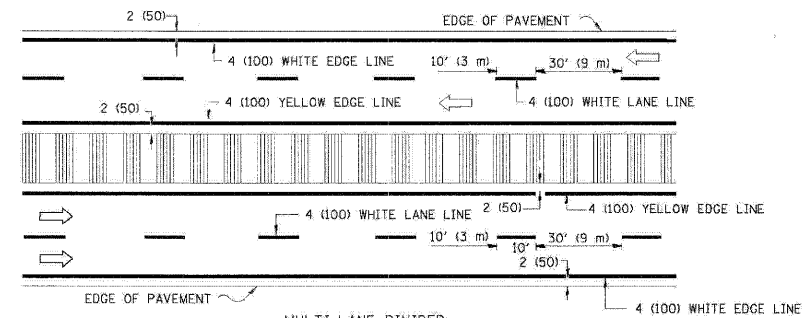
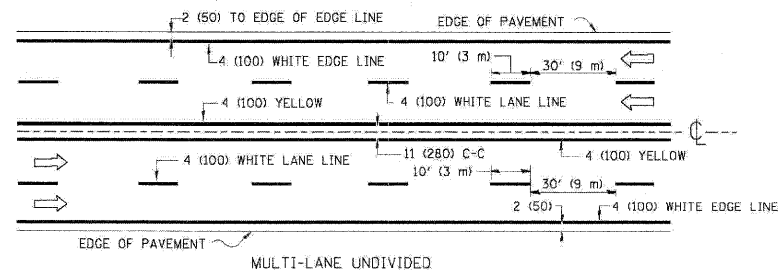

NOTE: MEDIANS WITH BARRIER CURB DO NOT REQUIRE AN EDGE LINE

TYPICAL LANE AND EDGE LINE MARKING

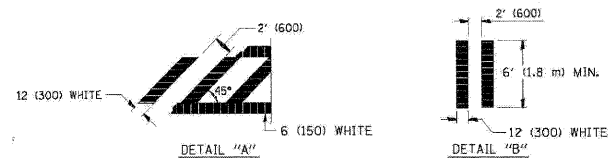
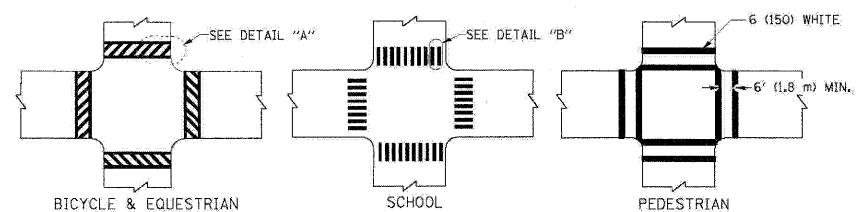

TYPICAL CROSSWALK MARKING

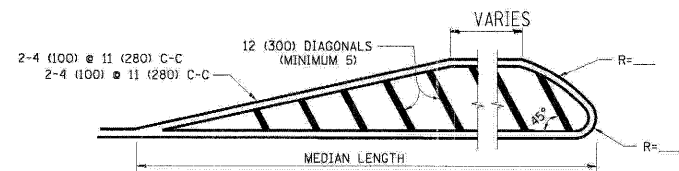

FOR MEDIAN LENGTHS WHERE DIAGONAL SPACING CANNOT BE ATTAINED, USE 5 (FIVE) EQUALLY SPACED DIAGONAL LINES.

DIAGONAL LINE SPACING: 50' (15 m) C-C (LESS THAN 30MPH (50 km/h))
75' (25 m) C-C 30MPH (50 km/h) TO 45MPH (70 km/h)
150' (45 m) C-C (MORE THAN 45MPH (70 km/h))

MEDIANS OVER 4' (1.2 m) WIDE

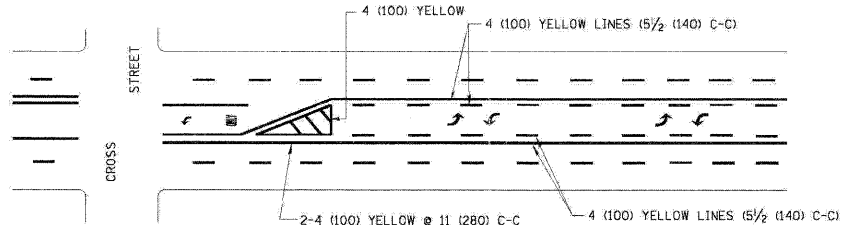

A MINIMUM OF TWO PAIRS OF TURN ARROWS SHALL BE USED, WHITE IN COLOR. ADDITIONAL PAIRS SHALL BE PLACED AT 200' (60 m) TO 300' (90 m) INTERVALS.

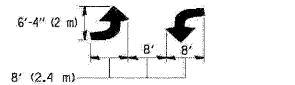

MEDIAN WITH TWO-WAY LEFT TURN LANE

TYPICAL PAINTED MEDIAN MARKING

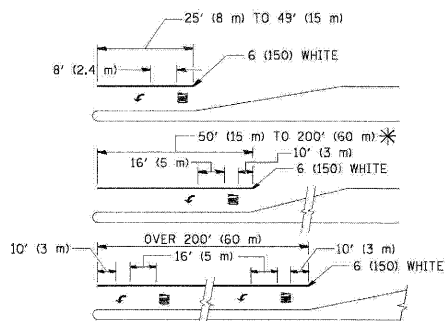

FULL SIZE LETTERS 8' (2.4 m) AND ARROWS SHALL BE USED. * AREA = 15.6 SQ. FT. (1.5 m²) ONLY AREA = 20.8 SQ. FT. (1.9 m²)

* TURN LANES IN EXCESS OF 400' (120 m) IN LENGTH MAY HAVE AN ADDITIONAL SET OF ARROW - "ONLY" INSTALLED MIDWAY BETWEEN THE OTHER TWO SETS OF ARROW - "ONLY".

TYPICAL LEFT (OR RIGHT) TURN LANE

TYPICAL TURN LANE MARKING

TYPE OF MARKING	WIDTH OF LINE	PATTERN	COLOR	SPACING / REMARKS
CENTERLINE ON 2 LANE PAVEMENT	4 (100)	SKIP-DASH	YELLOW	10' (3 m) LINE WITH 30' (9 m) SPACE
CENTERLINE ON MULTI-LANE UNDIVIDED PAVEMENT	2 @ 4 (100)	SOLID	YELLOW	11 (280) C-C
NO PASSING ZONE LINES: FOR ONE DIRECTION FOR BOTH DIRECTIONS	4 (100) 2 @ 4 (100)	SOLID SOLID	YELLOW YELLOW	5/2 (140) C-C FROM SKIP-DASH CENTERLINE 11 (280) C-C OMIT SKIP-DASH CENTERLINE BETWEEN
LANE LINES	4 (100) 5 (125) ON FREEWAYS	SKIP-DASH SKIP-DASH	WHITE WHITE	10' (3 m) LINE WITH 30' (9 m) SPACE
DOTTED LINES (EXTENSIONS OF CENTER, LANE OR TURN LANE MARKINGS)	SAME AS LINE BEING EXTENDED	SKIP-DASH	SAME AS LINE BEING EXTENDED	2' (600) LINE WITH 6' (1.8 m) SPACE
EDGE LINES	4 (100)	SOLID	YELLOW-LEFT WHITE-RIGHT	OUTLINE MOUNTABLE MEDIANS IN YELLOW; EDGE LINES ARE NOT USED NEXT TO BARRIER CURB
TURN LANE MARKINGS	6 (150) LINE; FULL SIZE LETTERS & SYMBOLS (8' (2.4m))	SOLID	WHITE	SEE TYPICAL TURN LANE MARKING DETAIL
TWO WAY LEFT TURN MARKING	2 @ 4 (100) EACH DIRECTION 8' (2.4m) LEFT ARROW	SKIP-DASH AND SOLID IN PAIRS	YELLOW WHITE	10' (3 m) LINE WITH 30' (9 m) SPACE FOR SKIP-DASH; 5/2 (140) C-C BETWEEN SOLID LINE AND SKIP-DASH LINE SEE TYPICAL TWO-WAY LEFT TURN MARKING DETAIL
CROSSWALK LINES (PEDESTRIAN) A. DIAGONALS (BIKE & EQUESTRIAN) B. LONGITUDINAL BARS (SCHOOL)	2 @ 6 (150) 12 (300) @ 45° 12 (300) @ 90°	SOLID SOLID SOLID	WHITE WHITE WHITE	NOT LESS THAN 6' (1.8 m) APART 2' (600) APART 2' (600) APART SEE TYPICAL CROSSWALK MARKING DETAILS.
STOP LINES	24 (600)	SOLID	WHITE	PLACE 4' (1.2 m) IN ADVANCE OF AND PARALLEL TO CROSSWALK, IF PRESENT. OTHERWISE PLACE AT DESIRED STOPPING POINT, PARALLEL TO CROSSROAD CENTERLINE, WHERE POSSIBLE
PAINTED MEDIANS	2 @ 4 (100) WITH 12 (300) DIAGONALS @ 45° NO DIAGONALS USED FOR 4' (1.2 m) WIDE MEDIANS	SOLID	YELLOW; TWO WAY TRAFFIC WHITE; ONE WAY TRAFFIC	11 (280) C-C FOR THE DOUBLE LINE SEE TYPICAL PAINTED MEDIAN MARKING.
GORE MARKING AND CHANNELIZING LINES	8 (200) WITH 12 (300) DIAGONALS @ 45°	SOLID	WHITE	DIAGONALS: 15' (4.5 m) C-C (LESS THAN 30MPH (50 km/h)) 20' (6 m) C-C 30MPH (50 km/h) TO 45MPH (70 km/h) 30' (9 m) C-C (OVER 45MPH (70 km/h))
RAILROAD CROSSING	24 (600) TRANSVERSE LINES; "RR" IS 6' (1.8 m) LETTERS; 16 (400) LINE FOR "X"	SOLID	WHITE	SEE STATE STANDARD 78001 AREA OF: "R"=3.6 SQ. FT. (0.33 m ²) EACH "X"=54.0 SQ. FT. (5.0 m ²)
SHOULDER DIAGONALS	12 (300) @ 45°	SOLID	WHITE - RIGHT YELLOW - LEFT	50' (15 m) C-C (LESS THAN 30MPH (50 km/h)) 75' (25 m) C-C (30 MPH (50 km/h) TO 45MPH (70 km/h)) 150' (45 m) C-C (OVER 45MPH (70 km/h))

FOR FURTHER DETAILS ON PAVEMENT MARKING REFER TO STANDARD SPECIFICATIONS FOR ROAD AND BRIDGE CONSTRUCTION AND STATE STANDARD 78001.

All dimensions are in inches (millimeters) unless otherwise shown.

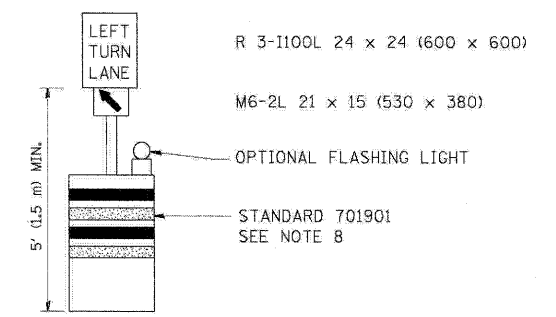
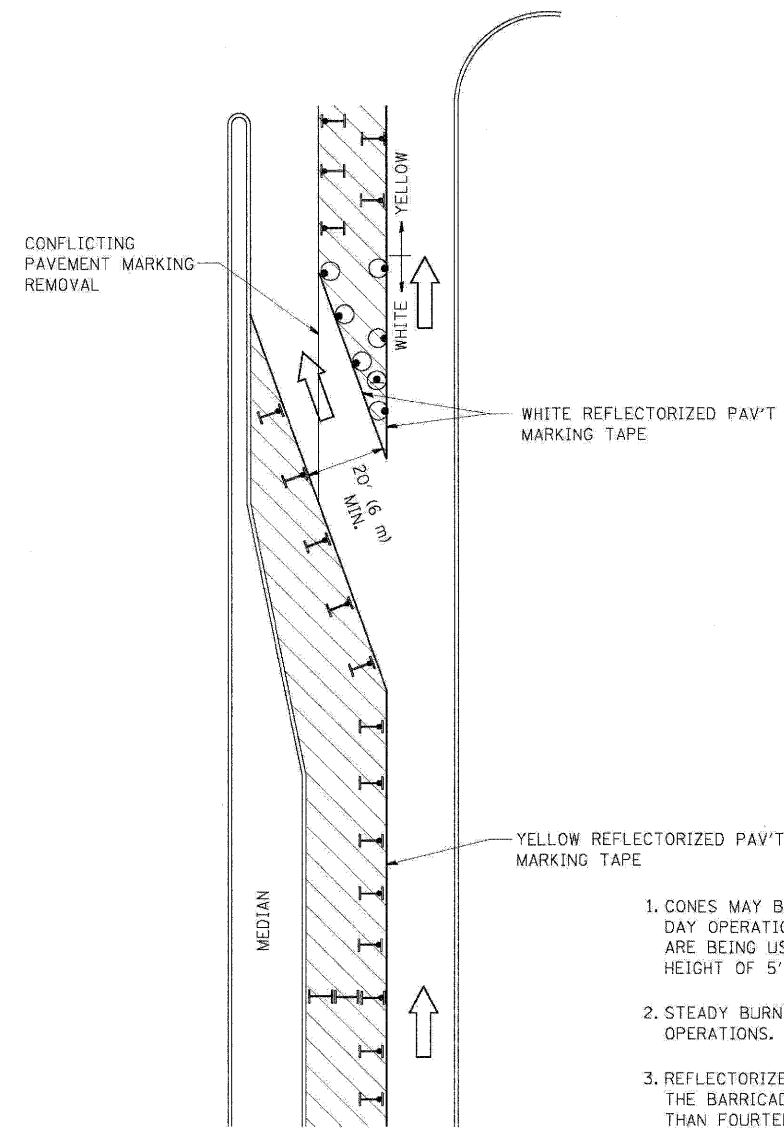





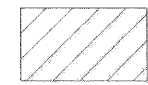

GENERAL NOTES

1. CONES MAY BE SUBSTITUTED FOR BARRICADES OR DRUMS AT HALF THE SPACING DURING DAY OPERATIONS. CONES SHALL BE A MINIMUM OF 28 (710) IN HEIGHT. WHEN CONES ARE BEING USED, THE "LEFT TURN LANE" SIGN MAY BE SKID MOUNTED AT A MINIMUM HEIGHT OF 5' (1.5 m).
2. STEADY BURNING LIGHTS WILL NOT BE REQUIRED ON BARRICADES OR DRUMS FOR DAY OPERATIONS. ALL LIGHTS SHALL BE MONODIRECTIONAL.
3. REFLECTORIZED TEMPORARY PAVEMENT MARKING TAPE SHALL BE PLACED THROUGHOUT THE BARRICADED AREA OF EACH TURN BAY WHERE THE CLOSURE TIME IS GREATER THAN FOURTEEN DAYS.
4. THIS APPLICATION ALSO APPLIES WHEN WORK IS BEING PERFORMED IN THE RIGHT LANE(S) AND THE RIGHT TURN BAY IS TO REMAIN OPEN. UNDER THIS CONDITION, "RIGHT TURN LANE" R3-100 24 x 24 (600 x 600) AND M6-2R 21 x 15 (530 x 380) SHALL BE USED.
5. THESE CONTROLS SHALL SUPPLEMENT MAINLINE TRAFFIC CONTROL FOR LANE CLOSURES.
6. LONGITUDINAL DIMENSIONS MAY BE ADJUSTED TO FIT FIELD CONDITIONS.
7. FORM OPER 725 IS REQUIRED.
8. IF A DRUM OR TYPE II BARRICADE WITH AN ATTACHED SIGN PANEL WHICH MEETS NCHRP 350 REQUIREMENTS IS NOT AVAILABLE, THE SIGNS SHALL BE MOUNTED, ABOVE THE BARRICADES, ON SEPARATE SIGNS SUPPORTS THAT MEET NCHR 350 PREQUIREMENTS.
9. TRAFFIC CONTROL AND PROTECTION AT TURN BAYS (TO REMAIN OPEN TO TRAFFIC) SHALL BE INCLUDED IN THE COST SPECIFIED TRAFFIC CONTROL STANDARDS OR ITEMS.

All dimensions are in inches (millimeters) unless otherwise shown.

LEGEND

-  WORK AREA
-  LANE OPEN TO TRAFFIC
-  TYPE I OR II BARRICADE WITH STEADY BURN LIGHT
-  DRUM WITH STEADY BURN LIGHT
-  DRUM WITH SIGN (WITH OPTIONAL FLASHING LIGHT) SEE DETAIL
-  TYPE I OR II CHECK BARRICADE WITH FLASHING LIGHT

FILE NAME =	USER NAME = chrsvakosgn	REVISED - T. RAMMACHER 09-08-94	REVISED - R. BORO 09-14-09
er:\pwwork\pww\DOT\DRIVAK\USGN\0108318\14.dgn		REVISED - A. HOUSEH 11-07-95	REVISED -
PLOT SCALE = 49.9999 1/1 IN.		REVISED - A. HOUSEH 10-12-96	REVISED -
PLOT DATE = 9/14/2009		REVISED - T. RAMMACHER 01-06-00	REVISED -

**STATE OF ILLINOIS
DEPARTMENT OF TRANSPORTATION**

**TRAFFIC CONTROL AND PROTECTION AT TURN BAYS
(TO REMAIN OPEN TO TRAFFIC)**

SCALE: NONE SHEET NO. 1 OF 1 SHEETS STA. TO STA.

F.A. RTE.	SECTION	COUNTY	TOTAL SHEETS	SHEET NO.
	04-00092-00-BR	KANE	440	435
TC-14		CONTRACT NO. 63650		
FED. ROAD DIST. NO. 1 ILLINOIS FED. AID PROJECT				

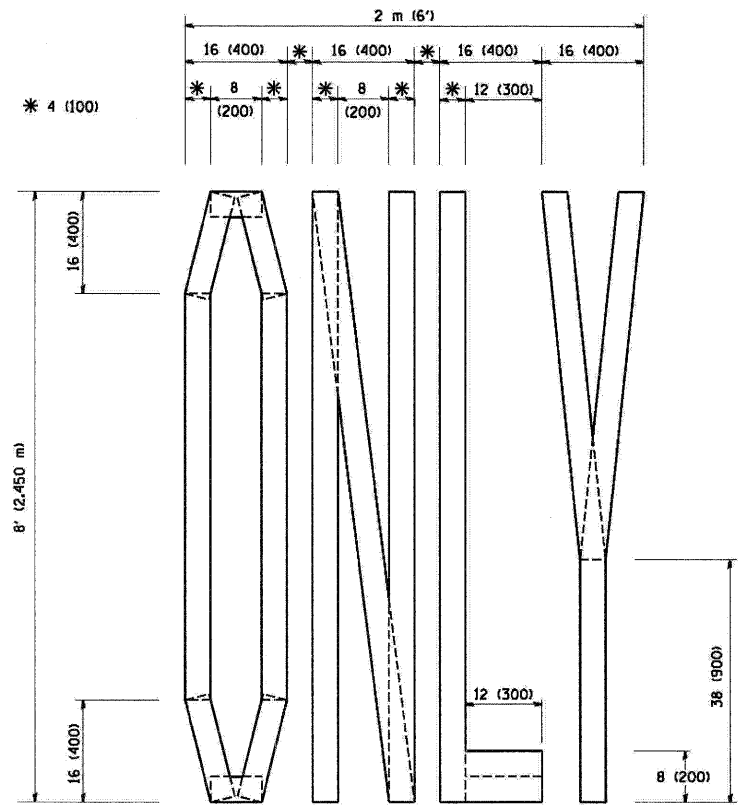

QUANTITY
 4 (100) LINE = 64.1 ft. (19.7 m)
 21.1 sq. ft. (1.97 sq. m)

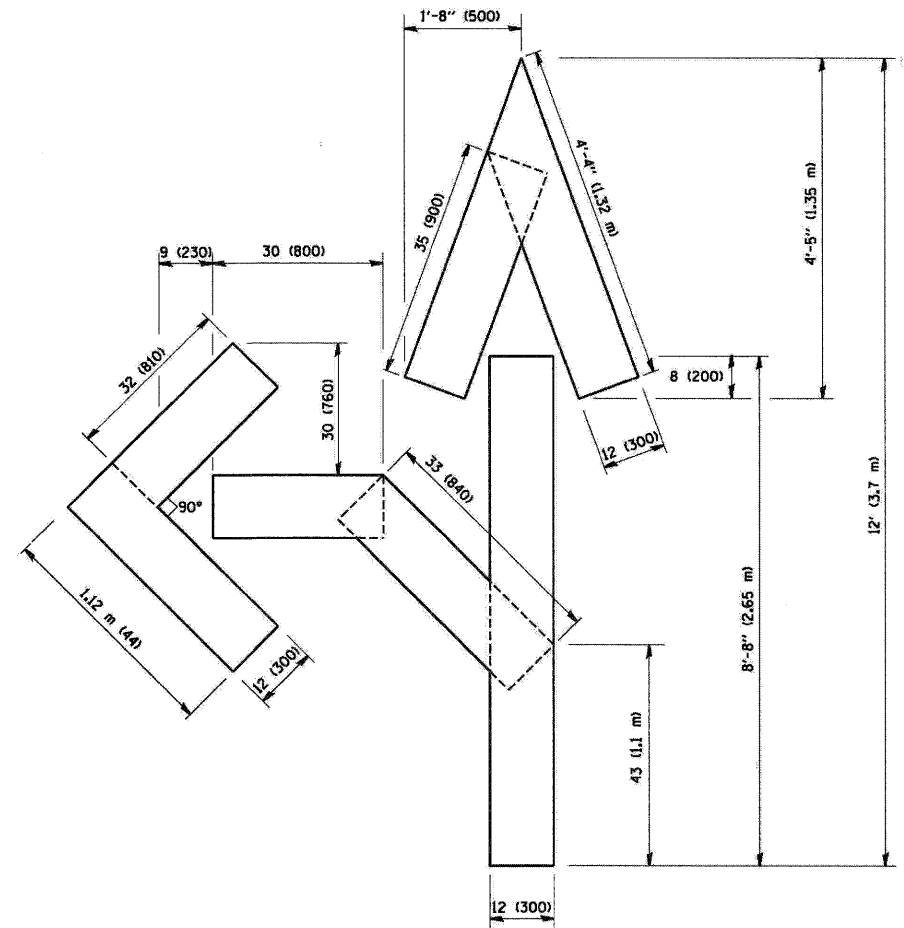

QUANTITY
 4 (100) LINE = 82.5 ft. (25.3 m)
 27.5 sq. ft. (2.53 sq. m)

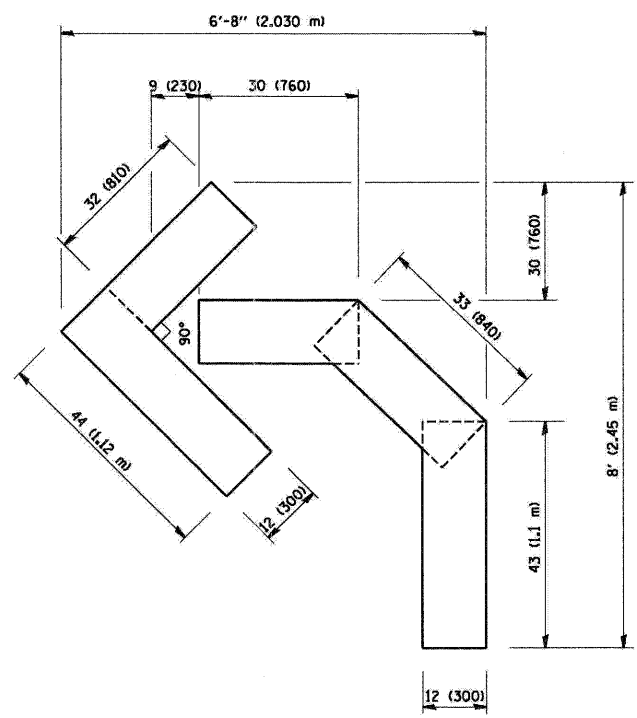

QUANTITY
 4 (100) LINE = 45.5 ft. (13.9 m)
 15.2 sq. ft. (1.39 sq. m)

All dimensions are in inches (millimeters) unless otherwise shown.

FILE NAME = W:\dstatd\22x34\tcl5.dgn	USER NAME = gaglianobt	DESIGNED -	REVISED - T. RAMMACHER 06-05-96	STATE OF ILLINOIS DEPARTMENT OF TRANSPORTATION	PAVEMENT MARKING LETTERS AND SYMBOLS FOR TRAFFIC STAGING			F.A. RTE. *	SECTION	COUNTY	TOTAL SHEETS	SHEET NO.
	PLOT SCALE = 50.0000" / IN.	CHECKED -	REVISED - T. RAMMACHER 11-04-97					04-00092-00-BR	KANE	440	436	
PLOT DATE = 1/4/2008	DATE = 09-18-94	REVISED - E. GOMEZ 08-28-00	REVISED - T. RAMMACHER 03-02-98		SCALE: NONE	SHEET NO. 1 OF 1 SHEETS	STA. TO STA.	TC-16		CONTRACT NO. 63650		
								FED. ROAD DIST. NO. 1 ILLINOIS FED. AID PROJECT				

SIGNING FOR FLAGGING OPERATIONS AT WORK ZONE OPENINGS

WORK ZONE EXIT OPENING

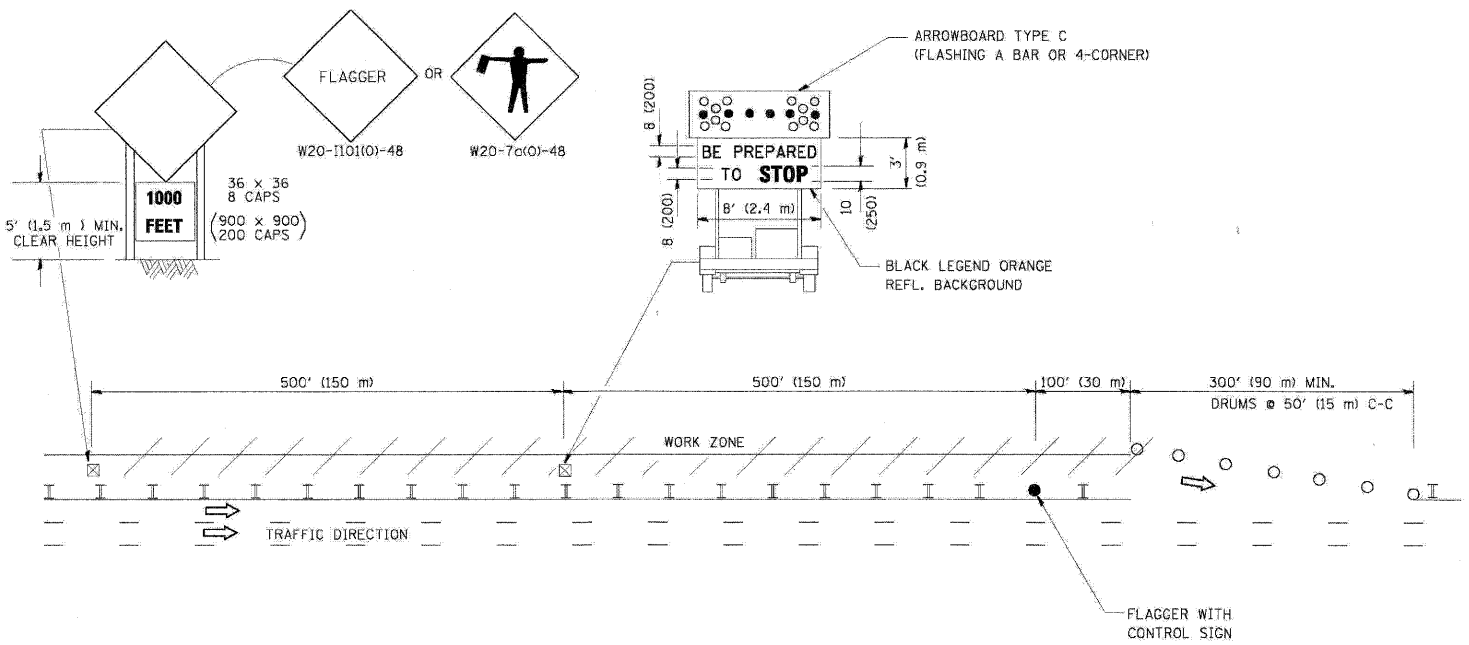

WORK ZONE ENTRY OPENING

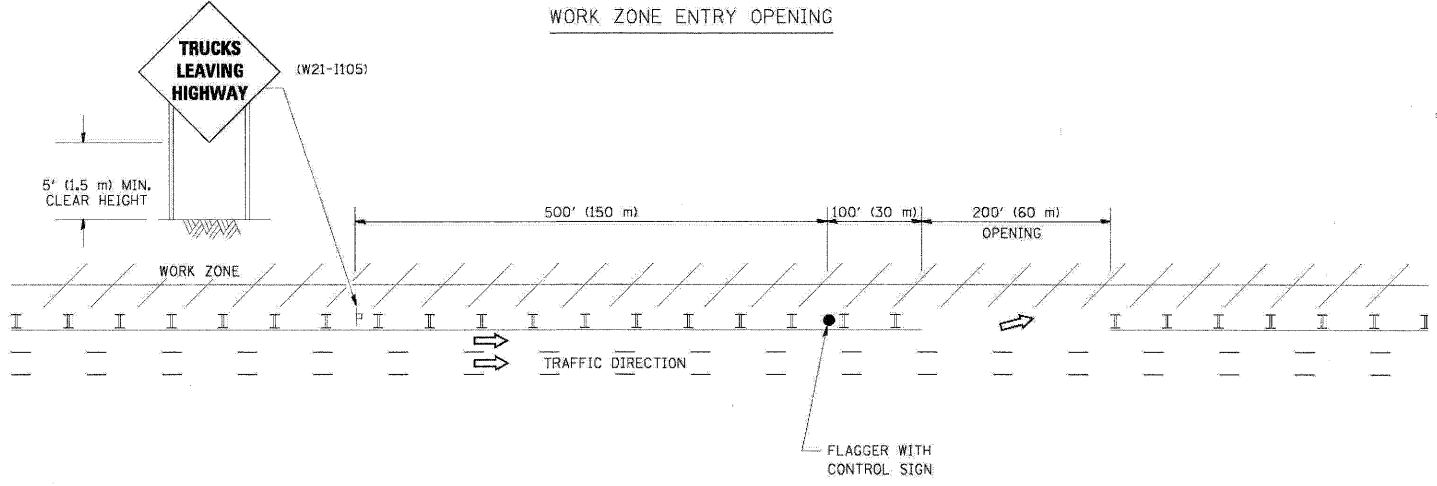

- NOTES:
1. THE ARROWBOARD, THE FLAGGER AHEAD SIGN AND THE TRUCKS LEAVING HIGHWAY SIGN SHALL BE REMOVED OR TURNED AWAY FROM TRAFFIC AND THE EXIT AND ENTRY OPENINGS SHALL BE CLOSED WHEN THE FLAGGING OPERATION CEASES. NON OPERATING EQUIPMENT SHALL COMPLY WITH ARTICLE 701.11
 2. WORK ZONE EXIT OPENINGS SHOULD BE A MINIMUM OF ONE HALF MILE APART.
 3. EXITING THE WORK ZONE AT ANY PLACE OTHER THAN AT A WORK ZONE EXIT OPENING WILL BE PROHIBITED.
 4. ALL VEHICLES SHALL ENTER THE WORK ZONE AT ENTRY OPENINGS, USING THEIR TURN SIGNALS TO WARN MOTORISTS

ALL DIMENSIONS ARE IN INCHES (MILLIMETERS) UNLESS OTHERWISE SHOWN

FILE NAME = W:\dsstatd\22634\1018.dgn	USER NAME = Leyan	DESIGNED * DRAWN -	REVISED - REVISED -
		CHECKED * DATE -	REVISED - REVISED -

**STATE OF ILLINOIS
DEPARTMENT OF TRANSPORTATION**

**SIGNING FOR FLAGGING OPERATIONS
AT WORK ZONE OPENINGS**

SCALE: NONE SHEET NO. 1 OF 1 SHEETS STA. TO STA.

F.A. RTE.	SECTION	COUNTY	TOTAL SHEETS	SHEET NO.
	04-00092-00-BR	KANE	440	437
TC-18		CONTRACT NO. 63650		
FED. ROAD DIST. NO. 1 ILLINOIS FED. AID PROJECT				

ROUTE MARKERS

FOR U.S. ROUTES
M1-40-2424

FOR ILLINOIS ROUTES
M1-50-2424

R.R. UNMARKED ROUTES
SPECIAL 24" x 18" VARIABLE
4" BLACK LETTERS ON WHITE
REFLECTIVE BACKGROUND

ARROWS SIGNS

M5-1L-2115

M5-1R-2115

M6-1-2115

M6-1-2115

M6-3-2115

CARDINAL DIRECTION & DETOUR SIGNS

NORTH M3-1-2412

EAST M3-2-2412

SOUTH M3-3-2412

WEST M3-4-2412

DETOUR M4-8-2412

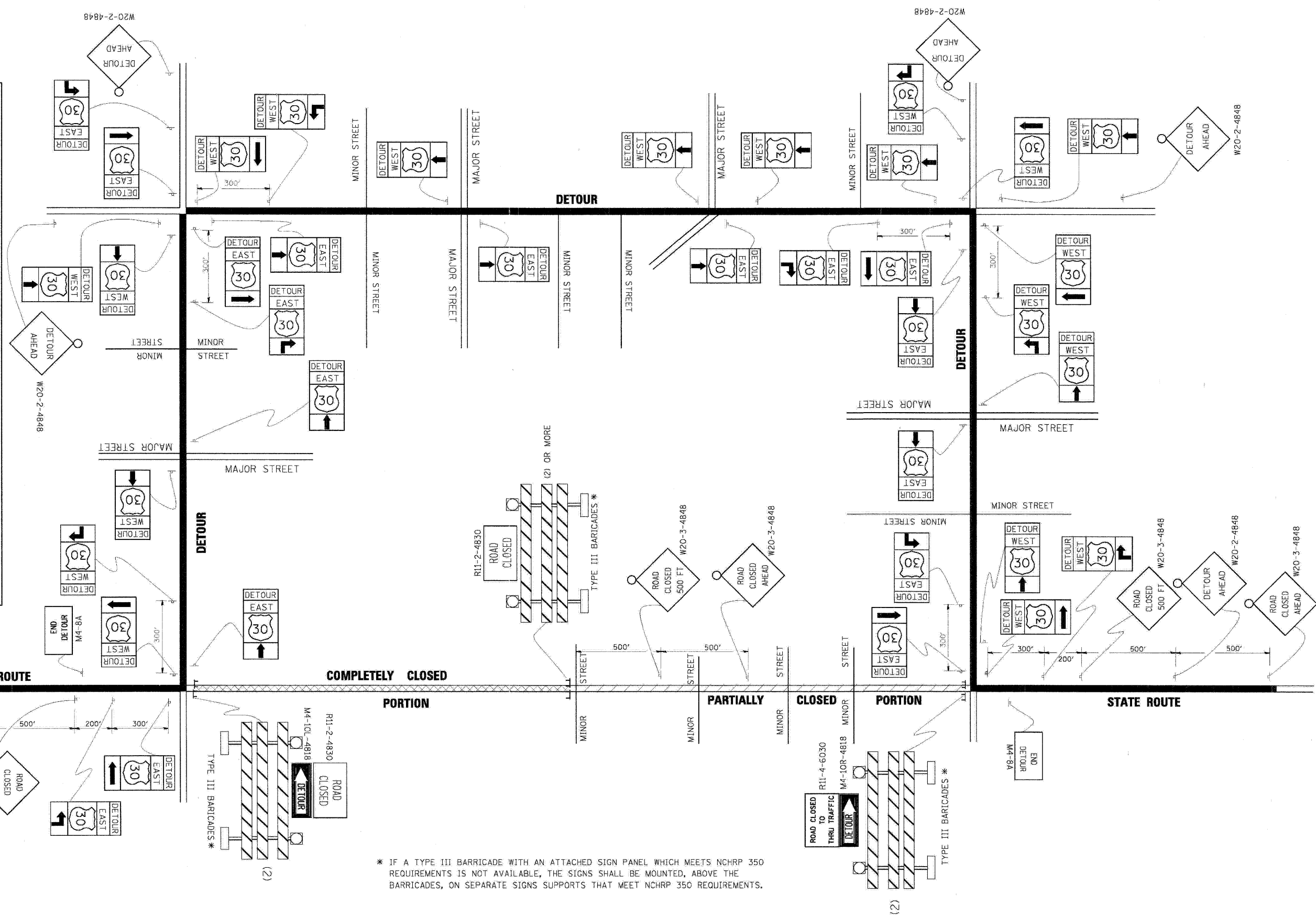

* IF A TYPE III BARRICADE WITH AN ATTACHED SIGN PANEL WHICH MEETS NCHRP 350 REQUIREMENTS IS NOT AVAILABLE, THE SIGNS SHALL BE MOUNTED, ABOVE THE BARRICADES, ON SEPARATE SIGNS SUPPORTS THAT MEET NCHRP 350 REQUIREMENTS.

FILE NAME =	USER NAME = drivakogn	DESIGNED -	REVISED - 10-18-02	STATE OF ILLINOIS DEPARTMENT OF TRANSPORTATION	DETOUR SIGNING FOR CLOSING STATE HIGHWAYS			F.A. RTE.	SECTION	COUNTY	TOTAL SHEETS	SHEET NO.
6:\pwwork\pwwork\DRIVAK\OSG\10883\5\1021.dgn		DRAWN -	REVISED - R. BORO 09-14-09		SCALE: NONE	SHEET NO. 1 OF 1 SHEETS	STA.	TO STA.	04-00092-00-BR	KANE	440	438
PLOT SCALE = 49.99999 / IN.		CHECKED -	REVISED -		TC-21			CONTRACT NO. 63650				
PLOT DATE = 9/14/2009		DATE -	REVISED -		FED. ROAD DIST. NO. 1 [ILLINOIS] FED. AID PROJECT							

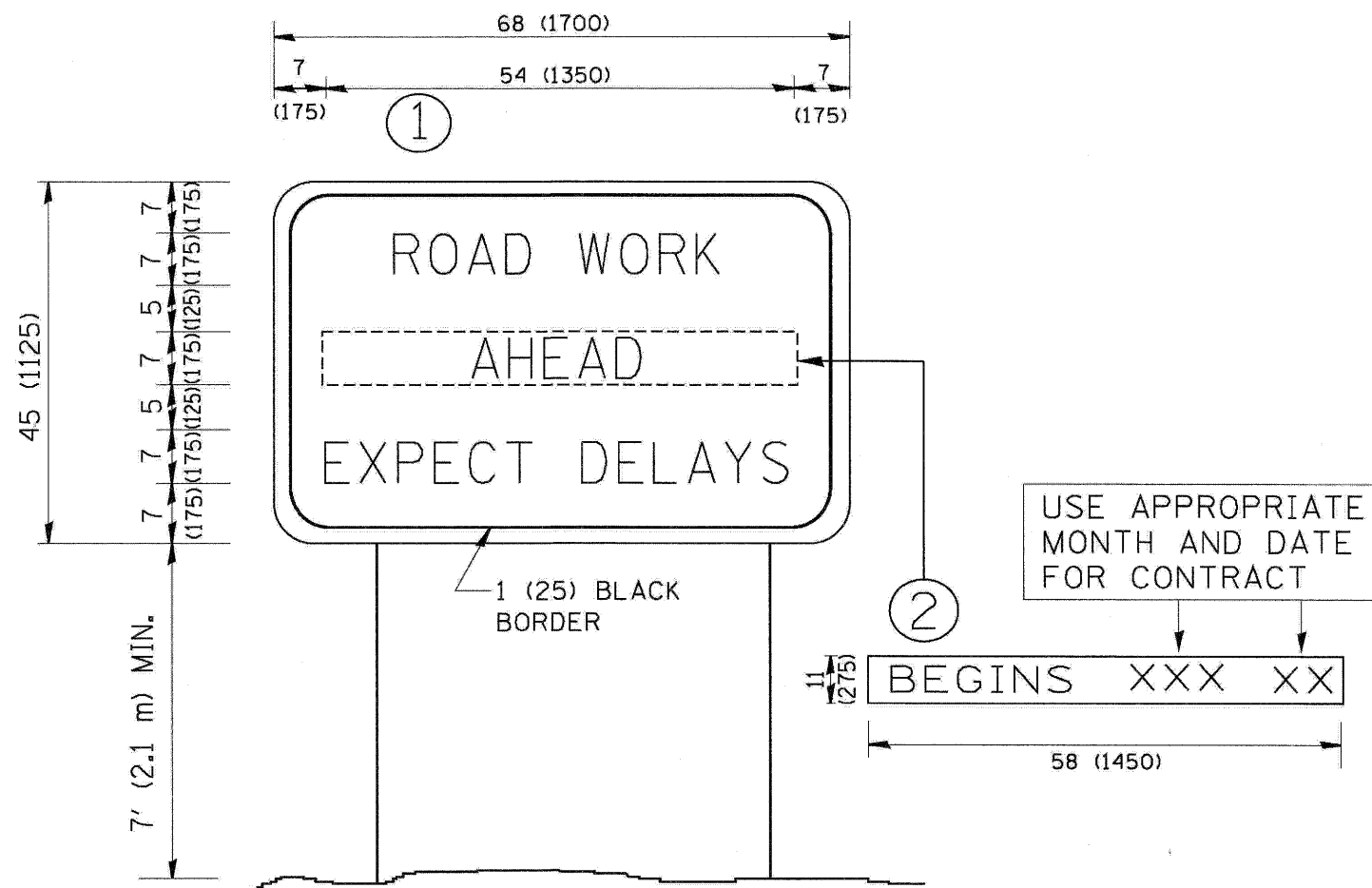

NOTES:

1. USE BLACK LETTERING ON ORANGE BACKGROUND.
2. ERECT SIGNS IN ADVANCE OF THE LOCATION FOR THE "ROAD CONSTRUCTION AHEAD" SIGN AT LOCATIONS AS DIRECTED BY THE ENGINEER.
3. ERECT SIGN ① WITH INSTALLED PANEL ② ONE WEEK PRIOR TO THE START OF CONSTRUCTION.
4. REMOVE PANEL ② SOON AFTER THE START OF CONSTRUCTION.
5. SEE SPECIAL PROVISION FOR "TEMPORARY INFORMATION SIGNING" FOR ADDITIONAL INFORMATION.
6. ONE SIGN ASSEMBLY EQUALS 25.70 SQ. FT. (2.3 SQ. M.)
7. SHALL BE PAID FOR AS TEMPORARY INFORMATION SIGNING.

ALL DIMENSIONS ARE IN INCHES (MILLIMETERS) UNLESS OTHERWISE SHOWN.

FILE NAME = W:\distatd\22x34\to22.dgn	USER NAME = geglianobt	DESIGNED -	REVISED - R. MIRS 09-15-97	STATE OF ILLINOIS DEPARTMENT OF TRANSPORTATION	ARTERIAL ROAD INFORMATION SIGN			F.A. RTE.	SECTION	COUNTY	TOTAL SHEETS	SHEET NO.	
	PLOT SCALE = 50,000 ' / IN.	DRAWN -	REVISED - R. MIRS 12-11-97		SCALE: NONE	SHEET NO. 1 OF 1 SHEETS	STA.	TO STA.	04-00092-00-BR	KANE	440	439	
	PLOT DATE = 1/4/2008	CHECKED -	REVISED - T. RAMMACHER 02-02-99						TC-22				
		DATE -	REVISED - C. JUCIUS 01-31-07						FED. ROAD DIST. NO. 1	ILLINOIS	FED. AID PROJECT		CONTRACT NO. 63650

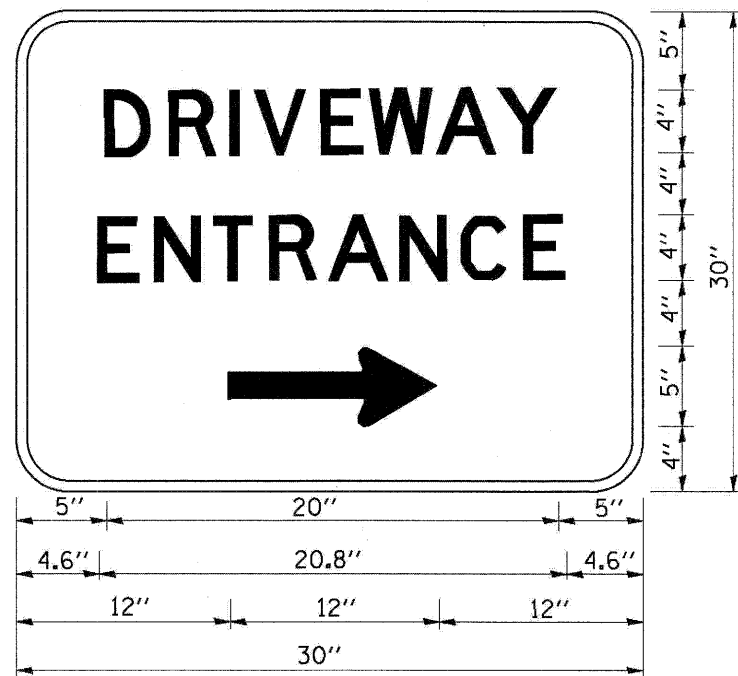

3.0" RADIUS, 0.5" BORDER, WHITE ON GREEN; REFLECTORIZED
 "DRIVEWAY" D; "ENTRANCE" D; STANDARD ARROW CUSTOM 12.0" x 5.0"

NOTES:

1. HALF OF THE SIGNS WILL REQUIRE A LEFT HAND FACING ARROW.
2. TWO SIGNS SHALL BE USED AT EACH COMMERCIAL ENTRANCE PLACED BACK-TO-BACK: ONE WITH A RIGHT HAND ARROW (SHOWN) SHALL BE PLACED ON THE NEAR RIGHT SIDE THE DRIVEWAY AND ONE WITH A LEFT HAND ARROW SHALL BE PLACED ON THE FAR LEFT SIDE OF THE DRIVEWAY.
3. SIGNS TO BE PAID FOR AS ITEM "TEMPORARY INFORMATION SIGNING".

FILE NAME = W:\distatd\22x34\to26.dgn	USER NAME = geglienobt	DESIGNED -	REVISED - C. JUCIUS 02-15-07	STATE OF ILLINOIS DEPARTMENT OF TRANSPORTATION	DRIVEWAY ENTRANCE SIGNING			F.A. RTE.	SECTION	COUNTY	TOTAL SHEETS	SHEET NO.
	PLOT SCALE = 60,000' / IN.	DRAWN -	REVISED -					04-00092-00-BR	KANE	440	440	
	PLOT DATE = 1/4/2008	CHECKED -	REVISED -					TC-26		CONTRACT NO. 63650		
				SCALE: NONE	SHEET NO. 1 OF 1 SHEETS	STA.	TO STA.	FED. ROAD DIST. NO. 1 ILLINOIS FED. AID PROJECT				