

USER NAME = .USERNAME.
 DESIGNED - CGC
 DRAWN - CGC
 CHECKED - AM
 DATE - 10/14/2011
 PLOT SCALE = 50.0000 / IN.
 PLOT DATE = 10/19/2011

REVISED -
 REVISED -
 REVISED -
 REVISED -







STATE OF ILLINOIS
DEPARTMENT OF TRANSPORTATION

MOT I-90 STAGE 3
 SCALE: 1"=50' SHEET NO. OF SHEETS STA. 995+00 TO STA. 9+00

F.A.I. RTE.	SECTION	COUNTY	TOTAL SHEETS	SHEET NO.
90	(X2-1)R	WINNEBAGO	510	201
CONTRACT NO. 64C29			ILLINOIS FED. AID PROJECT	



LEGEND

-  WORK ZONE
-  TEMPORARY PAVEMENT
-  TEMPORARY CONCRETE BARRIER
-  DIRECTION OF TRAFFIC
-  DRUMS WITH BI-DIRECTIONAL STEADY BURN LIGHTS @ 50' CENTERS, 25' CENTERS ALONG TAPERS
-  IMPACT ATTENUATOR, TEMPORARY (NON-REDIRECTIVE)
-  VERTICAL PANEL

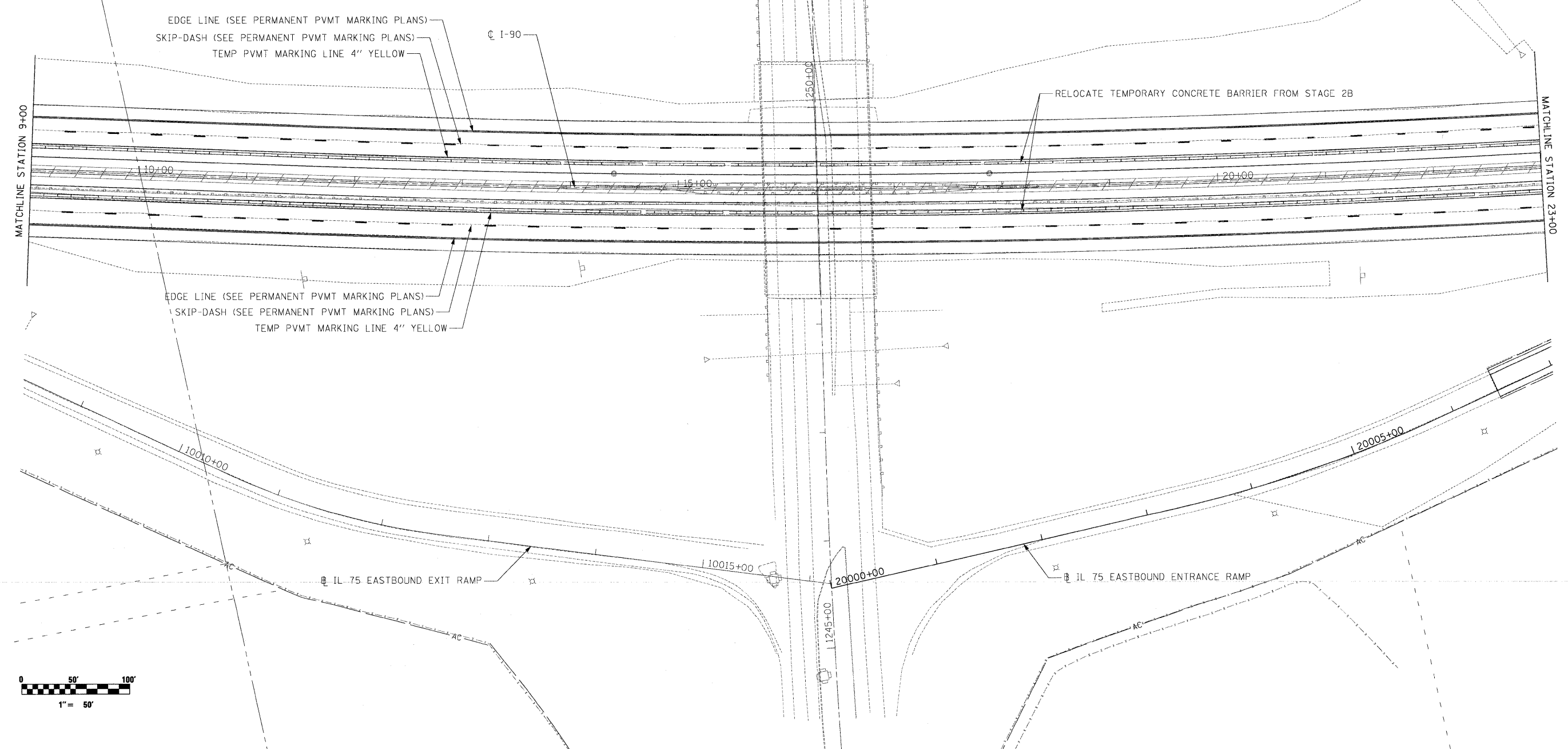

McClure LOCHNER
Engineering Associates, Inc.
RWA
Engineering Inc.

USER NAME = .USERNAME.
PLOT SCALE = 50,0000 ' / IN.
PLOT DATE = 10/19/2011

DESIGNED - CGC
DRAWN - CGC
CHECKED - AM
DATE - 10/14/2011

REVISED -
REVISED -
REVISED -
REVISED -

**STATE OF ILLINOIS
DEPARTMENT OF TRANSPORTATION**

MOT I-90 STAGE 3

SCALE: 1"=50' SHEET NO. OF SHEETS STA. 9+00 TO STA. 23+00

F.A.I. RTE. 90	SECTION (X2-1)R	COUNTY WINNEBAGO	TOTAL SHEETS 510	SHEET NO. 202
CONTRACT NO. 64C29				
ILLINOIS FED. AID PROJECT				

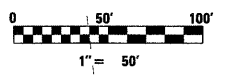
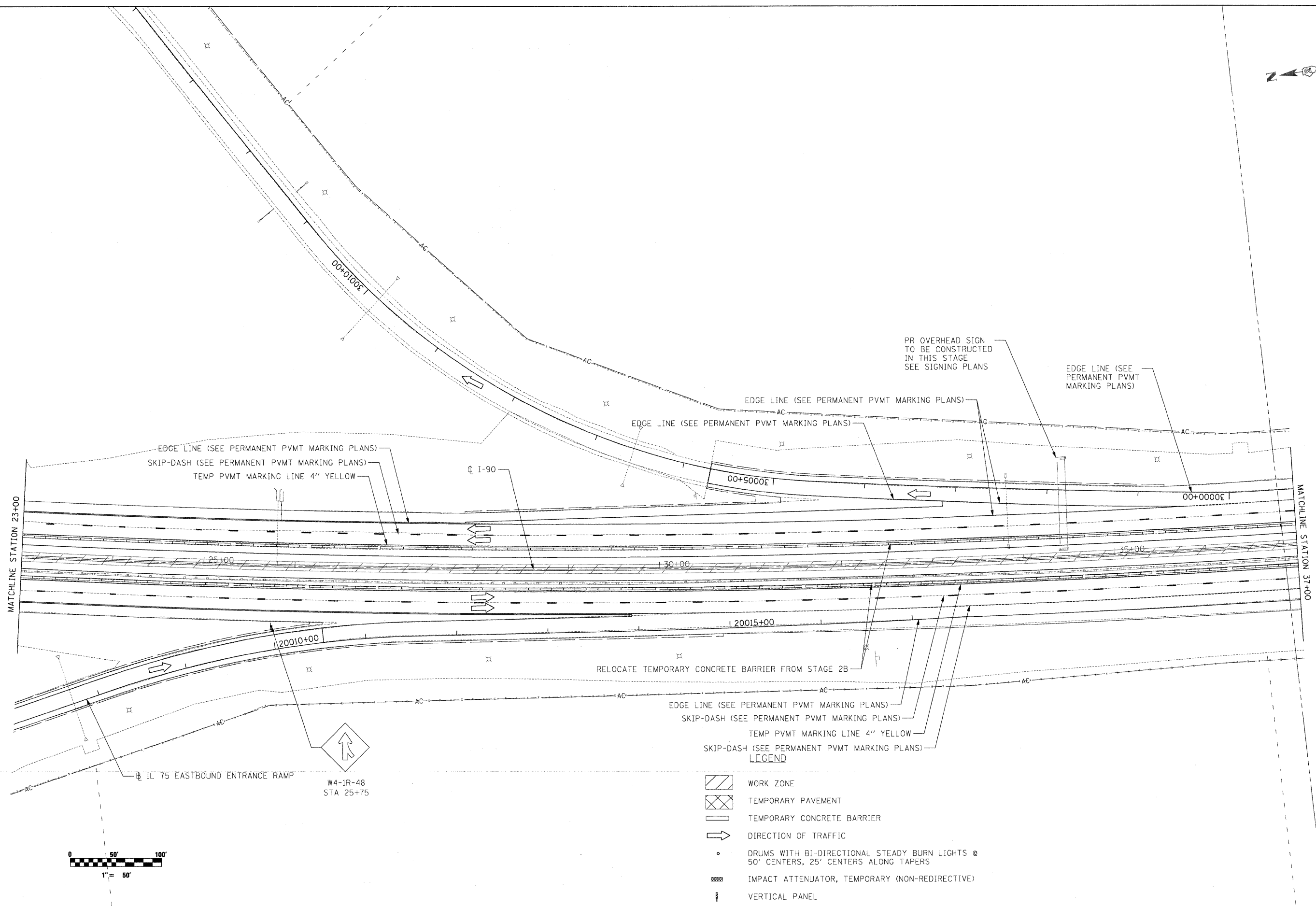

- LEGEND
- WORK ZONE
 - TEMPORARY PAVEMENT
 - TEMPORARY CONCRETE BARRIER
 - DIRECTION OF TRAFFIC
 - DRUMS WITH BI-DIRECTIONAL STEADY BURN LIGHTS @ 50' CENTERS, 25' CENTERS ALONG TAPERS
 - IMPACT ATTENUATOR, TEMPORARY (NON-REDIRECTIVE)
 - VERTICAL PANEL

McClure LOCHNER
Engineering Architects, Inc.
RWA
Engineering Architects, Inc.

USER NAME = .USERNAME	DESIGNED - CGC	REVISED -
PLLOT SCALE = 50.0000' / IN.	DRAWN - CGC	REVISED -
PILOT DATE = 10/19/2011	CHECKED - AM	REVISED -
	DATE - 10/14/2011	REVISED -

**STATE OF ILLINOIS
DEPARTMENT OF TRANSPORTATION**

MOT I-90 STAGE 3

SCALE: 1"=50' SHEET NO. OF SHEETS STA. 23+00 TO STA. 37+00

F.A.I. RTE. 90	SECTION (X2-1)R	COUNTY WINNEBAGO	TOTAL SHEETS 510	SHEET NO. 203
CONTRACT NO. 64C29			ILLINOIS FED. AID PROJECT	

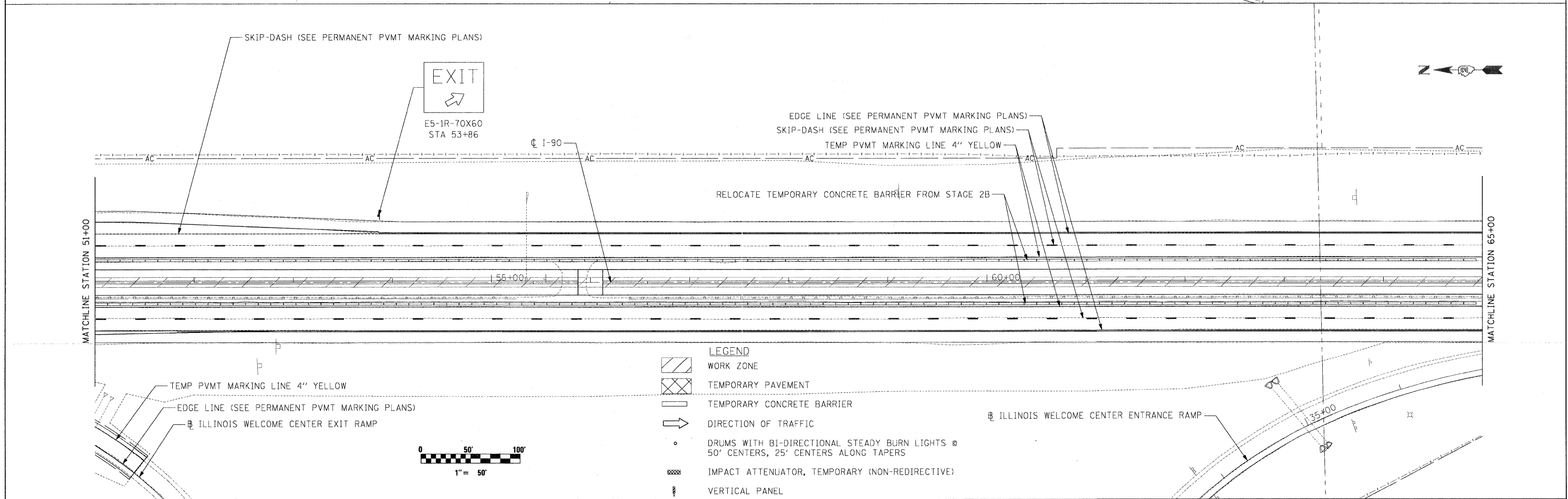
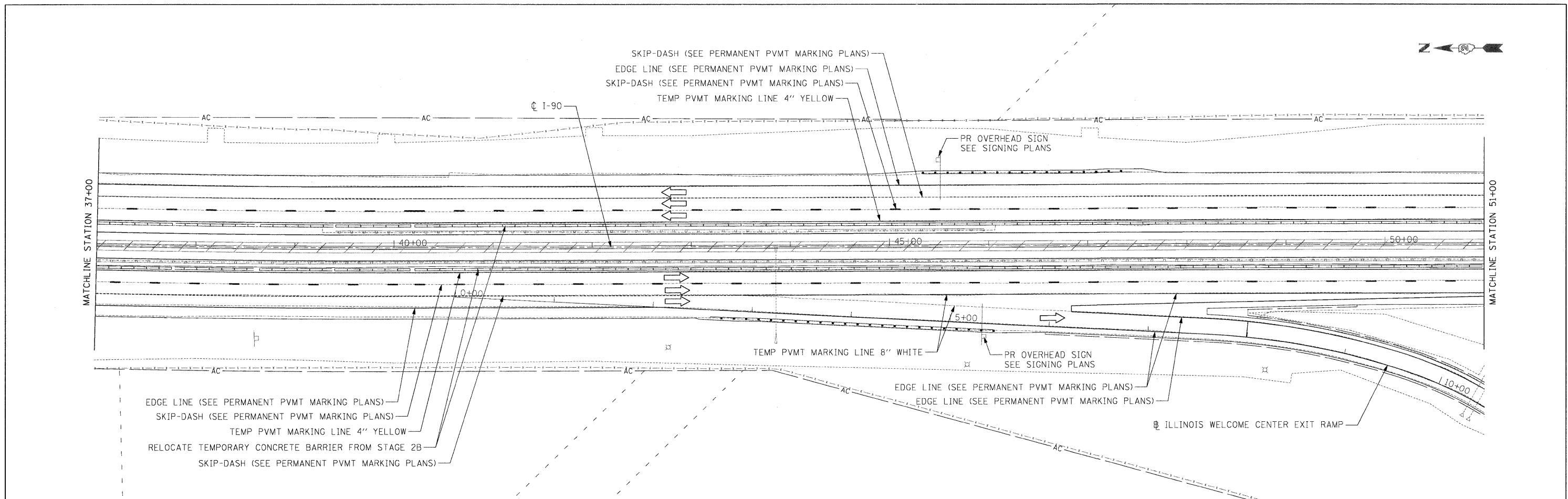

- LEGEND**
- WORK ZONE
 - TEMPORARY PAVEMENT
 - TEMPORARY CONCRETE BARRIER
 - DIRECTION OF TRAFFIC
 - DRUMS WITH BI-DIRECTIONAL STEADY BURN LIGHTS @ 50' CENTERS, 25' CENTERS ALONG TAPERS
 - IMPACT ATTENUATOR, TEMPORARY (NON-REDIRECTIVE)
 - VERTICAL PANEL

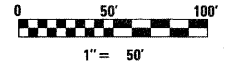

McClure LOCHNER
Engineering Associates, Inc.
RVA
Regional Water & Sewer, Inc.
O&E
Omnis Engineering, Inc.

USER NAME = .\USERNAME.	DESIGNED - CGC	REVISED -
PLOT SCALE = 50.0000' / IN.	DRAWN - CGC	REVISED -
PLOT DATE = 10/19/2011	CHECKED - AM	REVISED -
	DATE - 10/14/2011	REVISED -

**STATE OF ILLINOIS
DEPARTMENT OF TRANSPORTATION**

MOT I-90 STAGE 3

SCALE: 1"=50' SHEET NO. OF SHEETS STA. 37+00 TO STA. 65+00

F.A.I. RTE.	SECTION	COUNTY	TOTAL SHEETS	SHEET NO.
90	(X2-1R)	WINNEBAGO	510	204
CONTRACT NO. 64C29			ILLINOIS FED. AID PROJECT	

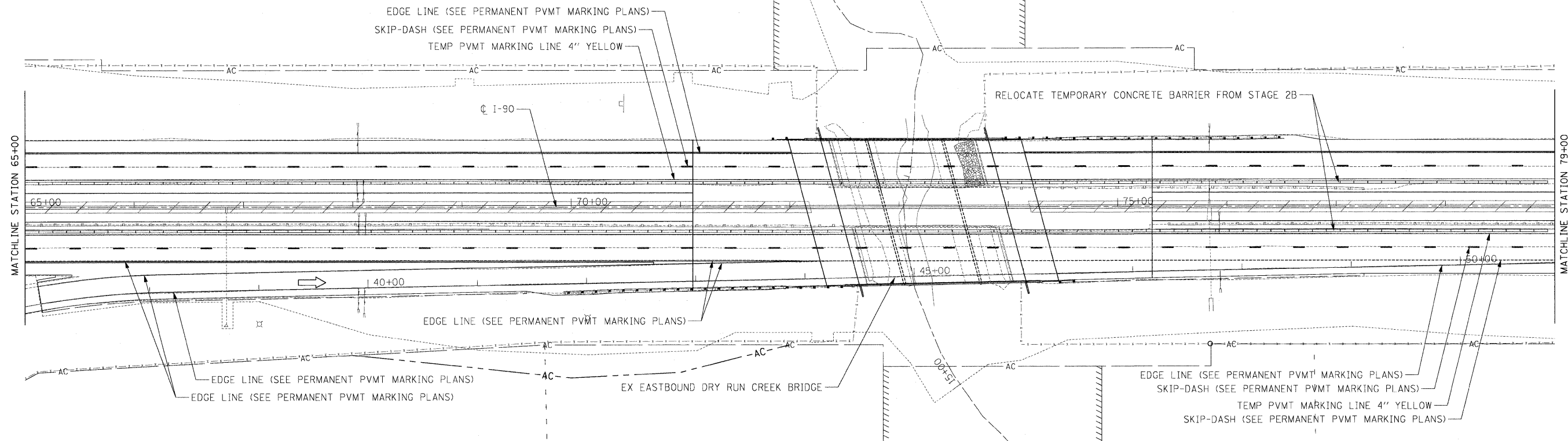

- LEGEND**
- WORK ZONE
 - TEMPORARY PAVEMENT
 - TEMPORARY CONCRETE BARRIER
 - DIRECTION OF TRAFFIC
 - DRUMS WITH BI-DIRECTIONAL STEADY BURN LIGHTS @ 50' CENTERS, 25' CENTERS ALONG TAPERS
 - IMPACT ATTENUATOR, TEMPORARY (NON-REDIRECTIVE)
 - VERTICAL PANEL

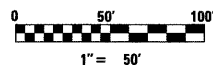
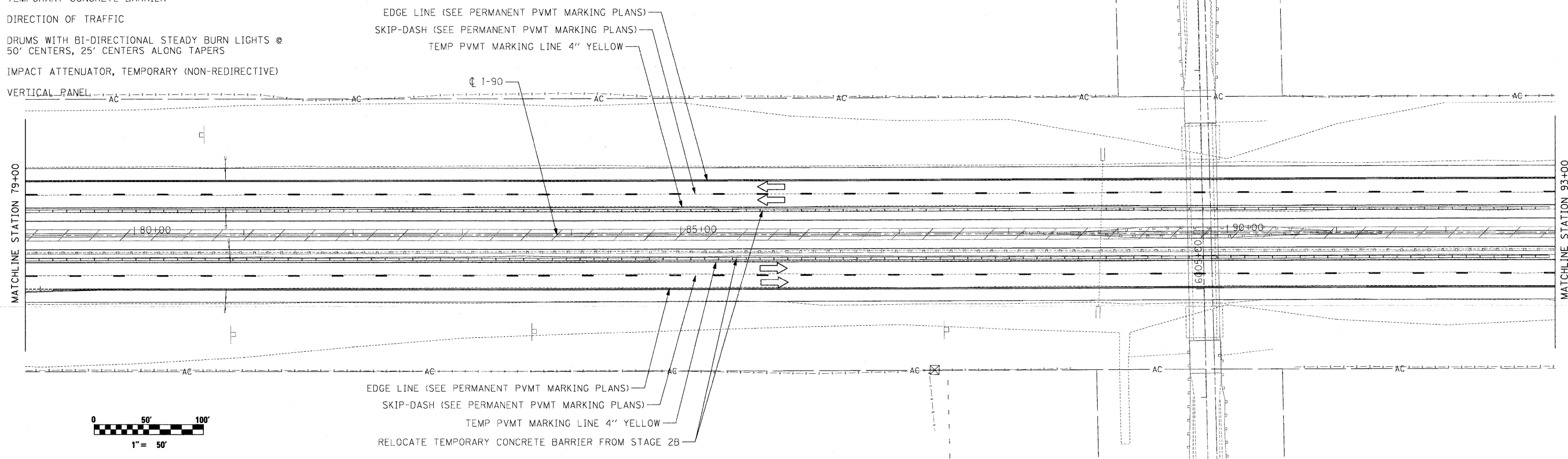

McClure LOCHNER
Engineering Associates, Inc.
RVA
QUIGO ENGINEERING ETC.







USER NAME = .USERNAME_	DESIGNED - CGC	REVISED -
PLLOT SCALE = 50.0000' / IN.	DRAWN - CGC	REVISED -
PLLOT DATE = 10/19/2011	CHECKED - AM	REVISED -
	DATE - 10/14/2011	REVISED -

**STATE OF ILLINOIS
DEPARTMENT OF TRANSPORTATION**



MOT I-90 STAGE 3

SCALE: 1"=50' SHEET NO. OF SHEETS STA. 65+00 TO STA. 93+00

F.A.I. RTE. 90	SECTION (X2-1)R	COUNTY WINNEBAGO	TOTAL SHEETS 510	SHEET NO. 205
CONTRACT NO. 64C29			ILLINOIS FED. AID PROJECT	

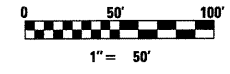
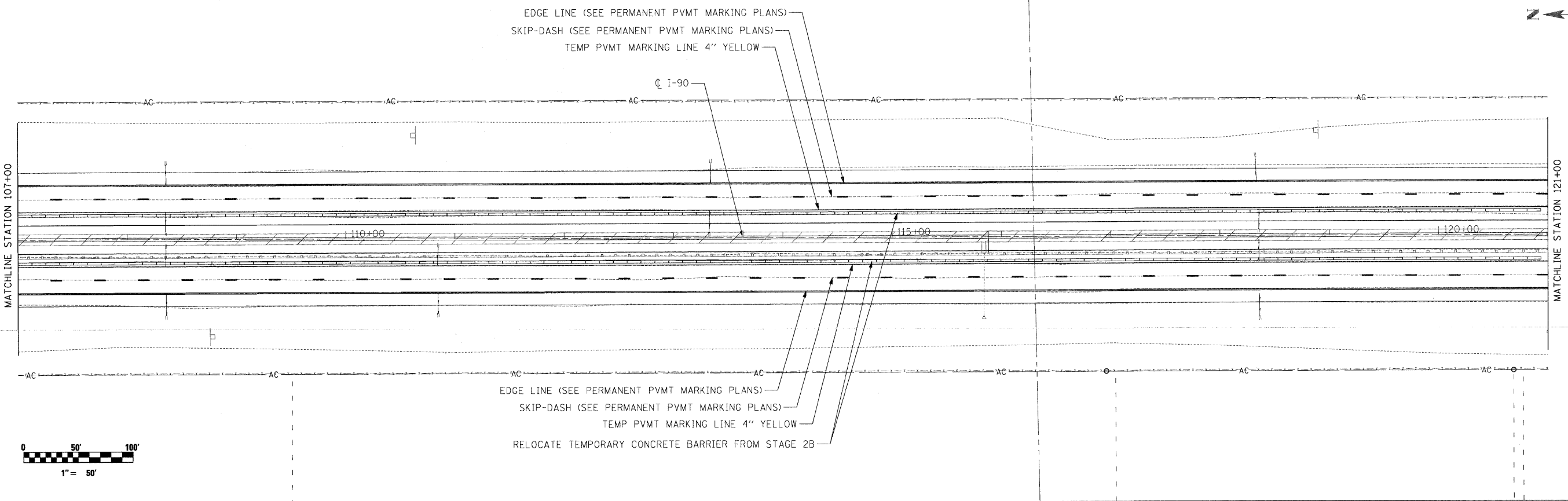
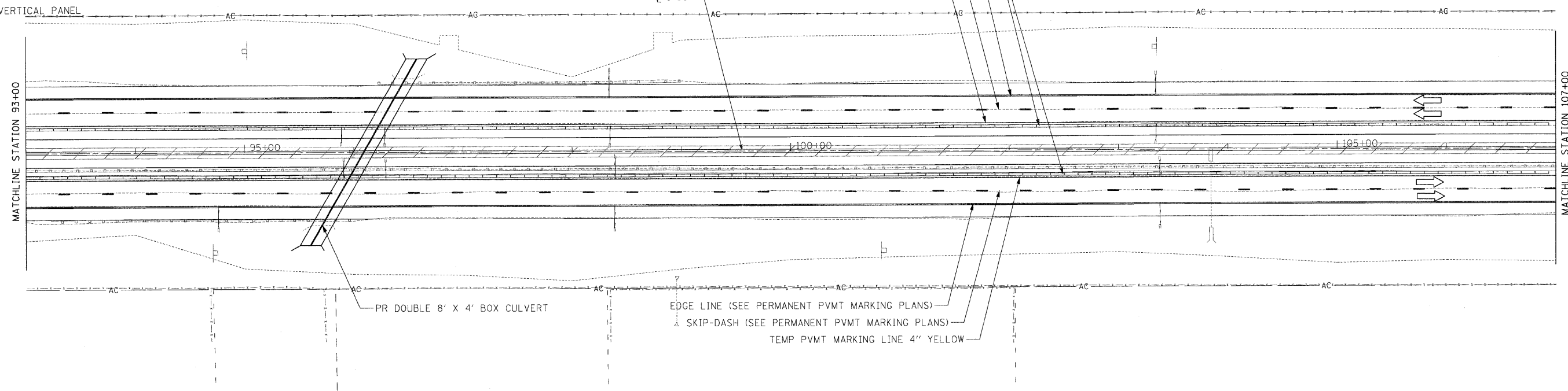
- LEGEND**
-  WORK ZONE
 -  TEMPORARY PAVEMENT
 -  TEMPORARY CONCRETE BARRIER
 -  DIRECTION OF TRAFFIC
 -  DRUMS WITH BI-DIRECTIONAL STEADY BURN LIGHTS @ 50' CENTERS, 25' CENTERS ALONG TAPERS
 -  IMPACT ATTENUATOR, TEMPORARY (NON-REDIRECTIVE)
 -  VERTICAL PANEL



  	USER NAME = .USERNAME.	DESIGNED - CGC	REVISED -	STATE OF ILLINOIS DEPARTMENT OF TRANSPORTATION	MOT I-90 STAGE 3	F.A.I. RTE. 90	SECTION (X2-1R)	COUNTY WINNEBAGO	TOTAL SHEETS 510	SHEET NO. 206
	PLOT SCALE = 50.0000' / IN. PLOT DATE = 10/19/2011	CHECKED - AM DATE - 10/14/2011	REVISED - REVISED - REVISED - REVISED -			SCALE: 1"=50' SHEET NO. OF SHEETS STA. 93+00 TO STA. 121+00	CONTRACT NO. 64C29 ILLINOIS FED. AID PROJECT			

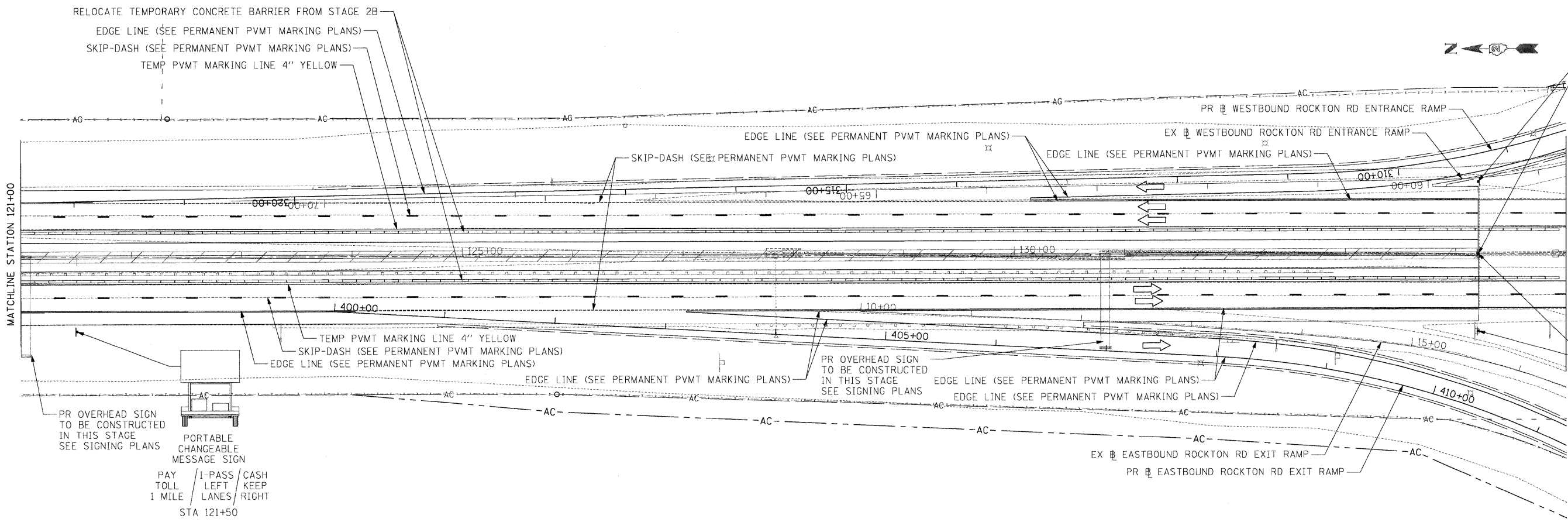

WORK ZONE
SPEED LIMIT
55
BEGINS

\$375 FINE
MINIMUM

W2-1115(0)-3618
R2-1-3648
W2-1113(0)-3612
R2-1106-3618
STA 134+20

WORK ZONE
SPEED LIMIT
45
BEGINS

\$375 FINE
MINIMUM

W2-1115(0)-3618
R2-1-3648
W2-1113(0)-3612
R2-1106-3618
STA 134+20

LEGEND

- WORK ZONE
- TEMPORARY PAVEMENT
- TEMPORARY CONCRETE BARRIER
- DIRECTION OF TRAFFIC
- DRUMS WITH BI-DIRECTIONAL STEADY BURN LIGHTS @ 50' CENTERS, 25' CENTERS ALONG TAPERS
- IMPACT ATTENUATOR, TEMPORARY (NON-REDIRECTIVE)
- VERTICAL PANEL

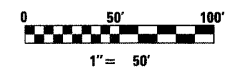

McClure LOCHNER
Engineering Associates, Inc.
RVA
Engineering & Construction, Inc.

USER NAME = .JUSERNAME.	DESIGNED - CGC	REVISED -
DRAWN - CGC	CHECKED - AM	REVISED -
DATE - 10/14/2011		

**STATE OF ILLINOIS
DEPARTMENT OF TRANSPORTATION**

MOT I-90 STAGE 3

SCALE: 1"=50' SHEET NO. OF SHEETS STA. 121+00 TO STA. 135+00

F.A.I. RTE. 90	SECTION (X2-1)R	COUNTY WINNEBAGO	TOTAL SHEETS 510	SHEET NO. 207
CONTRACT NO. 64C29			ILLINOIS FED. AID PROJECT	



EDGE LINE (SEE PERMANENT PVMT MARKING PLANS)
 EDGE LINE (SEE PERMANENT PVMT MARKING PLANS)
 PR WESTBOUND ROCKTON RD ENTRANCE RAMP
 EX WESTBOUND ROCKTON RD ENTRANCE RAMP

EDGE LINE (SEE PERMANENT PVMT MARKING PLANS)
 SKIP-DASH (SEE PERMANENT PVMT MARKING PLANS)
 TEMP PVMT MARKING LINE 4" YELLOW

MATCHLINE STATION 135+00

MATCHLINE STATION 144+00

135+00

140+00

IMPACT ATTENUATORS, RELOCATE (NON-REDIRECTIVE),
 TEST LEVEL 3 FROM STAGE 2B

RELOCATE TEMPORARY CONCRETE BARRIER FROM STAGE 2B

TEMP PVMT MARKING LINE 4" YELLOW

SKIP-DASH (SEE PERMANENT PVMT MARKING PLANS)

EDGE LINE (SEE PERMANENT PVMT MARKING PLANS)

EX EASTBOUND ROCKTON RD EXIT RAMP
 PR EASTBOUND ROCKTON RD EXIT RAMP

LEGEND

- WORK ZONE
- TEMPORARY PAVEMENT
- TEMPORARY CONCRETE BARRIER
- DIRECTION OF TRAFFIC
- DRUMS WITH BI-DIRECTIONAL STEADY BURN LIGHTS @ 50' CENTERS, 25' CENTERS ALONG TAPERS
- IMPACT ATTENUATOR, TEMPORARY (NON-REDIRECTIVE)
- VERTICAL PANEL

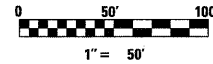

EDGE LINE (SEE PERMANENT PVMT MARKING PLANS)

EDGE LINE (SEE PERMANENT PVMT MARKING PLANS)



USER NAME = .USERNAME.	DESIGNED - CGC	REVISED -
PLOT SCALE = 50.0000' / IN.	DRAWN - CGC	REVISED -
PLOT DATE = 10/19/2011	CHECKED - AM	REVISED -
	DATE - 10/14/2011	REVISED -

STATE OF ILLINOIS
 DEPARTMENT OF TRANSPORTATION

MOT I-90 STAGE 3

SCALE: 1"=50' SHEET NO. OF SHEETS STA. 135+00 TO STA. 144+00

F.A.I. RTE.	SECTION	COUNTY	TOTAL SHEETS	SHEET NO.
90	(X2-1)R	WINNEBAGO	510	208
				CONTRACT NO. 64C29
ILLINOIS FED. AID PROJECT				



IMPACT ATTENUATORS, RELOCATE
(FULLY-REDIRECTIVE), TEST LEVEL 3
NARROW FROM STAGE 2B

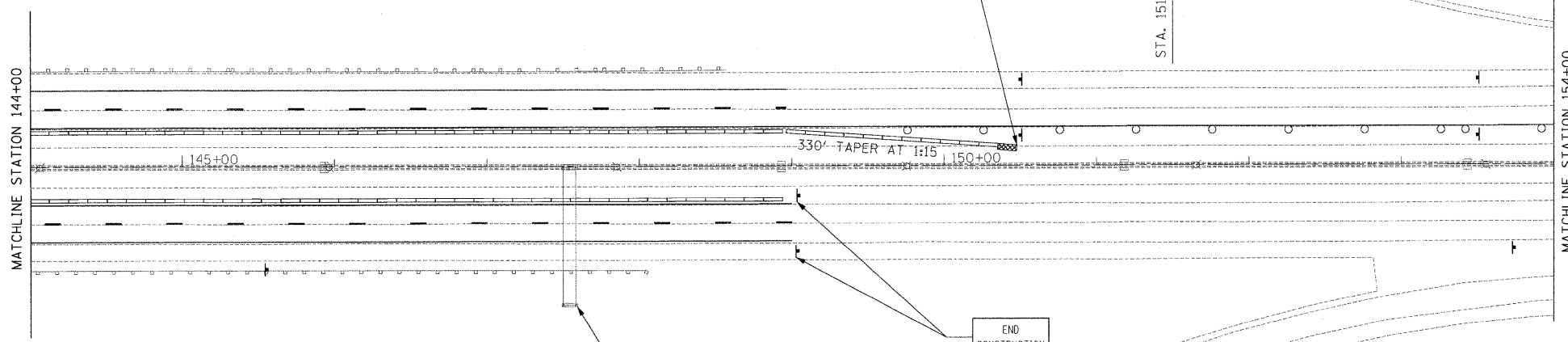

LEGEND

- WORK ZONE
- TEMPORARY PAVEMENT CONSTRUCTED IN PRESTAGE
- TEMPORARY CONCRETE BARRIER
- DIRECTION OF TRAFFIC
- DRUMS WITH BI-DIRECTIONAL STEADY BURN LIGHTS @ 50' CENTERS, 25' CENTERS ALONG TAPERS
- IMPACT ATTENUATOR, TEMPORARY
- VERTICAL PANEL
- TYPE III BARRICADE WITH FLASHING LIGHTS

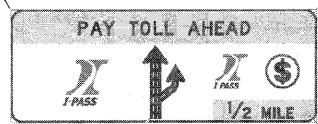

PROPOSED SIGN PANEL
RELOCATED FROM BRIDGE

END
CONSTRUCTION
G20-2a(0)-6024
STA 136+20

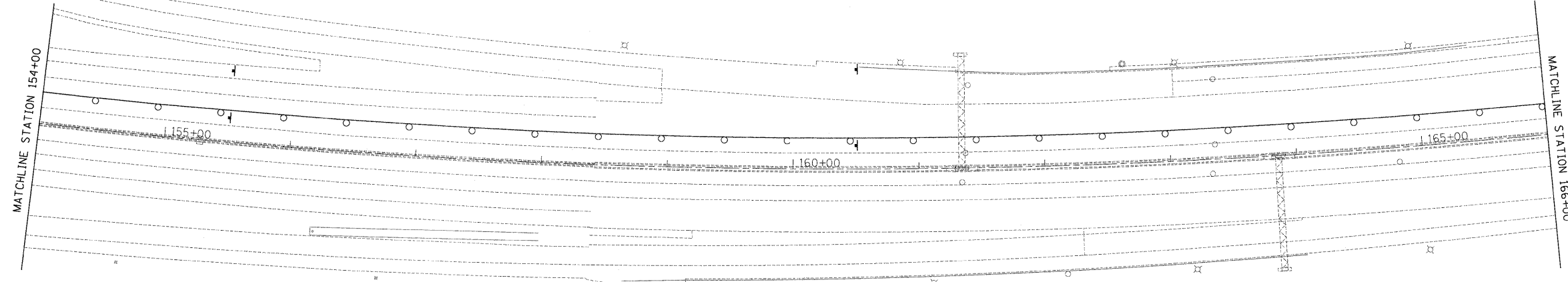

NOTE:
TRAFFIC CONTROL DEVICES, ADVANCE WARNING SIGNS,
AND TEMPORARY EDGE LINE TO REMAIN FROM STAGE
2B SOUTH OF STA. 151+50.00

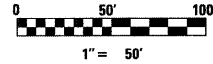

USER NAME = .USERNAME.	DESIGNED - CGC	REVISED -
PLOT SCALE = 50.0000' / IN.	DRAWN - CGC	REVISED -
PLOT DATE = 10/19/2011	CHECKED - AM	REVISED -
	DATE - 10/14/2011	REVISED -

**STATE OF ILLINOIS
DEPARTMENT OF TRANSPORTATION**

MOT I-90 STAGE 3

SCALE: 1"=50' SHEET NO. OF SHEETS STA. 144+00 TO STA. 154+00

F.A.I. RTE.	SECTION	COUNTY	TOTAL SHEETS	SHEET NO.
90	(X2-1R)	WINNEBAGO	510	209
CONTRACT NO. 64C29			ILLINOIS FED. AID PROJECT	

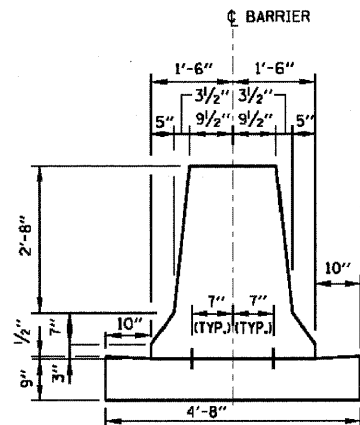

CONCRETE BARRIER, DOUBLE FACE, 42"
CONCRETE BARRIER BASE

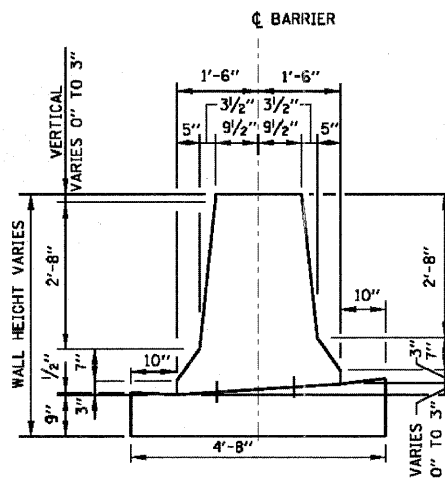

CONCRETE BARRIER,
DOUBLE FACE, VARIABLE HEIGHT
CONCRETE BARRIER BASE, VARIABLE HEIGHT

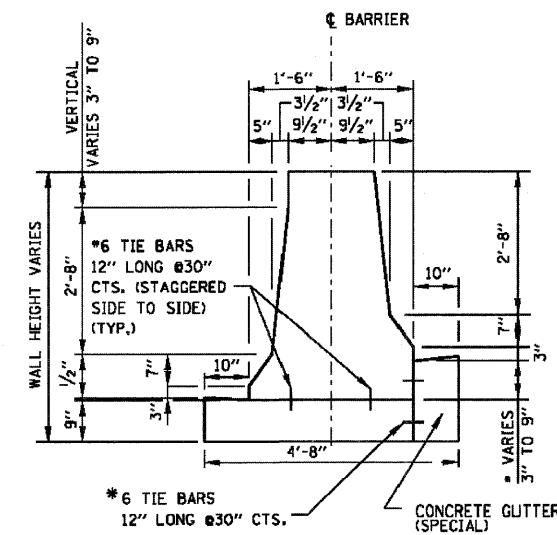

* WHEN 6" OR GREATER ADD TOP TIE BAR.

NOTES:

- 1" DEEP CONTRACTION JOINTS SHALL BE CONSTRUCTED IN THE CONCRETE BARRIER WALL AND IN THE CONCRETE BARRIER BASE. CONTRACTION JOINTS SHALL ALSO BE CONSTRUCTED AT BOTH SIDES OF ALL DRAINAGE STRUCTURES. MAXIMUM JOINT SPACING SHALL BE 20'
- THE FORMING OF CONTRACTION JOINTS SHALL BE DONE WITH AN APPROVED FINISHING TOOL AT THE DISCRETION OF THE ENGINEER SUBJECT TO THE SATISFACTORY CONTROL OF CRACKING. THE SAWING OF CONTRACTION JOINTS IN THE CONCRETE BARRIER WALL SHALL NOT BE PERMITTED.
- GUTTER PROFILE IN THE VICINITY OF SAG VERTICAL CURVES, ALONG FLAT GRADES AND AT THE MEETING OF PROPOSED AND EXISTING GUTTER, SHALL BE CAREFULLY CONTROLLED AND FIELD ADJUSTED IF NECESSARY TO ENSURE POSITIVE DRAINAGE AND AVOID PONDING.
- IN AREAS OF RELATIVELY FLAT LONGITUDINAL PROFILE GRADES, THE 3" VERTICAL DIMENSION AT THE BOTTOM OF THE BARRIER CAN VARY FROM 2" TO 3 1/4" TO CREATE AN ACCEPTABLE LONGITUDINAL GRADE IN THE GUTTER.
- TIE BARS ARE INCIDENTAL TO THE VARIOUS BARRIER & GUTTER ITEMS AND SHALL BE EPOXY COATED.
- WHEN ELECTRICAL OR ITS CONDUITS ARE REQUIRED THEY SHALL BE LOCATED IN THE BARRIER BASE OR IN THE EARTH BELOW THE BASE.
- WHEN VARIABLE HEIGHT VERTICAL DIFFERENTIAL EXCEEDS 9" SEE PLAN DETAIL.

APPROVED *Jeff Staley* DATE 10-15-2007
CHIEF ENGINEER



DATE	REVISIONS

CONCRETE BARRIER BASE AND
CONCRETE BARRIER, DOUBLE FACE,
42" AND VARIABLE HEIGHT
STANDARD C5-00



USER NAME = USERNAME...
DESIGNED - AM
DRAWN - ESC
CHECKED - AM
DATE - 10/14/2011
PLOT SCALE = 10.0000' / IN.
PLOT DATE = 10/19/2011

REVISED -
REVISED -
REVISED -
REVISED -

STATE OF ILLINOIS
DEPARTMENT OF TRANSPORTATION

CONCRETE BARRIER BASE AND CONCRETE BARRIER,
DOUBLE FACE, 42" AND VARIABLE HEIGHT

SCALE: NTS SHEET NO. OF SHEETS STA. TO STA.

F.A.I. RTE.	SECTION	COUNTY	TOTAL SHEETS	SHEET NO.
90	(X2-1)R	WINNEBAGO	510	210
CONTRACT NO. 64C29				
ILLINOIS FED. AID PROJECT				

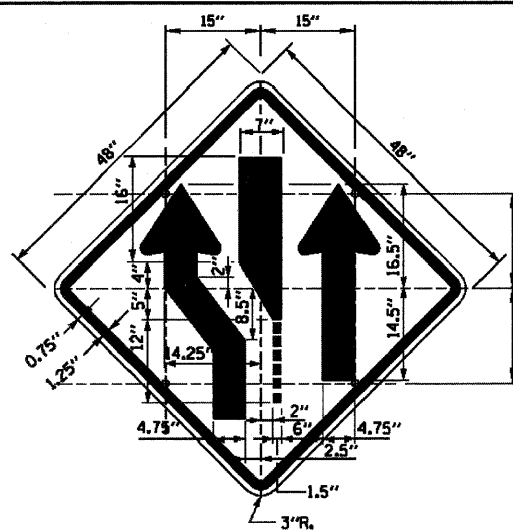

SIGN TS-1 (O)

COLOR: BACKGROUND - FLUORESCENT ORANGE (O)
 BORDER AND SYMBOL - BLACK
 SIZE: 48"x48"
 MOUNTING HOLES: 7/8" DIA., 4 HOLES SPACED AS SHOWN
 NOTE: SIGN TS-1L IS SHOWN; REVERSE SYMBOL FOR SIGN TS-1R

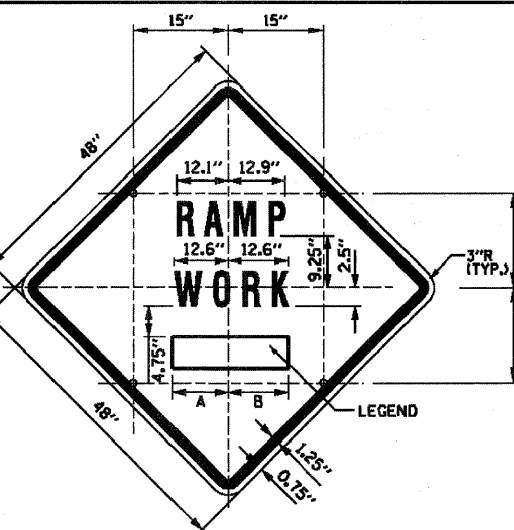

SIGN TS-2 (O)

COLOR: BACKGROUND - FLUORESCENT ORANGE (O)
 BORDER AND SYMBOL - BLACK
 SIZE: 48"x48"
 LETTERING: 7" FEDERAL SERIES D
 MOUNTING HOLES: 7/8" DIA., 4 HOLES SPACED AS SHOWN

SIGN NO.	LEGEND	A	B
TS-2A	AHEAD	15.50"	15.50"
TS-2B	500 FT	14.25"	15.13"
TS-2C	1000 FT	14.88" L2	15.75" L2
TS-2D	1500 FT	14.88" L2	15.75" L2
TS-2E	1/2 MILE	15.75" L3	15.75" L3
TS-2F	1 MILE	13.06"	13.06"

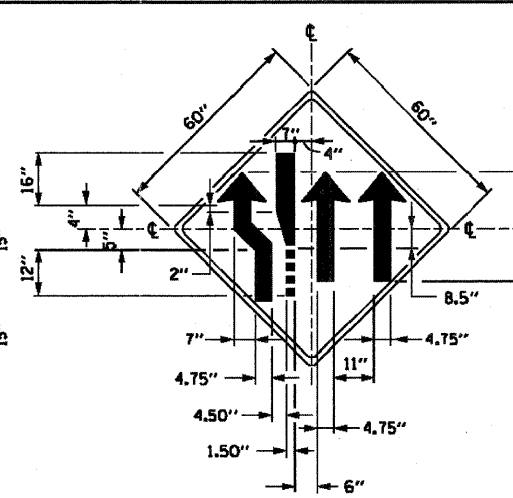

SIGN TS-1CL (O)

COLOR: BACKGROUND - FLUORESCENT ORANGE (O)
 BORDER AND SYMBOL - BLACK
 (NON-REFLECTORIZED)

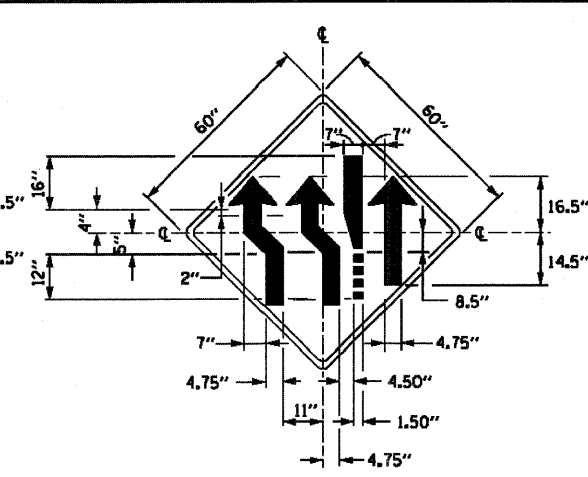

SIGN TS-1CR (O)

COLOR: BACKGROUND - FLUORESCENT ORANGE (O)
 BORDER AND SYMBOL - BLACK
 (NON-REFLECTORIZED)

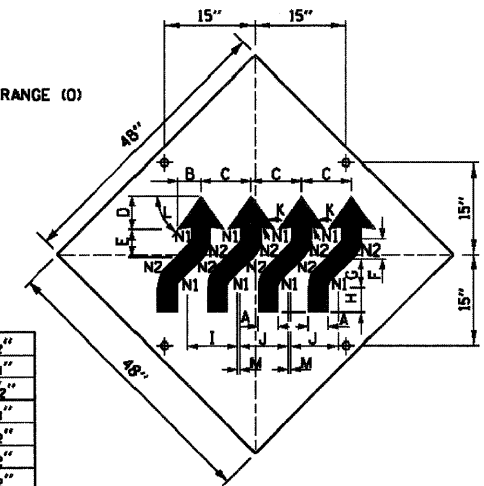

SIGN WI-4dR (O)

COLOR: BACKGROUND, FLUORESCENT ORANGE (O)
 TYPE A REFLECTIVE SHEETING PER STANDARD SPECIFICATIONS (#A)
 BORDER AND LETTERS - BLACK
 SIZE: 48"x48"
 MOUNTING HOLES: 7/8" DIA., 4 HOLES SPACED AS SHOWN.

A	4 1/2"
B	5 3/4"
C	12 1/2"
D	7 3/4"
E	6 1/2"
F	4 1/2"
G	6 1/2"
H	6"
I	12 3/4"
J	12"
K	45°
L	55°
M	0 3/4"
N1	2"
N2	6 1/2"

NOTES:

- ALL LETTERING IS DESIGNATED BY SIZE AND SERIES IN ACCORDANCE WITH THE LATEST EDITION OF "STANDARD ALPHABETS FOR HIGHWAY SIGNS AND PAVEMENT MARKINGS" AS PUBLISHED BY THE U.S. DEPARTMENT OF TRANSPORTATION. LETTERING SPACING SHALL BE IN ACCORDANCE WITH THIS GUIDE EXCEPT WHERE NOTED.
- SYMBOLS AND ARROWS SHALL CONFORM TO THE DETAILS SHOWN IN THE LATEST EDITION OF "STANDARD HIGHWAY SIGNS" AS PUBLISHED BY THE U.S. DEPARTMENT OF TRANSPORTATION.
- SEE THE CONTRACT REQUIREMENTS FOR ADDITIONAL NOTES AND SPECIFICATIONS.
 (O) FLUORESCENT ORANGE REFLECTIVE SHEETING PER THE STANDARD SPECIFICATIONS.
 (#A) - REFLECTIVE SHEETING PER THE STANDARD SPECIFICATIONS.
- DIMENSIONS INDICATED THUS L ARE BASED ON A REDUCTION IN STANDARD LETTERING SPACING AS SHOWN BELOW:
 L1 SPACING REDUCED BY 25%
 L2 SPACING REDUCED BY 40%
 L3 SPACING REDUCED BY 50%

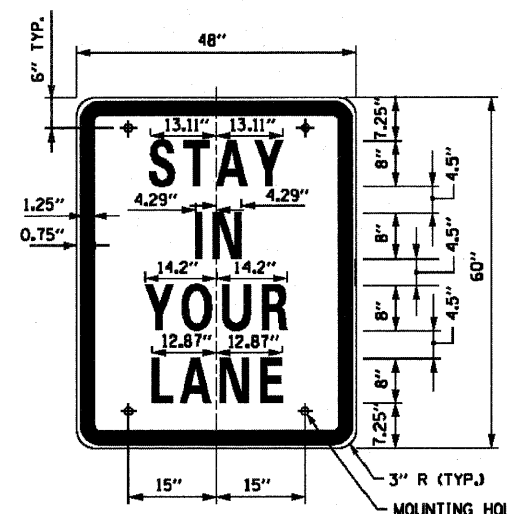

SIGN TS-3

COLOR: BACKGROUND - WHITE (REFLECTORIZED#A)
 BORDER AND LETTERS - BLACK
 SIZE: 48"x60"
 LETTERING: LEGEND - 8" FEDERAL SERIES D
 MOUNTING HOLES: 7/8" DIA., 4 HOLES, SPACED AS SHOWN

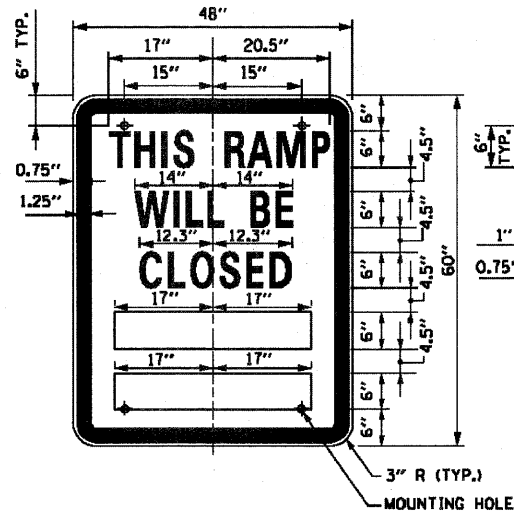

SIGN TS-4

COLOR: BACKGROUND - WHITE (REFLECTORIZED#A)
 BORDER AND LETTERS - BLACK
 SIZE: 48"x60"
 LETTERING: LEGEND - 6" FEDERAL SERIES C
 MOUNTING HOLES: 7/8" DIA., 4 HOLES, SPACED AS SHOWN

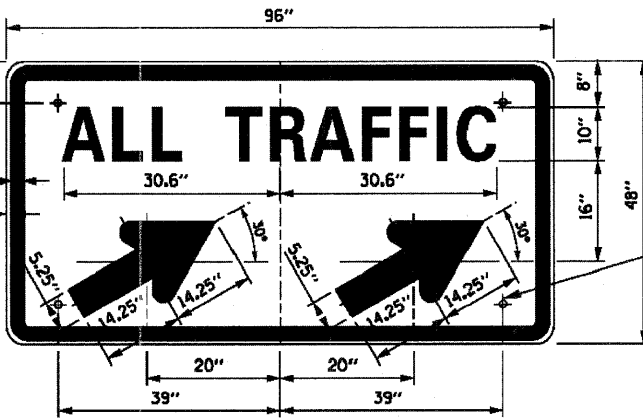

SIGN TS-5a & TS-5b

COLOR: BACKGROUND - WHITE (REFLECTORIZED#A)
 BORDER AND LETTERS - BLACK
 ARROW - BLACK
 SIZE: 96"x48"
 LETTERING: 10" FEDERAL SERIES D
 MOUNTING HOLES: 7/8" DIA., 4 HOLES, SPACED AS SHOWN
 NOTE: SIGN TS-5a IS SHOWN, SUBSTITUTE LEGEND " " FOR " " FOR SIGN TS-5b

RAMP CLOSURE ADVANCE INFORMATION SIGN

THE VARIABLE MESSAGE WITH DATES FOR THE BOTTOM TWO LINES SHALL BE DETERMINED BY THE ENGINEER AND GIVEN TO THE CONTRACTOR BEFORE THE REQUIRED FIELD ERECTION DATE.

APPROVED: *Paul Kovacs*
 DATE 5-1-2009



DATE	REVISIONS
5-1-2009	DELETED FLASHING ARROW BOARDS
1-1-2011	ADDED SIGN COLOR DESIGNATION

CONSTRUCTION SIGNS	
STANDARD E1-02	

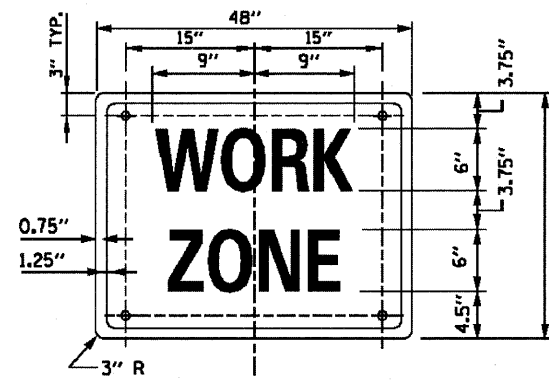

SIGN G20-I102 (O)

COLOR: BACKGROUND - FLUORESCENT ORANGE (O)
 BORDER AND LETTERS - BLACK
 SIZE: 48"x24"
 LETTERING: 6" FEDERAL SERIES C,
 MOUNTING HOLES: 7/16" DIA., 4 HOLES SPACED AS SHOWN ON SIGN G20-2A

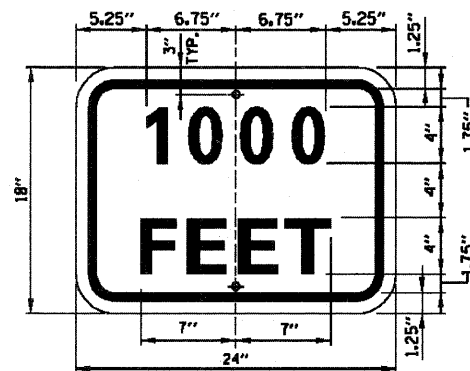

SUPPLEMENTAL PLATE (O)

COLOR: BACKGROUND - FLUORESCENT ORANGE (O)
 BORDER AND LETTERS - BLACK
 SIZE: 24"x18"
 LETTERING: 4" FEDERAL SERIES D
 MOUNTING HOLES: 7/16" DIA.

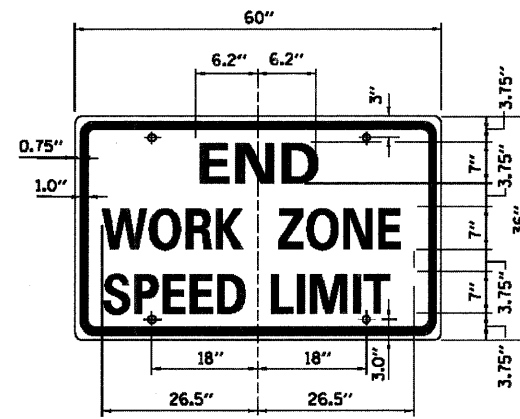

SIGN G20-I103 (O)

COLOR: BACKGROUND - FLUORESCENT ORANGE (O)
 BORDER AND LETTERS - BLACK
 SIZE: 60"x36"
 LETTERING: 6" FEDERAL SERIES C,
 MOUNTING HOLES: 7/16" DIA., 4 HOLES SPACED AS SHOWN

"WORK ZONE"
 W21-1115(O)-3618
 (BLACK ON FLUORESCENT
 ORANGE) (O)

"SPEED LIMIT XX"
 R2-1-3648
 (BLACK ON WHITE) (*A)
 * 45 OR 55 MPH

"XXX FINE MINIMUM"
 R2-1106
 (BLACK ON WHITE) (*A)

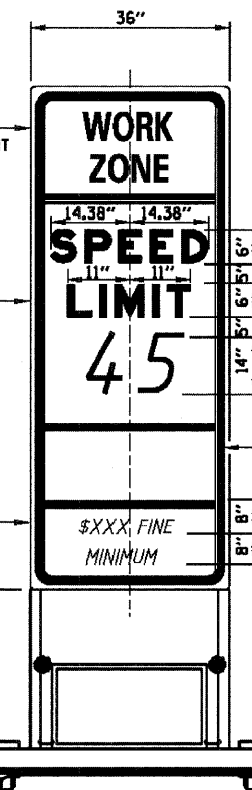

"BEGINS" (W21-1113), OR
 "RESUMES" (W21-1114)
 (O) 3612
 (BLACK ON
 FLUORESCENT
 ORANGE) (O)

WORK ZONE SPEED LIMIT
 SIGN ASSEMBLY

GENERAL NOTES:

- ALL LETTERING IS DESIGNATED BY SIZE AND SERIES IN ACCORDANCE WITH THE LATEST EDITION OF "STANDARD ALPHABETS FOR HIGHWAY SIGNS AND PAVEMENT MARKINGS" AS PUBLISHED BY THE U.S. DEPARTMENT OF TRANSPORTATION. LETTERING SPACING SHALL BE IN ACCORDANCE WITH THE GUIDE EXCEPT WHERE NOTED.
- SYMBOLS AND ARROWS SHALL CONFORM TO THE DETAILS SHOWN IN THE LATEST EDITION OF "STANDARD HIGHWAY SIGNS" AS PUBLISHED BY THE U.S. DEPARTMENT OF TRANSPORTATION.
- SEE THE CONTRACT REQUIREMENTS FOR ADDITIONAL NOTES AND SPECIFICATIONS.
 (O) FLUORESCENT ORANGE REFLECTIVE SHEETING PER THE STANDARD SPECIFICATIONS.
 (*A)-REFLECTIVE SHEETING PER THE STANDARD SPECIFICATIONS.

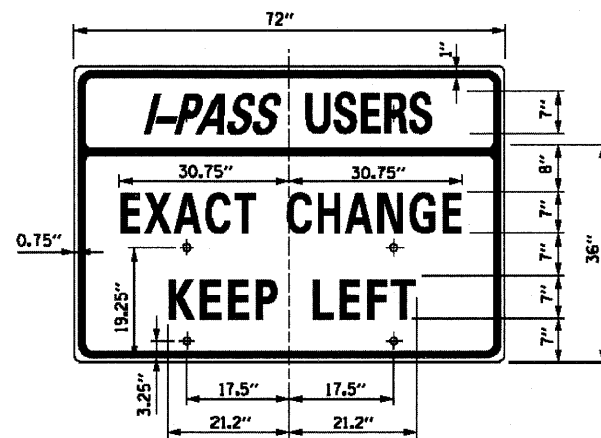

SIGN TS-7

COLOR: BACKGROUND - WHITE (REFLECTORIZED) (*A)
 BORDER AND LETTERS - BLACK
 SIZE: 72"x36"
 LETTERING: 7" FEDERAL SERIES C
 MOUNTING HOLES: 7/16" DIA., 4 HOLES SPACED AS SHOWN

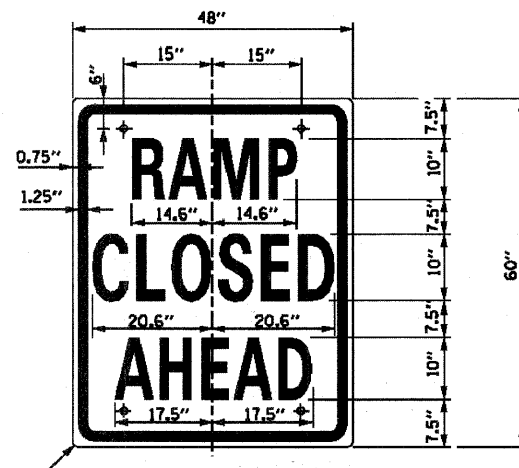

SIGN TS-9

COLOR: BACKGROUND - WHITE (REFLECTORIZED)
 BORDER AND LETTERS - BLACK
 SIZE: 48"x60"
 LETTERING: 10" FEDERAL SERIES C
 MOUNTING HOLES: 7/16" DIA., 4 HOLES SPACED AS SHOWN

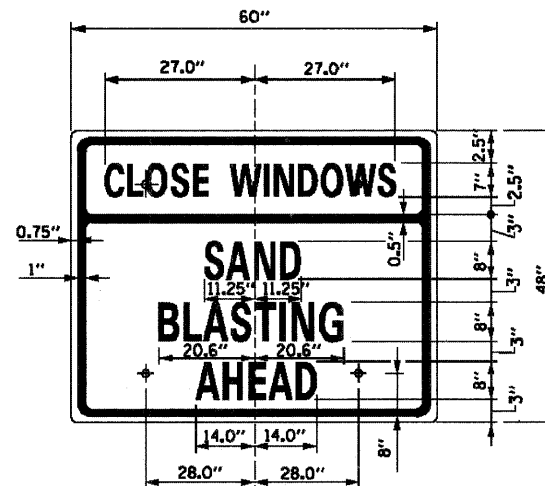

SIGN TS-10 (O)

COLOR: BACKGROUND - FLUORESCENT ORANGE (O)
 BORDER AND LETTERS - BLACK
 SIZE: 60"x48"
 LETTERING: 8" FEDERAL SERIES C, 7" FEDERAL SERIES B
 MOUNTING HOLES: 7/16" DIA., 4 HOLES SPACED AS SHOWN

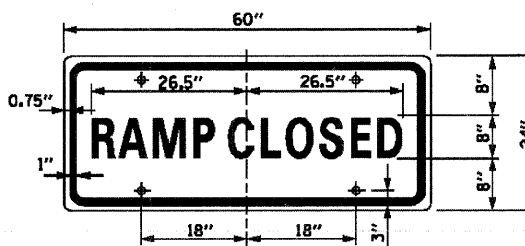

SIGN TS-6

COLOR: BACKGROUND - WHITE (REFLECTORIZED)
 BORDER AND LETTERS - BLACK
 SIZE: 60"x24"
 LETTERING: 8" FEDERAL SERIES C
 MOUNTING HOLES: 7/16" DIA., 4 HOLES SPACED AS SHOWN

APPROVED: *Paul Kovacs* DATE 5-1-2009
 CIVIL ENGINEER

SHEET 2 OF 2



CONSTRUCTION SIGNS

STANDARD E1-02

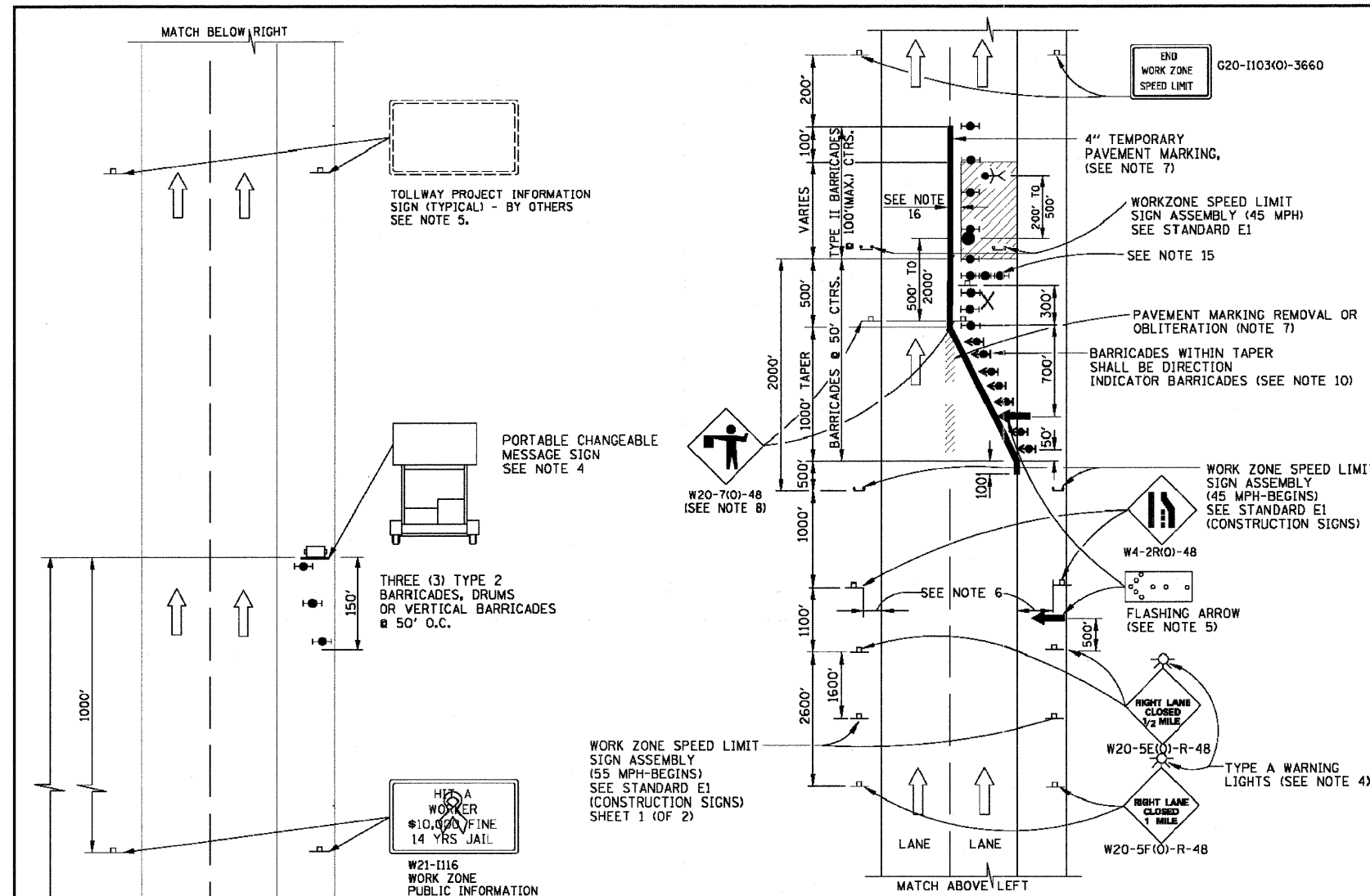

LANE CLOSURE NOTES:

- IF CLOSURES ARE EXPECTED TO PRODUCE TRAFFIC BACKUPS EXTENDING BEYOND THE FIRST WARNING SIGN SHOWN ON THE DETAILS, ADDITIONAL UPSTREAM SIGNS SHALL BE PLACED SO THAT THE TRAFFIC CONTROL ZONE ENCOMPASSES THE ANTICIPATED BACKUP ZONE.
- LONGITUDINAL DIMENSIONS MAY BE ADJUSTED SLIGHTLY TO FIT FIELD CONDITIONS.
- THESE DETAILS ALSO APPLY TO OPPOSITE HAND LANE CLOSURES BY CHANGING SIGN LEGENDS AND ARROW DIRECTIONS TO INDICATE THE APPROPRIATE CLOSURE.
- FOR NIGHT TIME CLOSURES, ONE TYPE A WARNING LIGHT SHALL BE INSTALLED ABOVE EACH OF THE 1 MILE AND 1/2 MILE ADVANCE WARNING SIGNS. FOR DAYLIGHT-ONLY CLOSURES, THE LIGHTS MAY BE OMITTED.
- FOR ANY LANE CLOSURE, FLASHING ARROW BOARDS SHALL BE REQUIRED AND IN OPERATION AT ALL TIMES. THE FLASHING ARROW BOARD IN ADVANCE OF THE TAPER SHALL BE PROTECTED WITH THREE TYPE II BARRICADES AT 50' O.C.
- CONSTRUCTION SIGNS SHALL GENERALLY BE POST-MOUNTED OR ATTACHED TO PORTABLE SUPPORTS AND SHALL BE INSTALLED 8' TO 12' FROM ADJACENT TRAVEL LANE WHEREVER POSSIBLE. IN NO CASE SHALL SIGNS BE LOCATED TO PROVIDE LESS THAN 2' CLEARANCE BETWEEN EDGE OF SIGN AND ADJACENT TRAVEL LANE.
- PAVEMENT MARKING TAPE AND REMOVAL OR OBLITERATION OF EXISTING MARKINGS SHALL BE REQUIRED WHEN THE CLOSURE TIME EXCEEDS FOUR DAYS. THIS WORK SHALL BE MEASURED AND PAID FOR SEPARATELY.
- WHEN A FLAGGER IS NOT ON STATION, THE FLAGGER SIGN SHALL BE PROMPTLY REMOVED, COVERED OR TURNED TO FACE AWAY FROM TRAFFIC. FLAGGER SIGNS SHALL BE MOVED AS NECESSARY TO MAINTAIN THE REQUIRED SPACING BETWEEN THE SIGNS AND THE WORKERS IN EACH SEPARATE WORK ACTIVITY, PER THE TOLLWAY SUPPLEMENTAL SPECIFICATIONS.
- WHENEVER WORKERS ARE PRESENT AND WITHIN 12' OR LESS TO MOVING TRAFFIC, WORK ZONE SPEED LIMIT SIGN ASSEMBLIES SHALL BE PLACED ADJACENT TO THE OPEN TRAFFIC LANE(S). WORK ZONE SPEED SIGNS SHALL BE MOVED AS NECESSARY TO MAINTAIN THE REQUIRED SPACING BETWEEN SIGNS AND THE WORKERS IN EACH SEPARATE WORK ACTIVITY PER THE TOLLWAY SUPPLEMENTAL SPECIFICATIONS.
- DIRECTION INDICATOR BARRICADES SHALL BE USED IN LANE TAPERS.
- FOR CLOSURES OTHER THAN SHORT TERM (SUNRISE TO ONE HOUR BEFORE SUNSET), THE MINIMUM HEIGHT OF THE SIGN FROM SHOULDER ELEVATION SHALL BE 7'-0".
- CONES MAY BE USED IN LIEU OF BARRICADES IN THE BUFFER AND WORK AREAS, WHEN THE CLOSURE IS FOR MAINTENANCE OPERATIONS.
- BARRICADES ARE TO BE LOCATED AT JOINT LINE WHEN WORK AREA EXTENDS UP TO JOINT UNLESS OTHERWISE SHOWN ON THE PLANS.
- SEE MAINTENANCE OF TRAFFIC DRAWINGS FOR ADDITIONAL SIGNING IN THIS AREA.
- CHECK BARRICADES SHALL BE PLACED IN THE MIDDLE OF THE CLOSED LANE AND AT THE SHOULDER AT 1000 FOOT CENTERS.
- A 1'-0" MINIMUM/2'-0" DESIRABLE SHY DISTANCE SHALL BE PROVIDED, MEASURED BETWEEN EDGE OF PAVEMENT LANE MARKING TO THE EDGE OF THE TRAFFIC CONTROL DEVICE.

ONE-LANE CLOSURE

ADVANCE SIGNAGE NOTES:

- THE ADVANCE SIGNAGE SHOWN ON THIS STANDARD SHALL APPLY ANY TIME THE CONTRACTOR CLOSES ONE OR MORE LANES, OR IS REQUIRED TO SHIFT THE LANE ALIGNMENT. THE "ROAD WORK AHEAD" OR "ROAD CONSTRUCTION AHEAD" SIGNS, WORK ZONE PUBLIC INFORMATION SIGNS AND PORTABLE CHANGEABLE MESSAGE ARE STATIONARY.
- THE ROAD CONSTRUCTION AHEAD SIGN (W20-1A, WITH W16-3a SUPPLEMENTAL PLATE) OR ROAD WORK AHEAD SIGN (W20-1, WITH WITH W16-3A SUPPLEMENTAL PLATE) SHALL BE LOCATED UP TO 5 MILES IN ADVANCE OF THE PROJECT LIMITS, WITH THE LOCATION BEING DETERMINED BY THE ENGINEER.
- THE WORK ZONE INFORMATION SIGN IS 60" WIDE BY 48" HIGH. THE CONTRACTOR SHALL OBTAIN THE CAMERA-READY ARTWORK REQUIRED FOR THE SIGN MESSAGE BY CONTACTING IDOT'S CENTRAL BUREAU OF OPERATIONS.
- THE PORTABLE CHANGEABLE MESSAGE SIGN SHALL BE USED TO DISPLAY THE STATUS OF LANE WITHIN THE CONTRACT LIMITS. THE PRIMARY MESSAGES SHALL BE: "RIGHT LANE(S) CLOSED" / "X MILES AHEAD", "LEFT LANE(S) CLOSED" / "X MILES AHEAD", "LANE(S) SHIFT" / "X MILES AHEAD", "ALL LANES OPEN". THE PORTABLE CHANGEABLE MESSAGE SIGN MAY BE MOVED TO THE MEDIAN SHOULDER WHEN THE LANE CLOSURES ARE ON THE LEFT, PROVIDED THE EXISTING SHOULDER WIDTH IS ADEQUATE.
- THE TOLLWAY WILL FURNISH AND INSTALL STATIC PROJECT INFORMATION SIGNS IN ADVANCE, THROUGH AND AT THE END OF THE WORK ZONE. THESE SIGNS WILL BE INSTALLED ALONG THE OUTSIDE SHOULDER WITH THE ADVANCE SIGNS LOCATED BEYOND THE PORTABLE CHANGEABLE MESSAGE SIGN. THE ENGINEER AND CONTRACTOR SHALL COORDINATE WITH THE TOLLWAY REGARDING THE LOCATION OF THESE SIGNS AND NOTIFY THE TOLLWAY OF ANY DAMAGE TO THE SIGNS OR SUPPORTS.

SYMBOLS

- ARROW BOARD
- WORK AREA
- SIGN
- DIRECTION INDICATOR BARRICADE WITH STEADY BURN MONODIRECTIONAL LIGHT
- TYPE II BARRICADE, DRUM, OR VERTICAL BARRICADE WITH STEADY BURN MONODIRECTIONAL LIGHT
- FLAGGER WITH TRAFFIC CONTROL SIGN
- WORKER
- LANE CLOSED

SHEET 1 OF 2



DATE	REVISIONS
5-1-2009	CHANGED TRAFFIC CONTROL DIMENSIONS UPDATED ROADWAY SIGNAGE
1-1-2011	CHANGED SYMBOL DESIGNATION, REVISED NOTES

LANE CLOSURE DETAILS
STANDARD E2-02

APPROVED: *Paul Kovacs* CHIEF ENGINEER DATE 5-1-2009

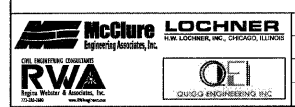

USER NAME = .USERNAME.	DESIGNED - AM	REVISED -
PLOT SCALE = 10,0000' / IN.	DRAWN - ESC	REVISED -
PLOT DATE = 10/19/2011	CHECKED - AM	REVISED -
	DATE - 10/14/2011	REVISED -

STATE OF ILLINOIS
DEPARTMENT OF TRANSPORTATION

LANE CLOSURE DETAILS 1

SCALE: NTS SHEET NO. OF SHEETS STA. TO STA.

F.A.I. RTE. 90	SECTION (X2-1R)	COUNTY WINNEBAGO	TOTAL SHEETS 510	SHEET NO. 213
CONTRACT NO. 64C29				
ILLINOIS FED. AID PROJECT				

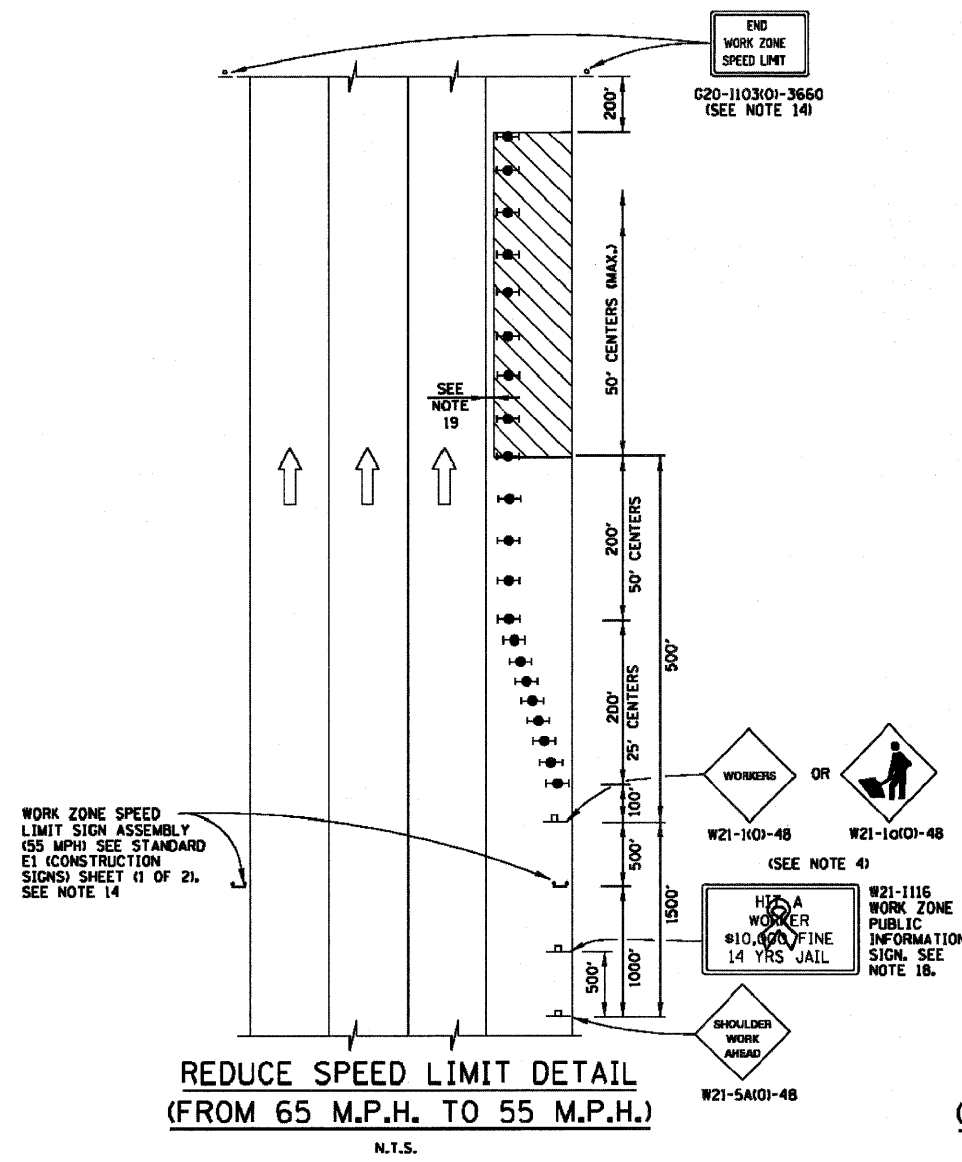

**REDUCE SPEED LIMIT DETAIL
(FROM 65 M.P.H. TO 55 M.P.H.)**

N.T.S.

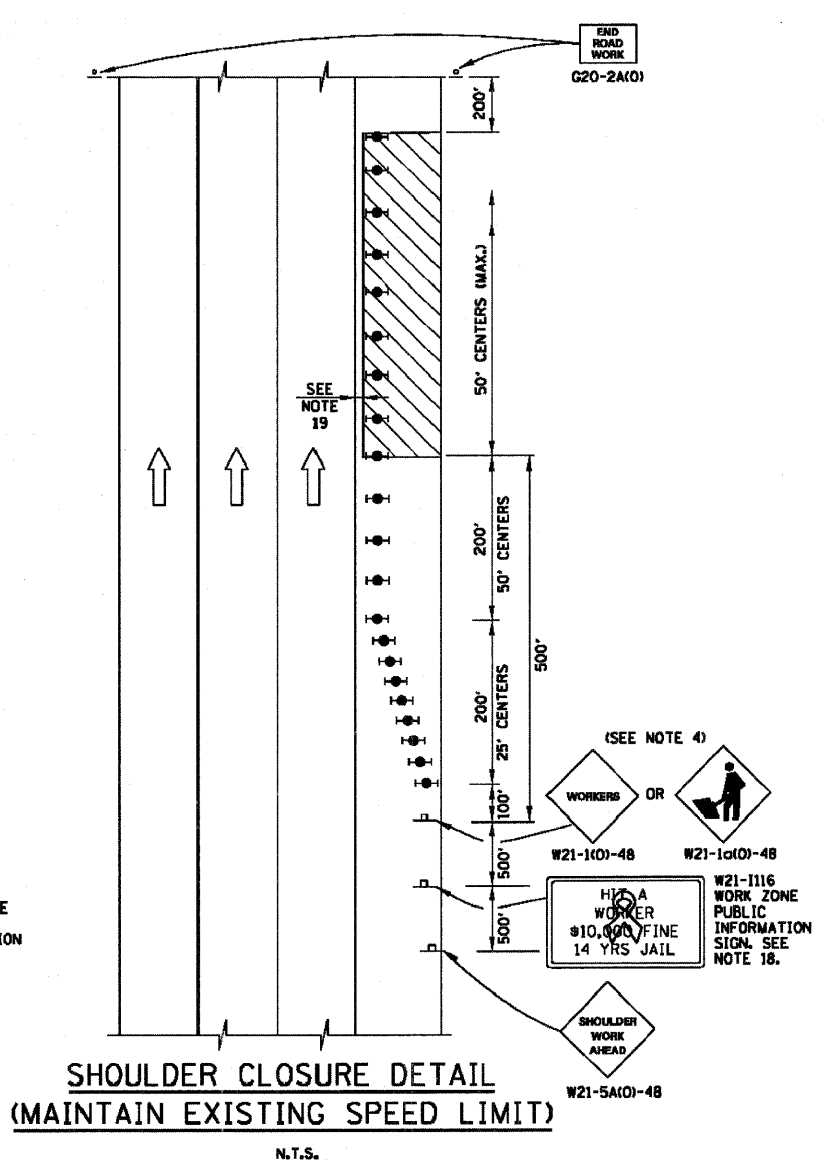

**SHOULDER CLOSURE DETAIL
(MAINTAIN EXISTING SPEED LIMIT)**

N.T.S.

GENERAL NOTES:

1. THE SHOULDER SHALL BE CLOSED WHEN A WORK ACTIVITY REQUIRING 15 OR MORE MINUTES IS PERFORMED AT A DISTANCE WHICH IS LESS THAN 15 FEET BUT NO CLOSER THAN 2 FEET THE EDGE OF PAVEMENT.
2. THE ADJACENT EXTERIOR LANE SHALL BE CLOSED WHEN WORK IS PERFORMED WITHIN 2 FEET FROM THE EDGE OF PAVEMENT.
3. THE CHANNELIZING DEVICES WHICH SEPARATE THE WORK SPACE FROM THE ADJACENT TRAVEL LANE SHALL BE SPACED AT 25' FOR (200 FEET) AND AT A MAXIMUM OF 50' FOR ALL ADDITIONAL DEVICES.
4. WHEN THE WORKSITE IS UNATTENDED, SUBSTITUTE - "SHOULDER WORK AHEAD" SIGN FOR THE SECOND SIGN.
5. WORKER SIGNS OR SHOULDER WORK SIGNS AND CHANNELIZATION DEVICES ARE PLACED ONLY ON THE SIDE OF THE ROADWAY ON WHICH THE ACTIVITY IS PERFORMED.
6. FOR SHOULDER CLOSURE EXTENDING OVERNIGHT, BARRICADE TYPE II WITH STEADY BURNING LIGHT, TYPE C SHALL BE USED.
7. FOR SHORT TERM CLOSURE (SUNRISE TO ONE HOUR BEFORE SUNSET) NOT EXTENDING INTO DARKNESS, CONES MAY BE USED.
8. ONE WORK ZONE SPEED LIMIT SIGN ASSEMBLY (55 MPH - BEGINS) SHALL BE PLACED AT A DISTANCE OF 500' TO 2,500' MAXIMUM IN ADVANCE OF WORKERS THROUGHOUT THE SHOULDER CLOSURE. MOVING OPERATIONS MAY REQUIRE CONTINUOUS ADJUSTMENT OF THE SIGN ASSEMBLY LOCATION TO MAINTAIN THE ABOVE INTERVAL.
9. AN ADDITIONAL SIGN ASSEMBLY SHALL BE PLACED 500' BEYOND THE LAST ENTRANCE RAMP FOR EACH INTERCHANGE THAT FALLS WITHIN THE 2,500'.
10. THE SIGN ASSEMBLY SHALL BE PLACED NO CLOSER THAN 500' TO ANY OTHER SIGN.
11. THE SIGN ASSEMBLY SHALL NOT BE UTILIZED WHEN WORKERS ARE BEHIND A TEMPORARY (MOVABLE BARRIER) WALL.
12. THE WORK ZONE SPEED LIMIT SIGNS AND SIGN ASSEMBLY SHALL BE PROMPTLY REMOVED OR COVERED WHEN WORKERS ARE NOT PRESENT OR CLOSE TO MOVING TRAFFIC.
13. ALL CONFLICTING SPEED LIMIT SIGNS SHALL BE COVERED OR REMOVED.
14. "END WORK ZONE SPEED LIMIT" SIGNS SHALL BE IN PLACE ONLY WHEN THE EXISTING POSTED SPEED > 55MPH.
15. FOR SHOULDER REPAIRS OR REPLACEMENT THE CHANNELIZING DEVICES SHALL BE PLACED AT THE EDGE OF PAVEMENT WHENEVER THE WORK ACTIVITIES RESULT IN A DROPOFF AT THE EDGE OF PAVEMENT.
16. "WORK ZONE SPEED LIMIT" SIGNS SHALL BE IN PLACE ONLY WHEN THE EXISTING POSTED SPEED > 55MPH.
17. ANY UNATTENDED OBSTACLE OR EXCAVATION LEFT ON THE SHOULDER OVERNIGHT SHALL BE PROTECTED BY TEMPORARY CONCRETE BARRIER.
18. THE WORK ZONE INFORMATION SIGN IS 60" WIDE BY 48" HIGH. THE CONTRACTOR SHALL OBTAIN THE CAMERA-READY ARTWORK REQUIRED FOR THE SIGN MESSAGE BY CONTACTING IDOT'S CENTRAL BUREAU OF OPERATIONS.
19. A 1'-0" MINIMUM/2'-0" DESIRABLE SHY DISTANCE SHALL BE PROVIDED, MEASURED BETWEEN EDGE OF PAVEMENT LANE MARKING TO THE EDGE OF THE TRAFFIC CONTROL DEVICE.

SYMBOLS

- WORK AREA
- SIGN
- TYPE II BARRICADE, DRUM, OR VERTICAL BARRICADE WITH STEADY BURN MONODIRECTIONAL LIGHT



DATE	REVISIONS
5-1-2009	MODIFIED SHOULDER CLOSURE DETAILS - MAINTAIN EXISTING SPEED LIMIT - SPEED REDUCTION - MOVED "TEMPORARY GORE DETAILS" TO E5
1-1-2011	CHANGED SYMBOL DESIGNATION - REVISED NOTES

SHOULDER CLOSURE DETAILS
STANDARD E3-02

APPROVED *Paul Kovacs* CHIEF ENGINEER DATE 5-1-2009

THIS PLAN HAS BEEN PREPARED TO COMPLY WITH THE PROVISIONS OF THE NPDES PERMIT NUMBER ILR10, ISSUED BY THE ILLINOIS ENVIRONMENTAL PROTECTION AGENCY ON AUGUST 11, 2008 FOR STORM WATER DISCHARGES FROM CONSTRUCTION SITE ACTIVITIES. THIS PLAN HAS ALSO BEEN PREPARED TO COMPLY WITH THE PROVISIONS OF NPDES PERMIT NUMBER ILR40 FOR DISCHARGES FROM SMALL MUNICIPAL SEPARATE STORM SEWER SYSTEMS IF CHECKED BELOW.

NPDES PERMIT ASSOCIATED WITH THIS PROJECT:

- ILR10
- ILR40 PERMIT NO.

I CERTIFY UNDER PENALTY OF LAW THAT THIS DOCUMENT AND ALL ATTACHMENTS WERE PREPARED UNDER MY DIRECTION OR SUPERVISION IN ACCORDANCE WITH A SYSTEM DESIGNED TO ASSURE THAT QUALIFIED PERSONNEL PROPERLY GATHERED AND EVALUATED THE INFORMATION SUBMITTED. BASED ON MY INQUIRY OF THE PERSON OR PERSONS WHO MANAGE THE SYSTEM, OR THOSE PERSONS DIRECTLY RESPONSIBLE FOR GATHERING THE INFORMATION, THE INFORMATION SUBMITTED IS, TO THE BEST OF MY KNOWLEDGE AND BELIEF, TRUE, ACCURATE AND COMPLETE. I AM AWARE THAT THERE ARE SIGNIFICANT PENALTIES FOR SUBMITTING FALSE INFORMATION, INCLUDING THE POSSIBILITY OF FINE AND IMPRISONMENT FOR KNOWING VIOLATIONS.

ERIC S. THERKILDSEN
PRINT NAME

SIGNATURE

DEPUTY DIRECTOR OF HIGHWAYS
ACTING REGION TWO ENGINEER
TITLE

DATE

ILLINOIS DEPARTMENT OF TRANSPORTATION

I. SITE DESCRIPTION

A. THE FOLLOWING IS A DESCRIPTION OF THE PROJECT LOCATION:

THE PROJECT IS LOCATED ON FAI 90 (I-90) FROM WISCONSIN STATE LINE TO ROCKTON ROAD.

B. THE FOLLOWING IS A DESCRIPTION OF THE CONSTRUCTION ACTIVITY WHICH IS THE SUBJECT OF THIS PLAN:

THE RECONSTRUCTION OF EXISTING LANES ALONG WITH ADDITIONAL LANES TO MATCH THE TOLLWAY SECTION OF 3 LANES IN EACH DIRECTION WITH PAVED INSIDE AND OUTSIDE SHOULDERS SEPARATED BY A CONCRETE MEDIAN BARRIER. THE RAMPS ON THE NORTH SIDE OF ROCKTON ROAD WILL BE COMPLETELY RECONSTRUCTED. DRY RUN CREEK (SN 101-0001 & 0002) BRIDGES AND WILL BE REPLACED WITH A WIDER BRIDGE. THE TRIBUTARY TO DRY RUN CREEK (SN 101-1031 & 1095) CULVERTS WILL BE REPLACED.

C. THE FOLLOWING IS A DESCRIPTION OF THE INTENDED SEQUENCE OF MAJOR ACTIVITIES WHICH WILL DISTURB SOILS FOR MAJOR PORTIONS OF THE CONSTRUCTION SITE, SUCH AS GRUBBING, EXCAVATING AND GRADING:

STAGE I - MOVE TRAFFIC TO EASTBOUND LANES AND RECONSTRUCT WESTBOUND LANES. REMOVE AND REPLACE STRUCTURE UNDER WESTBOUND LANES OVER DRY RUN CREEK & BOX CULVERT UNDER WESTBOUND LANES OVER TRIBUTARY TO DRY RUN CREEK. RECONSTRUCT ENTRANCE AND EXIT RAMPS FOR WESTBOUND TRAFFIC.

STAGE II - MOVE TRAFFIC TO WESTBOUND LANES AND RECONSTRUCT EASTBOUND LANES. REMOVE AND REPLACE STRUCTURE UNDER EASTBOUND LANES OVER DRY RUN CREEK & BOX CULVERT UNDER EASTBOUND LANES OVER TRIBUTARY TO DRY RUN CREEK. RECONSTRUCT ENTRANCE AND EXIT RAMPS FOR EASTBOUND TRAFFIC.

D. THE TOTAL AREA OF THE CONSTRUCTION SITE IS ESTIMATED TO BE 72.2 ACRES.

THE TOTAL AREA OF THE SITE THAT IS ESTIMATED WILL BE DISTURBED BY EXCAVATION, GRADING OR OTHER ACTIVITIES IS 72.2 ACRES.

E. THE FOLLOWING IS A WEIGHTED AVERAGE OF THE RUNOFF COEFFICIENT FOR THIS PROJECT AFTER CONSTRUCTION ACTIVITIES ARE COMPLETED: C=0.65

F. THE FOLLOWING IS A DESCRIPTION OF THE SOIL TYPES AT THE PROJECT SITE FOLLOWED BY INFORMATION REGARDING THEIR EROSIVITY:

WARSAW LOAM (290B), JASPER SILT LOAM (440B), KISHWAUKEE SILT (623 B), ORTHENTS (802B), AND RODMAN & WARSAW COMPLEX (939C2) ARE SOIL TYPES WITHIN THE PROJECT AREA THAT HAVE MODERATE SUSCEPTIBILITY TO WATER AND WIND EROSION. ALL OTHER SOILS WITHIN THE PROJECT AREA, WHICH MAKE UP APPROXIMATELY 90% OF THE SITE, HAVE SLIGHT SUSCEPTIBILITY TO EROSION.

G. THE FOLLOWING IS A DESCRIPTION OF POTENTIALLY EROSION AREAS ASSOCIATED WITH THIS PROJECT:

THE AREAS SURROUNDING THE DRY RUN CREEK & TRIBUTARY TO DRY RUN CREEK CROSSINGS SHALL BE CLOSELY MONITORED TO PREVENT SEDIMENT FROM ENTERING THE WATERWAYS.

H. THE FOLLOWING IS A DESCRIPTION OF SOIL DISTURBING ACTIVITIES, THEIR LOCATIONS AND THEIR EROSION FACTORS (E.G. STEEPNESS OF SLOPES, LENGTH OF SLOPES, ETC.):

THE PURPOSE OF THE LAND DISTURBING ACTIVITIES ON THIS SITE ARE TO RECONSTRUCT THE EXISTING LANES ALONG WITH ADDING ADDITIONAL LANES ALONG I-90. THE RAMPS ON THE NORTH SIDE OF ROCKTON ROAD WILL BE COMPLETELY RECONSTRUCTED. DRY RUN CREEK (SN 101-0001 & 0002) BRIDGES AND WILL BE REPLACED TO ACCOMMODATE ADDITIONAL LANES. THE TRIBUTARY TO DRY RUN CREEK (SN 101-1031 & 1095) CULVERTS WILL BE REPLACED.

- I. SEE THE EROSION CONTROL PLANS AND/OR DRAINAGE PLANS FOR THIS CONTRACT FOR INFORMATION REGARDING DRAINAGE PATTERNS, APPROXIMATE SLOPES ANTICIPATED BEFORE AND AFTER MAJOR GRADING ACTIVITIES, LOCATIONS WHERE VEHICLES ENTER OR EXIT THE SITE AND CONTROLS TO PREVENT OFF SITE SEDIMENT TRACKING (TO BE ADDED AFTER CONTRACTOR IDENTIFIES LOCATIONS), AREAS OF SOIL DISTURBANCE, THE LOCATION OF MAJOR STRUCTURAL AND NON-STRUCTURAL CONTROLS IDENTIFIED IN THE PLAN, THE LOCATION OF AREAS WHERE STABILIZATION PRACTICES ARE EXPECTED TO OCCUR, SURFACE WATER (INCLUDING WETLANDS) AND LOCATIONS WHERE STORM WATER IS DISCHARGED TO SURFACE WATER INCLUDING WETLANDS.
- J. THE FOLLOWING IS A LIST OF RECEIVING WATER(S) AND THE ULTIMATE RECEIVING WATER(S), AND AREAL EXTENT OF WETLAND ACREAGE AT THE SITE, THE LOCATION OF THE RECEIVING WATERS CAN BE FOUND ON THE EROSION AND SEDIMENT CONTROL PLANS:
DRY RUN CREEK (SN 101-0001 & 0002)
- K. THE FOLLOWING POLLUTANTS OF CONCERN WILL BE ASSOCIATED WITH THIS CONSTRUCTION PROJECT: (CHECK ALL THAT APPLY)
 - SOIL SEDIMENT
 - CONCRETE
 - CONCRETE TRUCK WASTE
 - CONCRETE CURING COMPOUNDS
 - SOLID WAST DEBRIS
 - PAINTS
 - SOLVENTS
 - FERTILIZERS/PESTICIDES
 - PETROLEUM (GAS, DIESEL, OIL, KEROSENE, HYDRAULIC OIL/FLUIDS)
 - ANTIFREEZE/COOLANTS
 - WASTE WATER FROM CLEANING CONSTRUCTION EQUIPMENT
 - OTHER (SPECIFY)
 - OTHER (SPECIFY)
 - OTHER (SPECIFY)
 - OTHER (SPECIFY)

II. CONTROLS

THIS SECTION OF THE PLAN ADDRESSES THE CONTROLS THAT WILL BE IMPLEMENTED FOR EACH OF THE MAJOR CONSTRUCTION ACTIVITIES DESCRIBED IN I.C. ABOVE AND FOR ALL USE AREAS, BORROW SITES AND WASTE SITES. FOR EACH MEASURE DISCUSSED, THE CONTRACTOR WILL BE RESPONSIBLE FOR ITS IMPLEMENTATION AS INDICATED. THE CONTRACTOR SHALL PROVIDE TO THE RESIDENT ENGINEER A PLAN FOR THE IMPLEMENTATION OF THE MEASURES INDICATED. THE CONTRACTOR, AND SUBCONTRACTORS, WILL NOTIFY THE RESIDENT ENGINEER OF ANY PROPOSED CHANGES, MAINTENANCE, OR MODIFICATIONS TO KEEP CONSTRUCTION ACTIVITIES COMPLIANT WITH THE PERMIT. EACH SUCH CONTRACTOR HAS SIGNED THE REQUIRED CERTIFICATION ON FORMS WHICH WILL BE PROVIDED AT THE PRE- CONSTRUCTION CONFERENCE AND ARE A PART OF THIS PLAN.

A. EROSION AND SEDIMENT CONTROL

1. STABILIZATION PRACTICES: PROVIDED BELOW IS A DESCRIPTION OF INTERIM AND PERMANENT STABILIZATION PRACTICES, INCLUDING SITE SPECIFIC SCHEDULING OF THE IMPLEMENTATION OF THE PRACTICES. SITE PLANS WILL ENSURE THAT EXISTING VEGETATION IS PRESERVED WHERE ATTAINABLE AND DISTURBED PORTIONS OF THE SITE WILL BE STABILIZED. STABILIZATION PRACTICES MAY INCLUDE, BUT ARE NOT LIMITED TO: TEMPORARY SEEDING, PERMANENT SEEDING, MULCHING, GEOTEXTILES, SODDING, VEGETATIVE BUFFER STRIPS, PROTECTION OF TREES, PRESERVATION OF MATURE VEGETATION AND OTHER APPROPRIATE MEASURES, EXCEPT AS PROVIDED BELOW IN II(A)(1)(a) AND II(A)(3). STABILIZATION MEASURES SHALL BE INITIATED AS SOON AS PRACTICABLE IN PORTIONS OF THE SITE WHERE CONSTRUCTION ACTIVITIES HAVE TEMPORARILY OR PERMANENTLY CEASED, BUT IN NO CASE MORE THAN 14 DAYS AFTER THE CONSTRUCTION ACTIVITY IN THAT PORTION OF THE SITE HAS TEMPORARILY OR PERMANENTLY CEASED ON ALL DISTURBED PORTIONS OF THE SITE WHERE CONSTRUCTION WILL NOT OCCUR FOR A PERIOD OF 21 OR MORE CALENDAR DAYS.

a. WHERE THE INITIATION OF STABILIZATION MEASURES BY THE 14TH DAY AFTER CONSTRUCTION ACTIVITY TEMPORARILY OR PERMANENTLY CEASES IS PRECLUDED BY SNOW COVER, STABILIZATION MEASURES SHALL BE INITIATED AS SOON AS PRACTICABLE THEREAFTER

THE FOLLOWING STABILIZATION PRACTICES SHALL BE USED ON THIS PROJECT: (CHECK ALL THAT APPLY)

- PRESERVATION OF MATURE VEGETATION
- VEGETATED BUFFER STRIPS
- PROTECTION OF TREES
- TEMPORARY EROSION CONTROL SEEDING
- TEMPORARY TURF (SEEDING, CLASS 7)
- TEMPORARY MULCHING
- PERMANENT SEEDING
- EROSION CONTROL BLANKET/MULCHING
- SODDING
- GEOTEXTILES
- OTHER (SPECIFY)
- OTHER (SPECIFY)
- OTHER (SPECIFY)

DESCRIBE BELOW HOW THE STABILIZATION PRACTICES LISTED ABOVE WILL BE UTILIZED

1. PRESERVATION OF MATURE VEGETATION - EXISTING VEGETATION ALONG THE PERIMETER OF THE R.O.W. SHALL BE PRESERVED, TO THE EXTENT POSSIBLE, TO HELP MAINTAIN A PERIMETER BARRIER TO REDUCE THE POTENTIAL FOR SEDIMENT LEAVING THE SITE.

2. TEMPORARY EROSION CONTROL SEEDING - THIS ITEM WILL BE APPLIED TO ALL BARE AREAS EVERY SEVEN DAYS TO MINIMIZE THE AMOUNT OF EXPOSED SURFACE AREAS

EARTH STOCKPILES SHALL BE TEMPORARILY SEEDED IF THEY ARE TO REMAIN UNUSED FOR MORE THAN 14 DAYS.

WITHIN THE CONSTRUCTION LIMITS, AREAS WHICH MAY BE SUSCEPTIBLE TO EROSION AS DETERMINED BY THE ENGINEER SHALL REMAIN UNDISTURBED UNTIL FULL SCALE CONSTRUCTION IS UNDERWAY TO PREVENT UNNECESSARY SOIL EROSION.

BARE AND SPARSELY VEGETATED GROUND IN HIGHLY ERODIBLE AREAS AS DETERMINED BY THE ENGINEER SHALL BE TEMPORARILY SEEDED AT THE BEGINNING OF CONSTRUCTION WHERE NO CONSTRUCTION ACTIVITIES ARE EXPECTED WITHIN 7 DAYS. MULCH METHOD 2 SHALL BE APPLIED TO TEMPORARY SEEDING AREAS.

3. PERMANENT SEEDING - SEEDING, CLASS 2 WILL BE INSTALLED PER IDOT SPECIFICATIONS

4. EROSION CONTROL BLANKET/MULCHING - EROSION CONTROL BLANKETS WILL BE INSTALLED OVER FILL SLOPES AND IN HIGH VELOCITY AREAS (I.E. DITCHES) THAT HAVE BEEN BROUGHT TO FINAL GRADE AND SEEDED TO PROTECT SLOPES FROM EROSION AND ALLOW SEEDS TO GERMINATE. MULCH, METHOD 2, WILL BE APPLIED IN RELATIVELY FLAT AREAS TO PROTECT THE DISTURBED AREAS AND PREVENT FURTHER EROSION.

MULCH AS APPLIED TO TEMPORARY EROSION CONTROL SEEDING SHALL BE BY THE METHOD SPECIFIED IN THE CONTRACT AND AT THE DIRECTION OF THE ENGINEER. MULCH WILL BE PAID SEPARATELY AND SHALL CONFORM TO SECTION 251 OF THE STANDARD SPECIFICATIONS

5. GEOTEXTILES - GEOTEXTILE SHALL BE UTILIZED IN HIGH VELOCITY AREAS AND AREAS WITH STEEP SLOPES TO STABILIZE SOILS AND VEGETATION.

PERMANENT STABILIZATION - ALL AREAS DISTURBED BY CONSTRUCTION WILL BE STABILIZED WITH PERMANENT SEEDING IMMEDIATELY FOLLOWING THE FINISHED GRADING. EROSION CONTROL BLANKETS WILL BE INSTALLED OVER FILL SLOPES WHICH HAVE BEEN BROUGHT TO FINAL GRADE AND HAVE BEEN SEEDED TO PROTECT THE SLOPES FROM RILL AND GULLY EROSION AND ALLOW SEED TO GERMINATE PROPERLY. MULCH, METHOD 2, WILL BE USED ON RELATIVELY FLAT AREAS.

2. STRUCTURAL PRACTICES: PROVIDED BELOW IS A DESCRIPTION OF STRUCTURAL PRACTICES THAT WILL BE IMPLEMENTED, TO THE DEGREE ATTAINABLE, TO DIVERT FLOW FROM EXPOSED SOILS, STORE FLOWS OR OTHERWISE LIMIT RUNOFF AND THE DISCHARGE OF POLLUTANTS FROM EXPOSED AREAS OF THE SITE. SUCH PRACTICES MAY INCLUDE, BUT ARE NOT LIMITED TO: PERIMETER EROSION BARRIER, EARTH DIKES, DRAINAGE SWELLS, SEDIMENT TRAPS, DITCH CHECKS, SUBSURFACE DRAINS, PIPE SLOPE DRAINS, LEVEL SPREADERS, STORM DRAIN INLET PROTECTION, ROCK OUTLET PROTECTION, REINFORCED SOIL RETAINING SYSTEMS, GABIONS AND TEMPORARY OR PERMANENT SEDIMENT BASINS. THE INSTALLATION OF THESE DEVICES MAY BE SUBJECT TO SECTION 404 OF THE CLEAN WATER ACT.

THE FOLLOWING STRUCTURAL PRACTICES WILL BE USED FOR THIS PROJECT: (CHECK ALL THAT APPLY)

- PERIMETER EROSION BARRIER
- TEMPORARY DITCH CHECK
- STORM DRAIN INLET PROTECTION
- SEDIMENT TRAP
- TEMPORARY PIPE SLOPE DRAIN
- TEMPORARY SEDIMENT BASIN
- TEMPORARY STREAM CROSSING
- STABILIZED CONSTRUCTION EXITS
- TURF REINFORCEMENT MATS
- PERMANENT CHECK DAMS
- PERMANENT SEDIMENT BASIN
- AGGREGATE DITCH
- PAVED DITCH
- ROCK OUTLET PROTECTION
- RIPRAP
- GABIONS
- SLOPE MATTRESS
- RETAINING WALLS
- SLOPE WALLS
- CONCRETE REVETMENT MATS
- LEVEL SPREADERS
- OTHER (SPECIFY)

DESCRIBE BELOW HOW THE STRUCTURAL PRACTICES LISTED ABOVE WILL BE UTILIZED

1. PERIMETER EROSION BARRIER - SILT FENCES WILL BE PLACED ALONG THE BANKS OF DRY RUN CREEK IN AN EFFORT TO CONTAIN SILT AND RUNOFF FROM LEAVING THE SITE.

CONSTRUCT AT BEGINNING OF CONSTRUCTION, REMOVE AT END OF CONSTRUCTION.

2. STORM DRAIN INLET PROTECTION - INLET AND PIPE PROTECTION WILL BE PROVIDED FOR CULVERTS & STORM SEWER AND WILL BE CLEANED ON A REGULAR BASIS.

3. TEMPORARY DITCH CHECKS - DITCH CHECKS WILL BE PLACED IN SWALES WHERE RUNOFF VELOCITY IS HIGH. ALL STRUCTURAL PRACTICES ARE SHOWN IN DETAIL ON THE EROSION CONTROL PLANS.

TEMPORARY DITCH CHECKS SHALL BE LOCATED AT EVERY 1 FT. FALL/RISE IN DITCH GRADE.

TEMPORARY DITCH CHECKS, AGGREGATE USES GRADING NO. 3 - REMOVE AT END OF CONSTRUCTION.

STRAW BALES, HAY BALES, PERIMETER EROSION BARRIER AND SILT FENCE WILL NOT BE PERMITTED FOR TEMPORARY OR PERMANENT DITCH CHECKS. DITCH CHECKS SHALL BE COMPOSED OF AGGREGATE (IF SPECIFIED), ENVIROBERM, TRIANGULAR SILT DIKES, GEORIDGE AND ROLLED EXCELSIOR.

4. ROCK OUTLET PROTECTION - ROCK OUTLET PROTECTION SHALL BE PROVIDED AT ALL STORM SEWER POINT DISCHARGES.

5. RIPRAP - THE BRIDGE OPENING WILL BE PROTECTED WITH RR-5 RIPRAP FROM ABUTMENT TO ABUTMENT TO PREVENT EROSION AND SCOURING.

AS SOON AS REASONABLE ACCESS IS AVAILABLE TO ALL LOCATIONS WHERE WATER DRAINS AWAY FROM THE PROJECT, TEMPORARY DITCH CHECKS, INLET AND PIPE PROTECTION, AND PERIMETER EROSION BARRIER SHALL BE INSTALLED AS CALLED OUT IN THIS PLAN AND DIRECTED BY THE ENGINEER.

ALL EROSION CONTROL PRODUCTS FURNISHED SHALL BE SPECIFICALLY RECOMMENDED BY THE MANUFACTURER FOR THE USE SPECIFIED IN THE EROSION CONTROL PLAN. PRIOR TO THE APPROVAL AND USE OF THE PRODUCT, THE CONTRACTOR SHALL SUBMIT TO THE ENGINEER A NOTARIZED CERTIFICATION BY THE PRODUCER STATING THE INTENDED USE OF THE PRODUCT AND THAT THE PHYSICAL PROPERTIES REQUIRED FOR THIS APPLICATION ARE MET OR EXCEEDED. THE CONTRACTOR SHALL PROVIDE MANUFACTURER INSTALLATION PROCEDURES TO FACILITATE THE ENGINEER IN CONSTRUCTION INSPECTION.



USER NAME = .USERNAME.	DESIGNED -	REVISED -
	DRAWN - JDH	REVISED -
PLOT SCALE = 1.0000 ' / IN.	CHECKED - DW	REVISED -
PLOT DATE = 10/19/2011	DATE - 10-21-2011	REVISED -

STATE OF ILLINOIS
DEPARTMENT OF TRANSPORTATION

STORM WATER POLLUTION PREVENTION PLAN GENERAL NOTES
I-90 FROM WISCONSIN STATE LINE TO ROCKTON ROAD

SCALE: NONE SHEET NO. 1 OF 2 SHEETS STA. N/A TO STA. N/A

F.A.I. RTE. 90	SECTION (X2-1) R	COUNTY WINNEBAGO	TOTAL SHEETS 510	SHEET NO. 217
CONTRACT NO. 64C29				
ILLINOIS FED. AID PROJECT				

3. STORM WATER MANAGEMENT: PROVIDED BELOW IS A DESCRIPTION OF MEASURES THAT WILL BE INSTALLED DURING THE CONSTRUCTION PROCESS TO CONTROL POLLUTANTS IN STORM WATER DISCHARGES THAT WILL OCCUR AFTER CONSTRUCTION OPERATIONS HAVE BEEN COMPLETED. THE INSTALLATION OF THESE DEVICES MAY BE SUBJECT TO SECTION 404 OF THE CLEAN WATER ACT.

a. SUCH PRACTICES MAY INCLUDE BUT ARE NOT LIMITED TO: STORM WATER DETENTION STRUCTURES (INCLUDING WET PONDS), STORM WATER RETENTION STRUCTURES, FLOW ATTENUATION BY USE OF OPEN VEGETATED SWALES AND NATURAL DEPRESSIONS, INFILTRATION OF RUNOFF ON SITE, AND SEQUENTIAL SYSTEMS (WHICH COMBINE SEVERAL PRACTICES) THE PRACTICES SELECTED FOR IMPLEMENTATION WERE DETERMINED ON THE BASIS OF THE TECHNICAL GUIDANCE IN CHAPTER 41 (CONSTRUCTION SITE STORM WATER POLLUTION CONTROL) OF THE ILLINOIS DEPARTMENT OF TRANSPORTATION BUREAU OF DESIGN AND ENVIRONMENT MANUAL. IF PRACTICES OTHER THAN THOSE DISCUSSED IN CHAPTER 41 ARE SELECTED FOR IMPLEMENTATION OR IF PRACTICES ARE APPLIED TO SITUATIONS DIFFERENT FROM THOSE COVERED IN CHAPTER 41, THE TECHNICAL BASIS FOR SUCH DECISIONS WILL BE EXPLAINED BELOW.

b. VELOCITY DISSIPATION DEVICES WILL BE PLACED AT DISCHARGE LOCATIONS AND ALONG THE LENGTH OF ANY OUTFALL CHANNEL AS NECESSARY TO PROVIDE A NON-EROSIVE VELOCITY FLOW FROM THE STRUCTURE TO A WATER COURSE SO THAT THE NATURAL, PHYSICAL, AND BIOLOGICAL CHARACTERISTICS AND FUNCTIONS ARE MAINTAINED AND PROTECTED (E.G. MAINTENANCE OF HYDROLOGIC CONDITIONS SUCH AS THE HYDROPERIOD AND HYDRODYNAMICS PRESENT PRIOR TO THE INITIATION OF CONSTRUCTION ACTIVITIES).

DESCRIPTION OF STORM WATER MANAGEMENT CONTROLS:

THE PHASE I LOCATION DRAINAGE STUDY, PERFORMED BY STUDIES AND PLANS HAS DETERMINED THAT NO STORM WATER DETENTION IS REQUIRED FOR THIS PROJECT.

4. OTHER CONTROLS

a. VEHICLE ENTRANCES AND EXITS - STABILIZED CONSTRUCTION ENTRANCES AND EXITS MUST BE CONSTRUCTED TO PREVENT TRACKING OF SEDIMENT ONTO ROADWAYS.

THE CONTRACTOR WILL PROVIDE THE RESIDENT ENGINEER WITH A WRITTEN PLAN IDENTIFYING THE LOCATION OF STABILIZED ENTRANCES AND EXITS AND THE PROCEDURES (S)HE WILL USE TO CONSTRUCT AND MAINTAIN THEM.

b. MATERIAL DELIVERY, STORAGE, AND USE - THE FOLLOWING BMPS SHALL BE IMPLEMENTED TO HELP PREVENT DISCHARGES OF CONSTRUCTION MATERIALS DURING DELIVERY, STORAGE, AND USE:

- ALL PRODUCTS DELIVERED TO THE PROJECT SITE MUST BE PROPERLY LABELED.
- A STORAGE/CONTAINMENT FACILITY SHOULD BE CHOSEN FOR LARGER ITEMS SUCH AS DRUMS AND ITEMS SHIPPED OR STORED ON PALLETS. SUCH MATERIAL IS TO BE COVERED BY A TIN ROOF OR LARGE SHEETS OF PLASTIC TO PREVENT PRECIPITATION FROM COMING IN CONTACT WITH PRODUCT BEING STORED.
- WATER TIGHT SHIPPING CONTAINERS AND/OR SEMI TRAILERS SHALL BE USED TO STORE HAND TOOLS, SMALL PARTS AND MOST CONSTRUCTION MATERIALS THAT CAN BE CARRIED BY HAND, SUCH AS PAINT CANS, SOLVENTS, AND GREASE.
- LARGE ITEMS SUCH AS LIGHT STANDS, FRAMING MATERIALS AND LUMBER SHALL BE STORED IN THE OPEN IN A GENERAL STORAGE AREA. SUCH MATERIAL SHALL BE ELEVATED WITH WOOD BLOCKS TO MINIMIZE CONTACT WITH STORM WATER RUNOFF.
- SPILL CLEAN-UP MATERIALS, MATERIAL SAFETY DATA SHEETS, AN INVENTORY OF MATERIALS, AND EMERGENCY CONTACT NUMBERS SHALL BE MAINTAINED AND STORED IN ONE DESIGNATED AREA AND EACH CONTRACTOR IS TO INFORM HIS/HER EMPLOYEES AND THE RESIDENT ENGINEER OF THIS LOCATION.

c. STOCKPILE MANAGEMENT - BMPS SHALL BE IMPLEMENTED TO REDUCE OR ELIMINATE POLLUTION OF STORM WATER FROM STOCKPILES OF SOIL AND PAVING MATERIALS SUCH AS BUT NOT LIMITED TO PORTLAND CEMENT CONCRETE RUBBLE, ASPHALT CONCRETE, ASPHALT CONCRETE RUBBLE, AGGREGATE BASE, AGGREGATE SUB BASE, AND PRE-MIXED AGGREGATE. THE FOLLOWING BMPS MAY BE CONSIDERED:

- PERIMETER EROSION BARRIER
- TEMPORARY SEEDING
- TEMPORARY MULCH
- PLASTIC COVERS
- SOIL BINDERS
- STORM DRAIN INLET PROTECTION

THE CONTRACTOR WILL PROVIDE THE RESIDENT ENGINEER WITH A WRITTEN PLAN OF THE PROCEDURES (S)HE WILL USE ON THE PROJECT AND HOW THEY WILL BE MAINTAINED.

d. WASTE DISPOSAL. NO MATERIALS, INCLUDING BUILDING MATERIALS, SHALL BE DISCARDED INTO WATERS OF THE STATE, EXCEPT AS AUTHORIZED BY A SECTION 404 PERMIT.

e. THE PROVISIONS OF THIS PLAN SHALL ENSURE AND DEMONSTRATE COMPLIANCE WITH APPLICABLE STATE AND/OR LOCAL WASTE DISPOSAL, SANITARY SEWER OR SEPTIC SYSTEM REGULATIONS.

f. THE CONTRACTOR SHALL PROVIDE A WRITTEN AND GRAPHIC PLAN TO THE RESIDENT ENGINEER IDENTIFYING WHERE EACH OF THE ABOVE AREAS WILL BE LOCATED AND HOW THEY ARE TO BE MANAGED.

5. APPROVED STATE OR LOCAL LAWS

THE MANAGEMENT PRACTICES, CONTROLS AND PROVISIONS CONTAINED IN THIS PLAN WILL BE IN ACCORDANCE WITH IDOT SPECIFICATIONS, WHICH ARE AT LEAST AS PROTECTIVE AS THE REQUIREMENTS CONTAINED IN THE ILLINOIS ENVIRONMENTAL PROTECTION AGENCY'S ILLINOIS URBAN MANUAL, 1995. PROCEDURES AND REQUIREMENTS SPECIFIED IN APPLICABLE SEDIMENT AND EROSION SITE PLANS OR STORM WATER MANAGEMENT PLANS APPROVED BY LOCAL OFFICIALS SHALL BE DESCRIBED OR INCORPORATED BY REFERENCE IN THE SPACE PROVIDED BELOW. REQUIREMENTS SPECIFIED IN SEDIMENT AND EROSION SITE PLANS, SITE PERMITS, STORM WATER MANAGEMENT PLANS AND SITE PERMITS APPROVED BY LOCAL OFFICIALS THAT ARE APPLICABLE TO PROTECTING SURFACE WATER RESOURCES ARE, UPON SUBMITTAL OF AN NOI, TO BE AUTHORIZED TO DISCHARGE UNDER PERMIT ILR10 INCORPORATED BY REFERENCE AND ARE ENFORCEABLE UNDER THIS PERMIT EVEN IF THEY ARE NOT SPECIFICALLY INCLUDED IN THE PLAN.

DESCRIPTION OF PROCEDURES AND REQUIREMENTS SPECIFIED IN APPLICABLE SEDIMENT AND EROSION SITE PLANS OR STORM WATER MANAGEMENT PLANS APPROVED BY LOCAL OFFICIALS:

ALL MANAGEMENT PRACTICES, CONTROLS, AND OTHER PROVISIONS IN THIS PLAN ARE IN ACCORDANCE WITH "IDOT STANDARD SPECIFICATIONS FOR ROAD AND BRIDGE CONSTRUCTION AND THE ILLINOIS URBAN MANUAL".

III. MAINTENANCE

THE FOLLOWING IS A DESCRIPTION OF PROCEDURES THAT WILL BE USED TO MAINTAIN, IN GOOD AND EFFECTIVE OPERATING CONDITIONS, THE VEGETATION, EROSION AND SEDIMENT CONTROL MEASURES AND OTHER PROTECTIVE MEASURES IDENTIFIED IN THIS PLAN.

1. SEEDING - ALL ERODIBLE BARE EARTH WILL BE TEMPORARILY SEEDDED ON A WEEKLY BASIS TO MINIMIZE THE AMOUNT OF ERODIBLE SURFACE WITHIN THE CONTRACT LIMIT.
2. PERIMETER EROSION BARRIER - SEDIMENT WILL BE REMOVED IF THE INTEGRITY OF THE FENCING IS IN JEOPARDY AND ANY FENCING KNOCKED DOWN WILL BE REPAIRED IMMEDIATELY. THE COST OF THIS MAINTENANCE SHALL BE ACCORDING TO ARTICLE 109.04 OF THE STANDARD SPECIFICATIONS.
3. EROSION CONTROL BLANKET/MULCHING - ANY AREAS THAT FAIL WILL BE REPAIRED IMMEDIATELY.
4. PROTECTION OF TREES/TEMPORARY TREE PROTECTION - ANY PROTECTIVE MEASURES WHICH ARE KNOCKED DOWN WILL BE REPAIRED IMMEDIATELY.
5. DITCH CHECK - SEDIMENT WILL BE REMOVED IF THE INTEGRITY OF THE DITCH CHECK IS IN JEOPARDY. ANY DITCH CHECKS WHICH FAIL WILL BE REPAIRED OR REPLACED IMMEDIATELY.

THE RESIDENT ENGINEER WILL PROVIDE MAINTENANCE GUIDES TO THE CONTRACTOR FOR THESE PRACTICES. ALL MAINTENANCE OF EROSION CONTROL SYSTEMS WILL BE THE RESPONSIBILITY OF THE CONTRACTOR UNTIL CONSTRUCTION IS COMPLETE AND ACCEPTED BY IDOT AFTER FINAL INSPECTION. ALL LOCATIONS WHERE VEHICLES ENTER AND EXIT THE CONSTRUCTION SITE AND ALL OTHER AREAS SUBJECT TO EROSION SHOULD ALSO BE INSPECTED PERIODICALLY.

INSPECTION OF THESE AREAS SHALL BE MADE AT LEAST ONCE EVERY SEVEN DAYS AND WITHIN 24 HOURS OF THE END OF EACH 0.5 INCHES OR GREATER RAINFALL, OR EQUIVALENT SNOWFALL. THE PROJECT SHALL ADDITIONALLY BE INSPECTED BY THE CONSTRUCTION FIELD ENGINEER ON A BI-WEEKLY BASIS TO DETERMINE THAT EROSION CONTROL EFFORTS ARE IN PLACE AND EFFECTIVE AND IF OTHER EROSION CONTROL WORK IS NECESSARY.

THE TEMPORARY EROSION CONTROL SYSTEMS SHALL BE REMOVED AS DIRECTED BY THE ENGINEER AFTER USE IS NO LONGER NEEDED. THE COST OF THIS REMOVAL SHALL BE INCLUDED IN THE UNIT BID PRICE FOR THE TEMPORARY EROSION CONTROL SYSTEM.

IV. INSPECTIONS

QUALIFIED PERSONNEL SHALL INSPECT DISTURBED AREAS OF THE CONSTRUCTION SITE WHICH HAVE NOT YET BEEN FINALLY STABILIZED, STRUCTURAL CONTROL MEASURES, AND LOCATIONS WHERE VEHICLES AND EQUIPMENT ENTER AND EXIT THE SITE. SUCH INSPECTIONS SHALL BE CONDUCTED AT LEAST ONCE EVERY SEVEN (7) CALENDAR DAYS AND WITHIN 24 HOURS OF THE END OF A STORM THAT IS 0.5 INCHES OR GREATER OR EQUIVALENT SNOWFALL.

A. DISTURBED AREAS, USE AREAS (STORAGE OF MATERIALS, STOCKPILES, MACHINE MAINTENANCE, FUELING, ECT.), BORROW SITES, AND WASTE SITES SHALL BE INSPECTED FOR EVIDENCE OF, OR THE POTENTIAL FOR, POLLUTANTS ENTERING THE DRAINAGE SYSTEM. EROSION AND SEDIMENT CONTROL MEASURES IDENTIFIED IN THE PLAN SHALL BE OBSERVED TO ENSURE THAT THEY ARE OPERATING CORRECTLY. DISCHARGE LOCATIONS OR POINTS THAT ARE ACCESSIBLE, SHALL BE INSPECTED TO ASCERTAIN WHETHER EROSION CONTROL MEASURES ARE EFFECTIVE IN PREVENTING SIGNIFICANT IMPACTS TO RECEIVING WATERS. LOCATIONS WHERE VEHICLES ENTER OR EXIT THE SITE SHALL BE INSPECTED FOR EVIDENCE OF OFF SITE SEDIMENT TRACKING.

B. BASED ON THE RESULTS OF THE INSPECTION, THE DESCRIPTION OF POTENTIAL POLLUTANT SOURCES IDENTIFIED IN SECTION I ABOVE AND POLLUTION PREVENTION MEASURES IDENTIFIED IN SECTION II ABOVE SHALL BE REVISED AS APPROPRIATE AS SOON AS PRACTICAL AFTER INSPECTION. ANY CHANGES TO THIS PLAN RESULTING FROM THE REQUIRED INSPECTIONS SHALL BE IMPLEMENTED WITHIN 1/2 HOUR TO 1 WEEK BASED ON THE URGENCY OF THE SITUATION. THE RESIDENT ENGINEER WILL NOTIFY THE CONTRACTOR OF THE TIME REQUIRED TO IMPLEMENT SUCH ACTIONS THROUGH THE WEEKLY INSPECTION REPORT.

C. A REPORT SUMMARIZING THE SCOPE OF THE INSPECTION, NAME(S) AND QUALIFICATIONS OF PERSONNEL MAKING THE INSPECTION, THE DATE(S) OF THE INSPECTION, MAJOR OBSERVATIONS RELATING TO THE IMPLEMENTATION OF THIS STORM WATER POLLUTION PREVENTION PLAN, AND ACTIONS TAKEN IN ACCORDANCE WITH SECTION IV (B) SHALL BE MADE AND RETAINED AS PART OF THE PLAN FOR AT LEAST THREE (3) YEARS AFTER THE DATE OF THE INSPECTION. THE REPORT SHALL BE SIGNED IN ACCORDANCE WITH PART VI. G OF THE GENERAL PERMIT.

D. IF ANY VIOLATION OF THE PROVISIONS OF THIS PLAN IS IDENTIFIED DURING THE CONDUCT OF THE CONSTRUCTION WORK COVERED BY THIS PLAN, THE RESIDENT ENGINEER SHALL COMPLETE AND FILE AN "INCIDENCE OF NONCOMPLIANCE" (ION) REPORT FOR THE IDENTIFIED VIOLATION. THE RESIDENT ENGINEER SHALL USE FORMS PROVIDED BY THE ILLINOIS ENVIRONMENTAL PROTECTION AGENCY AND SHALL INCLUDE SPECIFIED INFORMATION ON THE CAUSE OF NON-COMPLIANCE, ACTIONS WHICH WERE TAKEN TO PREVENT ANY FURTHER CAUSES OF NON-COMPLIANCE, AND A STATEMENT DETAILING ANY ENVIRONMENTAL IMPACT WHICH MAY HAVE RESULTED FROM THE NONCOMPLIANCE. ALL REPORTS OF NONCOMPLIANCE SHALL BE SIGNED BY A RESPONSIBLE AUTHORITY IN ACCORDANCE WITH PART VI. G OF THE GENERAL PERMIT.

THE INCIDENCE OF NON-COMPLIANCE SHALL BE MAILED TO THE FOLLOWING ADDRESS:

ILLINOIS ENVIRONMENTAL PROTECTION AGENCY
DIVISION OF WATER POLLUTION CONTROL
ATTN: COMPLIANCE ASSURANCE SECTION
1021 NORTH GRAND EAST
POST OFFICE BOX 19276
SPRINGFIELD, ILLINOIS 62794-9276

V. NON-STORM WATER DISCHARGES:

EXCEPT FOR FLOWS FROM FIRE FIGHTING ACTIVITIES, SOURCES OF NON-STORM WATER THAT IS COMBINED WITH STORM WATER DISCHARGES ASSOCIATED WITH THE INDUSTRIAL ACTIVITY ADDRESSED IN THIS PLAN MUST BE DESCRIBED BELOW. APPROPRIATE POLLUTION PREVENTION MEASURES, AS DESCRIBED BELOW, WILL BE IMPLEMENTED FOR THE NON-STORM WATER COMPONENT(S) OF THE DISCHARGE.

A. SPILL PREVENTION AND CONTROL - BMPS SHALL BE IMPLEMENTED TO CONTAIN AND CLEAN-UP SPILLS AND PREVENT MATERIAL DISCHARGES TO THE STORM DRAIN SYSTEM. THE CONTRACTOR SHALL PRODUCE A WRITTEN PLAN STATING HOW HIS/HER COMPANY WILL PREVENT, REPORT, AND CLEAN UP SPILLS AND PROVIDE A COPY TO ALL OF HIS/HER EMPLOYEES AND THE RESIDENT ENGINEER. THE CONTRACTOR SHALL NOTIFY THE RESIDENT ENGINEER OF ANY SPILLS IMMEDIATELY.

B. CONCRETE RESIDUALS AND WASHOUT WASTES - THE FOLLOWING BMPS SHALL BE IMPLEMENTED TO CONTROL RESIDUAL CONCRETE, CONCRETE SEDIMENTS, AND RINSE WATER:

1. TEMPORARY CONCRETE WASHOUT FACILITIES SHALL BE CONSTRUCTED FOR RINSING OUT CONCRETE TRUCKS. SIGNS SHALL BE INSTALLED DIRECTING CONCRETE TRUCK DRIVERS WHERE DESIGNATED WASHOUT FACILITIES ARE LOCATED.
2. THE CONTRACTOR SHALL HAVE THE LOCATION OF THE TEMPORARY CONCRETE WASHOUT FACILITIES APPROVED BY THE RESIDENT ENGINEER.
3. ALL TEMPORARY CONCRETE WASHOUT FACILITIES ARE TO BE INSPECTED BY THE CONTRACTOR AFTER EACH USE AND ALL SPILLS MUST BE REPORTED TO THE RESIDENT ENGINEER AND CLEANED UP IMMEDIATELY.
4. CONCRETE WASTE SOLIDS/LIQUIDS SHALL BE DISPOSED OF PROPERLY.

C. LITTER MANAGEMENT - A PROPER NUMBER OF DUMPSTERS SHALL BE PROVIDED ON SITE TO HANDLE DEBRIS AND LITTER ASSOCIATED WITH THE PROJECT. THE CONTRACTOR IS RESPONSIBLE FOR ENSURING HIS/HER EMPLOYEES PLACE ALL LITTER INCLUDING MARKING PAINT CANS, SODA CANS, FOOD WRAPPERS, WOOD LATHE, MARKING RIBBON, CONSTRUCTION STRING, AND ALL OTHER CONSTRUCTION RELATED LITTER IN THE PROPER DUMPSTERS.

D. VEHICLES AND EQUIPMENT CLEANING - VEHICLES AND EQUIPMENT ARE TO BE CLEANED IN DESIGNATED AREAS ONLY, PREFERABLY OFFSITE.

E. VEHICLE AND EQUIPMENT FUELING - A VARIETY OF BMPS CAN BE IMPLEMENTED DURING FUELING OF VEHICLES AND EQUIPMENT TO PREVENT POLLUTION. THE CONTRACTOR SHALL INFORM THE RESIDENT ENGINEER AS TO WHICH BMPS WILL BE USED ON THE PROJECT. THE CONTRACTOR SHALL INFORM THE RESIDENT ENGINEER HOW (S)HE WILL BE INFORMING HIS/HER EMPLOYEES OF THESE BMPS (I.E. SIGNS, TRAINING, ECT.). BELOW ARE A FEW EXAMPLES OF THESE BMPS:







1. CONTAINMENT
2. SPILL PREVENTION AND CONTROL
3. USE OF DRIP PANS AND ABSORBENTS
4. AUTOMATIC SHUT-OFF NOZZLES
5. TOPPING OFF RESTRICTIONS
6. LEAK INSPECTION AND REPAIR

F. VEHICLES AND EQUIPMENT MAINTENANCE - ON SITE MAINTENANCE MUST BE PERFORMED IN ACCORDANCE WITH ALL ENVIRONMENTAL LAWS SUCH AS PROPER STORAGE AND NO DUMPING OF OLD ENGINE OIL OR OTHER FLUIDS ON SITE.

VI. FAILURE TO COMPLY:

FAILURE TO COMPLY WITH ANY PROVISIONS OF THIS STORM WATER POLLUTION PREVENTION PLAN WILL RESULT IN THE IMPLEMENTATION OF AN EROSION AND SEDIMENT CONTROL DEFICIENCY DEDUCTION AGAINST THE CONTRACTOR AND/OR PENALTIES UNDER THE NPDES PERMIT WHICH COULD BE PASSED ONTO THE CONTRACTOR.

LEGEND

-  TEMPORARY DITCH CHECK - ROLLED EXCELSIOR, SILT WEDGES/PANELS
-  EROSION CONTROL BLANKET & CLASS 2A SEED & FERTILIZER NUTRIENTS
-  MULCH METHOD 2 - CLASS 2A SEED & FERTILIZER NUTRIENTS ON FRONT SLOPE & CLASS 4 SEED ON BACKSLOPE OR BEYOND TOE OF SLOPE
-  INLET AND PIPE PROTECTION - STRAW BALES, FILTER FABRIC, AGGREGATES
-  RIPRAP
-  PERIMETER EROSION BARRIER - SILT FENCE OR OTHER AS APPROVED BY ENGINEER

McClure LOCHNER
Engineering Associates, Inc.
RWA
Engineering & Construction
OEI
Owens Engineering Inc.

USER NAME = .USERNAME.	DESIGNED -	REVISED -
PLOT SCALE = 1:8000 ' / IN.	DRAWN - JDH	REVISED -
PLOT DATE = 10/19/2011	CHECKED - DW	REVISED -
	DATE - 10-21-2011	REVISED -

**STATE OF ILLINOIS
DEPARTMENT OF TRANSPORTATION**

STORM WATER POLLUTION PREVENTION PLAN GENERAL NOTES			
I-90 FROM WISCONSIN STATE LINE TO ROCKTON ROAD			
SCALE: NONE	SHEET NO. 2 OF 2 SHEETS	STA. N/A	TO STA. N/A

F.A.I. RTE. 90	SECTION (X2-1) R	COUNTY WINNEBAGO	TOTAL SHEETS 510	SHEET NO. 218
CONTRACT NO. 64C29				
ILLINOIS FED. AID PROJECT				

MATCHLINE I-90 STA. 984+00

MATCHLINE I-90 STA. 0+00



ILLINOIS
WISCONSIN

STATELINE ROAD

TEMPORARY MOT CULVERT









WB I-90

EB I-90

1990+00

1995+00

LEGEND:

-  TEMPORARY DITCH CHECK - ROLLED EXCELSIOR, SILT WEDGES/PANELS
-  TEMPORARY DITCH CHECK - AGGREGATE
-  EROSION CONTROL BLANKET & CLASS 2A SEED & FERTILIZER NUTRIENTS
-  TURF REINFORCEMENT MAT & CLASS 4 SEED
-  MULCH METHOD 2 - CLASS 2A SEED & FERTILIZER NUTRIENTS ON FRONT SLOPE & CLASS 4 SEED ON BACKSLOPE OR BEYOND TOE OF SLOPE
-  INLET AND PIPE PROTECTION - STRAW BALES, FILTER FABRIC, AGGREGATES
-  RIPRAP
-  PERIMETER EROSION BARRIER - SILT FENCE OR OTHER AS APPROVED BY ENGINEER

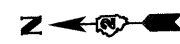

TEMPORARY MOT CULVERT

WB I-90

EB I-90

1980+00

1985+00

MATCHLINE I-90 STA. 984+00



SCALE: 1" = 50'-0"

McClure LOCHNER
Engineering Associates, Inc.
RWA
QUIGG ENGINEERING, INC.

USER NAME = USERNAME
PLOT SCALE = 50,0000' / IN.
PLOT DATE = 10/19/2011

DESIGNED -
DRAWN - JDH
CHECKED - DW
DATE - 10-21-2011

REVISED -
REVISED -
REVISED -
REVISED -

**STATE OF ILLINOIS
DEPARTMENT OF TRANSPORTATION**





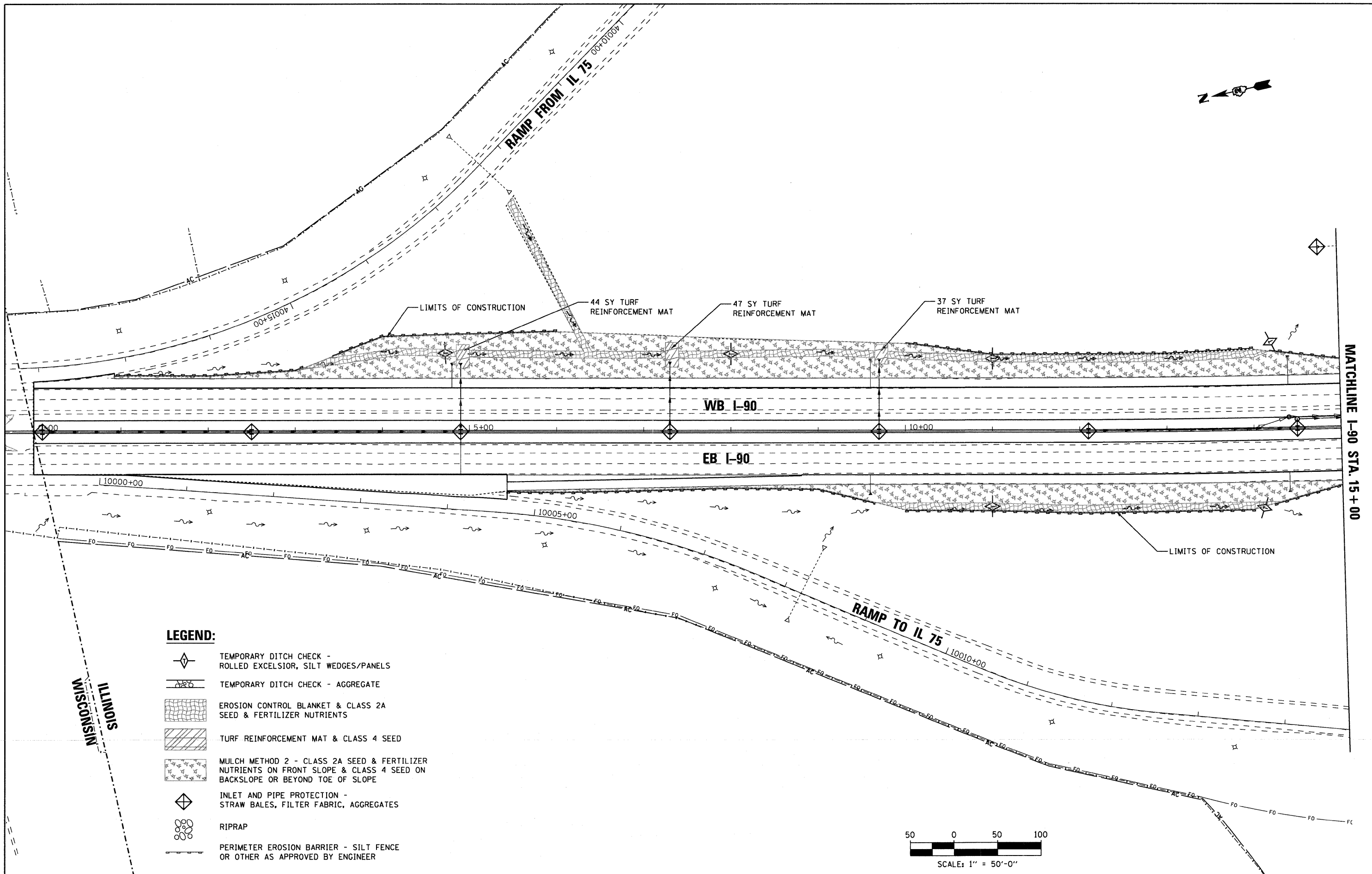



**STORM WATER POLLUTION PREVENTION PLAN
I-90 FROM WISCONSIN STATE LINE TO ROCKTON ROAD**
SCALE: 1"=50'-0" SHEET NO. 1 OF 12 SHEETS STA. 978+86 TO STA. 0+00

F.A.I. RTE.	SECTION	COUNTY	TOTAL SHEETS	SHEET NO.
90	(X2-1) R	WINNEBAGO	510	219
CONTRACT NO. 64C29				
ILLINOIS FED. AID PROJECT				



MATCHLINE I-90 STA. 15+00

LEGEND:

-  TEMPORARY DITCH CHECK - ROLLED EXCELSIOR, SILT WEDGES/PANELS
-  TEMPORARY DITCH CHECK - AGGREGATE
-  EROSION CONTROL BLANKET & CLASS 2A SEED & FERTILIZER NUTRIENTS
-  TURF REINFORCEMENT MAT & CLASS 4 SEED
-  MULCH METHOD 2 - CLASS 2A SEED & FERTILIZER NUTRIENTS ON FRONT SLOPE & CLASS 4 SEED ON BACKSLOPE OR BEYOND TOE OF SLOPE
-  INLET AND PIPE PROTECTION - STRAW BALES, FILTER FABRIC, AGGREGATES
-  RIPRAP
-  PERIMETER EROSION BARRIER - SILT FENCE OR OTHER AS APPROVED BY ENGINEER

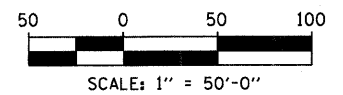

McClure LOCHNER
Engineering Inc.
RVA
Engineering Inc.
OEI
Engineering Inc.

USER NAME = .USERNAME.	DESIGNED -	REVISED -
PLOT SCALE = 50.0000' / IN.	DRAWN - JDH	REVISED -
PLOT DATE = 10/19/2011	CHECKED - DW	REVISED -
	DATE - 10-21-2011	REVISED -

STATE OF ILLINOIS
DEPARTMENT OF TRANSPORTATION

STORM WATER POLLUTION PREVENTION PLAN
I-90 FROM WISCONSIN STATE LINE TO ROCKTON ROAD

SCALE: 1"=50'-0" SHEET NO. 2 OF 12 SHEETS STA. 0+00 TO STA. 15+00

F.A.I. RTE. 90	SECTION (X2-1) R	COUNTY WINNEBAGO	TOTAL SHEETS 510	SHEET NO. 220
			CONTRACT NO. 64C29	
ILLINOIS FED. AID PROJECT				

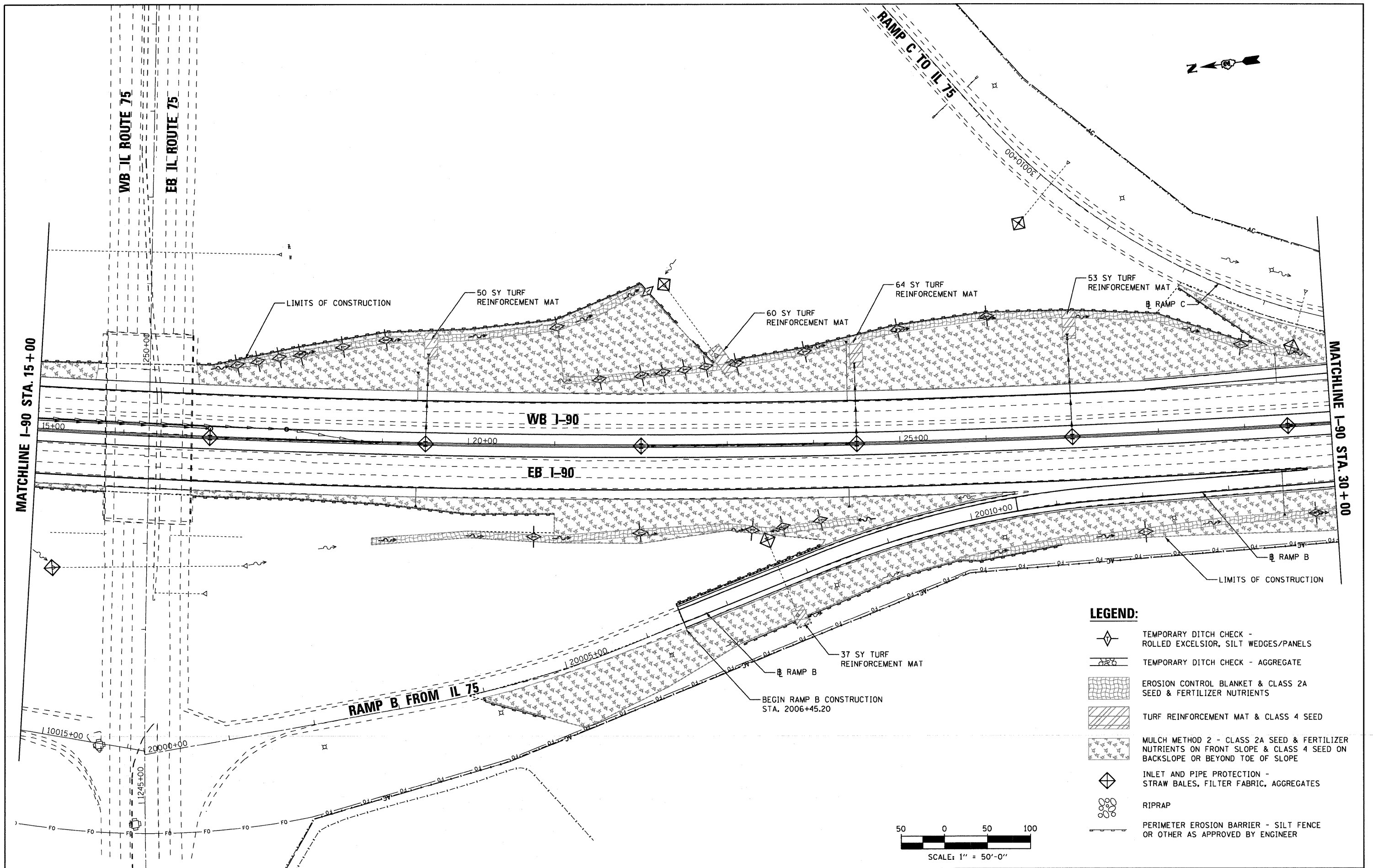

- LEGEND:**
- TEMPORARY DITCH CHECK - ROLLED EXCELSIOR, SILT WEDGES/PANELS
 - TEMPORARY DITCH CHECK - AGGREGATE
 - EROSION CONTROL BLANKET & CLASS 2A SEED & FERTILIZER NUTRIENTS
 - TURF REINFORCEMENT MAT & CLASS 4 SEED
 - MULCH METHOD 2 - CLASS 2A SEED & FERTILIZER NUTRIENTS ON FRONT SLOPE & CLASS 4 SEED ON BACKSLOPE OR BEYOND TOE OF SLOPE
 - INLET AND PIPE PROTECTION - STRAW BALES, FILTER FABRIC, AGGREGATES
 - RIPRAP
 - PERIMETER EROSION BARRIER - SILT FENCE OR OTHER AS APPROVED BY ENGINEER

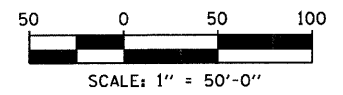

McClure LOCHNER
Engineering Associates, Inc.
RVA
Engineering & Construction, Inc.

USER NAME = .USERNAME.	DESIGNED -	REVISED -
PLOT SCALE = 50.0000' / IN.	DRAWN - JDH	REVISED -
PLOT DATE = 10/19/2011	CHECKED - DW	REVISED -
	DATE - 10-21-2011	REVISED -

**STATE OF ILLINOIS
DEPARTMENT OF TRANSPORTATION**







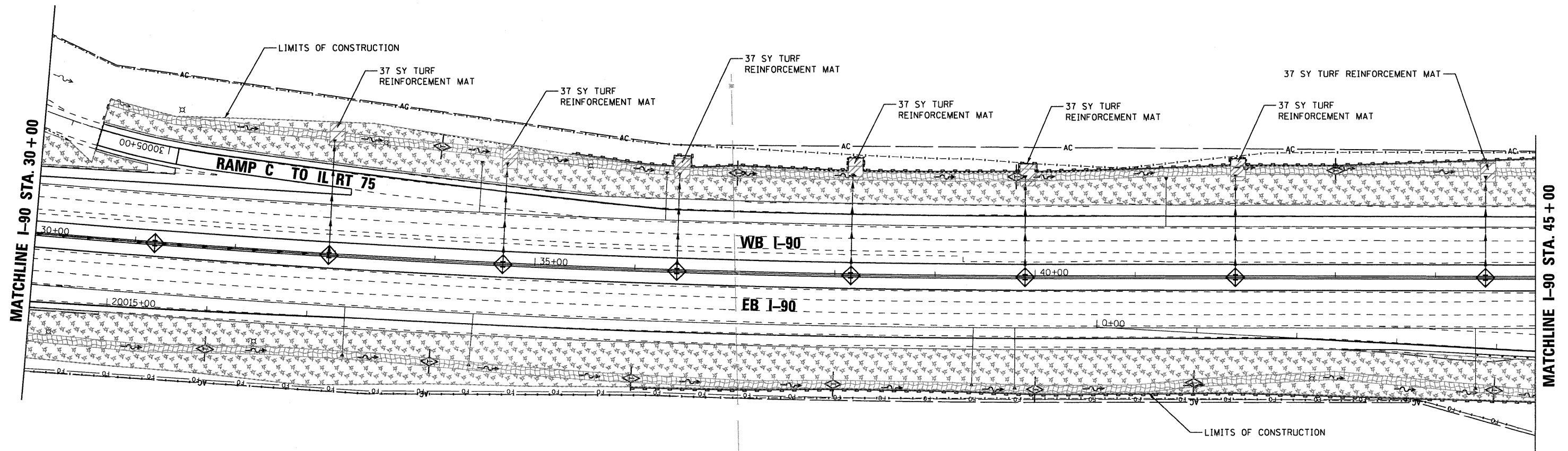

STORM WATER POLLUTION PREVENTION PLAN
I-90 FROM WISCONSIN STATE LINE TO ROCKTON ROAD

SCALE: 1"=50'-0" SHEET NO. 3 OF 12 SHEETS STA. 15+00 TO STA. 30+00

F.A.I. RTE.	SECTION	COUNTY	TOTAL SHEETS	SHEET NO.
90	(X2-1) R	WINNEBAGO	510	221
CONTRACT NO. 64C29				
ILLINOIS FED. AID PROJECT				



LEGEND:

-  TEMPORARY DITCH CHECK - ROLLED EXCELSIOR, SILT WEDGES/PANELS
-  TEMPORARY DITCH CHECK - AGGREGATE
-  EROSION CONTROL BLANKET & CLASS 2A SEED & FERTILIZER NUTRIENTS
-  TURF REINFORCEMENT MAT & CLASS 4 SEED
-  MULCH METHOD 2 - CLASS 2A SEED & FERTILIZER NUTRIENTS ON FRONT SLOPE & CLASS 4 SEED ON BACKSLOPE OR BEYOND TOE OF SLOPE
-  INLET AND PIPE PROTECTION - STRAW BALES, FILTER FABRIC, AGGREGATES
-  RIPRAP
-  PERIMETER EROSION BARRIER - SILT FENCE OR OTHER AS APPROVED BY ENGINEER

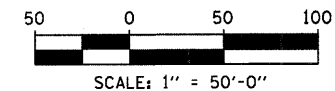







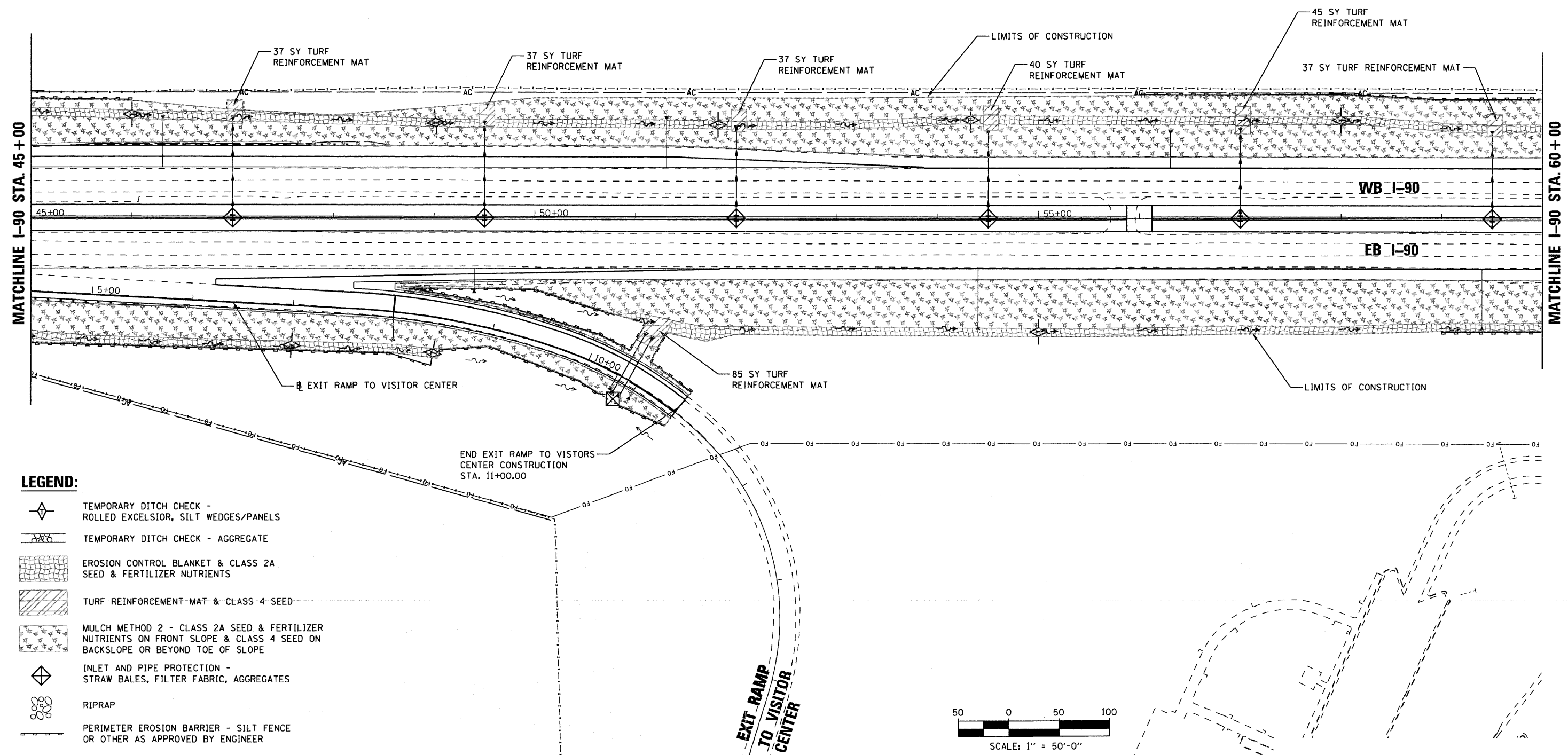

USER NAME = .USERNAME.	DESIGNED -	REVISED -
PLOT SCALE = 50.0000' / IN.	DRAWN - JDH	REVISED -
PLOT DATE = 10/19/2011	CHECKED - DW	REVISED -
	DATE - 10-21-2011	REVISED -

**STATE OF ILLINOIS
DEPARTMENT OF TRANSPORTATION**

STORM WATER POLLUTION PREVENTION PLAN			
I-90 FROM WISCONSIN STATE LINE TO ROCKTON ROAD			
SCALE: 1"=50'-0"	SHEET NO. 4 OF 12 SHEETS	STA. 30+00	TO STA. 45+00

F.A.I. RTE. 90	SECTION (X2-1) R	COUNTY WINNEBAGO	TOTAL SHEETS 510	SHEET NO. 222
CONTRACT NO. 64C29			ILLINOIS FED. AID PROJECT	



-  TEMPORARY DITCH CHECK - ROLLED EXCELSIOR, SILT WEDGES/PANELS
-  TEMPORARY DITCH CHECK - AGGREGATE
-  EROSION CONTROL BLANKET & CLASS 2A SEED & FERTILIZER NUTRIENTS
-  TURF REINFORCEMENT MAT & CLASS 4 SEED
-  MULCH METHOD 2 - CLASS 2A SEED & FERTILIZER NUTRIENTS ON FRONT SLOPE & CLASS 4 SEED ON BACKSLOPE OR BEYOND TOE OF SLOPE
-  INLET AND PIPE PROTECTION - STRAW BALES, FILTER FABRIC, AGGREGATES
-  RIPRAP
-  PERIMETER EROSION BARRIER - SILT FENCE OR OTHER AS APPROVED BY ENGINEER

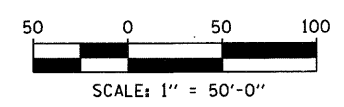

McClure LOCHNER
Engineering Associates, Inc.
RWA
Regina Weaver & Associates, Inc.

USER NAME = .USERNAME.	DESIGNED -	REVISED -
PLLOT SCALE = 50.0000' / IN.	DRAWN - JDH	REVISED -
PLLOT DATE = 10/19/2011	CHECKED - DW	REVISED -
	DATE - 10-21-2011	REVISED -

**STATE OF ILLINOIS
DEPARTMENT OF TRANSPORTATION**

**STORM WATER POLLUTION PREVENTION PLAN
I-90 FROM WISCONSIN STATE LINE TO ROCKTON ROAD**

SCALE: 1"=50'-0" SHEET NO. 5 OF 12 SHEETS STA. 45+00 TO STA. 60+00

F.A.I. RTE.	SECTION	COUNTY	TOTAL SHEETS	SHEET NO.
90	(X2-1) R	WINNEBAGO	510	223
CONTRACT NO. 64C29				
ILLINOIS FED. AID PROJECT				

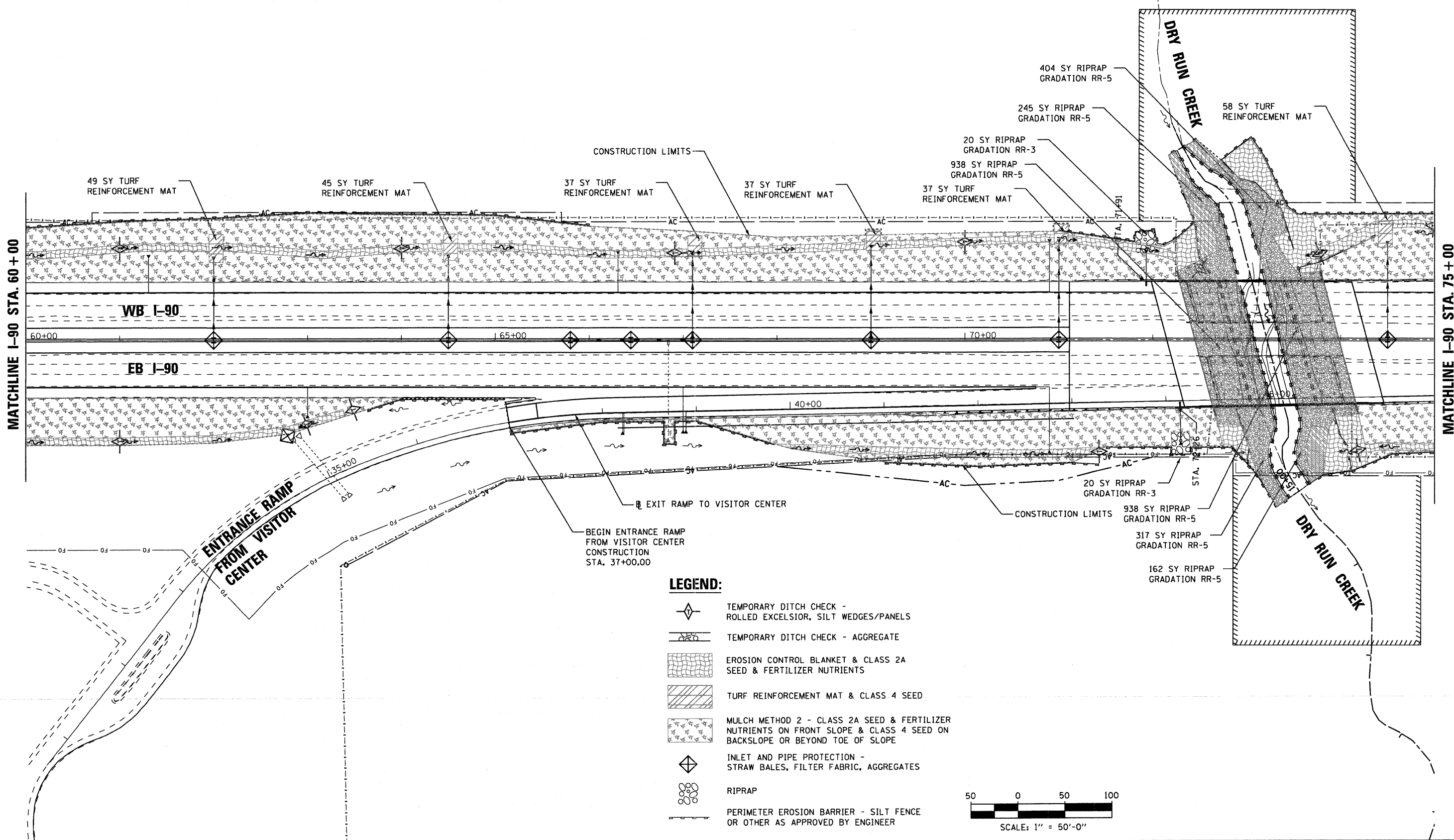
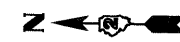

- LEGEND:**
- TEMPORARY DITCH CHECK - ROLLED EXCELSIOR, SILT WEDGES/PANELS
 - TEMPORARY DITCH CHECK - AGGREGATE
 - EROSION CONTROL BLANKET & CLASS 2A SEED & FERTILIZER NUTRIENTS
 - TURF REINFORCEMENT MAT & CLASS 4 SEED
 - MULCH METHOD 2 - CLASS 2A SEED & FERTILIZER NUTRIENTS ON FRONT SLOPE & CLASS 4 SEED ON BACKSLOPE OR BEYOND TOE OF SLOPE
 - INLET AND PIPE PROTECTION - STRAW BALES, FILTER FABRIC, AGGREGATES
 - RIPRAP
 - PERIMETER EROSION BARRIER - SILT FENCE OR OTHER AS APPROVED BY ENGINEER

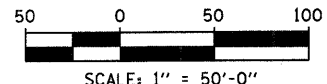

McClure LOCHNER
Engineering & Consulting, Inc.

RVA
Engineering & Consulting, Inc.

OEI
GUSGO ENGINEERING INC.

USER NAME = .USERNAME.	DESIGNED -	REVISED -
PLOT SCALE = 50.0000' / IN.	DRAWN - JDH	REVISED -
PLOT DATE = 10/19/2011	CHECKED - DW	REVISED -
	DATE - 10-21-2011	REVISED -

**STATE OF ILLINOIS
DEPARTMENT OF TRANSPORTATION**







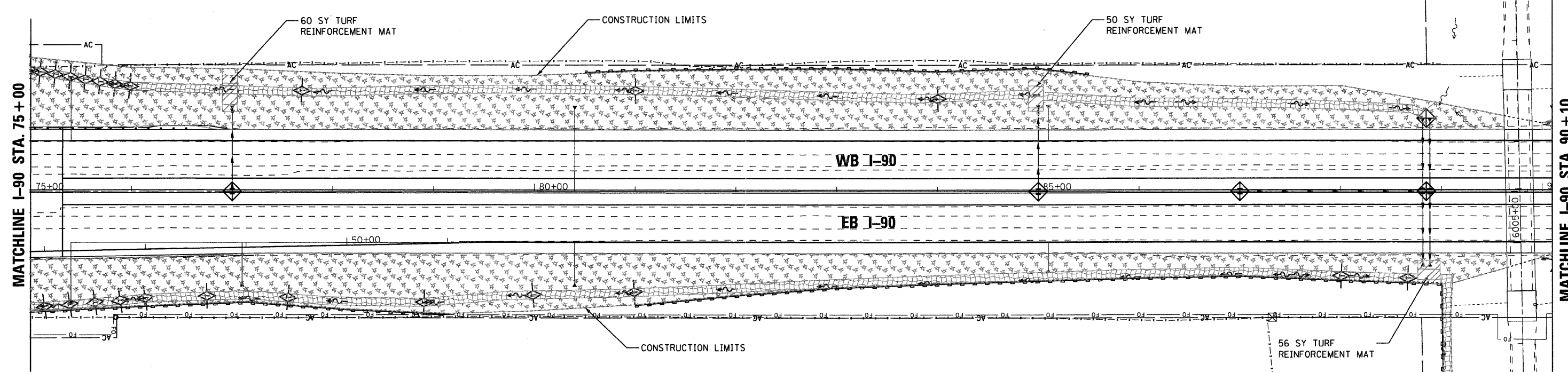
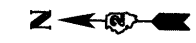

STORM WATER POLLUTION PREVENTION PLAN
I-90 FROM WISCONSIN STATE LINE TO ROCKTON ROAD

SCALE: 1"=50'-0" SHEET NO. 6 OF 12 SHEETS STA. 60+00 TO STA. 75+00

F.A.I. RTE.	SECTION	COUNTY	TOTAL SHEETS	SHEET NO.
90	(X2-1) R	WINNEBAGO	510	224
CONTRACT NO. 64C29			ILLINOIS FED. AID PROJECT	



LEGEND:

-  TEMPORARY DITCH CHECK - ROLLED EXCELSIOR, SILT WEDGES/PANELS
-  TEMPORARY DITCH CHECK - AGGREGATE
-  EROSION CONTROL BLANKET & CLASS 2A SEED & FERTILIZER NUTRIENTS
-  TURF REINFORCEMENT MAT & CLASS 4 SEED
-  MULCH METHOD 2 - CLASS 2A SEED & FERTILIZER NUTRIENTS ON FRONT SLOPE & CLASS 4 SEED ON BACKSLOPE OR BEYOND TOE OF SLOPE
-  INLET AND PIPE PROTECTION - STRAW BALES, FILTER FABRIC, AGGREGATES
-  RIPRAP
-  PERIMETER EROSION BARRIER - SILT FENCE OR OTHER AS APPROVED BY ENGINEER

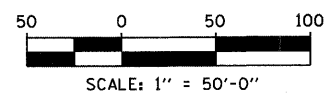

USER NAME = .USERNAME.	DESIGNED -	REVISED -
PLOT SCALE = 50.0000' / 1" IN.	DRAWN - JDH	REVISED -
PLOT DATE = 10/19/2011	CHECKED - DW	REVISED -
	DATE - 10-21-2011	REVISED -

**STATE OF ILLINOIS
DEPARTMENT OF TRANSPORTATION**







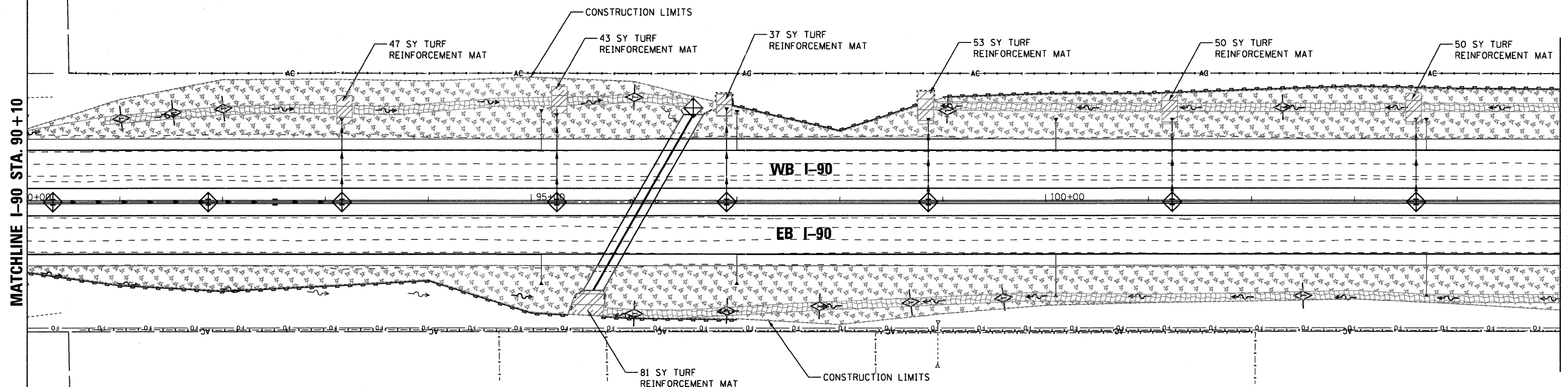

**STORM WATER POLLUTION PREVENTION PLAN
I-90 FROM WISCONSIN STATE LINE TO ROCKTON ROAD**

SCALE: 1"=50'-0" SHEET NO. 7 OF 12 SHEETS STA. 75+00 TO STA. 90+10

F-A1 RTE. 90	SECTION (X2-1) R	COUNTY WINNEBAGO	TOTAL SHEETS 510	SHEET NO. 225
CONTRACT NO. 64C29			ILLINOIS FED. AID PROJECT	



LEGEND:

-  TEMPORARY DITCH CHECK - ROLLED EXCELSIOR, SILT WEDGES/PANELS
-  TEMPORARY DITCH CHECK - AGGREGATE
-  EROSION CONTROL BLANKET & CLASS 2A SEED & FERTILIZER NUTRIENTS
-  TURF REINFORCEMENT MAT & CLASS 4 SEED
-  MULCH METHOD 2 - CLASS 2A SEED & FERTILIZER NUTRIENTS ON FRONT SLOPE & CLASS 4 SEED ON BACKSLOPE OR BEYOND TOE OF SLOPE
-  INLET AND PIPE PROTECTION - STRAW BALES, FILTER FABRIC, AGGREGATES
-  RIPRAP
-  PERIMETER EROSION BARRIER - SILT FENCE OR OTHER AS APPROVED BY ENGINEER

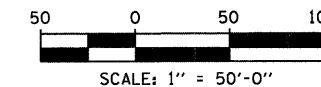

USER NAME = ..USERNAME..	DESIGNED -	REVISED -
PLOT SCALE = 50,000' / 1"	DRAWN - JDH	REVISED -
PLOT DATE = 10/19/2011	CHECKED - DW	REVISED -
	DATE - 10-21-2011	REVISED -

**STATE OF ILLINOIS
DEPARTMENT OF TRANSPORTATION**







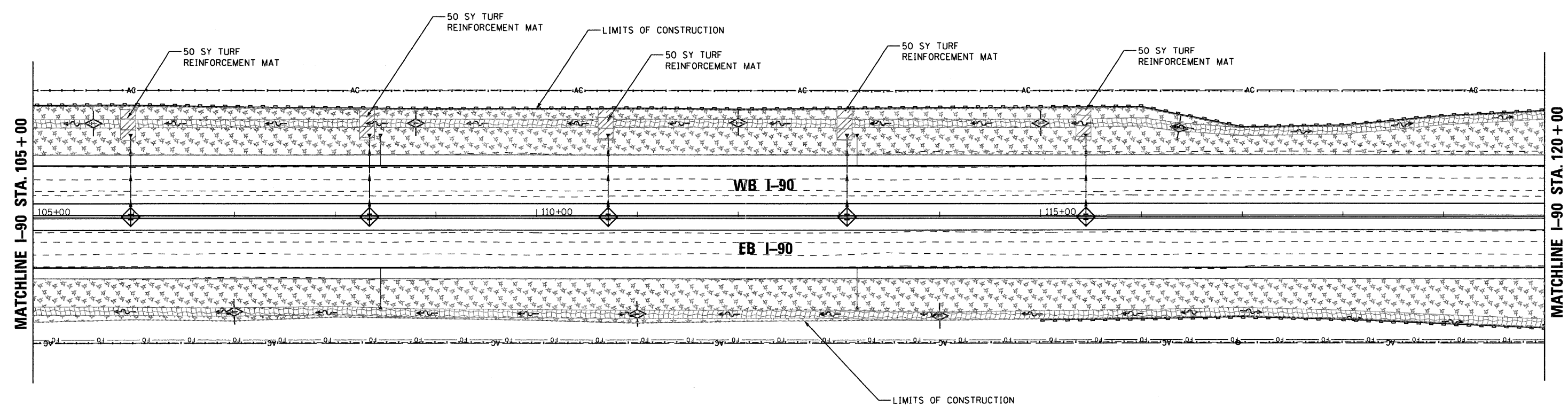

**STORM WATER POLLUTION PREVENTION PLAN
I-90 FROM WISCONSIN STATE LINE TO ROCKTON ROAD**

SCALE: 1"=50'-0" SHEET NO. 8 OF 12 SHEETS STA. 90+10 TO STA. 105+00

F.A.I. RTE. 90	SECTION (X2-1) R	COUNTY WINNEBAGO	TOTAL SHEETS 510	SHEET NO. 226
			CONTRACT NO. 64C29	
ILLINOIS FED. AID PROJECT				



LEGEND:

-  TEMPORARY DITCH CHECK - ROLLED EXCELSIOR, SILT WEDGES/PANELS
-  TEMPORARY DITCH CHECK - AGGREGATE
-  EROSION CONTROL BLANKET & CLASS 2A SEED & FERTILIZER NUTRIENTS
-  TURF REINFORCEMENT MAT & CLASS 4 SEED
-  MULCH METHOD 2 - CLASS 2A SEED & FERTILIZER NUTRIENTS ON FRONT SLOPE & CLASS 4 SEED ON BACKSLOPE OR BEYOND TOE OF SLOPE
-  INLET AND PIPE PROTECTION - STRAW BALES, FILTER FABRIC, AGGREGATES
-  RIPRAP
-  PERIMETER EROSION BARRIER - SILT FENCE OR OTHER AS APPROVED BY ENGINEER

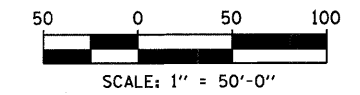

USER NAME = .USERNAME.	DESIGNED -	REVISED -
PLOT SCALE = 50,000 / IN.	DRAWN - JDH	REVISED -
PLOT DATE = 10/19/2011	CHECKED - DW	REVISED -
	DATE - 10-21-2011	REVISED -

**STATE OF ILLINOIS
DEPARTMENT OF TRANSPORTATION**

STORM WATER POLLUTION PREVENTION PLAN			
I-90 FROM WISCONSIN STATE LINE TO ROCKTON ROAD			
SCALE: 1"=50'-0"	SHEET NO. 9 OF 12 SHEETS	STA. 105+10	TO STA. 120+00

F-A-I RTE. 90	SECTION (X2-1) R	COUNTY WINNEBAGO	TOTAL SHEETS 510	SHEET NO. 227
CONTRACT NO. 64C29			ILLINOIS FED. AID PROJECT	

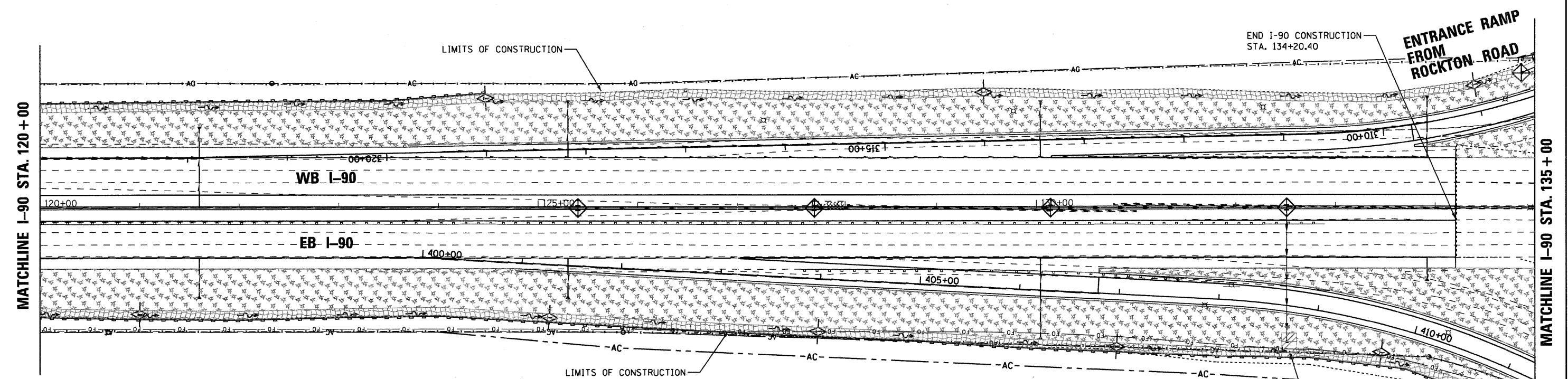



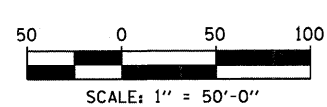



- LEGEND:**
- TEMPORARY DITCH CHECK - ROLLED EXCELSIOR, SILT WEDGES/PANELS
 - TEMPORARY DITCH CHECK - AGGREGATE
 - EROSION CONTROL BLANKET & CLASS 2A SEED & FERTILIZER NUTRIENTS
 - TURF REINFORCEMENT MAT & CLASS 4 SEED
 - MULCH METHOD 2 - CLASS 2A SEED & FERTILIZER NUTRIENTS ON FRONT SLOPE & CLASS 4 SEED ON BACKSLOPE OR BEYOND TOE OF SLOPE
 - INLET AND PIPE PROTECTION - STRAW BALES, FILTER FABRIC, AGGREGATES
 - RIPRAP
 - PERIMETER EROSION BARRIER - SILT FENCE OR OTHER AS APPROVED BY ENGINEER



	USER NAME = .USERNAME.	DESIGNED -	REVISED -	STATE OF ILLINOIS DEPARTMENT OF TRANSPORTATION	STORM WATER POLLUTION PREVENTION PLAN I-90 FROM WISCONSIN STATE LINE TO ROCKTON ROAD		F.A.I. RTE.	SECTION	COUNTY	TOTAL SHEETS	SHEET NO.
	PLOT SCALE = 50,000' / IN.	DRAWN - JDH	REVISED -		90	(X2-1) R	WINNEBAGO	510	228	CONTRACT NO. 64C29	
	PLOT DATE = 10/19/2011	CHECKED - DW	REVISED -	SCALE: 1"=50'-0"		SHEET NO. 10 OF 12 SHEETS	STA. 120+00	TO STA. 135+00	ILLINOIS FED. AID PROJECT		
		DATE - 10-21-2011	REVISED -								

LEGEND:

-  TEMPORARY DITCH CHECK - ROLLED EXCELSIOR, SILT WEDGES/PANELS
-  TEMPORARY DITCH CHECK - AGGREGATE
-  EROSION CONTROL BLANKET & CLASS 2A SEED & FERTILIZER NUTRIENTS
-  MULCH METHOD 2 - CLASS 2A SEED & FERTILIZER NUTRIENTS ON FRONT SLOPE & CLASS 4 SEED ON BACKSLOPE OR BEYOND TOE OF SLOPE
-  INLET AND PIPE PROTECTION - STRAW BALES, FILTER FABRIC, AGGREGATES
-  RIPRAP
-  PERIMETER EROSION BARRIER - SILT FENCE OR OTHER AS APPROVED BY ENGINEER

MATCHLINE I-90 STA. 135 + 00

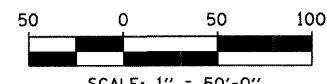
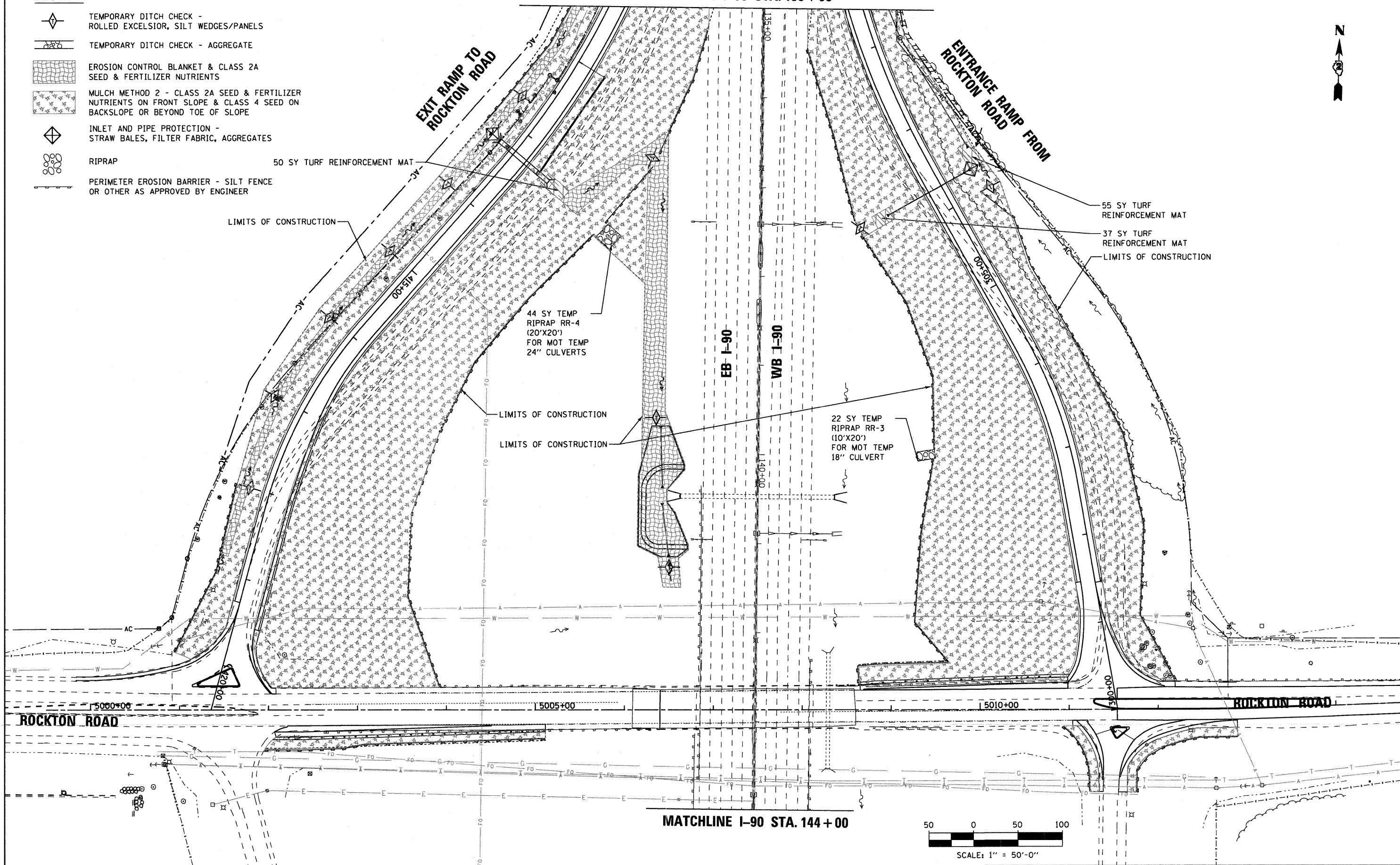

MATCHLINE I-90 STA. 144 + 00

McClure LOCHNER
Engineering Associates, Inc.
RWA
Rain Water & Associates, Inc.

USER NAME = .USERNAME.
DESIGNED -
DRAWN - JDH
CHECKED - DW
DATE - 10-21-2011

REVISI...
REVISI...
REVISI...
REVISI...

STATE OF ILLINOIS
DEPARTMENT OF TRANSPORTATION

STORM WATER POLLUTION PREVENTION PLAN
I-90 FROM WISCONSIN STATE LINE TO ROCKTON ROAD
SCALE: 1"=50'-0" SHEET NO. 11 OF 12 SHEETS STA. 135+00 TO STA. 144+00







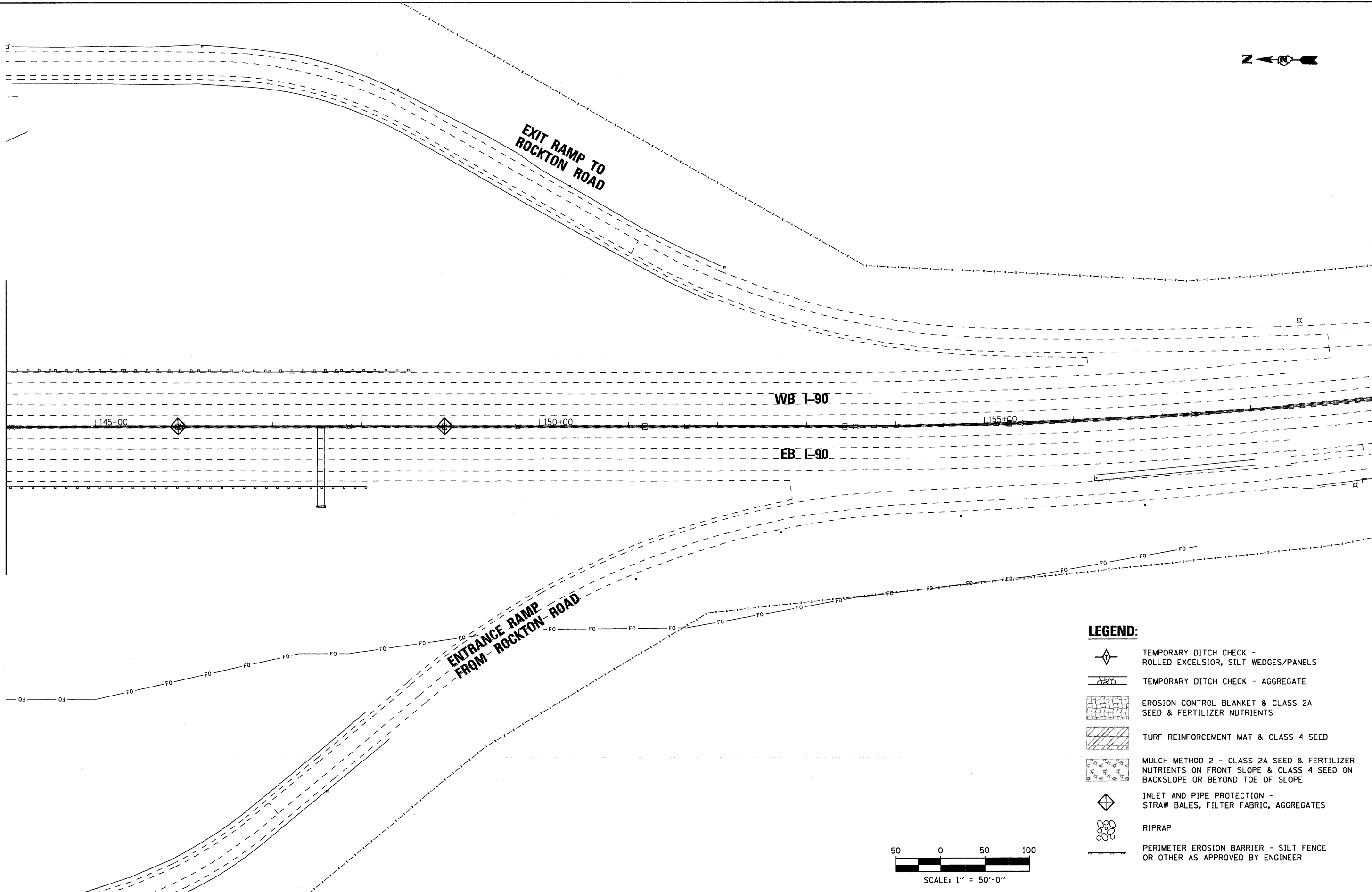

F.A.I. RTE. 90	SECTION (K2-1) R	COUNTY WINNEBAGO	TOTAL SHEETS 510	SHEET NO. 229
CONTRACT NO. 64C29			ILLINOIS FED. AID PROJECT	



MATCHLINE I-90 STA. 144+00



LEGEND:

-  TEMPORARY DITCH CHECK - ROLLED EXCELSIOR, SILT WEDGES/PANELS
-  TEMPORARY DITCH CHECK - AGGREGATE
-  EROSION CONTROL BLANKET & CLASS 2A SEED & FERTILIZER NUTRIENTS
-  TURF REINFORCEMENT MAT & CLASS 4 SEED
-  MULCH METHOD 2 - CLASS 2A SEED & FERTILIZER NUTRIENTS ON FRONT SLOPE & CLASS 4 SEED ON BACKSLOPE OR BEYOND TOE OF SLOPE
-  INLET AND PIPE PROTECTION - STRAW BALES, FILTER FABRIC, AGGREGATES
-  RIPRAP
-  PERIMETER EROSION BARRIER - SILT FENCE OR OTHER AS APPROVED BY ENGINEER

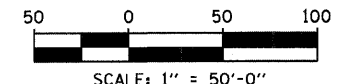

SCALE: 1" = 50'-0"

McClure LOCHNER
Engineering Associates, Inc.
200 W. LOCHNER, CHICAGO, ILLINOIS

RVA
Riprap & Aggregate, Inc.

QEG
QUIGG ENGINEERING INC.

USER NAME = .USERNAME.	DESIGNED -	REVISED -
PLOT SCALE = 50.0000' / IN.	DRAWN - JDH	REVISED -
PLOT DATE = 10/19/2011	CHECKED - DW	REVISED -
	DATE - 10-21-2011	REVISED -

**STATE OF ILLINOIS
DEPARTMENT OF TRANSPORTATION**

**STORM WATER POLLUTION PREVENTION PLAN
I-90 FROM WISCONSIN STATE LINE TO ROCKTON ROAD**

SCALE: 1"=50'-0" SHEET NO. 12 OF 12 SHEETS STA. 144+00 TO STA. 159+39

F.A.I. RTE.	SECTION	COUNTY	TOTAL SHEETS	SHEET NO.
90	(X2-1) R	WINNEBAGO	510	230
CONTRACT NO. 64C29				
ILLINOIS FED. AID PROJECT				



I 90 PARTNERS LLC

DRAINAGE STRUCTURE SCHEDULE

NO.	LOCATION		TYPE	RIM ELEV	INVERT ELEVATION			
	STATION	OFFSET			(IN)	(IN)	(IN)	(OUT)
1	0+10	0.0	DR STR T4 W/2 T20F&G	802.23 LT				798.29
2	2+50	0.0	DR STR T4 W/2 T20F&G	802.13 RT				796.96
3	4+90	0.0	*DR STR T5 W/2 T22F&G	800.28	797.34			796.00
4	4+90	80.7 LT	PRC FL END S EQ RS 24	-				795.83
5	7+30	0.0	DR STR T4 SPL W/2 T20F&G	799.37				795.31
6	7+30	81.3 LT	PRC FL END S EQ RS 18	-				795.11
7	9+70	0.0	DR STR T4 SPL W/2 T20F&G	798.46				794.58
8	9+70	80.2 LT	PRC FL END S EQ RS 18	-				794.39
9	12+10	0.0	DR STR T4 W/2 T20F&G	797.54				793.10
10	14+50	0.0	DR STR T4 W/2 T20F&G	796.63	792.11			791.86
11	14+50	10.5 LT	MAN TA 4 DIA T1F CL	796.91	791.84			791.84

*-ORIENT BOTH FRAME AND GRATES FOR [3] WITH FLOW DIRECTION. STRUCTURE IS NOT LOCATED IN AS SUMP.

LEGEND

- DRAINAGE STRUCTURES
- STORM SEWERS

UNDERDRAIN CONNECTION NOTE:

CONTRACTOR SHALL CONNECT THE PROPOSED PIPE UNDERDRAIN (OF DIAMETER SPECIFIED) TO THE PROPOSED INLET AT AN ELEVATION OF 2.50' BELOW THE RIM ELEVATION OF THE INLET BEING CONNECTED TO. THIS WORK SHALL BE IN ACCORDANCE WITH SECTION 601 OF THE STATE STANDARDS AND STATE STANDARD 601001-04 AND SHALL BE INCLUDED IN THE PAY ITEM PIPE UNDERDRAINS OF THE DIAMETER SPECIFIED OR THE KIND OF MATERIAL AND DIAMETER SPECIFIED.

DANIEL D & DEBORAH L JOHNSON

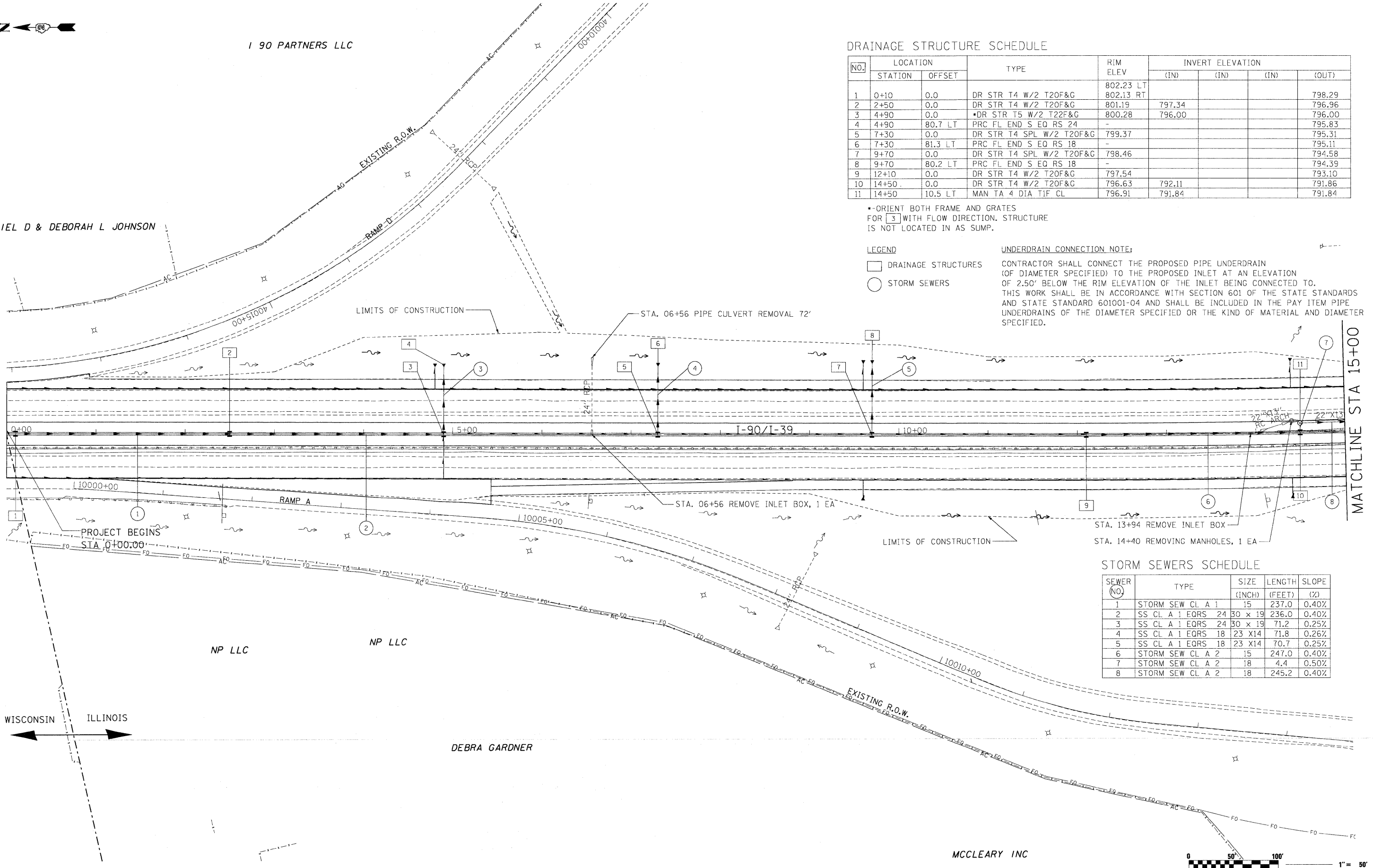

STORM SEWERS SCHEDULE

SEWER NO.	TYPE	SIZE (INCH)	LENGTH (FEET)	SLOPE (%)
1	STORM SEW CL A 1	15	237.0	0.40%
2	SS CL A 1 EQRS 24	30 x 19	236.0	0.40%
3	SS CL A 1 EQRS 24	30 x 19	71.2	0.25%
4	SS CL A 1 EQRS 18	23 X14	71.8	0.26%
5	SS CL A 1 EQRS 18	23 X14	70.7	0.25%
6	STORM SEW CL A 2	15	247.0	0.40%
7	STORM SEW CL A 2	18	4.4	0.50%
8	STORM SEW CL A 2	18	245.2	0.40%

NP LLC

NP LLC

DEBRA GARDNER

WISCONSIN ILLINOIS

MCCLERY INC

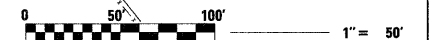

USER NAME = .USERNAME.	DESIGNED - DA	REVISED -
PLOT SCALE = 50.0000' / IN.	DRAWN - DA	REVISED -
PLOT DATE = 10/19/2011	CHECKED - AM	REVISED -
	DATE - 10/14/2011	REVISED -

STATE OF ILLINOIS
DEPARTMENT OF TRANSPORTATION

I-90 DRAINAGE PLANS

SCALE: SHEET NO. OF SHEETS STA. 0+00 TO STA. 15+00

F.A.I. RTE.	SECTION	COUNTY	TOTAL SHEETS	SHEET NO.
90	(X2-1)R	WINNEBAGO	510	231
CONTRACT NO. 64C29			ILLINOIS FED. AID PROJECT	

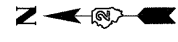

DRAINAGE STRUCTURE SCHEDULE

NO.	LOCATION		TYPE	RIM ELEV	INVERT ELEVATION			
	STATION	OFFSET			(IN)	(IN)	(IN)	(OUT)
12	17+00	10.5 LT	MAN TA 4 DIA TIF CL	795.96	790.85			790.85
13	17+00	0.0	DR STR T4 W/2 T20F&G	795.68	790.83			790.33
14	19+50	0.0	DR STR T4 SPL W/2 T20F&G	794.68	789.32			789.32
15	19+50	98.0 LT	PRC FLAR END SEC 24	-				788.17
16	22+00	0.0	DR STR T4 W/2 T20F&G	792.94				788.77
17	24+50	0.0	DR STR T4 W/2 T20F&G	790.65	786.48			785.93
18	24+50	95.7 LT	PRC FLAR END SEC 18	-				784.93
19	27+00	0.0	DR STR T4 W/2 T20F&G	788.35				783.05
20	27+00	110.1 LT	PRC FLAR END SEC 18	-				782.70
21	29+50	0.0	DR STR T4 W/2 T20F&G	786.13				781.69

LEGEND

- DRAINAGE STRUCTURES
- STORM SEWERS

UNDERDRAIN CONNECTION NOTE:

CONTRACTOR SHALL CONNECT THE PROPOSED PIPE UNDERDRAIN (OF DIAMETER SPECIFIED) TO THE PROPOSED INLET AT AN ELEVATION OF 2.50' BELOW THE RIM ELEVATION OF THE INLET BEING CONNECTED TO. THIS WORK SHALL BE IN ACCORDANCE WITH SECTION 601 OF THE STATE STANDARDS AND STATE STANDARD 601001-04 AND SHALL BE INCLUDED IN THE PAY ITEM PIPE UNDERDRAINS OF THE DIAMETER SPECIFIED OR THE KIND OF MATERIAL AND DIAMETER SPECIFIED.

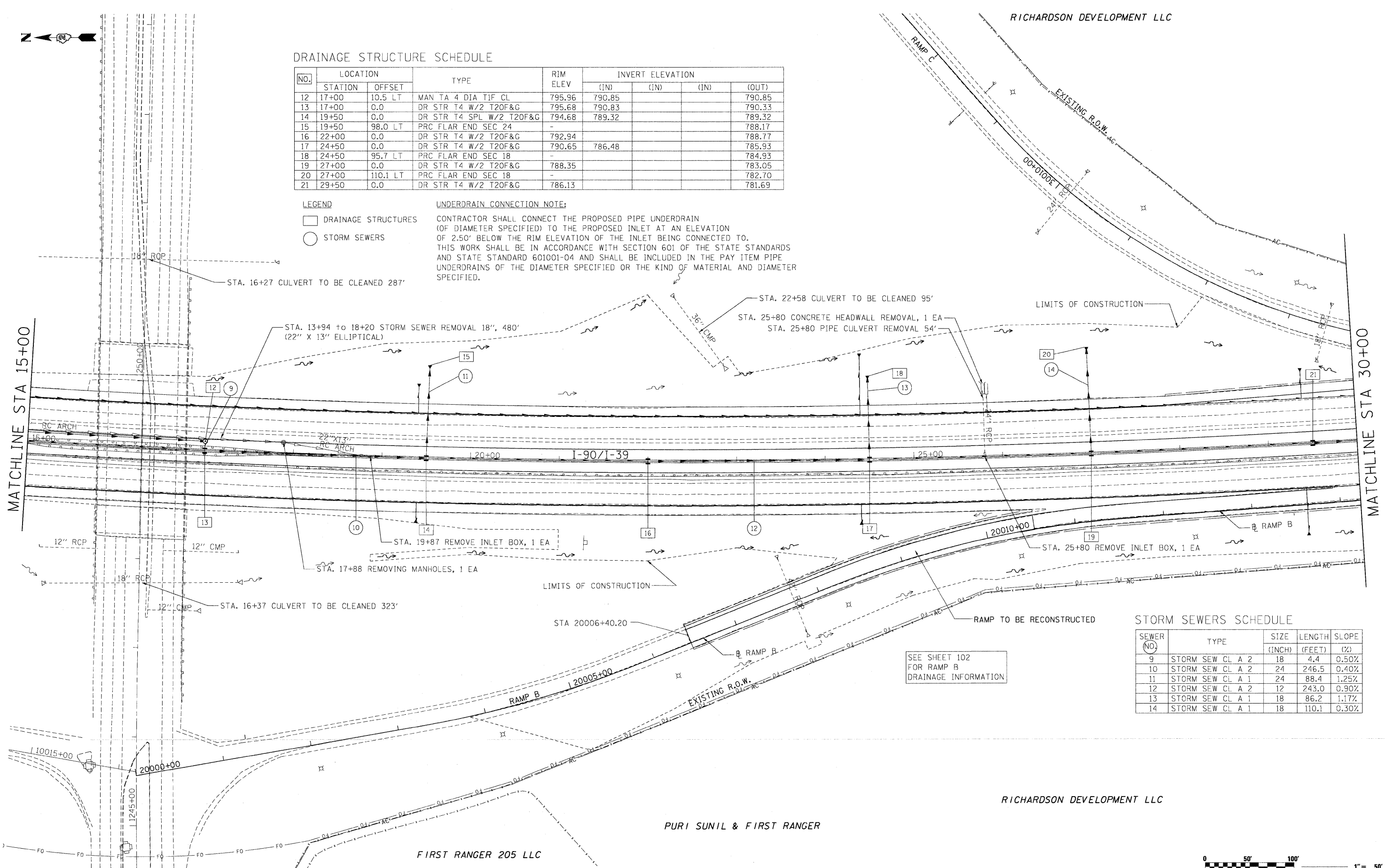

STORM SEWERS SCHEDULE

SEWER NO.	TYPE	SIZE (INCH)	LENGTH (FEET)	SLOPE (%)
9	STORM SEW CL A 2	18	4.4	0.50%
10	STORM SEW CL A 2	24	246.5	0.40%
11	STORM SEW CL A 1	24	88.4	1.25%
12	STORM SEW CL A 2	12	243.0	0.90%
13	STORM SEW CL A 1	18	86.2	1.17%
14	STORM SEW CL A 1	18	110.1	0.30%

SEE SHEET 102 FOR RAMP B DRAINAGE INFORMATION

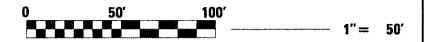



DRAINAGE STRUCTURE SCHEDULE

NO.	LOCATION		TYPE	RIM ELEV	INVERT ELEVATION			
	STATION	OFFSET			(IN)	(IN)	(IN)	(OUT)
22	31+20	0.0	DR STR T4 W/2 T20F&G	785.11	781.04			780.77
23	32+94	0.0	DR STR T4 SPL W/2 T20F&G	784.52	780.10			779.58
24	32+94	110.0 LT	PRC FL END S EQ RS 18	-				778.94
25	34+68	0.0	DR STR T4 SPL W/2 T20F&G	784.00				778.64
26	34+68	99.8 LT	PRC FL END S EQ RS 18	-				778.38
27	36+42	0.0	DR STR T4 W/2 T20F&G	783.48				778.10
28	36+42	90.6 LT	PRC FLAR END SEC 18	-				777.87
29	38+16	0.0	DR STR T4 W/2 T20F&G	782.95				777.58
30	38+16	90.5 LT	PRC FLAR END SEC 18	-				777.35
31	39+90	0.0	DR STR T4 W/2 T20F&G	782.43				777.06
32	39+90	90.7 LT	PRC FLAR END SEC 18	-				776.83
33	42+00	0.0	DR STR T4 W/2 T20F&G	781.80				777.10
34	42+00	96.7 LT	PRC FLAR END SEC 18	-				776.26
35	44+50	0.0	DR STR T4 W/2 T20F&G	781.05				776.35
36	44+50	96.7 LT	PRC FLAR END SEC 18	-				775.51

STORM SEWERS SCHEDULE

SEWER NO.	TYPE	SIZE (INCH)	LENGTH (FEET)	SLOPE (%)
15	STORM SEW CL A 1	15	163.0	0.40%
16	STORM SEW CL A 1	18	166.5	0.40%
17	SS CL A 1 EQRS 18	23 X14	100.5	0.60%
18	SS CL A 1 EQRS 18	23 X14	90.3	0.27%
19	STORM SEW CL A 1	18	81.0	0.26%
20	STORM SEW CL A 1	18	80.9	0.26%
21	STORM SEW CL A 1	18	81.1	0.26%
22	STORM SEW CL A 2	18	87.1	0.90%
23	STORM SEW CL A 2	18	87.1	0.90%

RICHARDSON DEVELOPMENT LLC

SEE SHEET 100 FOR RAMP C DRAINAGE INFORMATION

DYN RESIDENTIAL HOLDINGS LLC

LEGEND

- DRAINAGE STRUCTURES
- STORM SEWERS

UNDERDRAIN CONNECTION NOTE:

CONTRACTOR SHALL CONNECT THE PROPOSED PIPE UNDERDRAIN (OF DIAMETER SPECIFIED) TO THE PROPOSED INLET AT AN ELEVATION OF 2.50' BELOW THE RIM ELEVATION OF THE INLET BEING CONNECTED TO. THIS WORK SHALL BE IN ACCORDANCE WITH SECTION 601 OF THE STATE STANDARDS AND STATE STANDARD 601001-04 AND SHALL BE INCLUDED IN THE PAY ITEM PIPE UNDERDRAINS OF THE DIAMETER SPECIFIED OR THE KIND OF MATERIAL AND DIAMETER SPECIFIED.

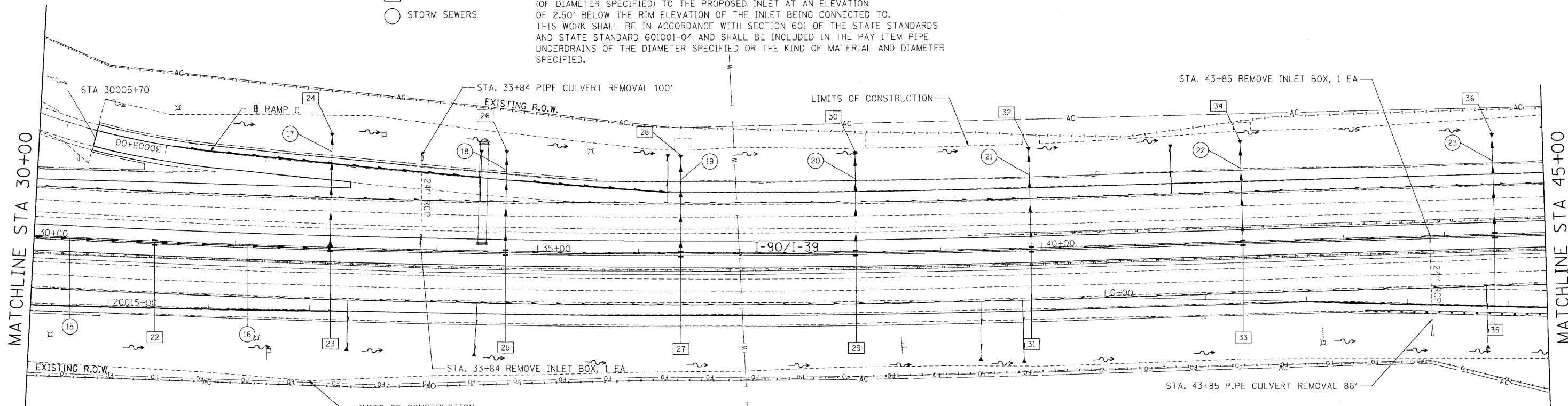

SEE SHEET 102 FOR RAMP B DRAINAGE INFORMATION

SEE SHEET 106 FOR VISITOR CENTER RAMP DRAINAGE INFORMATION

GERONIMO DEVELOPMENT LLC

RICHARDSON DEVELOPMENT LLC

RICHARDSON DEVELOPMENT LLC

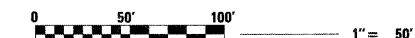

USER NAME = .USERNAME.	DESIGNED - DA	REVISED -
PLOT SCALE = 50.0000' / IN.	DRAWN - DA	REVISED -
PLOT DATE = 10/19/2011	CHECKED - AM	REVISED -
	DATE - 10/14/2011	REVISED -

STATE OF ILLINOIS
DEPARTMENT OF TRANSPORTATION

I-90 DRAINAGE PLANS

SCALE: SHEET NO. OF SHEETS STA. 30+00 TO STA. 45+00

F.A.I. RTE. 90	SECTION (X2-1)R	COUNTY WINNEBAGO	TOTAL SHEETS 510	SHEET NO. 233
			CONTRACT NO. 64C29	
ILLINOIS FED. AID PROJECT				

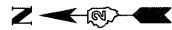

DYN RESIDENTIAL HOLDINGS LLC

DRAINAGE STRUCTURE SCHEDULE

NO.	LOCATION		TYPE	RIM ELEV	INVERT ELEVATION			
	STATION	OFFSET			(IN)	(IN)	(IN)	(OUT)
37	47+00	0.0	DR STR T4 W/2 T20F&G	780.30				775.61
38	47+00	88.3 LT	PRC FLAR END SEC 18	-				774.77
39	49+50	0.0	DR STR T4 W/2 T20F&G	779.55				774.84
40	49+50	85.6 LT	PRC FLAR END SEC 18	-				774.02
41	52+00	0.0	DR STR T4 W/2 T20F&G	778.80				774.07
42	52+00	83.4 LT	PRC FLAR END SEC 18	-				773.27
43	54+50	0.0	DR STR T4 W/2 T20F&G	778.05				773.35
44	54+50	87.0 LT	PRC FLAR END SEC 18	-				772.52
45	57+00	0.0	DR STR T4 W/2 T20F&G	777.30				772.69
46	57+00	95.6 LT	PRC FLAR END SEC 18	-				771.77
47	59+50	0.0	DR STR T4 W/2 T20F&G	776.55				771.79
48	59+50	81.3 LT	PRC FLAR END SEC 18	-				771.02

STORM SEWERS SCHEDULE

SEWER NO.	TYPE	SIZE (INCH)	LENGTH (FEET)	SLOPE (%)
24	STORM SEW CL A 2	18	78.7	1.00%
25	STORM SEW CL A 2	18	76.0	1.00%
26	STORM SEW CL A 2	18	73.9	1.00%
27	STORM SEW CL A 2	18	77.4	1.00%
28	STORM SEW CL A 2	18	77.4	1.00%
29	STORM SEW CL A 2	18	71.7	1.00%

DEE DEE PLANKEY

LEGEND

- DRAINAGE STRUCTURES
- STORM SEWERS

UNDERDRAIN CONNECTION NOTE:

CONTRACTOR SHALL CONNECT THE PROPOSED PIPE UNDERDRAIN (OF DIAMETER SPECIFIED) TO THE PROPOSED INLET AT AN ELEVATION OF 2.50' BELOW THE RIM ELEVATION OF THE INLET BEING CONNECTED TO. THIS WORK SHALL BE IN ACCORDANCE WITH SECTION 601 OF THE STATE STANDARDS AND STATE STANDARD 601001-04 AND SHALL BE INCLUDED IN THE PAY ITEM PIPE UNDERDRAINS OF THE DIAMETER SPECIFIED OR THE KIND OF MATERIAL AND DIAMETER SPECIFIED.

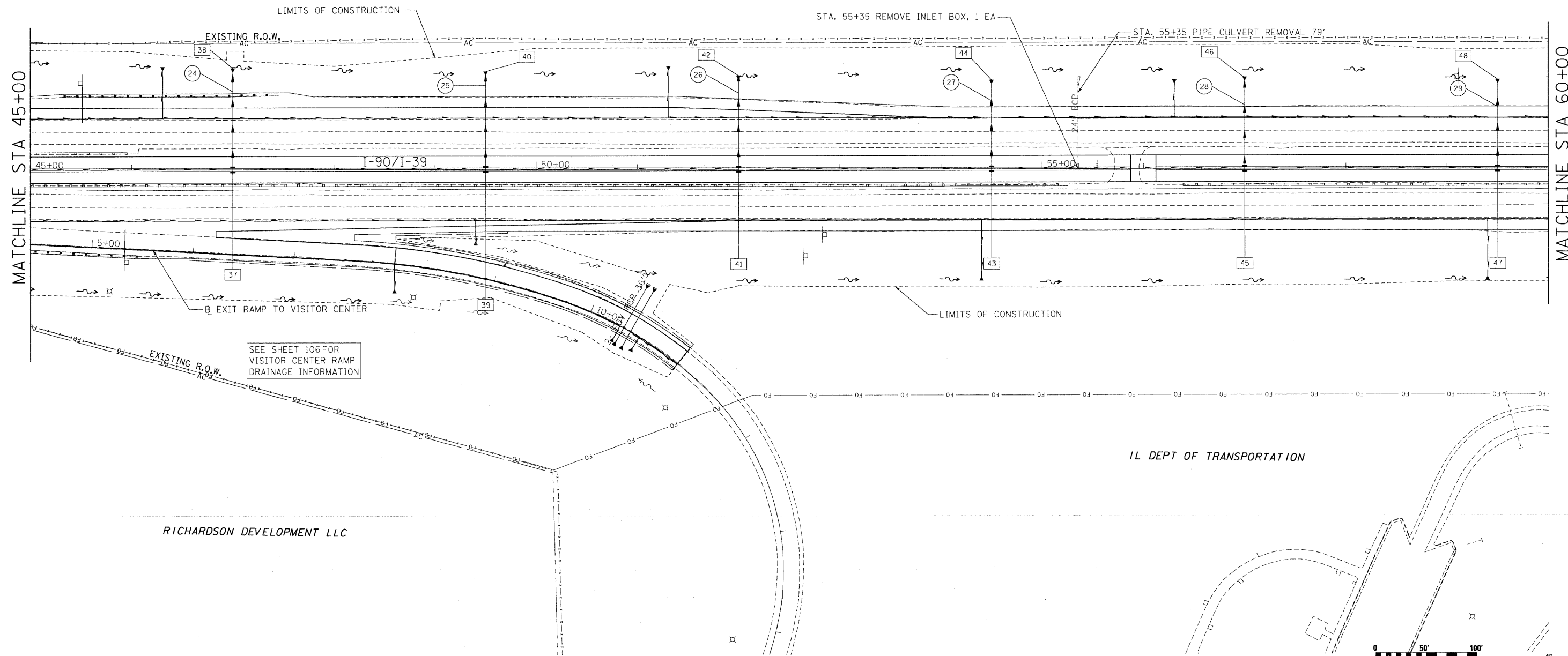

RICHARDSON DEVELOPMENT LLC

IL DEPT OF TRANSPORTATION

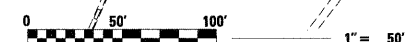

	USER NAME = .USERNAME_	DESIGNED - DA	REVISED -	STATE OF ILLINOIS DEPARTMENT OF TRANSPORTATION	I-90 DRAINAGE PLANS	F.A.I. RTE. 90	SECTION (X2-1)R	COUNTY WINNEBAGO	TOTAL SHEETS 510	SHEET NO. 234
	PLOT SCALE = 50.0000' / IN.	CHECKED - AM	REVISOR -			DATE - 10/14/2011	SCALE:	SHEET NO. OF SHEETS	STA. 45+00 TO STA. 60+00	CONTRACT NO. 64C29
ILLINOIS FED. AID PROJECT										

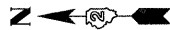

DRAINAGE STRUCTURE SCHEDULE

NO.	LOCATION		TYPE	RIM ELEV	INVERT ELEVATION		
	STATION	OFFSET			(IN)	(IN)	(OUT)
49	62+00	0.0	DR STR T4 W/2 T20F&G	775.80			771.10
50	62+00	87.0 LT	PRC FLAR END SEC 18	-			770.27
51	64+50	0.0	DR STR T4 W/2 T20F&G	775.05			770.35
52	64+50	87.0 LT	PRC FLAR END SEC 18	-			769.52
53	65+80	0.0	DR STR T4 W/2 T20F&G	774.66			770.22
54	66+44.25	0.0	DR STR T5 W/2 T22F&G	774.55	770.04		769.77
55	67+10	0.0	DR STR T4 W/2 T20F&G	774.67	769.59		769.59
56	67+10	83.3 LT	PRC FLAR END SEC 18	-			768.77
57	69+00	0.0	DR STR T4 W/2 T20F&G	775.60			769.51
58	69+00	90.8 LT	PRC FLAR END SEC 18	-			768.20
59	71+00	0.0	DR STR T4 W/2 T20F&G	776.60			769.03
60	71+00	98.8 LT	PRC FLAR END SEC 18	-			767.60
61	74+50	0.0	DR STR T4 W/2 T20F&G	778.35			766.45
62	74+50	109.1 LT	PRC FLAR END SEC 18	-			764.87

LEGEND

- DRAINAGE STRUCTURES
- STORM SEWERS

UNDERDRAIN CONNECTION NOTE:

CONTRACTOR SHALL CONNECT THE PROPOSED PIPE UNDERDRAIN (OF DIAMETER SPECIFIED) TO THE PROPOSED INLET AT AN ELEVATION OF 2.50' BELOW THE RIM ELEVATION OF THE INLET BEING CONNECTED TO. THIS WORK SHALL BE IN ACCORDANCE WITH SECTION 601 OF THE STATE STANDARDS AND STATE STANDARD 601001-04 AND SHALL BE INCLUDED IN THE PAY ITEM PIPE UNDERDRAINS OF THE DIAMETER SPECIFIED OR THE KIND OF MATERIAL AND DIAMETER SPECIFIED.

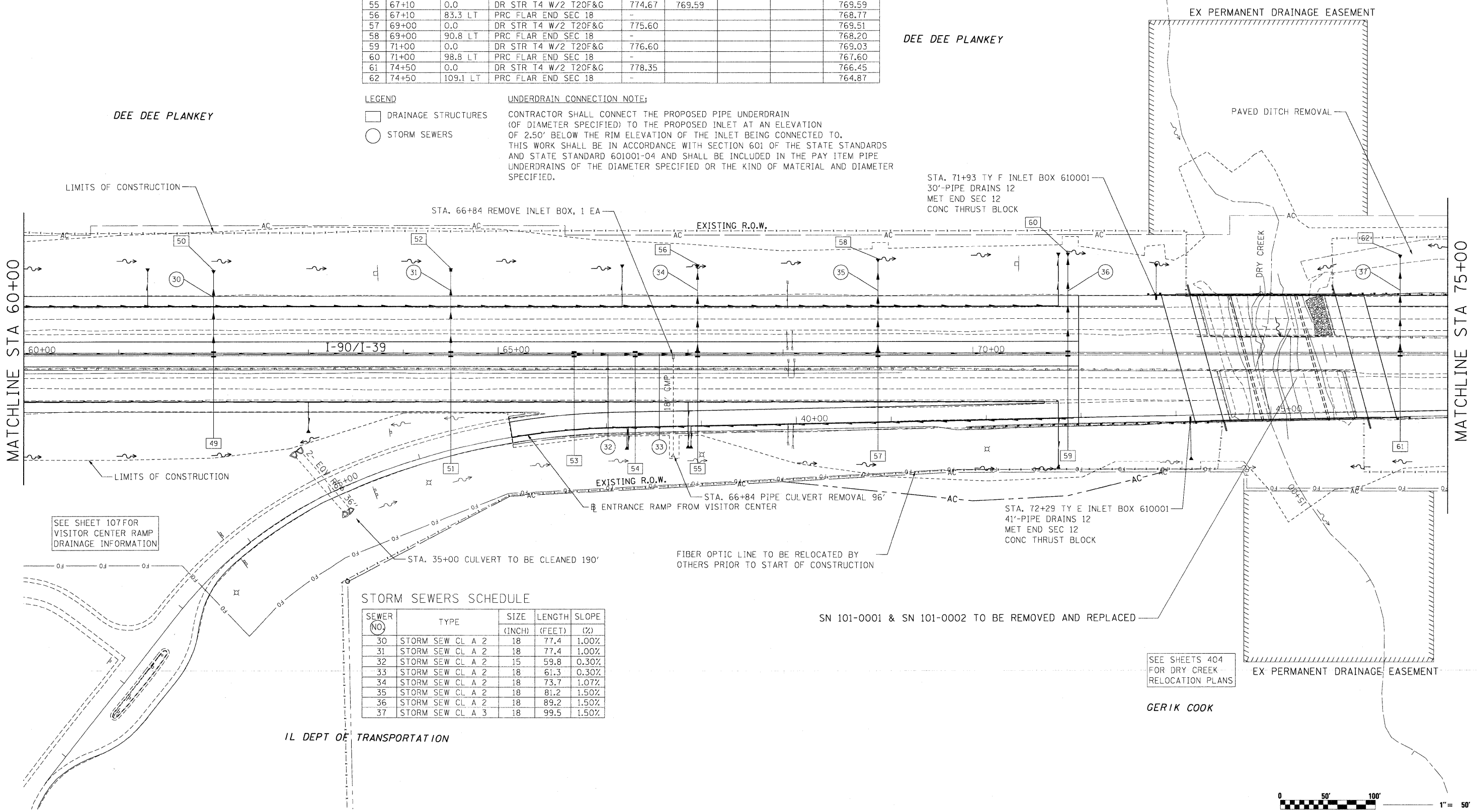

STORM SEWERS SCHEDULE

SEWER NO.	TYPE	SIZE (INCH)	LENGTH (FEET)	SLOPE (%)
31	STORM SEW CL A 2	18	77.4	1.00%
32	STORM SEW CL A 2	15	59.8	0.30%
33	STORM SEW CL A 2	18	61.3	0.30%
34	STORM SEW CL A 2	18	73.7	1.07%
35	STORM SEW CL A 2	18	81.2	1.50%
36	STORM SEW CL A 2	18	89.2	1.50%
37	STORM SEW CL A 3	18	99.5	1.50%

IL DEPT OF TRANSPORTATION

SEE SHEET 107 FOR VISITOR CENTER RAMP DRAINAGE INFORMATION

SEE SHEETS 404 FOR DRY CREEK RELOCATION PLANS

GERIK COOK

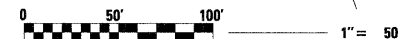

USER NAME = USERNAME	DESIGNED - DA	REVISED -
PLLOT SCALE = 50.0000' / IN.	DRAWN - DA	REVISED -
PLLOT DATE = 10/19/2011	CHECKED - AM	REVISED -
	DATE - 10/14/2011	REVISED -

STATE OF ILLINOIS
DEPARTMENT OF TRANSPORTATION

I-90 DRAINAGE PLANS

SCALE: SHEET NO. OF SHEETS STA. 60+00 TO STA. 75+00

F.A.I. RTE.	SECTION	COUNTY	TOTAL SHEETS	SHEET NO.
90	(X2-1)R	WINNEBAGO	510	235
CONTRACT NO. 64C29			ILLINOIS FED. AID PROJECT	



DRAINAGE STRUCTURE SCHEDULE

NO.	LOCATION		TYPE	RIM ELEV	INVERT ELEVATION			
	STATION	OFFSET			(IN)	(IN)	(IN)	(OUT)
63	77+00	0.0	DR STR T4 W/2 T20F&G	779.60				773.68
64	77+00	89.9 LT	PRC FLAR END SEC 18	-				772.38
65	85+00	0.0	DR STR T4 W/2 T20F&G	779.91				775.20
66	85+00	84.9 LT	PRC FLAR END SEC 18	-				774.71
67	87+00	0.0	DR STR T4 W/2 T20F&G	779.27				775.85
68	88+81.50	0.0	DR STR T4 SPL W/2 T20F&G	778.68	775.00			775.00
68-A	88+88.50	0.0	DR STR T4 SPL W/2 T20F&G	778.68				775.00
99	88+81.50	88.1 RT	PRC FL END S EQ RS 18	-				774.60
100	88+88.50	88.1 RT	PRC FL END S EQ RS 18	-				774.60
101	88+81.5	76.5 LT	PRC FL END S EQ RS 18	-				775.21
102	88+88.50	76.5 LT	PRC FL END S EQ RS 18	-				775.21

STORM SEWERS SCHEDULE

SEWER NO.	TYPE	SIZE (INCH)	LENGTH (FEET)	SLOPE (%)
39	STORM SEW CL A 2	18	75.4	0.60%
40	SS CL A 1 EQRS 18	23 X14	178.0	0.48%
59	SS CL A 1 EQRS 18	23 X14	71.6	0.57%
60	SS CL A 1 EQRS 18	23 X14	71.6	0.57%
61	SS CL A 1 EQRS 18	23 X14	67.0	0.57%
62	SS CL A 1 EQRS 18	23 X14	67.0	0.57%
63	SS CL A 1 EQRS 18	23 X14	3.0	0.00%

LEGEND

- DRAINAGE STRUCTURES
- STORM SEWERS

UNDERDRAIN CONNECTION NOTE:

CONTRACTOR SHALL CONNECT THE PROPOSED PIPE UNDERDRAIN (OF DIAMETER SPECIFIED) TO THE PROPOSED INLET AT AN ELEVATION OF 2.50' BELOW THE RIM ELEVATION OF THE INLET BEING CONNECTED TO. THIS WORK SHALL BE IN ACCORDANCE WITH SECTION 601 OF THE STATE STANDARDS AND STATE STANDARD 601001-04 AND SHALL BE INCLUDED IN THE PAY ITEM PIPE UNDERDRAINS OF THE DIAMETER SPECIFIED OR THE KIND OF MATERIAL AND DIAMETER SPECIFIED.

DEE DEE PLANKEY

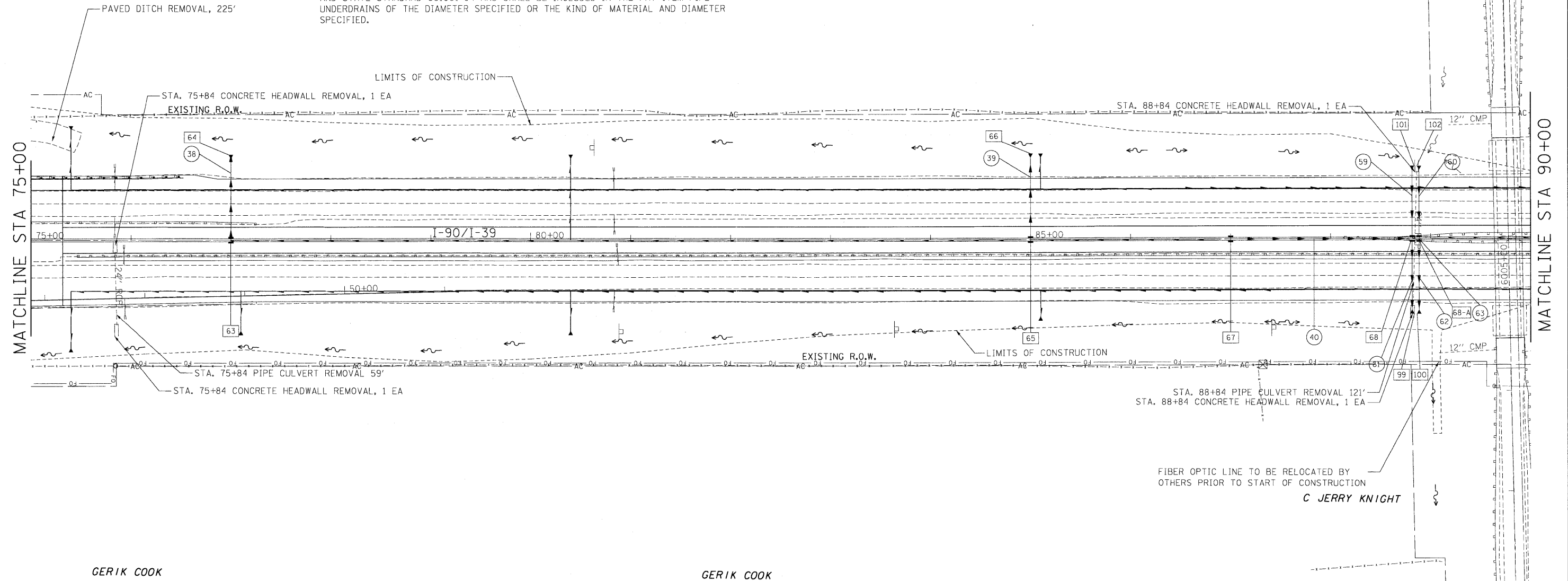

USER NAME = .USERNAME.	DESIGNED - DA	REVISED -
PLOT SCALE = 50.0000' / IN.	DRAWN - DA	REVISED -
PLOT DATE = 10/19/2011	CHECKED - AM	REVISED -
	DATE - 10/14/2011	REVISED -

STATE OF ILLINOIS
DEPARTMENT OF TRANSPORTATION

I-90 DRAINAGE PLANS

SCALE: SHEET NO. OF SHEETS STA. 75+00 TO STA. 90+00

F.A.I. RTE.	SECTION	COUNTY	TOTAL SHEETS	SHEET NO.
90	(X2-1R)	WINNEBAGO	510	236
CONTRACT NO. 64C29			ILLINOIS FED. AID PROJECT	



DRAINAGE STRUCTURE SCHEDULE

NO.	LOCATION		TYPE	RIM ELEV	INVERT ELEVATION		
	STATION	OFFSET			(IN)	(IN)	(OUT)
69	90+35	0.0	DR STR T4 W/2 T2OF&G	778.20			773.76
70	91+86	0.0	DR STR T4 W/2 T2OF&G	777.71	773.27		773.27
71	92+51	0.0	DR STR T5 W/2 T2F&G	777.60	773.06		772.79
72	93+16	0.0	DR STR T4 W/2 T2OF&G	777.71	773.01		773.01
73	93+16	78.3 LT	PRC FLAR END SEC 18	-			772.71
74	95+25	0.0	DR STR T4 W/2 T2OF&G	778.36			773.31
75	95+25	84.7 LT	PRC FLAR END SEC 18	-			772.17
76	96+90	0.0	DR STR T4 W/2 T2OF&G	780.70			774.35
77	96+90	99.1 LT	PRC FLAR END SEC 18	-			773.16
78	98+86	0.0	DR STR T4 W/2 T2OF&G	779.48			774.82
79	98+86	82.8 LT	PRC FLAR END SEC 18	-			774.59
80	101+23	0.0	DR STR T4 W/2 T2OF&G	780.21			775.54
81	101+23	82.8 LT	PRC FLAR END SEC 18	-			775.31
82	103+60	0.0	DR STR T4 W/2 T2OF&G	780.95			776.26
83	103+60	83.0 LT	PRC FLAR END SEC 18	-			776.03

STORM SEWERS SCHEDULE

SEWER NO.	TYPE	SIZE	LENGTH	SLOPE
		(INCH)	(FEET)	(%)
41	STORM SEW CL A 2	15	148.0	0.30%
42	STORM SEW CL A 2	15	61.0	0.30%
43	STORM SEW CL A 2	18	61.1	0.31%
44	STORM SEW CL A 2	18	68.7	0.40%
45	STORM SEW CL A 2	18	75.1	1.40%
46	STORM SEW CL A 2	18	89.5	1.25%
47	STORM SEW CL A 2	18	73.2	0.30%
48	STORM SEW CL A 2	18	73.3	0.30%
49	STORM SEW CL A 2	18	73.4	0.30%

JIM HEIDENREICH

LEGEND

- DRAINAGE STRUCTURES
- STORM SEWERS

UNDERDRAIN CONNECTION NOTE:

CONTRACTOR SHALL CONNECT THE PROPOSED PIPE UNDERDRAIN (OF DIAMETER SPECIFIED) TO THE PROPOSED INLET AT AN ELEVATION OF 2.50' BELOW THE RIM ELEVATION OF THE INLET BEING CONNECTED TO. THIS WORK SHALL BE IN ACCORDANCE WITH SECTION 601 OF THE STATE STANDARDS AND STATE STANDARD 601001-04 AND SHALL BE INCLUDED IN THE PAY ITEM PIPE UNDERDRAINS OF THE DIAMETER SPECIFIED OR THE KIND OF MATERIAL AND DIAMETER SPECIFIED.

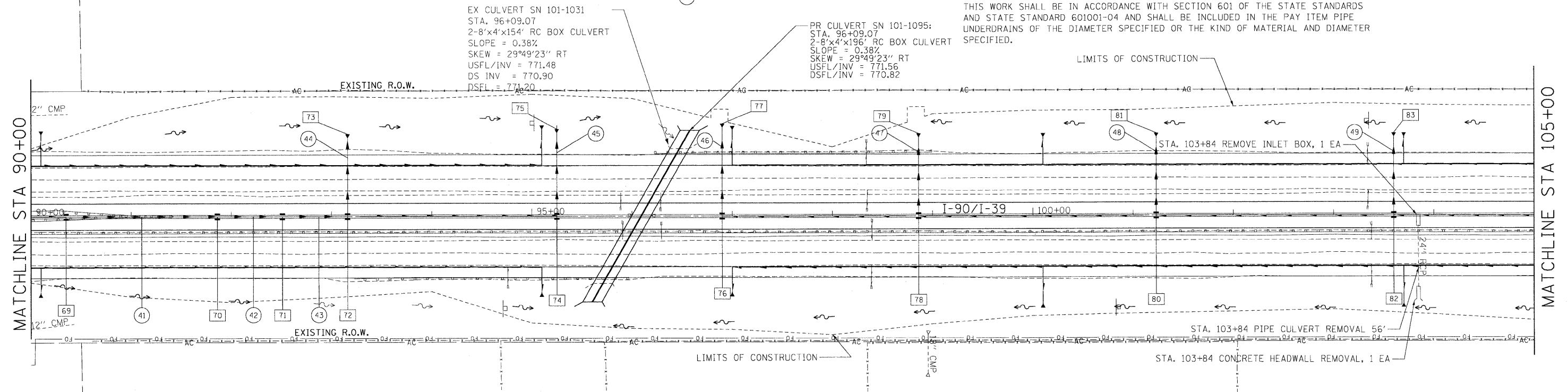

SUNIL ILLINOIS LLC

EDWARD KRULL

TONY H & SALLY Y KWOK

EDWARD KRULL

NYMAN PROPERTIES LLC

NYMAN PROPERTIES LLC

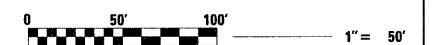

USER NAME = .USERNAME.	DESIGNED - DA	REVISED -
PLOT SCALE = 50.0000' / IN.	DRAWN - DA	REVISED -
PLOT DATE = 12/19/2011	CHECKED - AM	REVISED -
	DATE - 10/14/2011	REVISED -

STATE OF ILLINOIS
DEPARTMENT OF TRANSPORTATION

I-90 DRAINAGE PLANS

SCALE: SHEET NO. OF SHEETS STA. 90+00 TO STA. 105+00

F.A.I. RTE. 90	SECTION (X2-1)R	COUNTY WINNEBAGO	TOTAL SHEETS 510	SHEET NO. 237
			CONTRACT NO. 64C29	
ILLINOIS FED. AID PROJECT				



DRAINAGE STRUCTURE SCHEDULE

NO.	LOCATION		TYPE	RIM ELEV.	INVERT ELEVATION			
	STATION	OFFSET			(IN)	(IN)	(IN)	(OUT)
84	105+97	0.0	DR STR T4 W/2 T2OF&G	781.68				776.98
85	105+97	83.0 LT	PRC FLAR END SEC 18	-				776.75
86	108+34	0.0	DR STR T4 W/2 T2OF&G	782.42				777.70
87	108+34	83.1 LT	PRC FLAR END SEC 18	-				777.47
88	110+71	0.0	DR STR T4 W/2 T2OF&G	783.15				778.43
89	110+71	83.1 LT	PRC FLAR END SEC 18	-				778.20
90	113+08	0.0	DR STR T4 W/2 T2OF&G	783.89				779.16
91	113+08	83.3 LT	PRC FLAR END SEC 18	-				778.92
92	115+45	0.0	DR STR T4 W/2 T2OF&G	784.62				779.89
93	115+48	83.3 LT	PRC FLAR END SEC 18	-				779.65

STORM SEWERS SCHEDULE

SEWER NO.	TYPE	SIZE	LENGTH	SLOPE
		(INCH)	(FEET)	(%)
50	STORM SEW CL A 2	18	73.4	0.30%
51	STORM SEW CL A 2	18	73.6	0.30%
52	STORM SEW CL A 2	18	73.6	0.30%
53	STORM SEW CL A 2	18	73.7	0.30%
54	STORM SEW CL A 2	18	73.7	0.30%

LEGEND

- DRAINAGE STRUCTURES
- STORM SEWERS

UNDERDRAIN CONNECTION NOTE:

CONTRACTOR SHALL CONNECT THE PROPOSED PIPE UNDERDRAIN (OF DIAMETER SPECIFIED) TO THE PROPOSED INLET AT AN ELEVATION OF 2.50' BELOW THE RIM ELEVATION OF THE INLET BEING CONNECTED TO. THIS WORK SHALL BE IN ACCORDANCE WITH SECTION 601 OF THE STATE STANDARDS AND STATE STANDARD 601001-04 AND SHALL BE INCLUDED IN THE PAY ITEM PIPE UNDERDRAINS OF THE DIAMETER SPECIFIED OR THE KIND OF MATERIAL AND DIAMETER SPECIFIED.

JIM HEIDENREICH

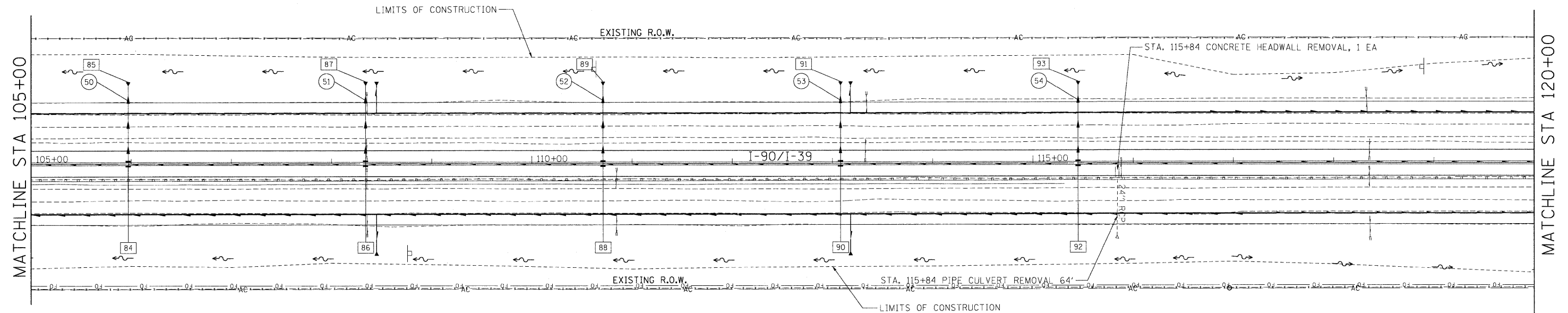

NYMAN PROPERTIES LLC

ITC PARTNERS LLC

AUXII & ASSOCIATES INC, TRUSTEE

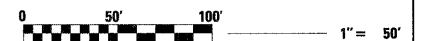

USER NAME = .USERNAME.
 DESIGNED - DA
 DRAWN - DA
 CHECKED - AM
 DATE - 10/14/2011
 PLOT SCALE = 50.0000' / IN.
 PLOT DATE = 10/19/2011

REVISED -
 REVISED -
 REVISED -
 REVISED -

STATE OF ILLINOIS
 DEPARTMENT OF TRANSPORTATION

I-90 DRAINAGE PLANS

SCALE: SHEET NO. OF SHEETS STA. 105+00 TO STA. 120+00

F.A.I. RTE.	SECTION	COUNTY	TOTAL SHEETS	SHEET NO.
90	(X2-1)R	WINNEBAGO	510	238
CONTRACT NO. 64C29				
ILLINOIS FED. AID PROJECT				



DRAINAGE STRUCTURE SCHEDULE

NO.	LOCATION		TYPE	RIM ELEV LT	RIM ELEV RT	INVERT ELEVATION			
	STATION	OFFSET				(IN)	(IN)	(IN)	(OUT)
94	125+40	0.0	DR STR T4 W/2 T20F&G	784.67	784.59				779.88
95	127+77	0.0	DR STR T4 W/2 T20F&G	783.96	783.85	779.08			778.54
96	130+14	0.0	DR STR T4 W/2 T20F&G	783.25	783.10	777.83			777.83
97	132+51	0.0	DR STR T4 SPL W/2 T20F&G	782.55	782.36	777.13			776.38
98	132+51	118.6 RT	PRC FLAR END SEC 24	-	-				775.23

LEGEND

- DRAINAGE STRUCTURES
- STORM SEWERS

UNDERDRAIN CONNECTION NOTE:

CONTRACTOR SHALL CONNECT THE PROPOSED PIPE UNDERDRAIN (OF DIAMETER SPECIFIED) TO THE PROPOSED INLET AT AN ELEVATION OF 2.50' BELOW THE RIM ELEVATION OF THE INLET BEING CONNECTED TO. THIS WORK SHALL BE IN ACCORDANCE WITH SECTION 601 OF THE STATE STANDARDS AND STATE STANDARD 601001-04 AND SHALL BE INCLUDED IN THE PAY ITEM PIPE UNDERDRAINS OF THE DIAMETER SPECIFIED OR THE KIND OF MATERIAL AND DIAMETER SPECIFIED.

SCHROEDER BELOIT LLC

STORM SEWERS SCHEDULE

SEWER (NO.)	TYPE	SIZE	LENGTH	SLOPE
		(INCH)	(FEET)	(%)
55	STORM SEW CL A 2	18	234.0	0.34%
56	STORM SEW CL A 2	24	234.0	0.30%
57	STORM SEW CL A 2	24	233.5	0.30%
58	STORM SEW CL A 2	24	109.0	1.00%

JIM HEIDENREICH

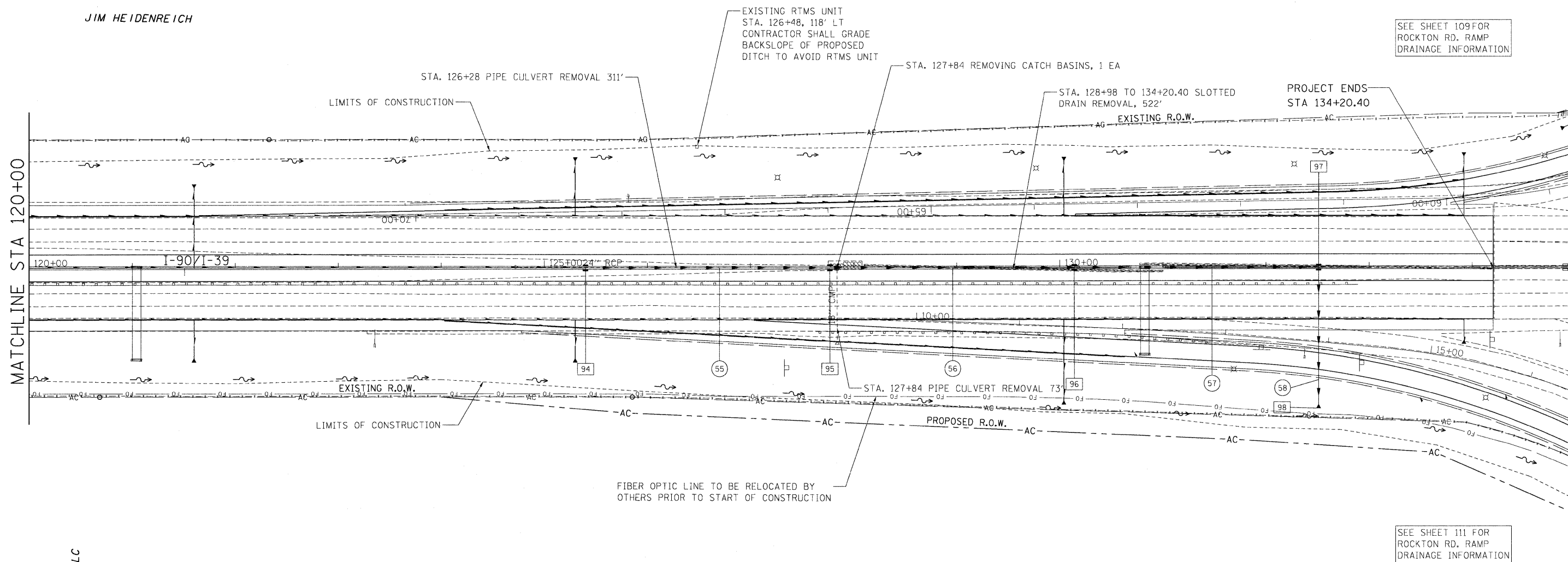

SEE SHEET 109 FOR ROCKTON RD. RAMP DRAINAGE INFORMATION

SEE SHEET 111 FOR ROCKTON RD. RAMP DRAINAGE INFORMATION

FIBER OPTIC LINE TO BE RELOCATED BY OTHERS PRIOR TO START OF CONSTRUCTION

ITC PARTNERS LLC

AUXI & ASSOCIATES INC, TRUSTEE



USER NAME = .USERNAME.	DESIGNED - DA	REVISED -
	DRAWN - DA	REVISED -
PLOT SCALE = 50.0000' / IN.	CHECKED - AM	REVISED -
PLOT DATE = 10/19/2011	DATE - 10/14/2011	REVISED -

STATE OF ILLINOIS
DEPARTMENT OF TRANSPORTATION

I-90 DRAINAGE PLANS

SCALE: SHEET NO. OF SHEETS STA. 120+00 TO STA. 135+00

F.A.I. RTE. 90	SECTION (X2-1)R	COUNTY WINNEBAGO	TOTAL SHEETS 510	SHEET NO. 239
				CONTRACT NO. 64C29
ILLINOIS FED. AID PROJECT				



SCHROEDER BELOIT LLC

LIMITS OF CONSTRUCTION

SEE SHEET 109 FOR
ROCKTON RD. RAMP
DRAINAGE INFORMATION

MATCHLINE STA 135+00

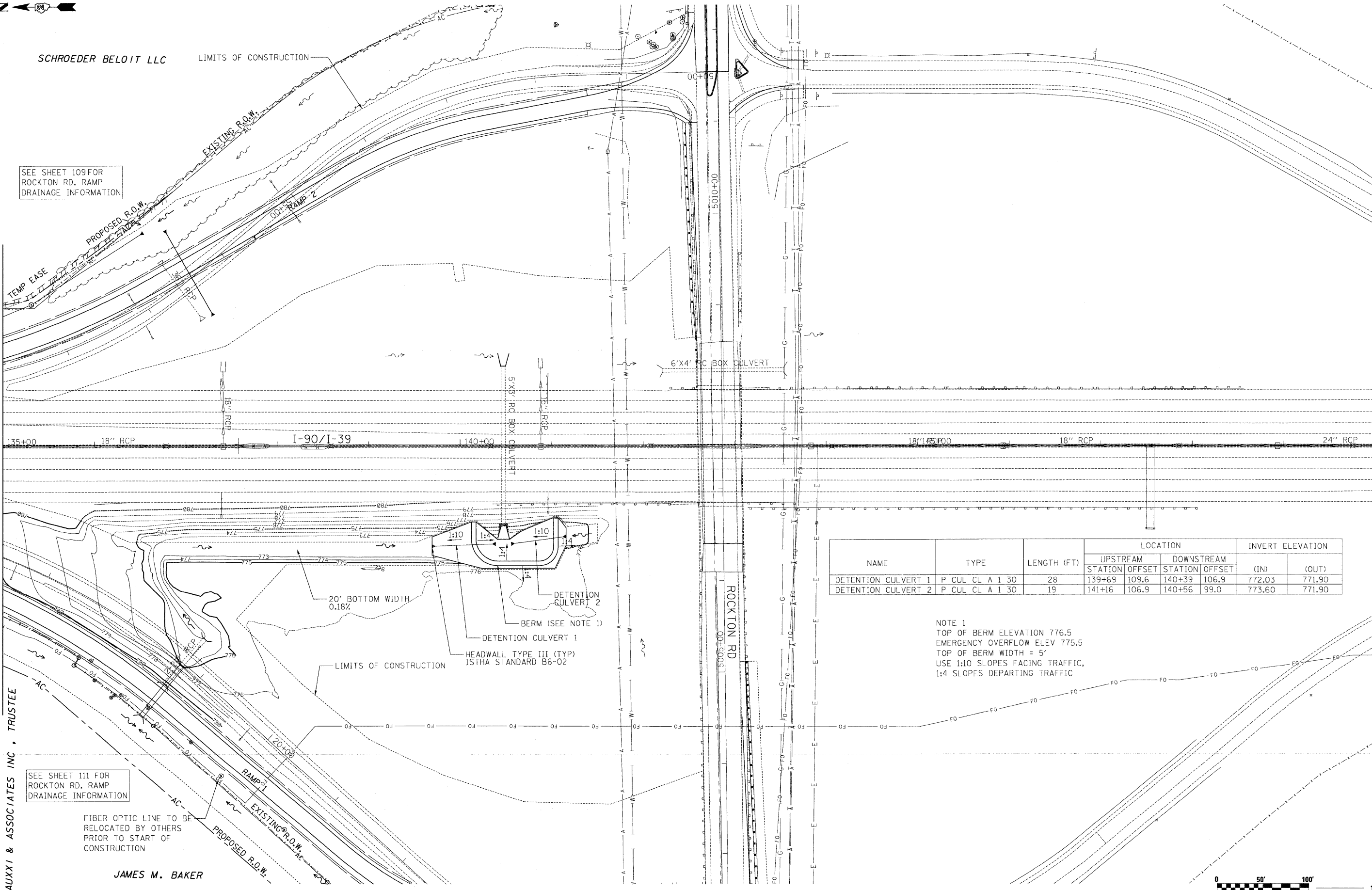

NAME	TYPE	LENGTH (FT)	LOCATION				INVERT ELEVATION	
			UPSTREAM STATION	UPSTREAM OFFSET	DOWNSTREAM STATION	DOWNSTREAM OFFSET	(IN)	(OUT)
DETENTION CULVERT 1	P CUL CL A 1 30	28	139+69	109.6	140+39	106.9	772.03	771.90
DETENTION CULVERT 2	P CUL CL A 1 30	19	141+16	106.9	140+56	99.0	773.60	771.90

NOTE 1
TOP OF BERM ELEVATION 776.5
EMERGENCY OVERFLOW ELEV 775.5
TOP OF BERM WIDTH = 5'
USE 1:10 SLOPES FACING TRAFFIC,
1:4 SLOPES DEPARTING TRAFFIC



AUXI & ASSOCIATES INC., TRUSTEE

SEE SHEET 111 FOR
ROCKTON RD. RAMP
DRAINAGE INFORMATION

FIBER OPTIC LINE TO BE
RELOCATED BY OTHERS
PRIOR TO START OF
CONSTRUCTION

JAMES M. BAKER



USER NAME = .USERNAME.
DESIGNED - DA
DRAWN - DA
CHECKED - AM
DATE - 10/14/2011

REVISED -
REVISED -
REVISED -
REVISED -

REVISIONS

STATE OF ILLINOIS
DEPARTMENT OF TRANSPORTATION

I-90 DRAINAGE PLANS

SCALE: SHEET NO. OF SHEETS STA. 135+00 TO STA. 150+00

F.A.I. RTE. 90	SECTION (X2-1)R	COUNTY WINNEBAGO	TOTAL SHEETS 510	SHEET NO. 240
CONTRACT NO. 64C29				
ILLINOIS FED. AID PROJECT				

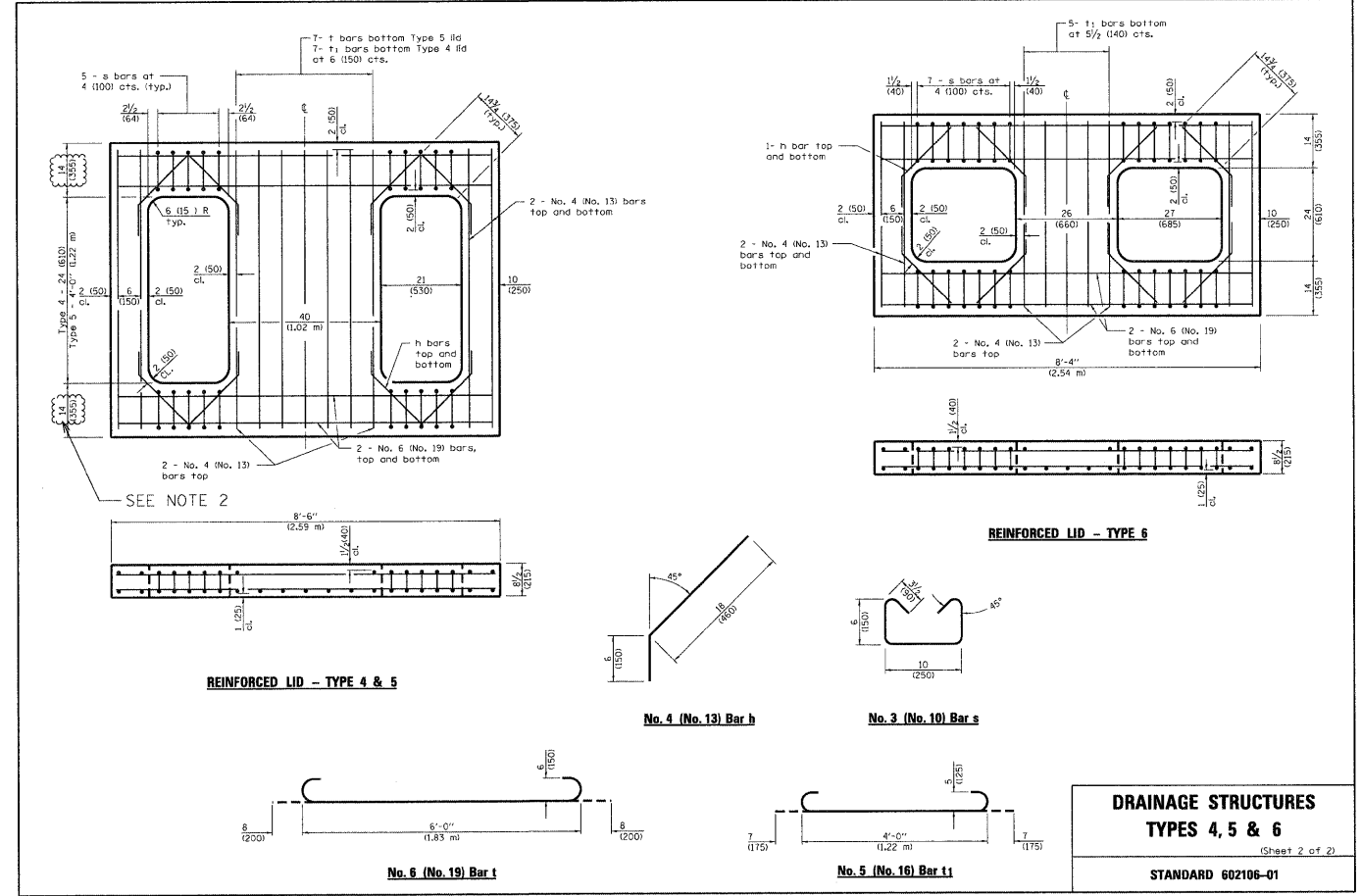
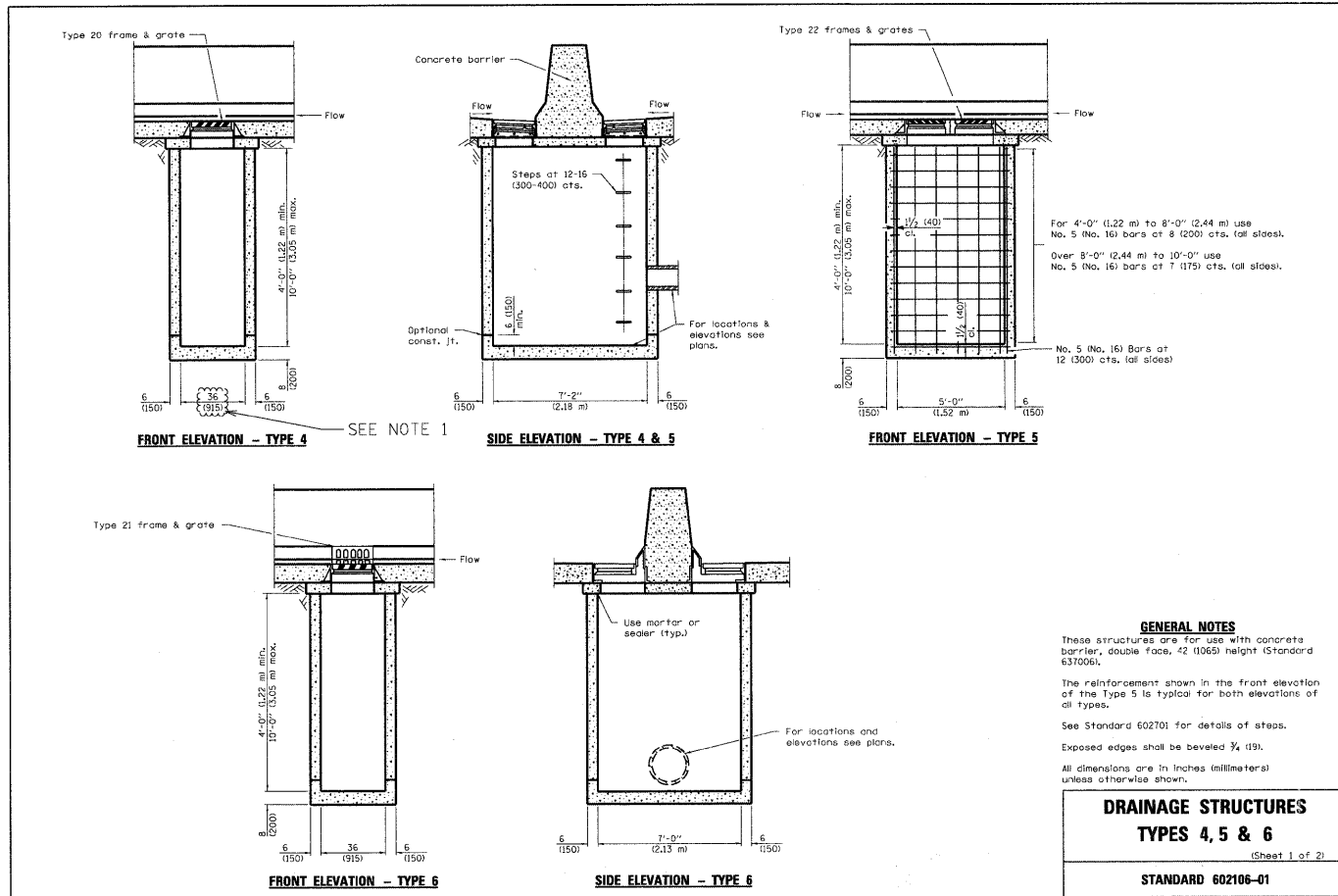

DRAINAGE STRUCTURE TYPE 4 SPECIAL NOTES

DRAINAGE STRUCTURES TYPE 4 (SPECIAL) ARE USED FOR SEWERS LARGER THAN 18 INCHES ENTERING/EXITING THE FRONT OF THE STRUCTURE AT THE LOCATIONS SHOWN ON PLANS.

NOTE 1:
 THE 36 INCH DIMENSION SHOWN ON THE STANDARD SHALL BE 48 INCHES FOR THE DRAINAGE STRUCTURES TYPE 4 SPECIAL.

NOTE 2:
 THE 14 INCH DIMENSION SHOWN ON THE STANDARD SHALL BE 20 INCHES FOR THE DRAINAGE STRUCTURES TYPE 4 SPECIAL.

THE CONTRACTOR IS RESPONSIBLE FOR THE MODIFICATIONS NEEDED FOR THE REINFORCEMENT BARS DUE TO THIS CHANGE IN DIMENSION (FROM 14 INCHES TO 20 INCHES) FOR THE REINFORCED LID.

BEFORE BEGINNING FABRICATION, THE CONTRACTOR SHALL SUBMIT SHOP DRAWINGS TO THE ENGINEER FOR APPROVAL. THE SHOP DRAWINGS SHALL BE SIGNED BY AND BEARING THE SEAL OF A STRUCTURAL ENGINEER.

PHASE I CONSTRUCTION (WESTBOUND I-90 AND THE ROCKTON ROAD ON RAMP) IS PLANNED TO BE COMPLETED WITHIN ONE CONSTRUCTION SEASON. PAVEMENT MARKING FOR PHASE I WORK WILL BE PAINT, WHICH WILL BE TEMPORARILY REMOVED AT THE START OF THE FOLLOWING CONSTRUCTION SEASON.

URETHANE PAVEMENT MARKINGS SHALL BE INSTALLED WITHIN GROOVING FOR RECESSED PAVEMENT MARKINGS. RECESSED GROOVING SHALL BE 1" WIDER THAN THE WIDTH OF THE URETHANE PAVEMENT MARKINGS.

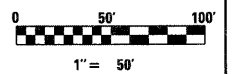
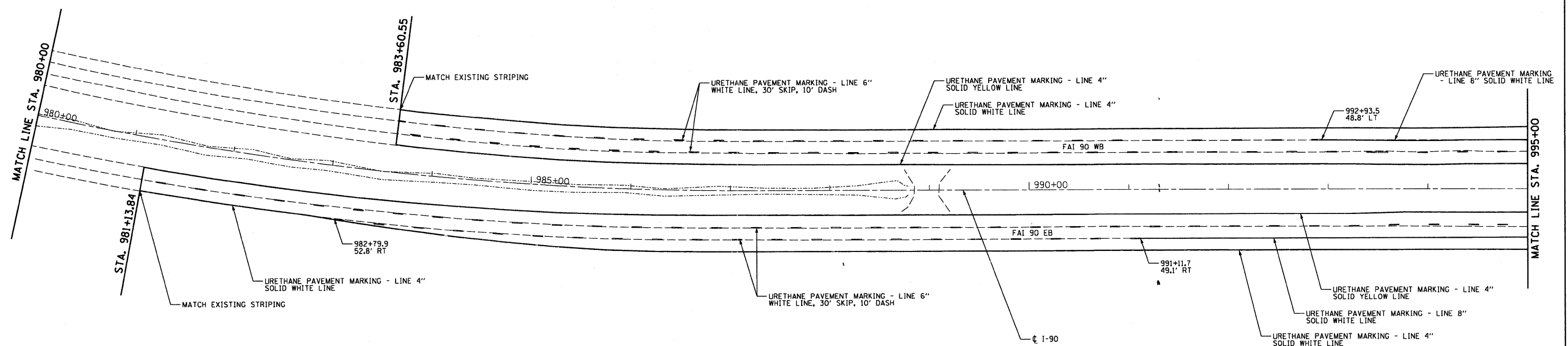

McClure LOCHNER
Engineering Associates, Inc.
Civil Engineering Consultants
RWA
Ralph W. Anderson & Associates, Inc.
OEI
Quigley Engineering, Inc.

USER NAME = .USERNAME.	DESIGNED -	REVISED -
FILE NAME = #FILE#	DRAWN - BSL	REVISED -
PLOT SCALE = 50.0000' / IN.	CHECKED - PDS	REVISED -
PLOT DATE = 10/19/2011	DATE - 10-21-2011	REVISED -

**STATE OF ILLINOIS
DEPARTMENT OF TRANSPORTATION**

PAVEMENT MARKING PLANS I-90 MAINLINE			
SCALE:	SHEET NO. OF SHEETS	STA. 980+00 TO STA. 995+00	

F.A. RTE. 90	SECTION (X2-1) R	COUNTY WINNEBAGO	TOTAL SHEETS 510	SHEET NO. 242
CONTRACT NO. 64C29				
ILLINOIS FED. AID PROJECT				

PHASE I CONSTRUCTION (WESTBOUND I-90 AND THE ROCKTON ROAD ON RAMP) IS PLANNED TO BE COMPLETED WITHIN ONE CONSTRUCTION SEASON. PAVEMENT MARKING FOR PHASE I WORK WILL BE PAINT, WHICH WILL BE TEMPORARILY REMOVED AT THE START OF THE FOLLOWING CONSTRUCTION SEASON.

URETHANE PAVEMENT MARKINGS SHALL BE INSTALLED WITHIN GROOVING FOR RECESSED PAVEMENT MARKINGS. RECESSED GROOVING SHALL BE 1" WIDER THAN THE WIDTH OF THE URETHANE PAVEMENT MARKINGS.

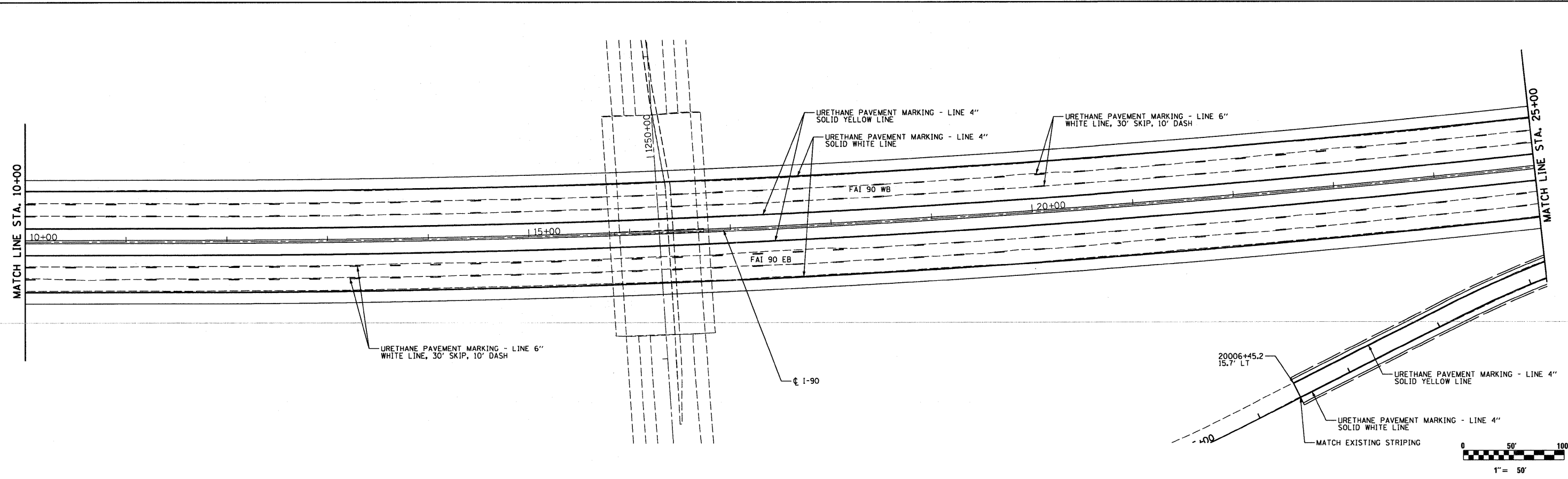
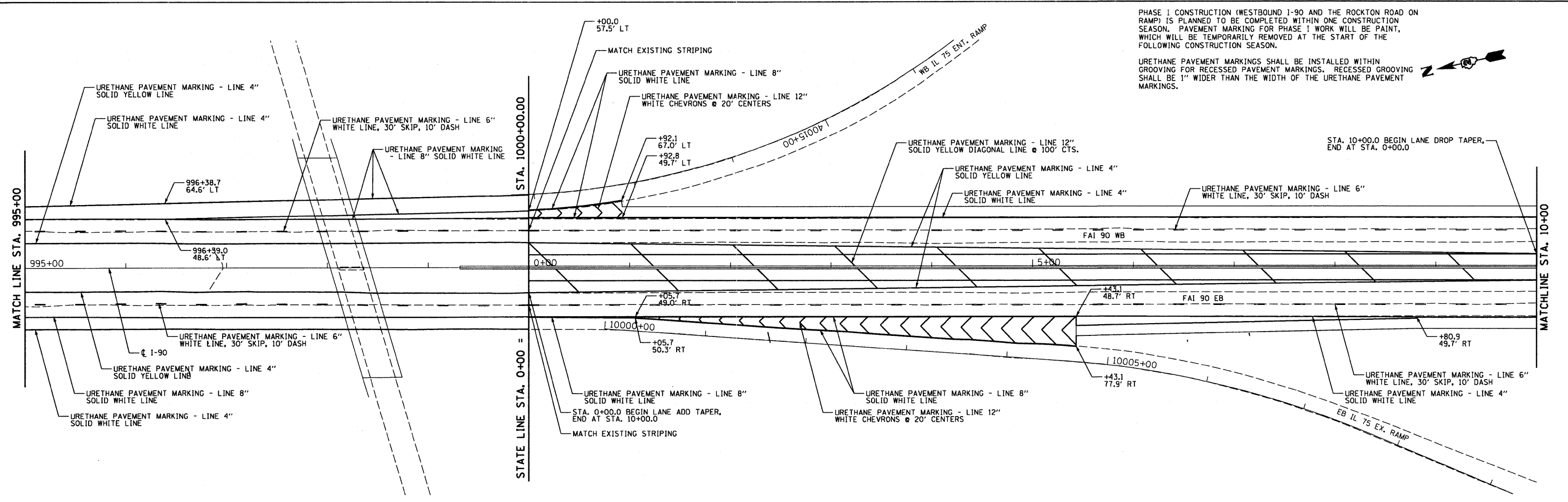
McClure LOCHNER
Engineering Associates, Inc.
CIVIL ENGINEERING CONSULTANTS
RWA
Regina W. Adams & Associates, Inc.

USER NAME = .USERNAME.	DESIGNED -	REVISED -
FILE NAME = #FILE#	DRAWN - BSL	REVISED -
PLOT SCALE = 50.0000" / IN.	CHECKED - PDS	REVISED -
PLOT DATE = 10/19/2011	DATE - 10-21-2011	REVISED -

**STATE OF ILLINOIS
DEPARTMENT OF TRANSPORTATION**

PAVEMENT MARKING PLANS I-90 MAINLINE & RAMPS

SCALE: H: 1"=100'	V: 1"=10'	SHEET NO. OF SHEETS	STA. 995+00 TO STA. 25+00
-------------------	-----------	---------------------	---------------------------

F.A. RTE. 90	SECTION (X2-1) R	COUNTY WINNEBAGO	TOTAL SHEETS 510	SHEET NO. 243
CONTRACT NO. 64C29				
ILLINOIS FED. AID PROJECT				

PHASE I CONSTRUCTION (WESTBOUND I-90 AND THE ROCKTON ROAD ON RAMP) IS PLANNED TO BE COMPLETED WITHIN ONE CONSTRUCTION SEASON. PAVEMENT MARKING FOR PHASE I WORK WILL BE PAINT, WHICH WILL BE TEMPORARILY REMOVED AT THE START OF THE FOLLOWING CONSTRUCTION SEASON.

URETHANE PAVEMENT MARKINGS SHALL BE INSTALLED WITHIN GROOVING FOR RECESSED PAVEMENT MARKINGS. RECESSED GROOVING SHALL BE 1" WIDER THAN THE WIDTH OF THE URETHANE PAVEMENT MARKINGS.

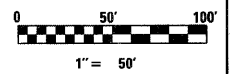
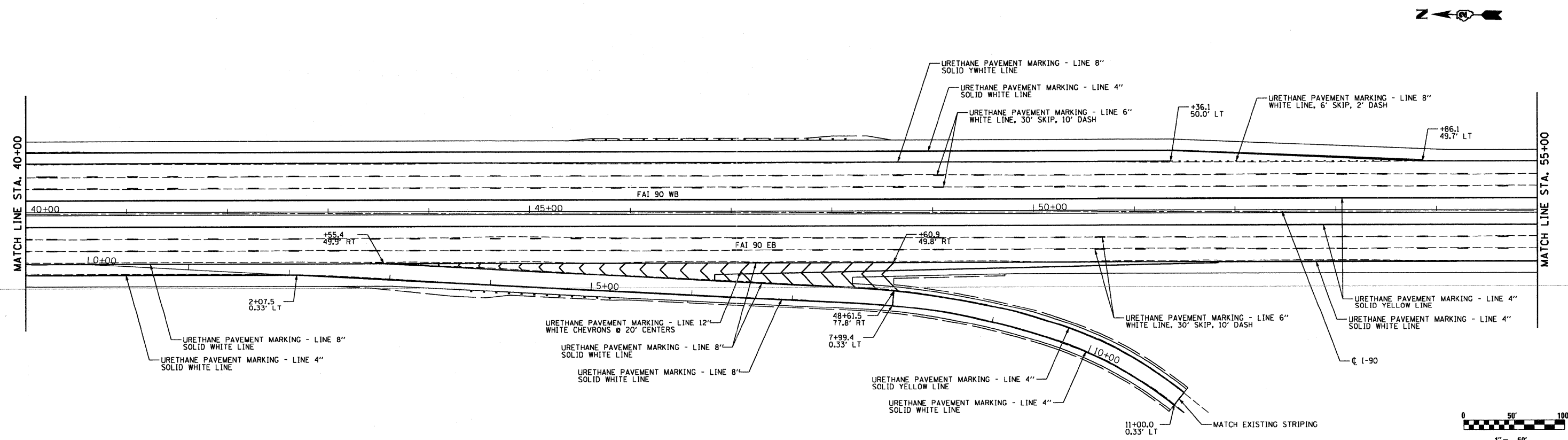
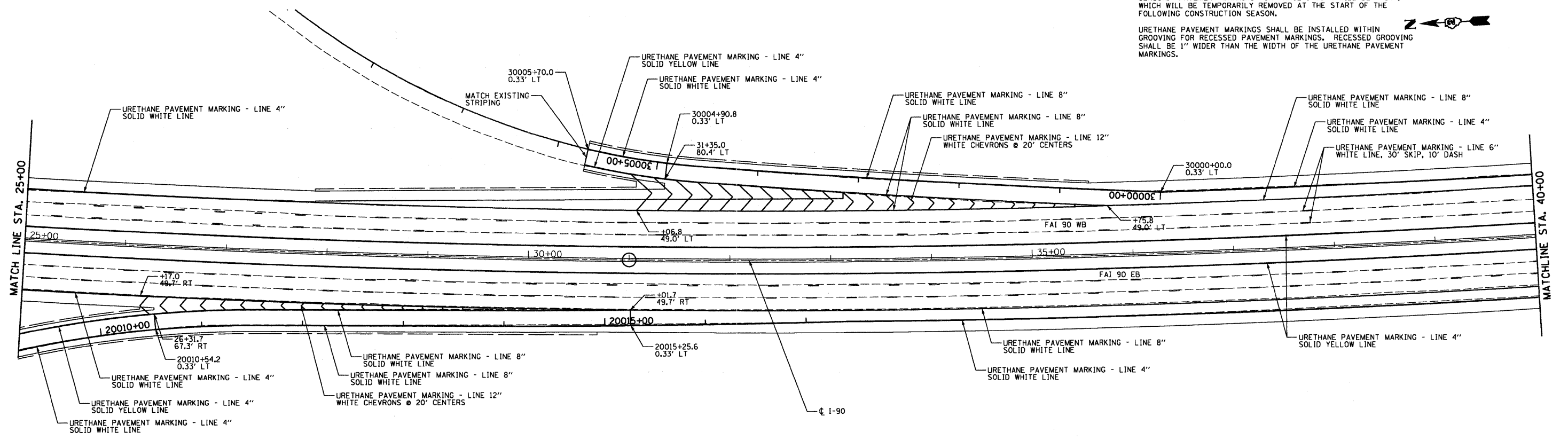

McClure LOCHNER
Engineering Architects, Inc.
RWA
Regional Wholesale & Associates, Inc.

USER NAME = .USERNAME.	DESIGNED -	REVISED -
FILE NAME = #FILE#	DRAWN - BSL	REVISED -
PLOT SCALE = 50.0000' / IN.	CHECKED - PDS	REVISED -
PLOT DATE = 10/19/2011	DATE - 10-21-2011	REVISED -

**STATE OF ILLINOIS
DEPARTMENT OF TRANSPORTATION**

PAVEMENT MARKING PLANS I-90 MAINLINE & RAMPS

SCALE: SHEET NO. OF SHEETS STA. 25+00 TO STA. 55+00

F.A. RTE.	SECTION	COUNTY	TOTAL SHEETS	SHEET NO.
90	(X2-1) R	WINNEBAGO	510	244
CONTRACT NO. 64C29				
ILLINOIS FED. AID PROJECT				

PHASE I CONSTRUCTION (WESTBOUND I-90 AND THE ROCKTON ROAD ON RAMP) IS PLANNED TO BE COMPLETED WITHIN ONE CONSTRUCTION SEASON. PAVEMENT MARKING FOR PHASE I WORK WILL BE PAINT, WHICH WILL BE TEMPORARILY REMOVED AT THE START OF THE FOLLOWING CONSTRUCTION SEASON.

URETHANE PAVEMENT MARKINGS SHALL BE INSTALLED WITHIN GROOVING FOR RECESSED PAVEMENT MARKINGS. RECESSED GROOVING SHALL BE 1" WIDER THAN THE WIDTH OF THE URETHANE PAVEMENT MARKINGS.

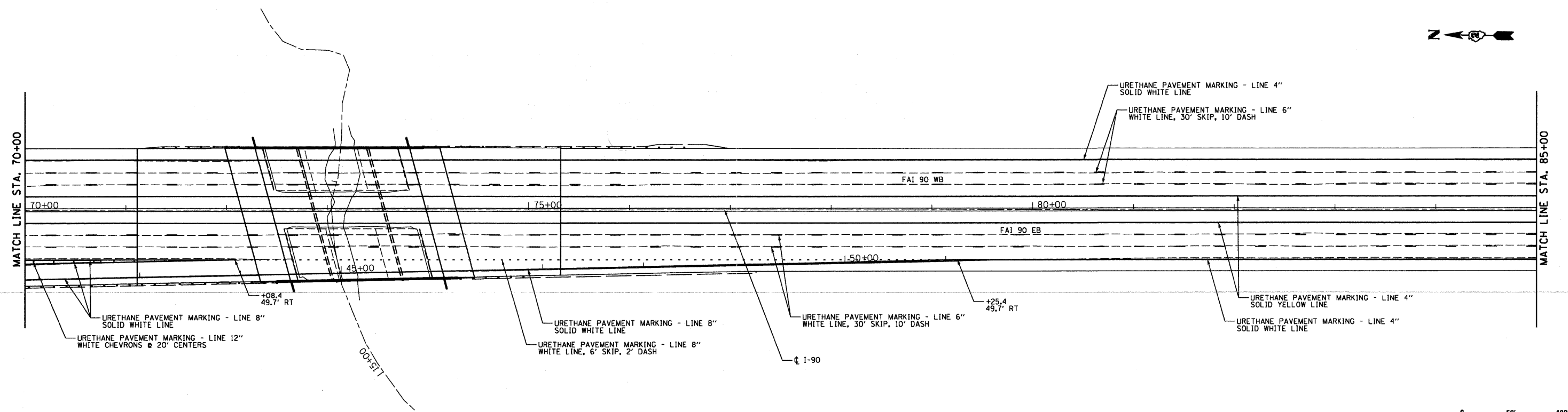
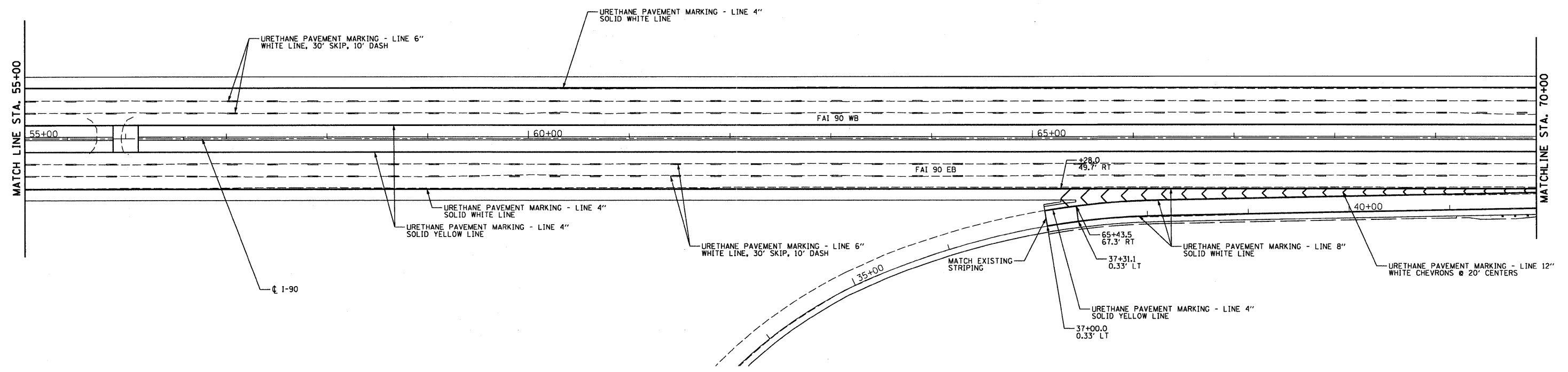

McClure LOCHNER
Engineering Associates, Inc.
RWA
REGISTERED ARCHITECTS & ENGINEERS, INC.
OEI
QUIGG ENGINEERING, INC.

USER NAME = .USERNAME.	DESIGNED -	REVISED -
FILE NAME = \$FILE\$	DRAWN - BSL	REVISED -
PLOT SCALE = 50.0000' / IN.	CHECKED - PDS	REVISED -
PLOT DATE = 10/19/2011	DATE - 10-21-2011	REVISED -

**STATE OF ILLINOIS
DEPARTMENT OF TRANSPORTATION**

PAVEMENT MARKING PLANS I-90 MAINLINE & RAMPS				
SCALE:	SHEET NO.	OF SHEETS	STA. 55+00	TO STA. 85+00

F.A. RTE. 90	SECTION (X2-1) R	COUNTY WINNEBAGO	TOTAL SHEETS 510	SHEET NO. 245
CONTRACT NO. 64C29				
ILLINOIS FED. AID PROJECT				

PHASE I CONSTRUCTION (WESTBOUND I-90 AND THE ROCKTON ROAD ON RAMP) IS PLANNED TO BE COMPLETED WITHIN ONE CONSTRUCTION SEASON. PAVEMENT MARKING FOR PHASE I WORK WILL BE PAINT, WHICH WILL BE TEMPORARILY REMOVED AT THE START OF THE FOLLOWING CONSTRUCTION SEASON.



URETHANE PAVEMENT MARKINGS SHALL BE INSTALLED WITHIN GROOVING FOR RECESSED PAVEMENT MARKINGS. RECESSED GROOVING SHALL BE 1" WIDER THAN THE WIDTH OF THE URETHANE PAVEMENT MARKINGS.

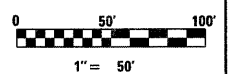
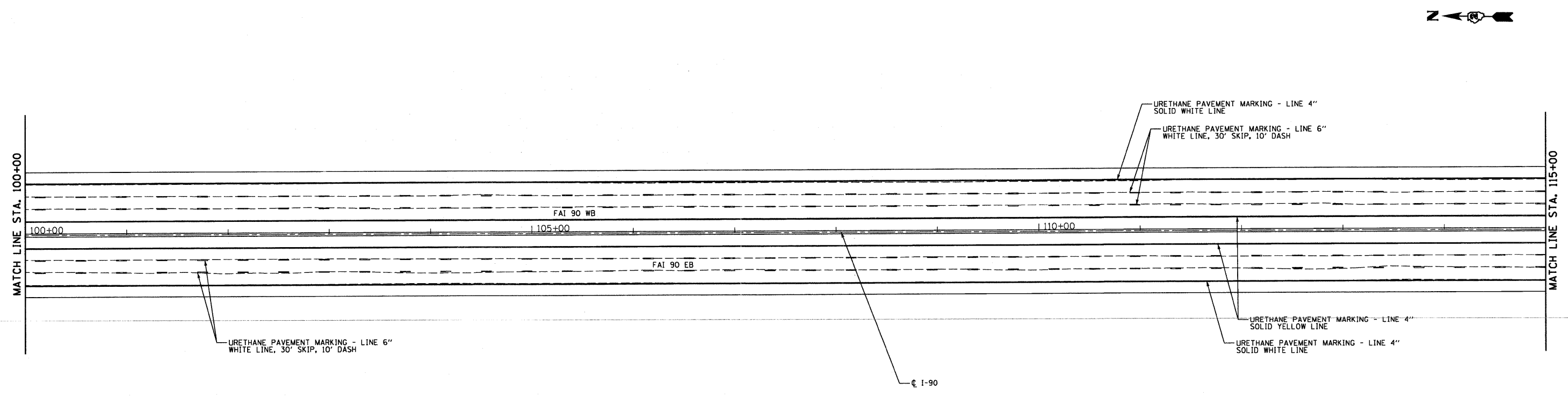
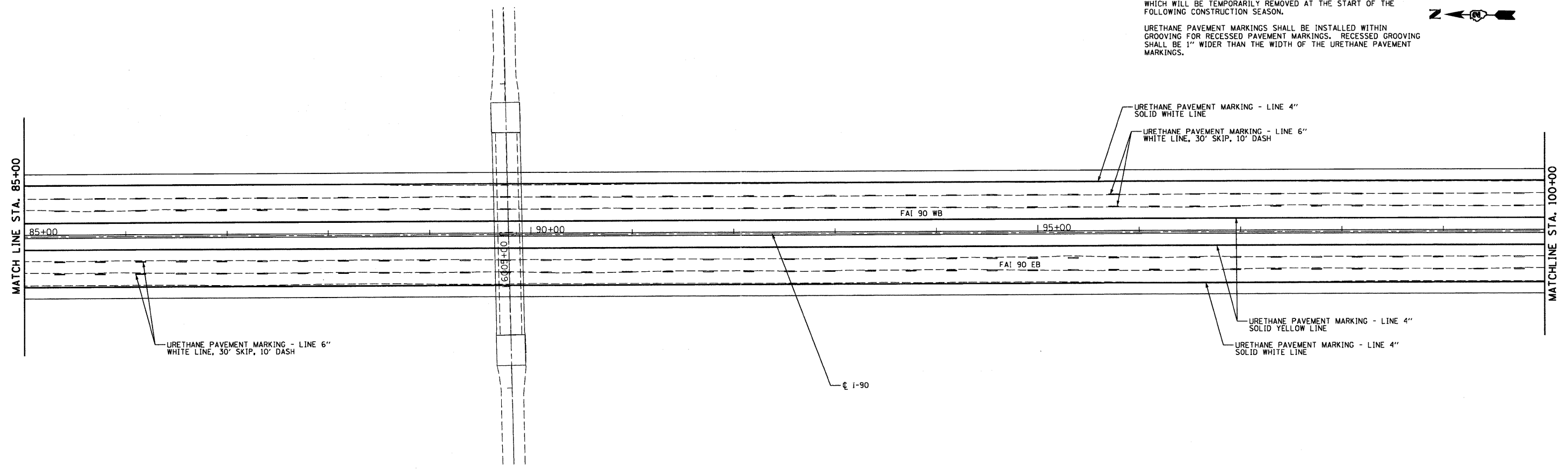

McClure LOCHNER
Engineering Consultants, Inc.
RVA
Engineering & Associates, Inc.

USER NAME = .USERNAME.
FILE NAME = #FILE#
PLOT SCALE = 50.0000' / IN.
PLOT DATE = 10/19/2011

DESIGNED -
DRAWN - BSL
CHECKED - PDS
DATE - 10-21-2011

REVISED -
REVISED -
REVISED -
REVISED -

**STATE OF ILLINOIS
DEPARTMENT OF TRANSPORTATION**

PAVEMENT MARKING PLANS I-90 MAINLINE & RAMPS

SCALE: SHEET NO. OF SHEETS STA. 85+00 TO STA. 115+00

F.A. RTE. 90	SECTION (X2-1) R	COUNTY WINNEBAGO	TOTAL SHEETS 510	SHEET NO. 246
CONTRACT NO. 64C29				
ILLINOIS FED. AID PROJECT				

PHASE I CONSTRUCTION (WESTBOUND I-90 AND THE ROCKTON ROAD ON RAMP) IS PLANNED TO BE COMPLETED WITHIN ONE CONSTRUCTION SEASON. PAVEMENT MARKING FOR PHASE I WORK WILL BE PAINT, WHICH WILL BE TEMPORARILY REMOVED AT THE START OF THE FOLLOWING CONSTRUCTION SEASON.

URETHANE PAVEMENT MARKINGS SHALL BE INSTALLED WITHIN GROOVING FOR RECESSED PAVEMENT MARKINGS. RECESSED GROOVING SHALL BE 1" WIDER THAN THE WIDTH OF THE URETHANE PAVEMENT MARKINGS.

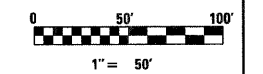
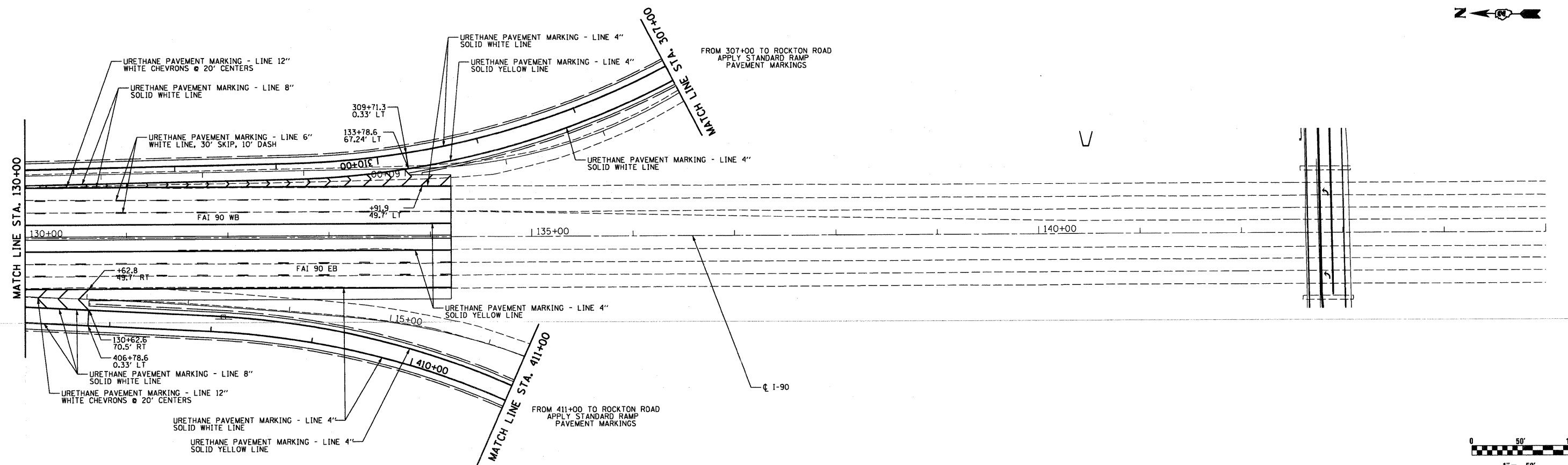
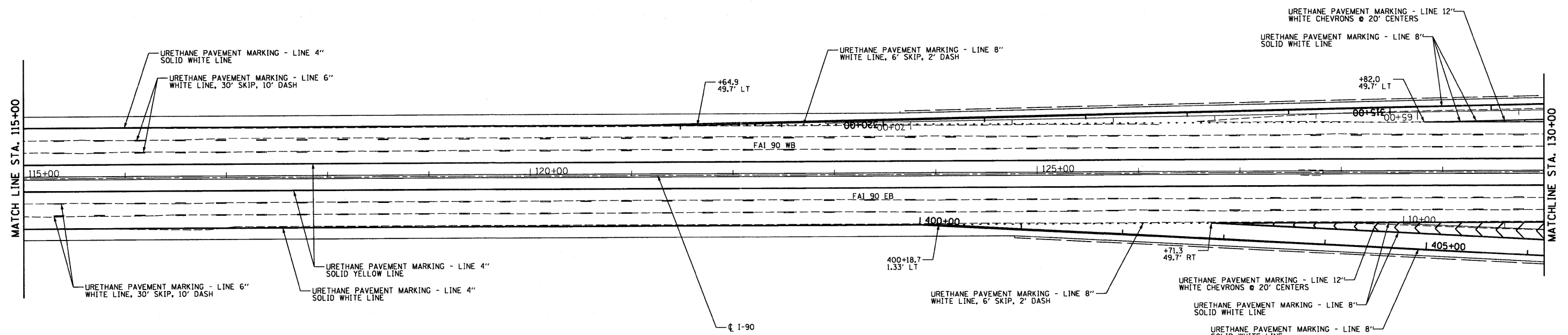

McClure LOCHNER
ENGINEERING CONSULTANTS
RWA
REGISTERED PROFESSIONAL ENGINEERS
OEI
QUINCY ENGINEERS, INC.

USER NAME = .USERNAME.	DESIGNED -	REVISED -
FILE NAME = #FILE#	DRAWN - BSL	REVISED -
PLOT SCALE = 50.0000' / IN.	CHECKED - PDS	REVISED -
PLOT DATE = 10/19/2011	DATE - 10-21-2011	REVISED -

**STATE OF ILLINOIS
DEPARTMENT OF TRANSPORTATION**

PAVEMENT MARKING PLANS I-90 MAINLINE & RAMPS

SCALE:	SHEET NO. OF SHEETS	STA. 115+00 TO STA. 145+00
--------	---------------------	----------------------------

F.A. RTE.	SECTION	COUNTY	TOTAL SHEETS	SHEET NO.
90	(X2-1) R	WINNEBAGO	510	247
CONTRACT NO. 64C29				
[ILLINOIS] FED. AID PROJECT				

**TOLLWAY PAVEMENT MARKING PLANS
NOT INCLUDED IN THIS SUBMITTAL**

	USER NAME = .USERNAME.	DESIGNED -	REVISED -	STATE OF ILLINOIS DEPARTMENT OF TRANSPORTATION	LIGHTING PLAN OVERHEAD SIGN STRUCTURE	F.A.I. RTE.	SECTION	COUNTY	TOTAL SHEETS	SHEET NO.
	PLOT SCALE = 50.0000' / IN.	DRAWN - JPW	REVISED -			90	(X2-1)R	WINNEBAGO	510	249
	PLOT DATE = 10/19/2011	CHECKED -	REVISED -		SCALE:	SHEET NO. OF SHEETS STA. TO STA.		ILLINOIS FED. AID PROJECT CONTRACT NO. 64C29		
		DATE - 10/14/11	REVISED -							

**TOLLWAY PAVEMENT MARKING PLANS
NOT INCLUDED IN THIS SUBMITTAL**



USER NAME = ..USERNAME..	DESIGNED -	REVISED -
	DRAWN - JPW	REVISED -
PLOT SCALE = 50.0000' / IN.	CHECKED -	REVISED -
PLOT DATE = 10/19/2011	DATE - 10/14/11	REVISED -

**STATE OF ILLINOIS
DEPARTMENT OF TRANSPORTATION**

**LIGHTING PLAN
OVERHEAD SIGN STRUCTURE**

SCALE: SHEET NO. OF SHEETS STA. TO STA.



F.A.I. RTE.	SECTION	COUNTY	TOTAL SHEETS	SHEET NO.
90	(X2-1)R	WINNEBAGO	510	250
CONTRACT NO. 64C29				

ILLINOIS FED. AID PROJECT

**TOLLWAY PAVEMENT MARKING PLANS
NOT INCLUDED IN THIS SUBMITTAL**

		USER NAME = .USERNAME.	DESIGNED -	REVISED -	STATE OF ILLINOIS DEPARTMENT OF TRANSPORTATION	LIGHTING PLAN OVERHEAD SIGN STRUCTURE	F.A.I. RTE.	SECTION	COUNTY	TOTAL SHEETS	SHEET NO.
		PLOT SCALE = 50.0000 ' / IN.	DRAWN - JPW	REVISED -			90	(X2-1)R	WINNEBAGO	510	251
PLOT DATE = 10/19/2011	CHECKED -	REVISED -	CONTRACT NO. 64C29								
DATE - 10/14/11	REVISD -	REVISED -	ILLINOIS FED. AID PROJECT								
						SCALE:	SHEET NO. OF SHEETS		STA. TO STA.		

**TOLLWAY PAVEMENT MARKING PLANS
NOT INCLUDED IN THIS SUBMITTAL**

		USER NAME = .USERNAME.	DESIGNED -	REVISED -	STATE OF ILLINOIS DEPARTMENT OF TRANSPORTATION	LIGHTING PLAN OVERHEAD SIGN STRUCTURE	F.A.I. RTE.	SECTION	COUNTY	TOTAL SHEETS	SHEET NO.
		PLOT SCALE = 50.0000' / IN.	DRAWN - JPW	REVISED -			90	(X2-1)R	WINNEBAGO	510	252
		PLOT DATE = 10/19/2011	CHECKED -	REVISED -	SCALE: SHEET NO. OF SHEETS STA. TO STA.		[ILLINOIS] FED. AID PROJECT				
		DATE - 10/14/11	REVISIED -	REVISED -	CONTRACT NO. 64C29						

Rockton Rd

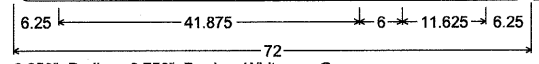

2.250" Radius, 0.750" Border, White on Green;
[Rockton Rd] D;

Table of widths and spaces.

6.250	R	5.375	1.750	o	4.625	1.500	c	4.500	2.125	k	4.500	1.250	t	3.500	1.500	o	4.750	2.000	n	4.500
	R	5.375	1.750	d	4.500	6.250														

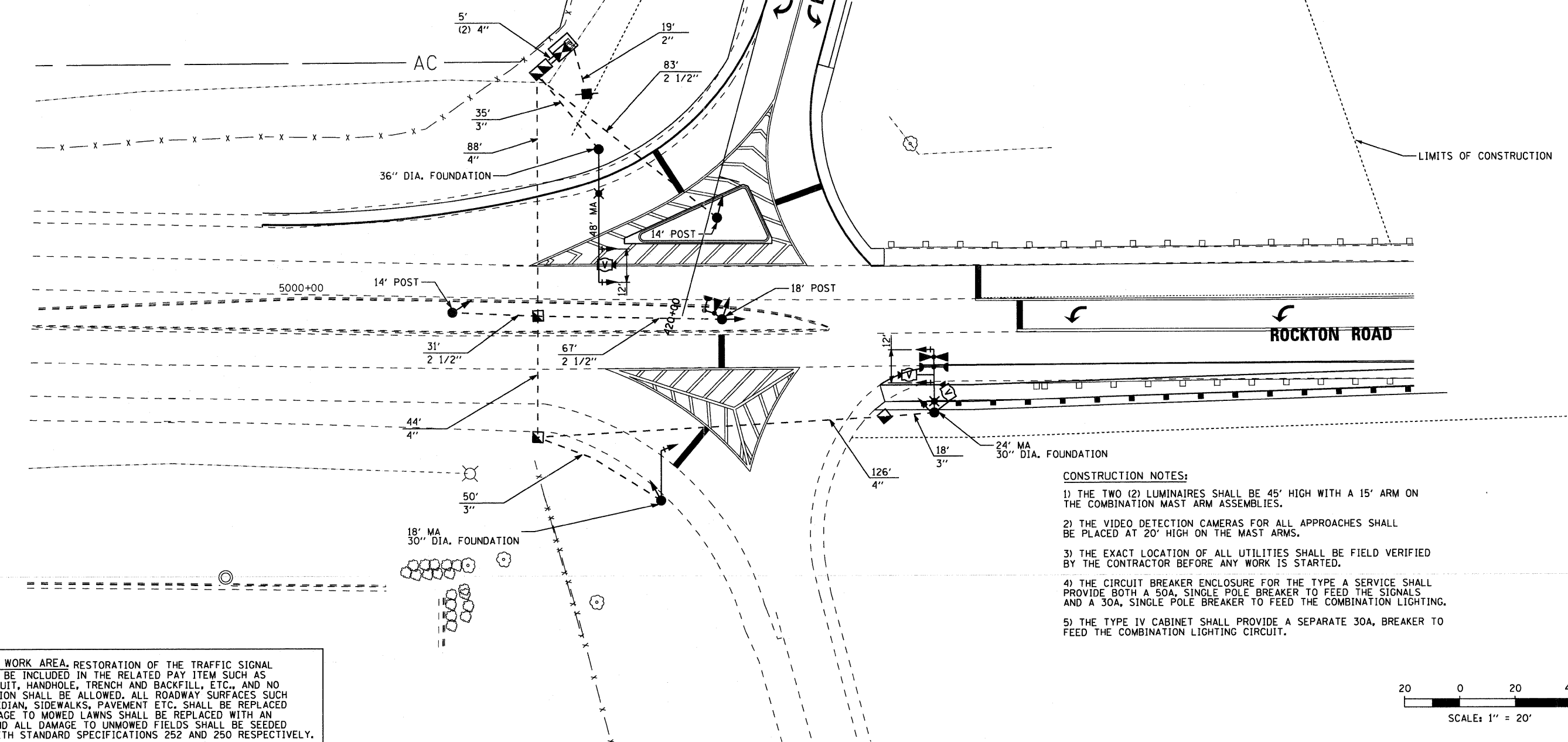

- CONSTRUCTION NOTES:**
- 1) THE TWO (2) LUMINAIRES SHALL BE 45' HIGH WITH A 15' ARM ON THE COMBINATION MAST ARM ASSEMBLIES.
 - 2) THE VIDEO DETECTION CAMERAS FOR ALL APPROACHES SHALL BE PLACED AT 20' HIGH ON THE MAST ARMS.
 - 3) THE EXACT LOCATION OF ALL UTILITIES SHALL BE FIELD VERIFIED BY THE CONTRACTOR BEFORE ANY WORK IS STARTED.
 - 4) THE CIRCUIT BREAKER ENCLOSURE FOR THE TYPE A SERVICE SHALL PROVIDE BOTH A 50A, SINGLE POLE BREAKER TO FEED THE SIGNALS AND A 30A, SINGLE POLE BREAKER TO FEED THE COMBINATION LIGHTING.
 - 5) THE TYPE IV CABINET SHALL PROVIDE A SEPARATE 30A, BREAKER TO FEED THE COMBINATION LIGHTING CIRCUIT.

RESTORATION OF WORK AREA: RESTORATION OF THE TRAFFIC SIGNAL WORK AREA SHALL BE INCLUDED IN THE RELATED PAY ITEM SUCH AS FOUNDATION, CONDUIT, HANDHOLE, TRENCH AND BACKFILL, ETC., AND NO EXTRA COMPENSATION SHALL BE ALLOWED. ALL ROADWAY SURFACES SUCH AS SHOULDERS, MEDIAN, SIDEWALKS, PAVEMENT ETC. SHALL BE REPLACED IN KIND. ALL DAMAGE TO MOWED LAWNS SHALL BE REPLACED WITH AN APPROVED SOD, AND ALL DAMAGE TO UNMOWED FIELDS SHALL BE SEEDING IN ACCORDANCE WITH STANDARD SPECIFICATIONS 252 AND 250 RESPECTIVELY.

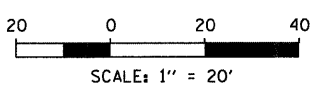

- CONTROLLER CABINET
 - UNINTERRUPTIBLE POWER SUPPLY
 - SERVICE INSTALLATION,
(P) POLE OR (G) GROUND MOUNT
 - STEEL MAST ARM ASSEMBLY AND POLE
 - STEEL COMBINATION MAST ARM
ASSEMBLY AND POLE WITH LUMINAIRE
 - SIGNAL POST
 - SIGNAL HEAD
 - SIGNAL HEAD WITH BACKPLATE
 - VIDEO DETECTION CAMERA
 - EMERGENCY VEHICLE LIGHT DETECTOR
 - CONFIRMATION BEACON
 - HANDHOLE
 - HEAVY DUTY HANDHOLE
 - DOUBLE HANDHOLE
 - GALVANIZED STEEL CONDUIT
IN TRENCH (T) OR PUSHED (P)
-
- SIGNAL FACE
 - SIGNAL FACE WITH BACKPLATE.
"P" INDICATES PROGRAMMED HEAD
-
- DENOTES NUMBER OF CONDUCTORS, ELECTRIC
CABLE NO. 14, UNLESS NOTED OTHERWISE,
ALL DETECTOR LOOP CABLE TO BE SHIELDED
 - GROUND CABLE IN CONDUIT
NO. 6 SOLID COPPER (GREEN)
 - VENDOR CABLE FOR CAMERA
 - GROUND ROD AT (C) CONTROLLER,
(H) HANDHOLE, (P) POST, (M) MAST ARM,
OR (S) SERVICE
 - LUMINAIRE, 250 WATT

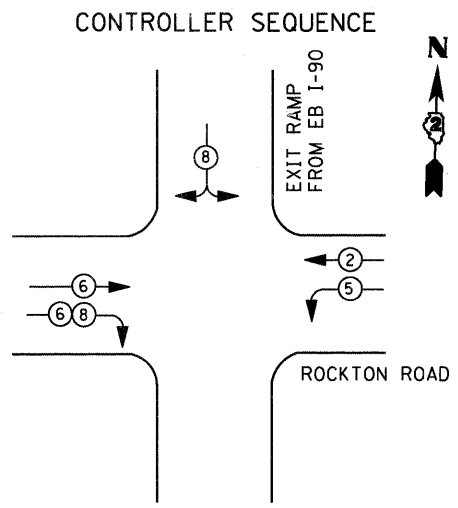

PHASE DESIGNATION DIAGRAM
REFER TO STANDARD 857001

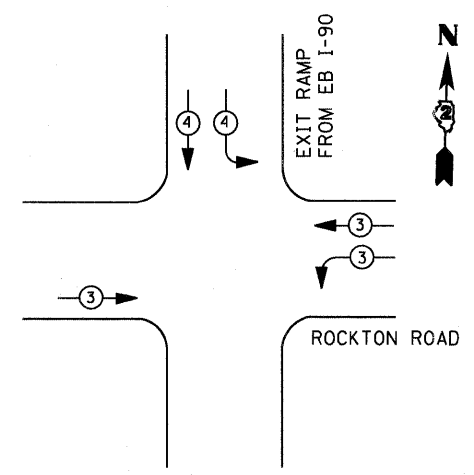

EMERGENCY VEHICLE PREEMPTION SEQUENCE

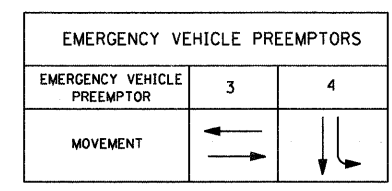

- ### LEGEND
- DUAL ENTRY PHASE
 - PEDESTRIAN PHASE
 - SINGLE ENTRY PHASE
 - OVERLAP
 - * NUMBER REFERS TO ASSOCIATED PHASE

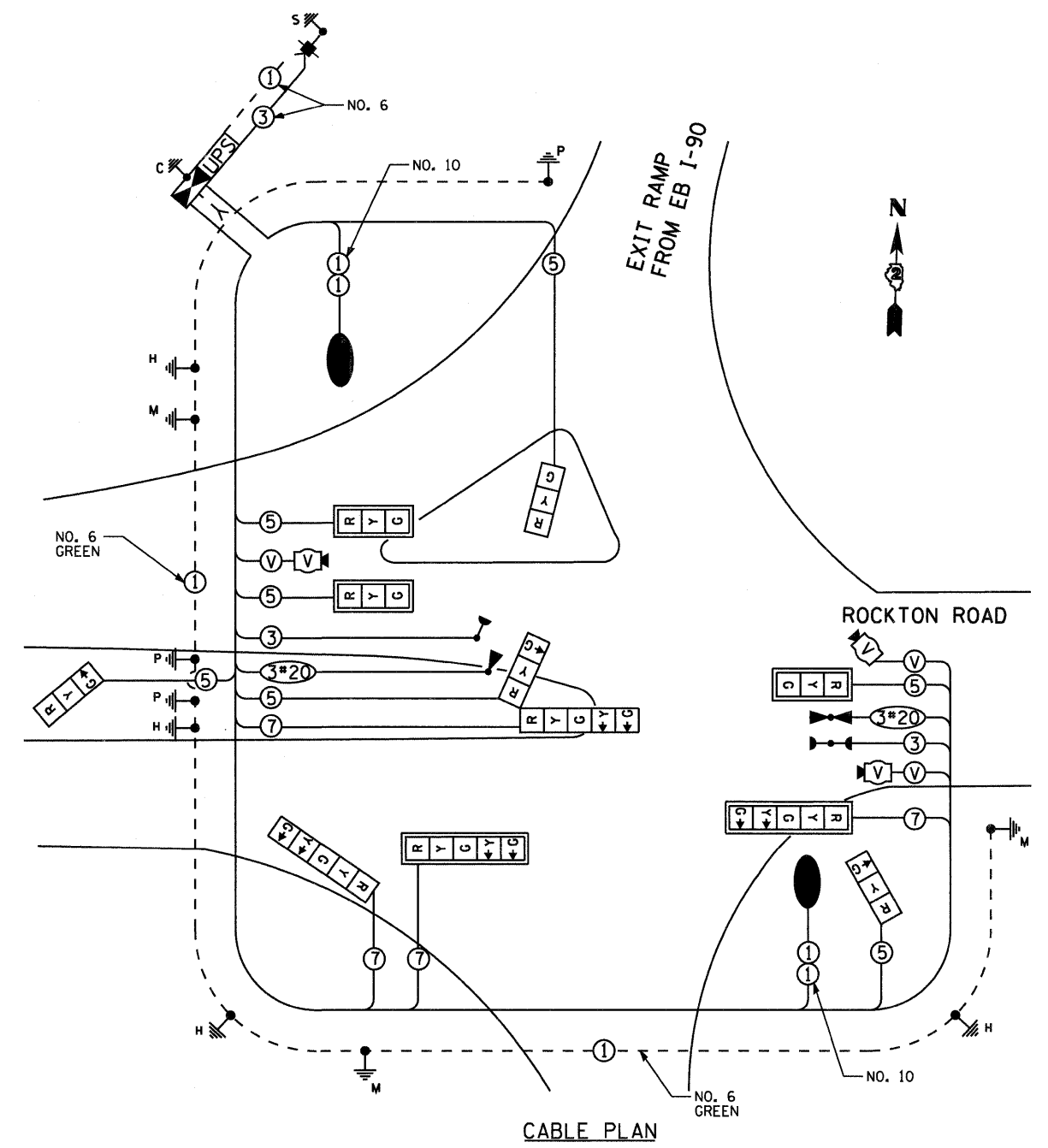

I. D. O. T. TRAFFIC SIGNAL INSTALLATION ELECTRICAL SERVICE REQUIREMENTS					
TYPE	NO. LAMPS	WATTAGE		% OPERATIONS	TOTAL WATTAGE
		INCAND.	LED		
SIGNAL (RED)	11	135	17	0.50	93.5
(YELLOW)	11	135	25	0.25	68.75
(GREEN)	11	135	15	0.25	41.25
ARROW	8	135	12	0.10	9.6
PED. SIGNAL		90	25	1.00	--
CONTROLLER	1	100	100	1.00	100
ILLUM. SIGN		252	25	0.05	--
VIDEO SYSTEM	1	150	150	1.00	150
LUMINAIRE	2	250		1.00	500
FLASHER LED					TOTAL = 958.3
ENERGY COSTS- BILLED TO: WINNEBAGO COUNTY HIGHWAY DEPARTMENT 424 NORTH SPRINGFIELD AVE. ROCKFORD, IL 61101					
ENERGY SUPPLY - CONTACT ROD MAGNUSON PHONE 866-752-4550 COMPANY ROCK ENERGY COOPERATIVE					

RESTORATION OF WORK AREA. RESTORATION OF THE TRAFFIC SIGNAL WORK AREA SHALL BE INCLUDED IN THE RELATED PAY ITEM SUCH AS FOUNDATION, CONDUIT, HANDHOLE, TRENCH AND BACKFILL, ETC., AND NO EXTRA COMPENSATION SHALL BE ALLOWED. ALL ROADWAY SURFACES SUCH AS SHOULDERS, MEDIAN, SIDEWALKS, PAVEMENT ETC. SHALL BE REPLACED IN KIND. ALL DAMAGE TO MOWED LAWNS SHALL BE REPLACED WITH AN APPROVED SOD, AND ALL DAMAGE TO UNMOWED FIELDS SHALL BE SEEDED IN ACCORDANCE WITH STANDARD SPECIFICATIONS 252 AND 250 RESPECTIVELY.



LIMITS OF CONSTRUCTION

ENTRANCE RAMP TO WB I-90

LIMITS OF CONSTRUCTION

Rockton Rd

6.25 41.875 6 11.625 6.25
72

2.250" Radius, 0.750" Border, White on Green;

[Rockton Rd] D;

Table of widths and spaces.

	R	o	c	k	t	o	n
6.250	5.375	1.750	4.625	1.500	4.500	2.125	4.500
	R	o	c	k	t	o	n
6.000	5.375	1.750	4.500	6.250			

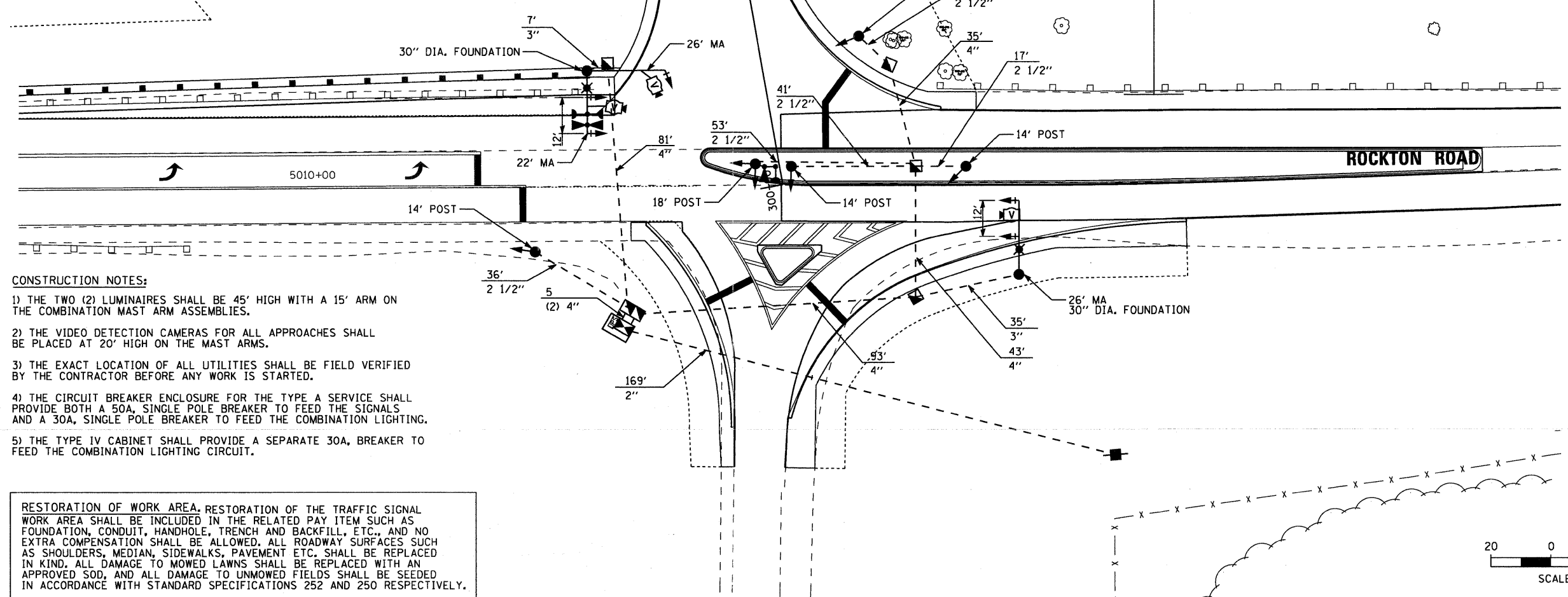

CONSTRUCTION NOTES:

- 1) THE TWO (2) LUMINAIRES SHALL BE 45' HIGH WITH A 15' ARM ON THE COMBINATION MAST ARM ASSEMBLIES.
- 2) THE VIDEO DETECTION CAMERAS FOR ALL APPROACHES SHALL BE PLACED AT 20' HIGH ON THE MAST ARMS.
- 3) THE EXACT LOCATION OF ALL UTILITIES SHALL BE FIELD VERIFIED BY THE CONTRACTOR BEFORE ANY WORK IS STARTED.
- 4) THE CIRCUIT BREAKER ENCLOSURE FOR THE TYPE A SERVICE SHALL PROVIDE BOTH A 50A, SINGLE POLE BREAKER TO FEED THE SIGNALS AND A 30A, SINGLE POLE BREAKER TO FEED THE COMBINATION LIGHTING.
- 5) THE TYPE IV CABINET SHALL PROVIDE A SEPARATE 30A, BREAKER TO FEED THE COMBINATION LIGHTING CIRCUIT.

RESTORATION OF WORK AREA. RESTORATION OF THE TRAFFIC SIGNAL WORK AREA SHALL BE INCLUDED IN THE RELATED PAY ITEM SUCH AS FOUNDATION, CONDUIT, HANDHOLE, TRENCH AND BACKFILL, ETC., AND NO EXTRA COMPENSATION SHALL BE ALLOWED. ALL ROADWAY SURFACES SUCH AS SHOULDERS, MEDIAN, SIDEWALKS, PAVEMENT ETC. SHALL BE REPLACED IN KIND. ALL DAMAGE TO MOWED LAWNS SHALL BE REPLACED WITH AN APPROVED SOD, AND ALL DAMAGE TO UNMOWED FIELDS SHALL BE SEEDING IN ACCORDANCE WITH STANDARD SPECIFICATIONS 252 AND 250 RESPECTIVELY.

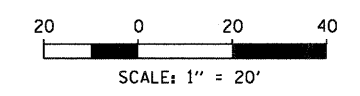

McClure LOCHNER
Engineering Associates, Inc.
RWA
RWA Engineering & Construction, Inc.
O&E
QUIGO ENGINEERING INC.

USER NAME = .USERNAME.	DESIGNED -	REVISED -
PLOT SCALE = 20,0000 ' / IN.	DRAWN - DW	REVISED -
PLOT DATE = 10/19/2011	CHECKED - JDH	REVISED -
	DATE - 10-21-2011	REVISED -

STATE OF ILLINOIS
DEPARTMENT OF TRANSPORTATION

TRAFFIC SIGNAL PLAN
ROCKTON ROAD AND I-90 WESTBOUND RAMP
SCALE: 1"=20'-0" SHEET NO. 3 OF 4 SHEETS STA. TO STA.

F.A.I. RTE. 90	SECTION (X2-1) R	COUNTY WINNEBAGO	TOTAL SHEETS 510	SHEET NO. 255
			CONTRACT NO. 64C29	
[ILLINOIS] FED. AID PROJECT				

- CONTROLLER CABINET
- UNINTERRUPTIBLE POWER SUPPLY
- SERVICE INSTALLATION,
(P) POLE OR (G) GROUND MOUNT
- STEEL MAST ARM ASSEMBLY AND POLE
- STEEL COMBINATION MAST ARM
ASSEMBLY AND POLE WITH LUMINAIRE
- SIGNAL POST
- SIGNAL HEAD
- SIGNAL HEAD WITH BACKPLATE
- VIDEO DETECTION CAMERA
- EMERGENCY VEHICLE LIGHT DETECTOR
- CONFIRMATION BEACON
- HANDHOLE
- HEAVY DUTY HANDHOLE
- DOUBLE HANDHOLE
- GALVANIZED STEEL CONDUIT
IN TRENCH (T) OR PUSHED (P)



- DENOTES NUMBER OF CONDUCTORS, ELECTRIC
CABLE NO. 14, UNLESS NOTED OTHERWISE,
ALL DETECTOR LOOP CABLE TO BE SHIELDED
- GROUND CABLE IN CONDUIT
NO. 6 SOLID COPPER (GREEN)
- VENDOR CABLE FOR CAMERA
- GROUND ROD AT (C) CONTROLLER,
(H) HANDHOLE, (P) POST, (M) MAST ARM,
OR (S) SERVICE
- LUMINAIRE, 250 WATT

CONTROLLER SEQUENCE

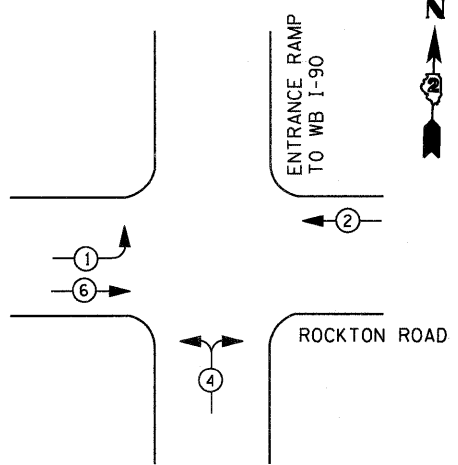

PHASE DESIGNATION DIAGRAM

REFER TO STANDARD 857001

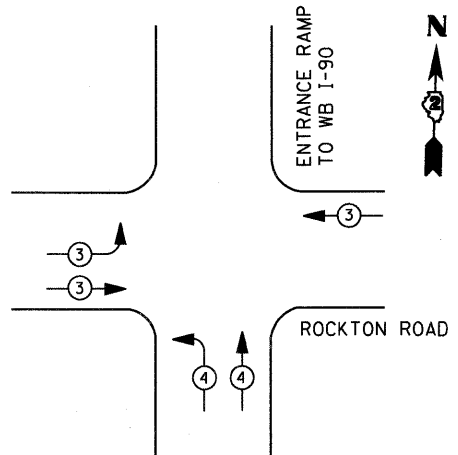

EMERGENCY VEHICLE PREEMPTION SEQUENCE

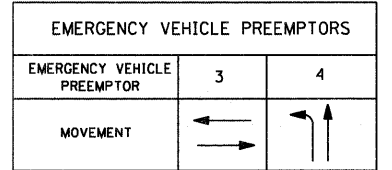

LEGEND

- DUAL ENTRY PHASE
- PEDESTRIAN PHASE
- SINGLE ENTRY PHASE
- OVERLAP
- * NUMBER REFERS TO
ASSOCIATED PHASE

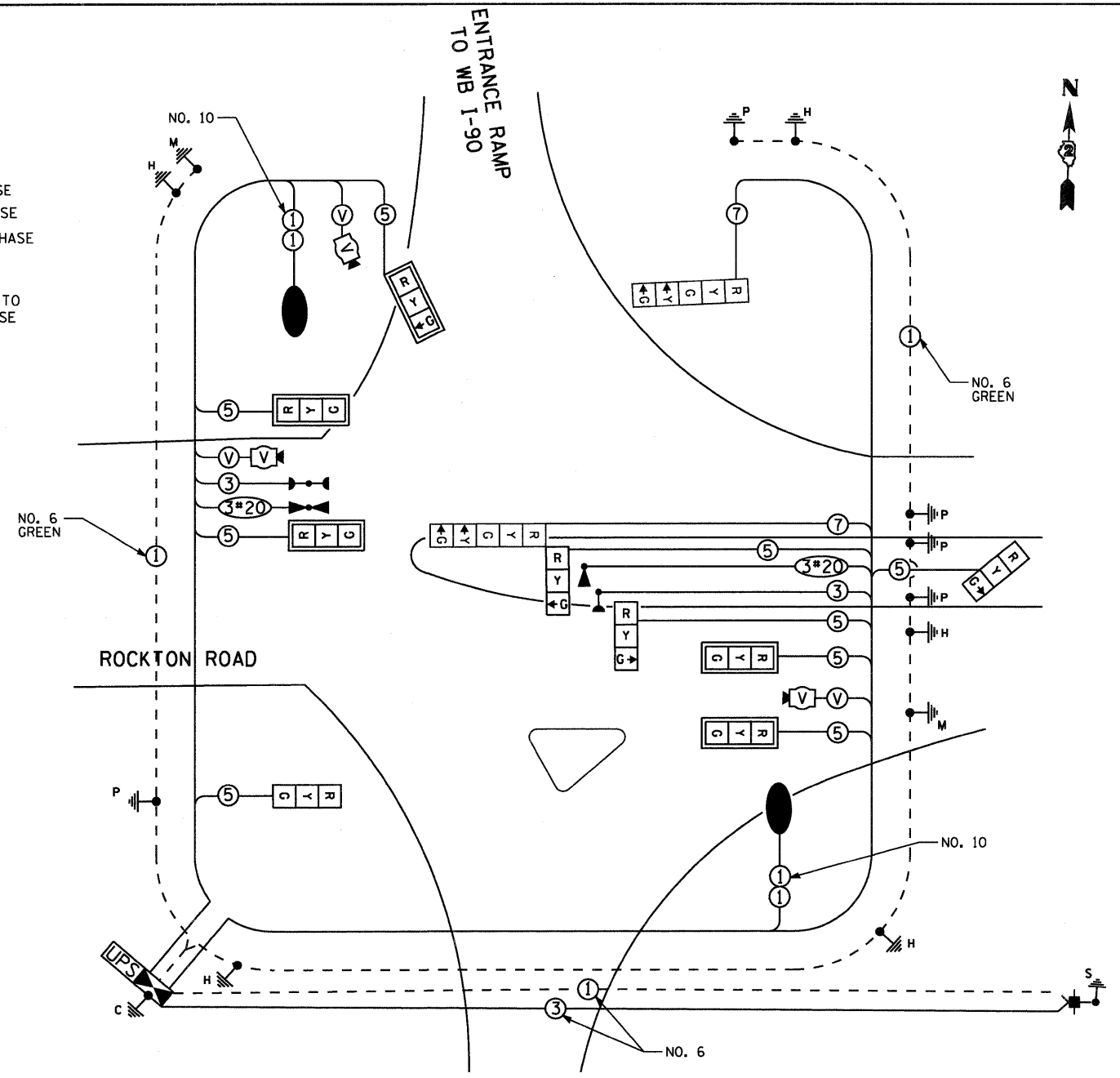

CABLE PLAN

RESTORATION OF WORK AREA, RESTORATION OF THE TRAFFIC SIGNAL WORK AREA SHALL BE INCLUDED IN THE RELATED PAY ITEM SUCH AS FOUNDATION, CONDUIT, HANDHOLE, TRENCH AND BACKFILL, ETC., AND NO EXTRA COMPENSATION SHALL BE ALLOWED. ALL ROADWAY SURFACES SUCH AS SHOULDERS, MEDIAN, SIDEWALKS, PAVEMENT ETC. SHALL BE REPLACED IN KIND. ALL DAMAGE TO MOWED LAWNS SHALL BE REPLACED WITH AN APPROVED SOD, AND ALL DAMAGE TO UNMOWED FIELDS SHALL BE SEEDD IN ACCORDANCE WITH STANDARD SPECIFICATIONS 252 AND 250 RESPECTIVELY.

I. D. O. T. TRAFFIC SIGNAL INSTALLATION ELECTRICAL SERVICE REQUIREMENTS					
TYPE	NO. LAMPS	WATTAGE		% OPERATIONS	TOTAL WATTAGE
		INCAND.	LED		
SIGNAL (RED)	11	135	17	0.50	93.5
(YELLOW)	11	135	25	0.25	68.75
(GREEN)	11	135	15	0.25	41.25
ARROW	4	135	12	0.10	4.8
PED. SIGNAL		90	25	1.00	--
CONTROLLER	1	100	100	1.00	100
ILLUM. SIGN		252	25	0.05	--
VIDEO SYSTEM	1	150	150	1.00	150
LUMINAIRE	2	250		1.00	500
FLASHER LED					TOTAL = 958.3

ENERGY COSTS- BILLED TO: WINNEBAGO COUNTY HIGHWAY DEPARTMENT
424 NORTH SPRINGFIELD AVE.
ROCKFORD, IL 61101

ENERGY SUPPLY - CONTACT ROD MAGNUSON
PHONE 866-752-4550
COMPANY ROCK ENERGY COOPERATIVE

GENERAL NOTES:

- ALL NEW CONDUIT, UNIT DUCTS, DIRECT BURIAL CABLE, AND APPURTENANCES ARE INDICATED DIAGRAMMATICALLY ON THE DRAWINGS. THE ACTUAL LOCATIONS IN THE FIELD ARE TO BE SURVEYED AND STAKED BY THE CONTRACTOR. THESE LOCATIONS SHALL MEET WITH APPROVAL OF THE ENGINEER PRIOR TO INSTALLATION AND CONSTRUCTION.
- THE ELECTRICAL WORK SHALL BE PERFORMED IN ACCORDANCE WITH THE IDOT STANDARD SPECIFICATIONS FOR ROAD AND BRIDGE CONSTRUCTION AND ASSOCIATED SUPPLEMENTAL SPECIFICATIONS. ELECTRICAL WORK IN THE AREA UNDER TOLLWAY JURISDICTION SHALL BE ALSO BE IN ACCORDANCE WITH THE TOLLWAY SUPPLEMENTAL SPECIFICATIONS (TOLLWAY SUPPLEMENTAL SPECIFICATIONS GOVERN OVER IDOT STANDARD AND SUPPLEMENTAL SPECIFICATIONS).
- THE CONTRACTOR SHALL FURNISH AND INSTALL LUMINAIRE LAMPS IN ACCORDANCE WITH THE SUPPLIER'S RECOMMENDATIONS AND IN ACCORDANCE WITH THE SPECIFICATIONS. ALL LUMINAIRES SHALL BE ORIENTED WITH THE OPTICS PERPENDICULAR TO THE ROADWAY UNLESS OTHERWISE INDICATED OR DIRECTED BY THE ENGINEER. THE COST OF THIS WORK AND MATERIAL SHALL BE INCLUDED IN THE APPLICABLE LUMINAIRE PAY ITEM.
- CONDUITS AND UNIT DUCTS SHALL BE INSTALLED AT A MINIMUM 30 INCHES DEPTH BELOW GRADE AND POSITIONED IN THE FIELD TO AVOID CONFLICT WITH ROADWAY UNDER DRAINS AND OTHER EXISTING AND PROPOSED UTILITIES. THE CONTRACTOR SHALL INCREASE DEPTH OF UNIT DUCT AND CONDUIT AS REQUIRED AT NO ADDITIONAL COST. THE CONTRACTOR SHALL COORDINATE RACEWAY DEPTH WITH THE ELECTRICAL DETAILS AND THE ENGINEER.
- WHERE THE CONTRACTOR'S EXCAVATION MEETS AN OBSTRUCTION, THE CONTRACTOR SHALL NOTIFY THE ENGINEER FOR DIRECTION IN WRITING PRIOR TO EXCAVATION. THE CONTRACTOR SHALL RESTORE ANY DAMAGE TO EXISTING SYSTEMS OR UTILITIES AND REMOVE EXISTING OBSTRUCTIONS AND FOUNDATIONS TO THE SATISFACTION OF THE ENGINEER. THIS WORK SHALL BE PAID ACCORDING TO 109.04(B) OF THE IDOT STANDARD SPECIFICATIONS FOR ROAD AND BRIDGE CONSTRUCTION, LATEST EDITION.
- WHEREVER THE TEMPORARY AERIAL CABLE IS REQUIRED TO CROSS AN EXISTING AND/OR PROPOSED ROADWAY, THE CONTRACTOR SHALL MAINTAIN A MINIMUM OF 20 FEET OF VERTICAL CLEARANCE OVER THE ROADWAY AT ALL TIMES.

HIGHWAY STANDARD

805001-01	ELECTRIC SERVICE INSTALLATION DETAILS
814001-02	HANDHOLES
825011-02	LIGHTING CONTROLLER PEDESTAL MOUNTED, 240V
830021	LIGHT POLE STEEL TENON TOP
836001-01	LIGHT POLE FOUNDATION

TEMPORARY LIGHTING NOTES:

ROCKTON RD GENERAL NOTES:

- ONLY THE POLES IDENTIFIED TO BE ACTIVE IN EACH STAGE SHALL BE CONNECTED TO THE CONTROLLER DURING THAT STAGE.
- CONTRACTOR TO LOCATE ALL EXISTING CONDUITS PRIOR TO INSTALLING TEMPORARY LIGHTING.
- CONTRACTOR TO VERIFY CIRCUITRY OF EXISTING LIGHTING PRIOR TO ALTERING THE EXISTING CONTROLLER OR INSTALLATION OF TEMPORARY LIGHTING.

ROCKTON ROAD ENTRANCE RAMP:

STAGE 1A:

- TEMPORARY RAMP BEING CONSTRUCTED DURING PHASE.
- TRAFFIC ON EXISTING RAMP ALIGNMENT AND EXISTING LIGHTING TO REMAIN IN PLACE.
- INSTALL TEMPORARY LIGHTING TO BE CONNECTED TO NEW 60A,120/240V, SINGLE PHASE CONTROLLER ADJACENT TO EXISTING CONTROLLER.
- INSTALL PROPOSED UNIT DUCT AND CONDUIT FROM THE CONTROLLER TO HANDHOLE (FOR CROSSING UNDER I-90) AT EAST SIDE OF ENTRANCE RAMP.
- CONNECT TEMPORARY LIGHTING TO HANDHOLE (FOR CROSSING UNDER I-90) AND GO AERIALY TO PROPOSED TEMPORARY LIGHT POLES.
- TEMPORARY LIGHTING TO BE READY, BUT NOT ACTIVATED, PRIOR TO BEGINNING OF STAGE 1B.

STAGE 1B:

- WHEN THE TRAFFIC IS MOVED TO THE TEMPORARY RAMP, TURN OFF THE EXISTING LIGHTS FOR THE ENTRANCE RAMP AND ACTIVATE THE TEMPORARY LIGHTING.
- PROPOSED LIGHTING TO BE INSTALLED DURING THIS STAGE AND OPERATIONAL, BUT NOT ACTIVATED, PRIOR TO BEGINNING STAGE 2A.

STAGE 2A:

- WHEN TRAFFIC IS MOVED TO PROPOSED RAMP, ACTIVATE THE PROPOSED LIGHTING AND REMOVE THE TEMPORARY LIGHTING.

ROCKTON ROAD EXIT RAMP:

STAGE 1A:

- TRAFFIC IS ON EXISTING RAMP ALIGNMENT AND EXISTING LIGHTING TO REMAIN IN PLACE.
- INSTALL TEMPORARY LIGHTING TO BE CONNECTED TO NEW 60A,120/240V, SINGLE PHASE CONTROLLER ADJACENT TO EXISTING CONTROLLER.
- INSTALL PROPOSED UNIT DUCT AND CONDUIT FROM THE CONTROLLER TO HANDHOLE (FOR CROSSING UNDER I-90) AT WEST SIDE OF EXIT RAMP.
- CONNECT TEMPORARY LIGHTING TO HANDHOLE (FOR CROSSING UNDER I-90) AND GO AERIALY TO PROPOSED TEMPORARY LIGHT POLES.
- TEMPORARY LIGHTING TO BE READY, BUT NOT ACTIVATED, PRIOR TO BEGINNING OF STAGE 1B.

TEMPORARY LIGHTING NOTES (CONT.):

STAGE 1B:

- TRAFFIC IS ON EXISTING RAMP ALIGNMENT.
- WHEN TEMPORARY LIGHTING IS ACTIVATED FOR ROCKTON ROAD ENTRANCE RAMP, ACTIVATE THE TEMPORARY LIGHTING FOR ROCKTON ROAD EXIT RAMP SO THAT EXISTING CONTROLLER CAN BE REMOVED FROM SERVICE.
- TEMPORARY RAMP IS TO BE CONSTRUCTED DURING THIS STAGE.

STAGE 2A & 2B:

- TRAFFIC IS TO BE MOVED TO TEMPORARY RAMP.
- TEMPORARY LIGHTING TO REMAIN IN PLACE THROUGHOUT STAGES.
- PROPOSED LIGHTING IS BEING INSTALLED DURING THESE STAGES AND READY FOR ACTIVATION PRIOR TO STAGE 3.

STAGE 3:

- WHEN TRAFFIC IS MOVED TO PROPOSED ALIGNMENT OF RAMP, ACTIVATE THE PROPOSED LIGHTING AND REMOVE THE TEMPORARY LIGHTING

RAMP "C":

GENERAL NOTES:

- ONLY THE POLES IDENTIFIED TO BE ACTIVE IN EACH STAGE SHALL BE CONNECTED TO THEIR RESPECTIVE CONTROLLER DURING THAT STAGE.
- CONTRACTOR TO LOCATE ALL EXISTING CONDUITS PRIOR TO INSTALLING TEMPORARY LIGHTING.
- CONTRACTOR TO VERIFY CIRCUITRY OF EXISTING LIGHTING PRIOR TO ALTERING THE EXISTING CONTROLLER OR INSTALLATION OF TEMPORARY LIGHTING.
- VISITOR CENTER IS TO BE CLOSED DURING CONSTRUCTION.

STAGE 1A:

- TRAFFIC IS ON EXISTING RAMP ALIGNMENT UNTIL TEMPORARY LIGHTING IS INSTALLED NEAR VISITOR CENTER FOR THIS STAGE.
- THE EXISTING LIGHTING TO REMAIN IN PLACE AND OPERATIONAL AT RAMP C.
- TIE TEMPORARY LIGHTING NEAR VISITOR CENTER INTO VISITOR CENTER EXISTING LIGHTING CIRCUIT FOR POLES 1 THROUGH 5.
- EXISTING POLES 1 THROUGH 5 OF THE VISITOR CENTER LIGHTING SHALL BE DISCONNECTED PRIOR TO ACTIVATING THE TEMPORARY LIGHTING.
- INSTALL TEMPORARY LIGHTING FOR STAGE 1B.
- RAMP C TEMPORARY LIGHTING TO BE CONNECTED TO EXISTING CIRCUIT. DO NOT CONNECT TEMPORARY LIGHTING TO CONTROLLER #2 UNTIL POLES 24 THROUGH 26 OF RAMP C HAVE BEEN DISCONNECTED FROM THE CONTROLLER.
- TEMPORARY LIGHTING TO BE IN PLACE AND READY FOR ACTIVATION PRIOR TO BEGINNING OF STAGE 1B.
- VISITOR CENTER LIGHT POLES 1 THROUGH 3 ARE TO BE RELOCATED DURING STAGES 1A AND 1B.

STAGE 1B:

- WHEN THE TRAFFIC IS MOVED TO THE TEMPORARY RAMP, DISCONNECT EXISTING LIGHT POLES NOS. 24 THROUGH 26 AND ACTIVATE THE TEMPORARY LIGHTING.
- POLES NOS. 24 AND 25 ARE TO BE RELOCATED AND INSTALLED DURING THIS STAGE AND READY FOR ACTIVATION, BUT NOT ACTIVATED, PRIOR TO BEGINNING STAGE 2A.
- REMOVE TEMPORARY LIGHTING NEAR THE VISITOR CENTER.

STAGE 2A:

- WHEN TRAFFIC IS MOVED TO PROPOSED RAMP, DISCONNECT THE STAGE 1B RAMP C TEMPORARY LIGHTING AND RECONNECT LIGHT POLE NOS. 24 THROUGH 26.
- REMOVE THE RAMP C TEMPORARY LIGHTING.

RAMP "B":

STAGES 1A & 1B:

- TRAFFIC IS ON EXISTING RAMP ALIGNMENT AND EXISTING LIGHTING TO REMAIN IN PLACE UNTIL TEMPORARY LIGHTING CAN BE INSTALLED DURING STAGE 2A.
- TEMPORARY LIGHTING TO BE INSTALLED BUT NOT ACTIVATED IN STAGE 1.

STAGE 2A

- TEMPORARY LIGHTING TO BE CONNECTED TO EXISTING CIRCUIT IN STAGE 2A.
- EXISTING POLES 18, 19, 20 AND 23 OF RAMP B ARE TO BE DISCONNECTED FROM THE CONTROLLER IN THIS STAGE AND TEMPORARY POLES TB-1 THROUGH 5 ARE TO BE CONNECTED TO THE CONTROLLER AFTER THE IDENTIFIED EXISTING POLES HAVE BEEN DISCONNECTED FROM THE CONTROLLER.
- WHEN TRAFFIC IS MOVED TO INSIDE ALIGNMENT, THE TEMPORARY LIGHTING SHALL BE ACTIVATED.
- PROPOSED LIGHTING IS BEING INSTALLED DURING STAGES 2A AND 2B, READY FOR ACTIVATION PRIOR TO STAGE 3.

STAGE 2B

- TEMPORARY LIGHTING FOR THIS STAGE CONSISTS OF EXISTING POLES 16, 17, 21, 22 AND 23 AND TEMPORARY LIGHT POLES TB-1 THROUGH TB-3, TB-6 AND TB-7.
- TEMPORARY LIGHT POLES TB-4 AND TB-5 WILL BE DISCONNECTED FROM THE CONTROLLER PRIOR TO ACTIVATING THE STAGE 2B TEMPORARY LIGHTING.
- REMOVE TEMPORARY LIGHT POLES TB-4 AND TB-5.

STAGE 3:

- WHEN TRAFFIC IS MOVED TO PROPOSED ALIGNMENT OF RAMP, DISCONNECT THE STAGE 2B TEMPORARY LIGHTING FROM THE CONTROLLER AND ACTIVATE THE PROPOSED LIGHTING.
- REMOVE THE TEMPORARY LIGHTING.

LEGEND

- UNIT DUCT, 600V, 2-1C NO.6, 1/C NO.6 GROUND, (XLP-TYPE USE), 1" DIA. POLYETHYLENE
- UNIT DUCT, 600V, 2-1C NO.2, 1/C NO.2 GROUND, (XLP-TYPE USE), 1 1/4" DIA. POLYETHYLENE
- UNIT DUCT, 600V, 4-1C NO.2, 1/C NO.4 GROUND, (XLP-TYPE USE), 1 1/2" DIA. POLYETHYLENE
- AERIAL CABLE, 2-1/C NO.2 WITH MESSENGER WIRE
- AERIAL CABLE, 4-1/C NO.2/0 WITH MESSENGER WIRE
- AERIAL CABLE, 4-1/C NO.2 WITH MESSENGER WIRE
- AERIAL CABLE, 2-1/C NO.6 WITH MESSENGER WIRE
- UNIT DUCT, WITH 4-1/C NO.2 AND 1/C NO.8 GROUND, 600V (XLP-TYPE USE) 2" DIA. CNC
- AERIAL CABLE, 2-1/C NO.2/0 WITH MESSENGER WIRE
- UNIT DUCT, 600V, 2-1C NO.4, 1/C NO.4 GROUND, (XLP-TYPE USE), 1" DIA. POLYETHYLENE
- UNIT DUCT, 600V 2-1C NO.8, 1C NO.8 GROUND, (XLP-TYPE USE) 2" DIA. CNC
- EXISTING LIGHT POLE TO REMAIN (UNLESS NOTED OTHERWISE)
- EXISTING LIGHTING CONTROLLER
- PROPOSED LIGHTING CONTROLLER
- TEMPORARY WOOD POLE, 40 FT, CLASS 4 (UNLESS NOTED OTHERWISE)
- PROPOSED HAND HOLE
- PROPOSED TEMPORARY LIGHT POLE, WOOD, 45 FT MH WITH (1) 250W HPS VAPOR MM FIXTURE (UNLESS NOTED OTHERWISE)
- PROPOSED TEMPORARY BREAKAWAY POLE 45 FT M.H. TENON MOUNT WITH 250W HPS MM FIXTURE (UNLESS NOTED OTHERWISE)
- PROPOSED LIGHT POLE, WEATHERING STEEL, 45 FT. M.H., TENON MOUNT WITH (1) 250W HPS VAPOR MM FIXTURE
- PROPOSED LIGHT POLE, WEATHERING STEEL, 45 FT. M.H., TENON MOUNT WITH (1) 400W HPS VAPOR MM FIXTURE
- PROPOSED LIGHT POLE, WEATHERING STEEL, 45 FT. M.H., (1) 250W HPS VAPOR MM FIXTURE WITH 15 FT MAST ARM
- PROPOSED TEMPORARY LIGHT POLE, WOOD, 45 FT MH, WITH (1) 400W HPS VAPOR FIXTURE, 8 FEET MAST ARM

SCHEDULE OF QUANTITIES

PAY ITEM	DESCRIPTION	UNIT	TOTAL
80300100	LOCATING UNDERGROUND CABLE	FOOT	4,755
81028390	UNDERGROUND CONDUIT, PVC, 4" DIA.	FOOT	295
81200270	CONDUIT EMBEDDED IN STRUCTURE, 4" DIA., PVC	FOOT	374
81400100	HANDHOLE	EACH	2
81603025	UNIT DUCT, 600V, 2-1C NO.4, 1/C NO.4 GROUND, (XLP-TYPE USE), 1" DIA. POLYETHYLENE	FOOT	1,259
81603035	UNIT DUCT, 600V, 2-1C NO.6, 1/C NO.6 GROUND, (XLP-TYPE USE), 1" DIA. POLYETHYLENE	FOOT	2,576
81603065	UNIT DUCT, 600V, 2-1C NO.2, 1/C NO.2 GROUND, (XLP-TYPE USE), 1 1/4" DIA. POLYETHYLENE	FOOT	2,315
81603095	UNIT DUCT, 600V, 4-1C NO.2, 1/C NO.4 GROUND, (XLP-TYPE USE), 1 1/2" DIA. POLYETHYLENE	FOOT	904
81800190	AERIAL CABLE, 2-1/C NO. 2 WITH MESSENGER WIRE	FOOT	265
81800400	AERIAL CABLE, 4-1/C NO. 2 WITH MESSENGER WIRE	FOOT	385
82102250	LUMINAIRE, SODIUM VAPOR, HORIZONTAL MOUNT, 250 WATT	EACH	2
82103900	LUMINAIRE, SODIUM VAPOR, MULTI-MOUNT, 250 WATT	EACH	24
82104000	LUMINAIRE, SODIUM VAPOR, MULTI-MOUNT, 400 WATT	EACH	4
82500330	LIGHTING CONTROLLER, PEDESTAL MOUNTED, 240VOLT, 60AMP	EACH	1
83062540	LIGHT POLE, WEATHERING STEEL, 45 FT. M.H., 15 FT. MAST ARM	EACH	2
83062730	LIGHT POLE, WEATHERING STEEL, 45 FT. M.H., TENON MOUNT	EACH	28
83600300	LIGHT POLE FOUNDATION, 30" DIAMETER	FOOT	210
83800650	BREAKAWAY DEVICE, COUPLING WITH STAINLESS STEEL SCREEN	EACH	120
84100110	REMOVAL OF TEMPORARY LIGHTING UNIT	EACH	61
84200500	REMOVAL OF LIGHTING UNIT, SALVAGE	EACH	20
84200804	REMOVAL OF POLE FOUNDATION	EACH	20
84400105	RELOCATE EXISTING LIGHTING UNIT	EACH	1
84500110	REMOVAL OF LIGHTING CONTROLLER	EACH	1
X8950130	MODIFY EXISTING LIGHTING CONTROLLER	EACH	1
*2000241	TEMPORARY LIGHTING SYSTEM, LOCATION 1	L SUM	1
*2000242	TEMPORARY LIGHTING SYSTEM, LOCATION 2	L SUM	1
*2000243	TEMPORARY LIGHTING SYSTEM, LOCATION 3	L SUM	1
*2000244	TEMPORARY LIGHTING SYSTEM, LOCATION 4	L SUM	1
*2000245	TEMPORARY LIGHTING SYSTEM, LOCATION 5	L SUM	1
JS814001	HANDHOLE, TOLLWAY	EACH	1
JS816034	UNIT DUCT, WITH 2-1/C NO. 8 AND 1/C NO. 8 GROUND, 600V (XLP-TYPE USE), 2" DIA. CNC	FOOT	762
JS816035	UNIT DUCT, WITH 4-1/C NO. 2 AND 1C NO. 8 GROUND, 600V (XLP-TYPE USE), 2" DIA. CNC	FOOT	387
JS819001	TRENCH AND BACKFILL FOR ELECTRICAL WORK	FOOT	1,020
JS821003	TEMPORARY LUMINAIRE, SODIUM VAPOR, HORIZONTAL MOUNT, 400 WATT	EACH	4
JS823001	SIGN STRUCTURE WIRING, OVERHEAD SIGN	EACH	2
JS823003	SIGN STRUCTURE WIRING, BRIDGE MOUNTED SIGN	EACH	1
JS830027	TEMPORARY WOOD POLE, 50 FT., CLASS 4	EACH	7
JS842080	REMOVAL OF EXISTING LIGHTING UNIT, SALVAGE	EACH	3
JS842105	POLE FOUNDATION, REMOVED	EACH	2
JS846001	MAINTAIN LIGHTING SYSTEM	L SUM	1
JT821015	REMOVE AND REINSTALL SIGN LUMINAIRE	EACH	15



USER NAME = _USERNAME	DESIGNED - BLM	REVISED -
	DRAWN - JPW	REVISED -
PLOT SCALE = 5/8"=1'-0"	CHECKED - BLM	REVISED -
PLOT DATE = 10/25/2011	DATE - 10/14/11	REVISED -

**STATE OF ILLINOIS
DEPARTMENT OF TRANSPORTATION**

**LIGHTING
GENERAL NOTES AND LEGEND**

SCALE:	SHEET NO. OF SHEETS	STA. TO STA.	F.A.I. RTE. 90	SECTION (X2-1JR)	COUNTY WINNEBAGO	TOTAL SHEETS 510	SHEET NO. 257
						CONTRACT NO. 64C29	
ILLINOIS FED. AID PROJECT							

EAST SIDE
CONTROLLER 2
CKT. 7 (TEMPORARY LIGHTING)

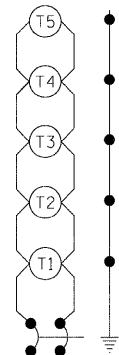

20A, 2 POLE
240V

EAST SIDE
CONTROLLER 2
CKT. 8 (TEMPORARY LIGHTING)

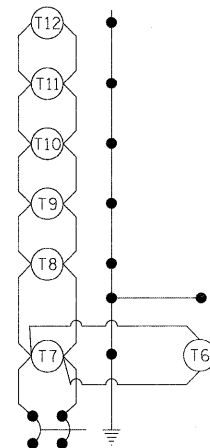

20A, 2 POLE
240V

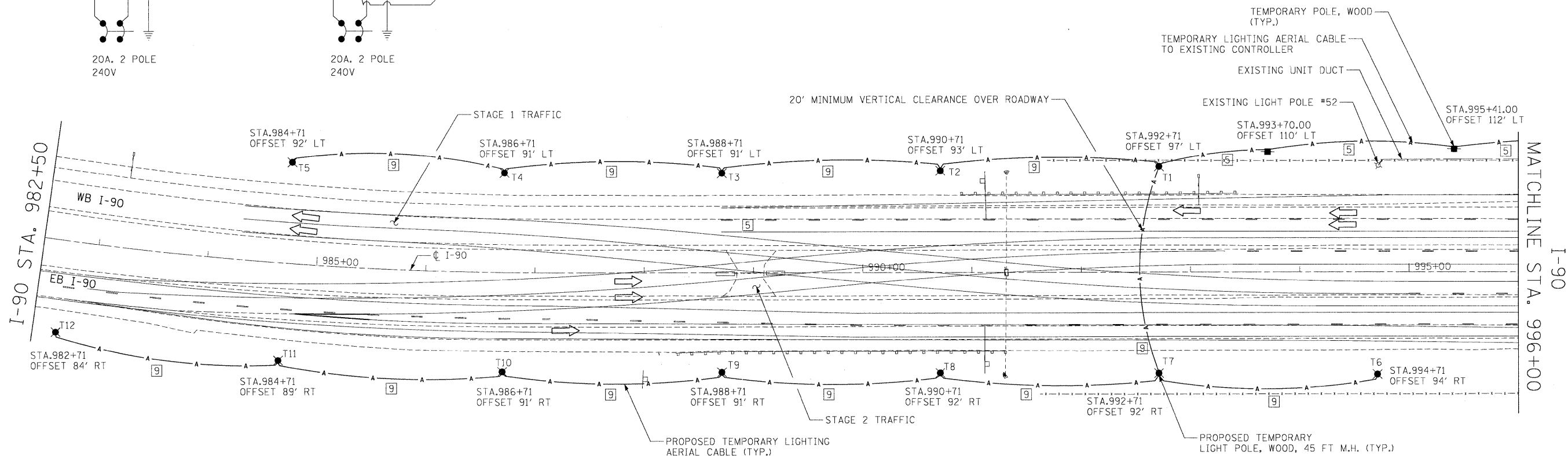

LEGEND:

- EXISTING UNIT DUCT
- ▲— PROPOSED TEMPORARY LIGHTING AERIAL CABLE
- ⊗ EXISTING LIGHT POLE TO REMAIN UNLESS NOTED OTHERWISE
- ⊗ PROPOSED TEMPORARY LIGHT POLE, WOOD, 45 FT. M.H. TENON MOUNT WITH (1) 250W HPS VAPOR FIXTURE
- PROPOSED TEMPORARY WOOD POLE, 40 FT., CLASS 4 (UNLESS NOTED OTHERWISE)
- ⑤ AERIAL CABLE, 4-1/C NO. 2/0 WITH MESSENGER WIRE
- ⑨ AERIAL CABLE, 2-1/C NO. 2/0 WITH MESSENGER WIRE

NOTES:

1. CONTRACTOR MUST LOCATE EXISTING UNIT DUCT BEFORE INSTALLING TEMPORARY WOOD POLES AND TEMPORARY LIGHT POLES.
2. ALL PROPOSED TEMPORARY LIGHT POLES TO BE 45 FT MOUNTING HEIGHT UNLESS OTHERWISE NOTED.
3. CONTRACTOR MUST PROVIDE APPROPRIATE LENGTH OF TEMPORARY WOOD POLE TO MAINTAIN MINIMUM 20' VERTICAL CLEARANCE OVER ROADWAYS.

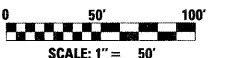

USER NAME = .USERNAME.	DESIGNED - BLM	REVISED -
PLOT SCALE = 50.0000' / IN.	DRAWN - JPW	REVISED -
PLOT DATE = 10/19/2011	CHECKED - BLM	REVISED -
	DATE - 10/14/11	REVISED -

STATE OF ILLINOIS
DEPARTMENT OF TRANSPORTATION

I-90 TEMPORARY LIGHTING PLAN
WISCONSIN CROSSOVER

SCALE: SHEET NO. OF SHEETS STA. TO STA.

F.A.I. RTE.	SECTION	COUNTY	TOTAL SHEETS	SHEET NO.
90	(X2-1)R	WINNEBAGO	510	258
CONTRACT NO. 64C29				
ILLINOIS FED. AID PROJECT				

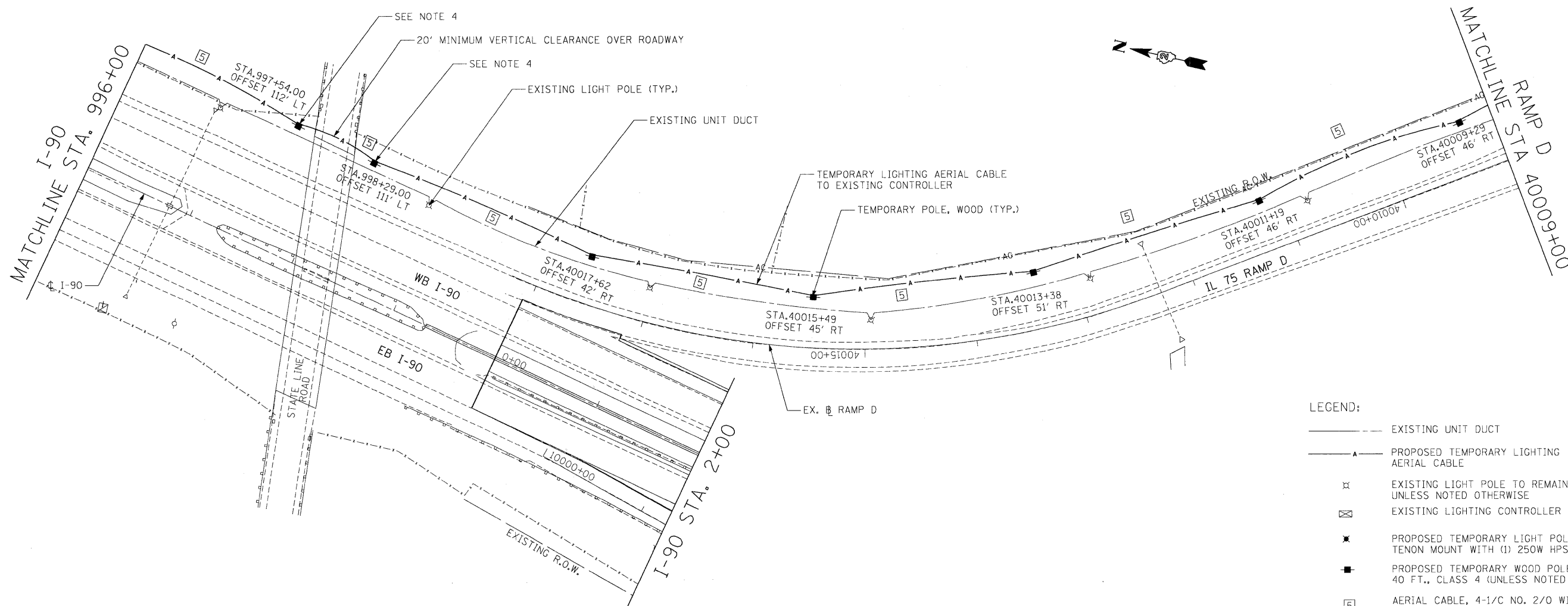

- LEGEND:**
- EXISTING UNIT DUCT
 - PROPOSED TEMPORARY LIGHTING AERIAL CABLE
 - ⊗ EXISTING LIGHT POLE TO REMAIN UNLESS NOTED OTHERWISE
 - ⊗ EXISTING LIGHTING CONTROLLER
 - ⊗ PROPOSED TEMPORARY LIGHT POLE, WOOD, 45 FT M.H. TENON MOUNT WITH (1) 250W HPS VAPOR FIXTURE
 - ⊗ PROPOSED TEMPORARY WOOD POLE, 40 FT., CLASS 4 (UNLESS NOTED OTHERWISE)
 - ⊗ AERIAL CABLE, 4-1/2 NO. 2/0 WITH MESSENGER WIRE

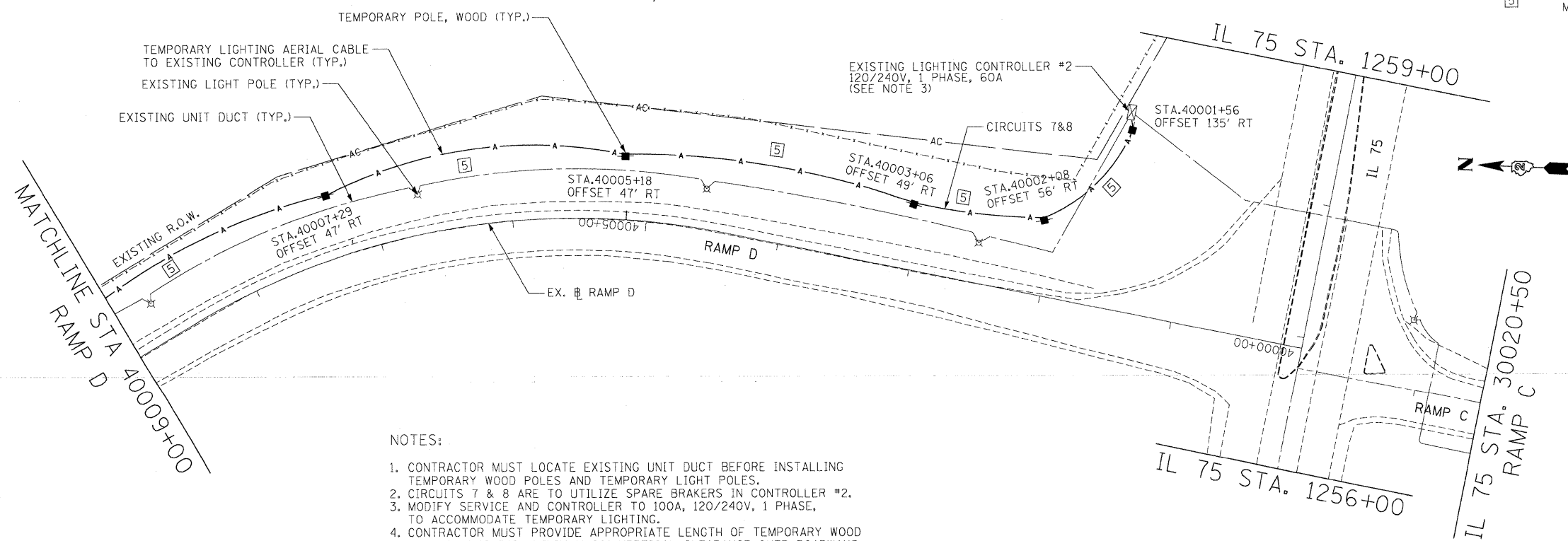

- NOTES:**
1. CONTRACTOR MUST LOCATE EXISTING UNIT DUCT BEFORE INSTALLING TEMPORARY WOOD POLES AND TEMPORARY LIGHT POLES.
 2. CIRCUITS 7 & 8 ARE TO UTILIZE SPARE BRAKERS IN CONTROLLER #2.
 3. MODIFY SERVICE AND CONTROLLER TO 100A, 120/240V, 1 PHASE, TO ACCOMMODATE TEMPORARY LIGHTING.
 4. CONTRACTOR MUST PROVIDE APPROPRIATE LENGTH OF TEMPORARY WOOD POLE TO MAINTAIN MINIMUM 20' VERTICAL CLEARANCE OVER ROADWAYS.

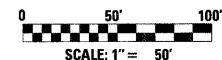

USER NAME = .USERNAME.	DESIGNED - BLM	REVISED -
PLOT SCALE = 50.0000' / IN.	DRAWN - JPW	REVISED -
PLOT DATE = 12/19/2011	CHECKED - BLM	REVISED -
	DATE - 10/14/11	REVISED -

**STATE OF ILLINOIS
DEPARTMENT OF TRANSPORTATION**

I-90 TEMPORARY LIGHTING PLAN WISCONSIN CROSSOVER			
SCALE:	SHEET NO.	OF SHEETS	STA. TO STA.

F.A.I. RTE.	SECTION	COUNTY	TOTAL SHEETS	SHEET NO.
90	(X2-1)R	WINNEBAGO	510	259
CONTRACT NO. 64C29				
ILLINOIS FED. AID PROJECT				

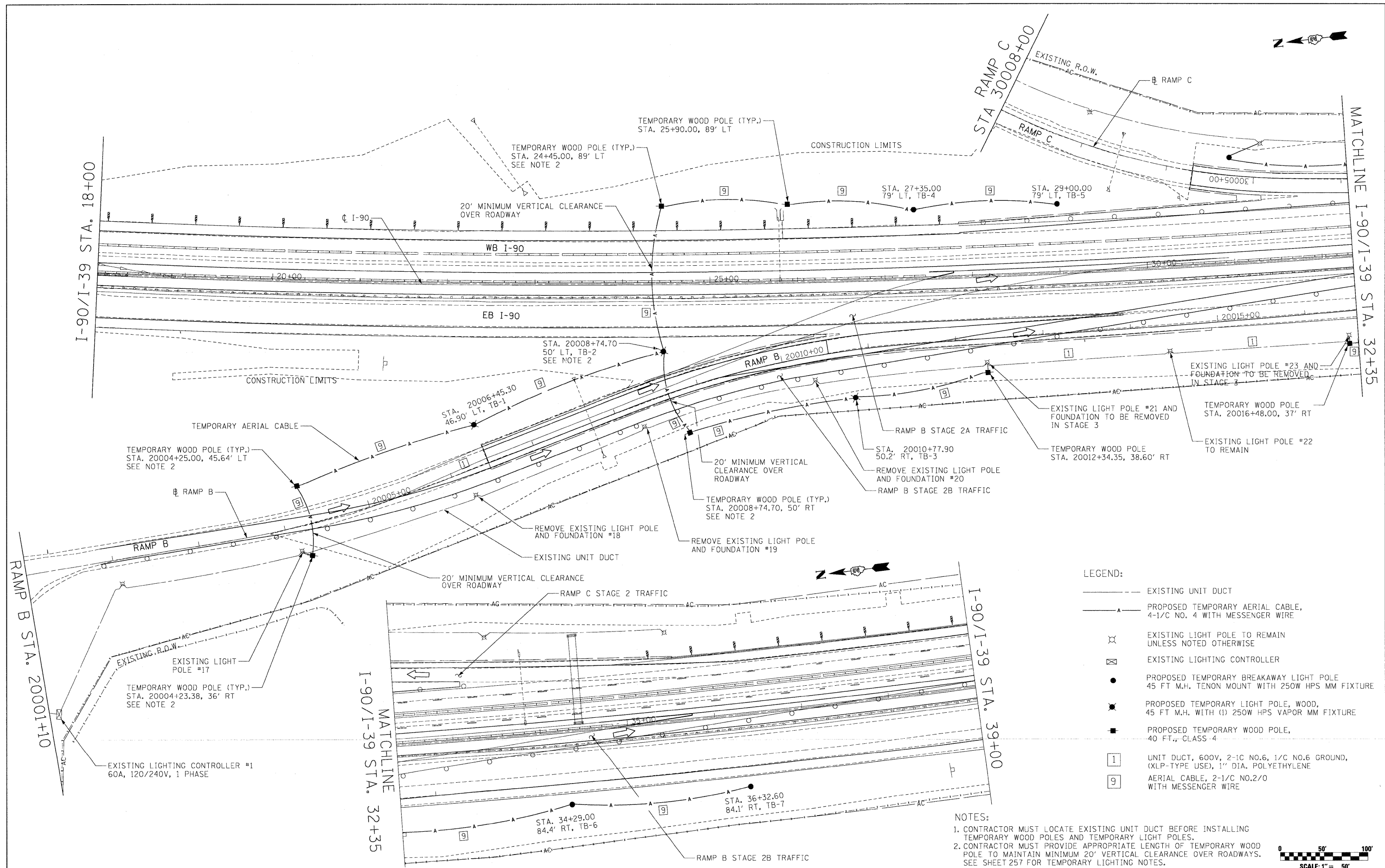

- LEGEND:**
- EXISTING UNIT DUCT
 - A- PROPOSED TEMPORARY AERIAL CABLE, 4-1/C NO. 4 WITH MESSENGER WIRE
 - ⊗ EXISTING LIGHT POLE TO REMAIN UNLESS NOTED OTHERWISE
 - ⊠ EXISTING LIGHTING CONTROLLER
 - PROPOSED TEMPORARY BREAKAWAY LIGHT POLE 45 FT M.H. TENON MOUNT WITH 250W HPS MM FIXTURE
 - ⊗ PROPOSED TEMPORARY LIGHT POLE, WOOD, 45 FT M.H. WITH (1) 250W HPS VAPOR MM FIXTURE
 - PROPOSED TEMPORARY WOOD POLE, 40 FT., CLASS 4
 - 1 UNIT DUCT, 600V, 2-1C NO.6, 1/C NO.6 GROUND, (XLP-TYPE USE), 1" DIA. POLYETHYLENE
 - 9 AERIAL CABLE, 2-1/C NO.2/0 WITH MESSENGER WIRE

NOTES:

- CONTRACTOR MUST LOCATE EXISTING UNIT DUCT BEFORE INSTALLING TEMPORARY WOOD POLES AND TEMPORARY LIGHT POLES.
- CONTRACTOR MUST PROVIDE APPROPRIATE LENGTH OF TEMPORARY WOOD POLE TO MAINTAIN MINIMUM 20' VERTICAL CLEARANCE OVER ROADWAYS. SEE SHEET 257 FOR TEMPORARY LIGHTING NOTES.

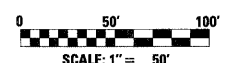

McClure LOCHNER
Engineering Services, Inc.
RWA
CHIEF ENGINEERING INC.

USER NAME = .USERNAME.	DESIGNED - BLM	REVISED -
PLOT SCALE = 50.0000' / IN.	DRAWN - JPW	REVISED -
PLOT DATE = 10/19/2011	CHECKED - BLM	REVISED -
	DATE - 10/14/11	REVISED -

**STATE OF ILLINOIS
DEPARTMENT OF TRANSPORTATION**

TEMPORARY LIGHTING PLAN IL 75 RAMP B			
SCALE:	SHEET NO.	OF SHEETS	STA. TO STA.

F.A.I. RTE.	SECTION	COUNTY	TOTAL SHEETS	SHEET NO.
90	(X2-1)R	WINNEBAGO	510	260
CONTRACT NO. 64C29				
[ILLINOIS] FED. AID PROJECT				

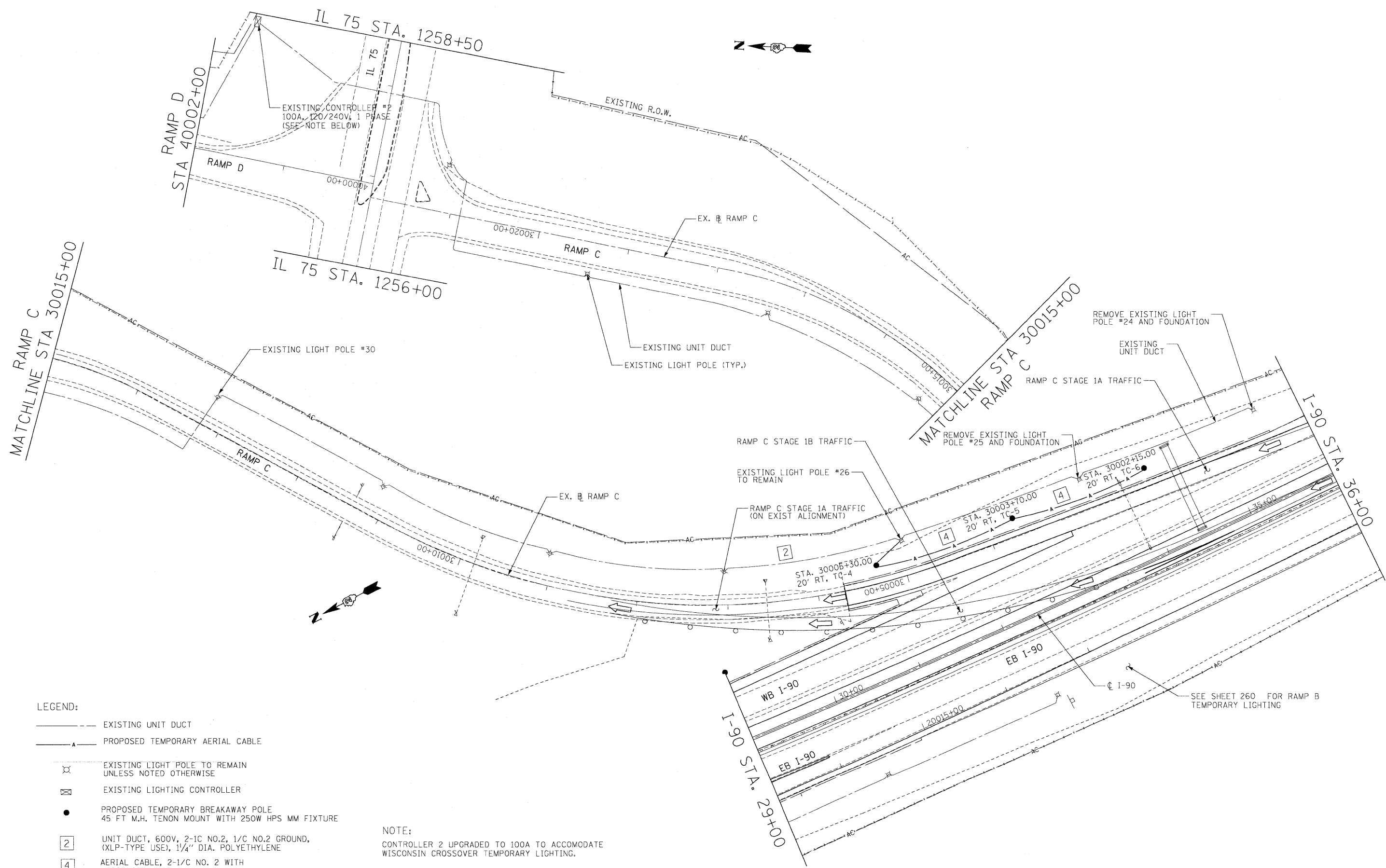

LEGEND:

- EXISTING UNIT DUCT
- - - PROPOSED TEMPORARY AERIAL CABLE
- ⊗ EXISTING LIGHT POLE TO REMAIN UNLESS NOTED OTHERWISE
- ⊠ EXISTING LIGHTING CONTROLLER
- PROPOSED TEMPORARY BREAKAWAY POLE 45 FT M.H. TENON MOUNT WITH 250W HPS MM FIXTURE
- 2 UNIT DUCT, 600V, 2-1C NO.2, 1/C NO.2 GROUND, (XLP-TYPE USE), 1/4" DIA. POLYETHYLENE
- 4 AERIAL CABLE, 2-1/C NO. 2 WITH MESSENGER WIRE

NOTE:
CONTROLLER 2 UPGRADED TO 100A TO ACCOMMODATE WISCONSIN CROSSOVER TEMPORARY LIGHTING.

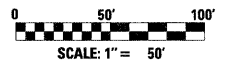

USER NAME = .USERNAME.	DESIGNED - BLM	REVISED -
PLOT SCALE = 50.0000' / IN.	DRAWN - JPW	REVISED -
PLOT DATE = 10/19/2011	CHECKED - BLM	REVISED -
	DATE - 10/14/11	REVISED -

**STATE OF ILLINOIS
DEPARTMENT OF TRANSPORTATION**

**TEMPORARY LIGHTING PLAN
IL 75 RAMP C**

SCALE:	SHEET NO.	OF	SHEETS	STA.	TO STA.
--------	-----------	----	--------	------	---------

F.A.J. RTE. 90	SECTION (X2-1)R	COUNTY WINNEBAGO	TOTAL SHEETS 510	SHEET NO. 261
CONTRACT NO. 64C29				
ILLINOIS FED. AID PROJECT				

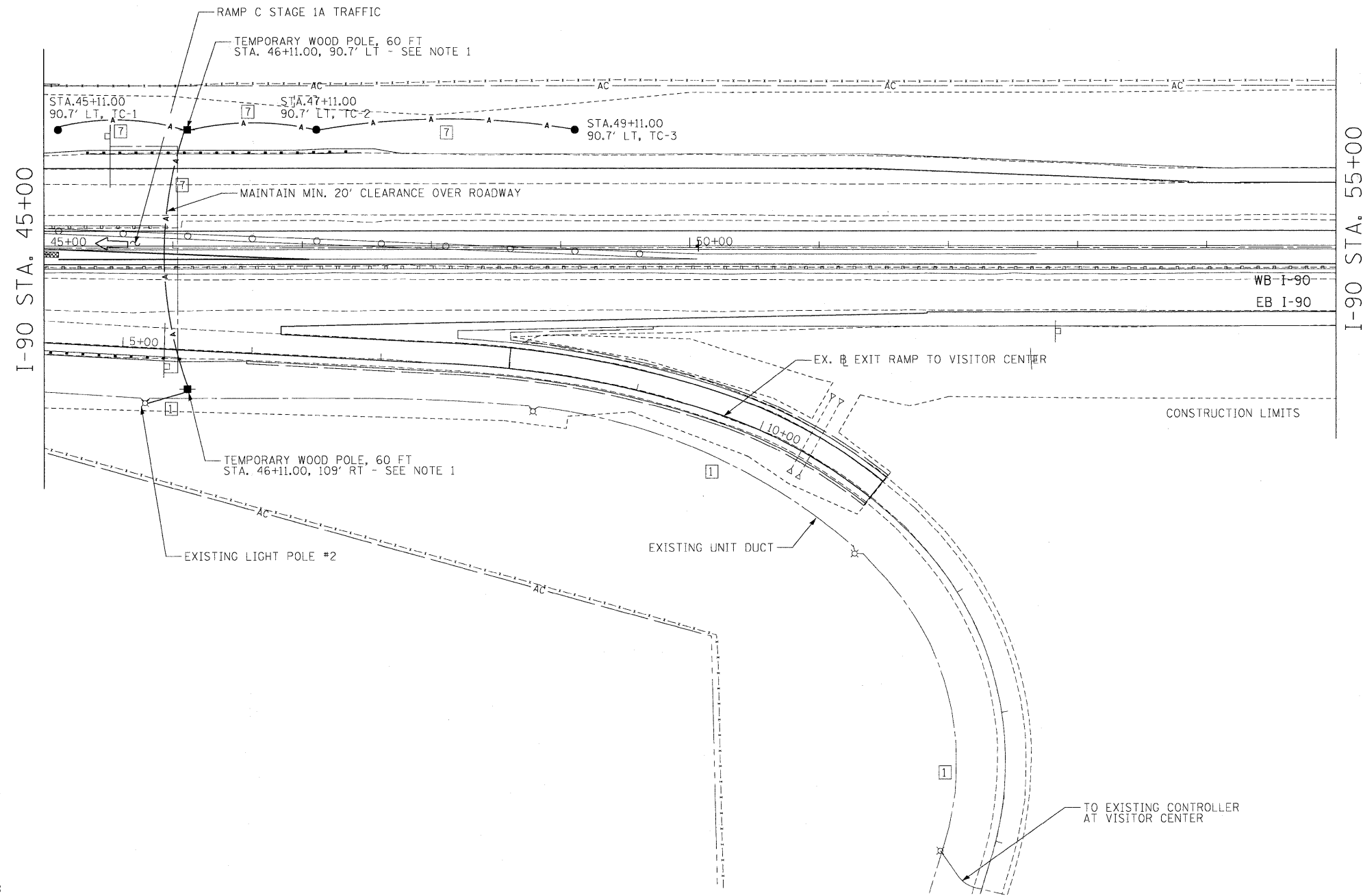
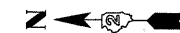

LEGEND:

- EXISTING UNIT DUCT
- A— PROPOSED TEMPORARY AERIAL CABLE
- ⊗ EXISTING LIGHT POLE TO REMAIN UNLESS NOTED OTHERWISE
- ⊗ EXISTING LIGHTING CONTROLLER
- PROPOSED TEMPORARY WOOD POLE, 40 FT., CLASS 4 (UNLESS OTHERWISE NOTED)
- PROPOSED TEMPORARY BREAKAWAY LIGHT POLE 50 FT M.H. TENON MOUNT WITH 400W HPS MM FIXTURE
- 7 AERIAL CABLE, 2-1/8 NO.6 WITH MESSENGER WIRE

NOTES:

1. CONTRACTOR MUST PROVIDE APPROPRIATE LENGTH OF TEMPORARY WOOD POLE TO MAINTAIN MINIMUM 20' VERTICAL CLEARANCE OVER ROADWAY.
2. TEMPORARY LIGHTING NOT TO BE ACTIVATED UNTIL EXISTING LIGHT POLES 1 THRU 5 OF VISITOR CENTER EXIT RAMP HAVE BEEN REMOVED FROM THE CIRCUIT.



McClure LOCHNER
Engineering Associates, Inc.
NEW LOCHNER, INC. CHICAGO, ILLINOIS

RWA
RWA ENGINEERING & ARCHITECTURE, INC.

QEI
QUIGG ENGINEERING INC.

USER NAME = .USERNAME.	DESIGNED - BLM	REVISED -
	DRAWN - JPW	REVISED -
PLOT SCALE = 50.0000' / IN.	CHECKED - BLM	REVISED -
PLOT DATE = 10/20/2011	DATE - 10/14/11	REVISED -

**STATE OF ILLINOIS
DEPARTMENT OF TRANSPORTATION**

TEMPORARY LIGHTING PLAN IL 75 RAMP C				
SCALE:	SHEET NO.	OF SHEETS	STA.	TO STA.

F.A.I. RTE.	SECTION	COUNTY	TOTAL SHEETS	SHEET NO.
90	(X2-1)R	WINNEBAGO	510	262
CONTRACT NO. 64C29				
ILLINOIS FED. AID PROJECT				

SEE SHEET 264 FOR CONTINUATION OF ENTRANCE RAMP TEMPORARY LIGHTING

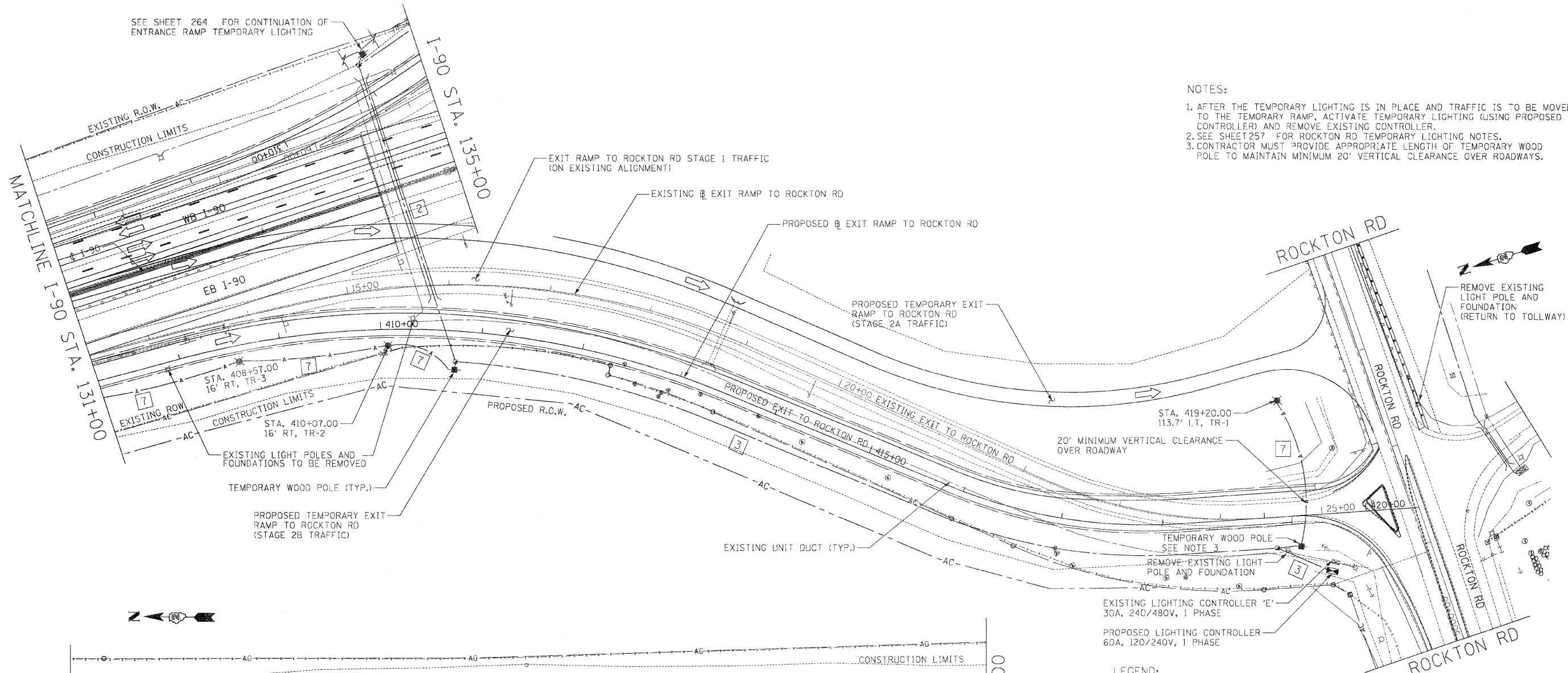

- NOTES:
1. AFTER THE TEMPORARY LIGHTING IS IN PLACE AND TRAFFIC IS TO BE MOVED TO THE TEMPORARY RAMP, ACTIVATE TEMPORARY LIGHTING (USING PROPOSED CONTROLLER) AND REMOVE EXISTING CONTROLLER.
 2. SEE SHEET 257 FOR ROCKTON RD TEMPORARY LIGHTING NOTES.
 3. CONTRACTOR MUST PROVIDE APPROPRIATE LENGTH OF TEMPORARY WOOD POLE TO MAINTAIN MINIMUM 20' VERTICAL CLEARANCE OVER ROADWAYS.

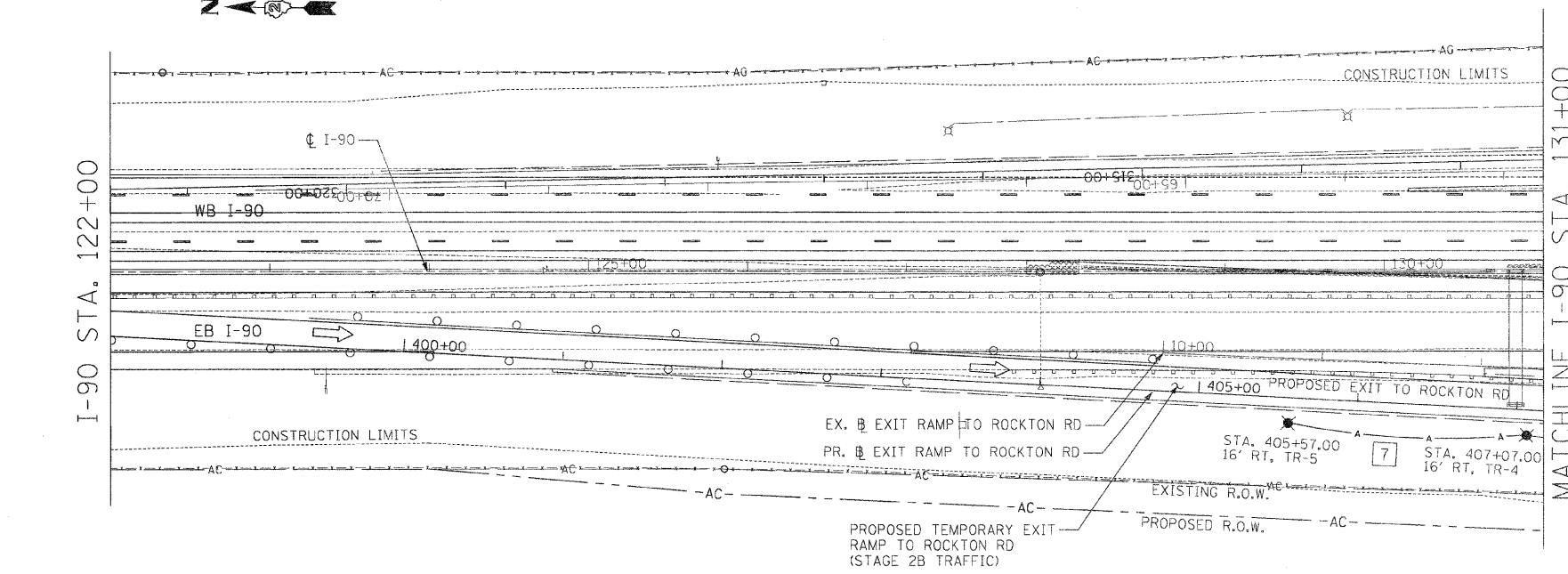

- LEGEND:
- EXISTING UNIT DUCT
 - PROPOSED TEMPORARY LIGHTING AERIAL CABLE
 - ⊗ EXISTING LIGHT POLE TO REMAIN UNLESS NOTED OTHERWISE
 - ⊗ EXISTING LIGHTING CONTROLLER
 - ⊗ PROPOSED LIGHTING CONTROLLER
 - ⊗ PROPOSED TEMPORARY LIGHT POLE, WOOD, 45 FT. M.H. TENON MOUNT WITH (1) 250W HPS VAPOR FIXTURE
 - ⊗ PROPOSED TEMPORARY WOOD POLE, 40 FT., CLASS 4
 - ⊗ PROPOSED HAND HOLE
 - 1 UNIT DUCT, 600V, 2-1C NO.6, 1/C NO.6 GROUND, (XLP-TYPE USE), 1" DIA. POLYETHYLENE
 - 2 UNIT DUCT, 600V, 2-1C NO.2, 1/C NO.2 GROUND, (XLP-TYPE USE), 1 1/4" DIA. POLYETHYLENE
 - 3 UNIT DUCT, 600V, 4-1C NO.2, 1C NO.4 GROUND, (XLP-TYPE USE), 1 1/2" DIA. POLYETHYLENE
 - 7 AERIAL CABLE, 2-1/C NO.6 WITH MESSENGER WIRE
 - CONDUIT PUSHED, 4" DIA., PVC SCHEDULE 80 (PAID AS UNDERGROUND CONDUIT, PVC, 4" DIA.)

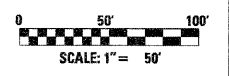

	USER NAME = _USERNAME_	DESIGNED - BLM	REVISED -	STATE OF ILLINOIS DEPARTMENT OF TRANSPORTATION	TEMPORARY LIGHTING PLAN ROCKTON RD EXIT RAMP	F.A.I. RTE. 90	SECTION (K2-1R)	COUNTY WINNEBAGO	TOTAL SHEETS 510	SHEET NO. 263
	PLOT SCALE = 50.0000' / IN.	CHECKED - BLM	REVISED -			SCALE:	SHEET NO. OF SHEETS STA. TO STA.	CONTRACT NO. 64C29	(ILLINOIS) FED. AID PROJECT	
	PLOT DATE = 12/25/2011	DATE = 10/14/11	REVISED -							

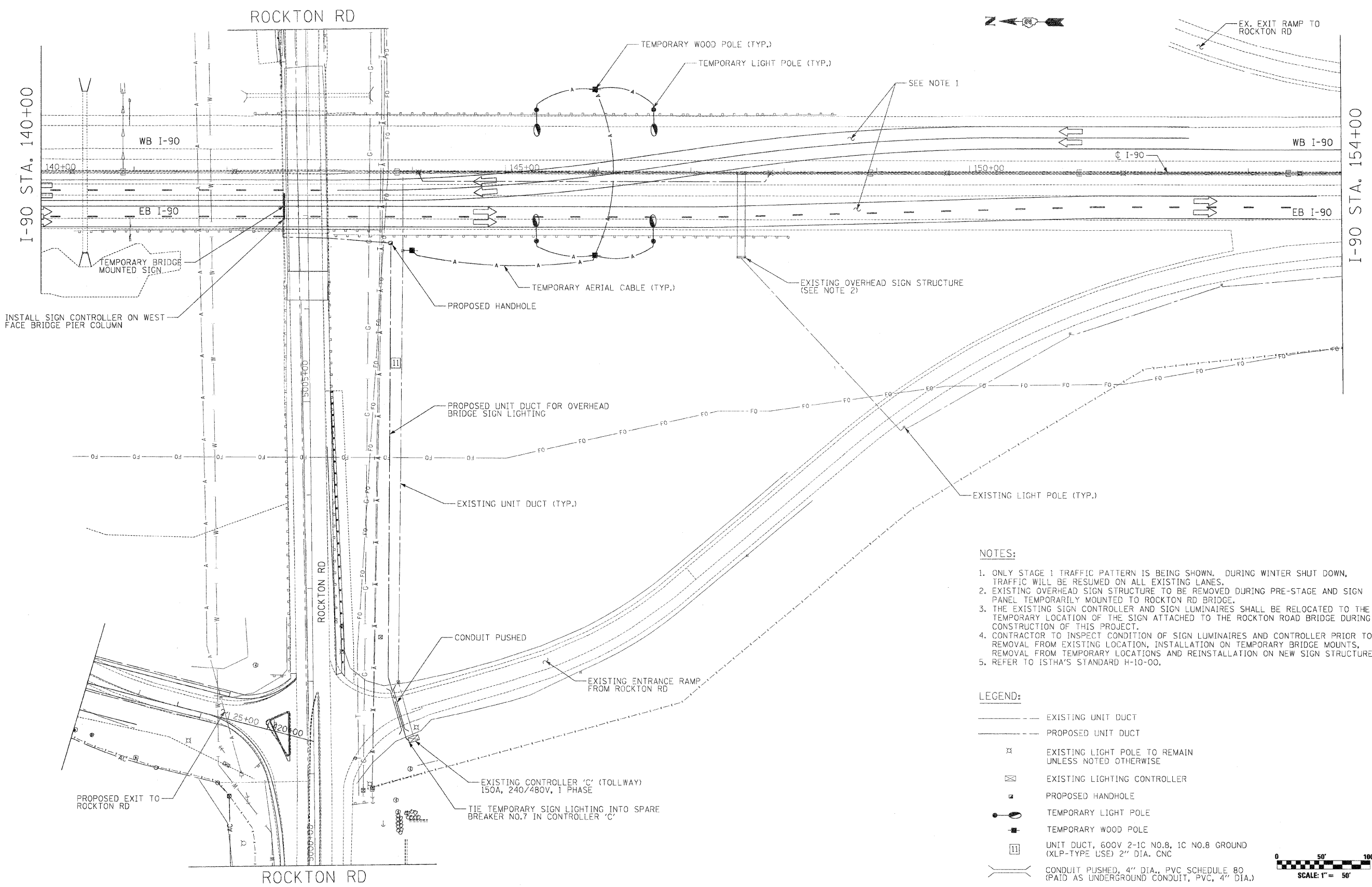

NOTES:

1. ONLY STAGE 1 TRAFFIC PATTERN IS BEING SHOWN. DURING WINTER SHUT DOWN, TRAFFIC WILL BE RESUMED ON ALL EXISTING LANES.
2. EXISTING OVERHEAD SIGN STRUCTURE TO BE REMOVED DURING PRE-STAGE AND SIGN PANEL TEMPORARILY MOUNTED TO ROCKTON RD BRIDGE.
3. THE EXISTING SIGN CONTROLLER AND SIGN LUMINAIRES SHALL BE RELOCATED TO THE TEMPORARY LOCATION OF THE SIGN ATTACHED TO THE ROCKTON ROAD BRIDGE DURING CONSTRUCTION OF THIS PROJECT.
4. CONTRACTOR TO INSPECT CONDITION OF SIGN LUMINAIRES AND CONTROLLER PRIOR TO REMOVAL FROM EXISTING LOCATION, INSTALLATION ON TEMPORARY BRIDGE MOUNTS, REMOVAL FROM TEMPORARY LOCATIONS AND REINSTALLATION ON NEW SIGN STRUCTURE.
5. REFER TO ISTHA'S STANDARD H-10-00.

LEGEND:

- EXISTING UNIT DUCT
- - - PROPOSED UNIT DUCT
- ⊗ EXISTING LIGHT POLE TO REMAIN UNLESS NOTED OTHERWISE
- ⊠ EXISTING LIGHTING CONTROLLER
- PROPOSED HANDHOLE
- ⊙ TEMPORARY LIGHT POLE
- ⊕ TEMPORARY WOOD POLE
- ▭ UNIT DUCT, 600V 2-1C NO.8, 1C NO.8 GROUND (XLP-TYPE USE) 2" DIA. CNC
- CONDUIT PUSHED, 4" DIA., PVC SCHEDULE 80 (PAID AS UNDERGROUND CONDUIT, PVC, 4" DIA.)

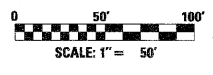

	LOCHNER	USER NAME = .USERNAME.	DESIGNED - BLM	REVISED -	STATE OF ILLINOIS DEPARTMENT OF TRANSPORTATION	TEMPORARY LIGHTING PLAN		F.A.I. RTE.	SECTION	COUNTY	TOTAL SHEETS	SHEET NO.	
			PLOT SCALE = 5/8" = 1' / IN.	DRAWN - JPW		REVISED -	BRIDGE MOUNTED SIGN STRUCTURE STAGE 1 & WINTER SHUT DOWN	90	(X2-11R)	WINNEBAGO	510	266	
		PLOT DATE = 10/25/2011	CHECKED - BLM	REVISED -	SCALE: SHEET NO. OF SHEETS STA. TO STA.			CONTRACT NO. 64C29					
			DATE - 10/14/11	REVISED -					ILLINOIS FED. AID PROJECT				

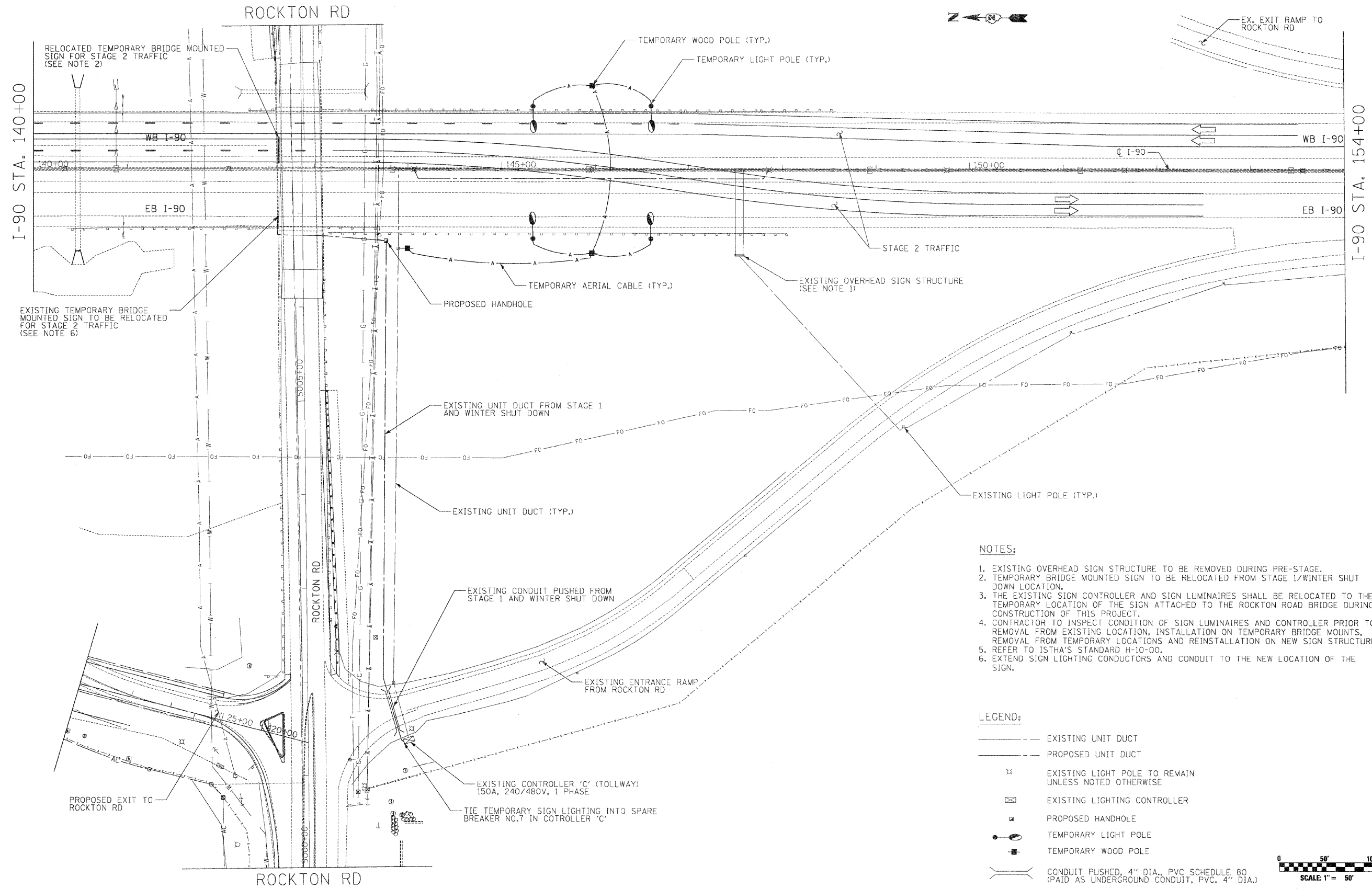

NOTES:

1. EXISTING OVERHEAD SIGN STRUCTURE TO BE REMOVED DURING PRE-STAGE.
2. TEMPORARY BRIDGE MOUNTED SIGN TO BE RELOCATED FROM STAGE 1/WINTER SHUT DOWN LOCATION.
3. THE EXISTING SIGN CONTROLLER AND SIGN LUMINAIRES SHALL BE RELOCATED TO THE TEMPORARY LOCATION OF THE SIGN ATTACHED TO THE ROCKTON ROAD BRIDGE DURING CONSTRUCTION OF THIS PROJECT.
4. CONTRACTOR TO INSPECT CONDITION OF SIGN LUMINAIRES AND CONTROLLER PRIOR TO REMOVAL FROM EXISTING LOCATION, INSTALLATION ON TEMPORARY BRIDGE MOUNTS, REMOVAL FROM TEMPORARY LOCATIONS AND REINSTALLATION ON NEW SIGN STRUCTURE.
5. REFER TO ISTHA'S STANDARD H-10-00.
6. EXTEND SIGN LIGHTING CONDUCTORS AND CONDUIT TO THE NEW LOCATION OF THE SIGN.

LEGEND:

- EXISTING UNIT DUCT
- - - PROPOSED UNIT DUCT
- ⊗ EXISTING LIGHT POLE TO REMAIN UNLESS NOTED OTHERWISE
- ⊠ EXISTING LIGHTING CONTROLLER
- PROPOSED HANDHOLE
- TEMPORARY LIGHT POLE
- TEMPORARY WOOD POLE
- CONDUIT PUSHED, 4" DIA., PVC SCHEDULE 80 (PAID AS UNDERGROUND CONDUIT, PVC, 4" DIA.)



USER NAME = _USERNAME_	DESIGNED - BLM	REVISED -
	DRAWN - JPW	REVISED -
PLOT SCALE = 50.0000' / IN.	CHECKED - BLM	REVISED -
PLOT DATE = 10/25/2011	DATE - 10/14/11	REVISED -

STATE OF ILLINOIS
DEPARTMENT OF TRANSPORTATION

TEMPORARY LIGHTING PLAN			
BRIDGE MOUNTED SIGN STRUCTURE STAGE 2			
SCALE:	SHEET NO.	OF SHEETS	STA. TO STA.

F.A.I. R.I.E.	SECTION	COUNTY	TOTAL SHEETS	SHEET NO.
90	(X2-1)R	WINNEBAGO	510	267
CONTRACT NO. 64C29			ILLINOIS FED. AID PROJECT	

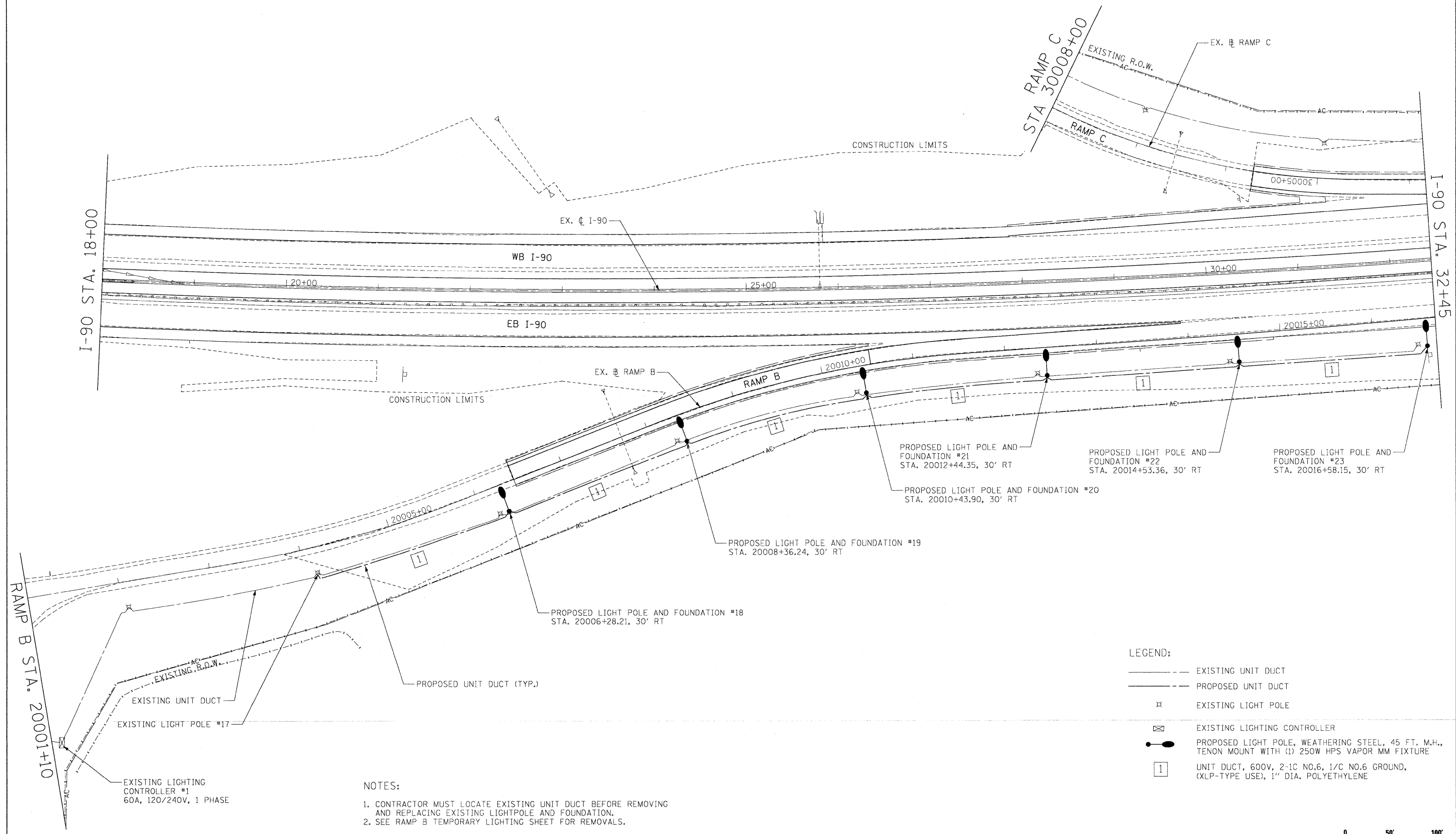

EXISTING LIGHTING CONTROLLER #1
60A, 120/240V, 1 PHASE

- NOTES:
1. CONTRACTOR MUST LOCATE EXISTING UNIT DUCT BEFORE REMOVING AND REPLACING EXISTING LIGHTPOLE AND FOUNDATION.
 2. SEE RAMP B TEMPORARY LIGHTING SHEET FOR REMOVALS.

- LEGEND:
- EXISTING UNIT DUCT
 - - - PROPOSED UNIT DUCT
 - ⊗ EXISTING LIGHT POLE
 - ⊗ EXISTING LIGHTING CONTROLLER
 - PROPOSED LIGHT POLE, WEATHERING STEEL, 45 FT. M.H., TENON MOUNT WITH (1) 250W HPS VAPOR MM FIXTURE
 - 1 UNIT DUCT, 600V, 2-1C NO.6, 1/C NO.6 GROUND, (XLP-TYPE USE), 1" DIA. POLYETHYLENE

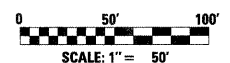

USER NAME = .USERNAME.	DESIGNED - BLM	REVISED -
PLOT SCALE = 50.0000' / IN.	DRAWN - JPW	REVISED -
PLOT DATE = 10/19/2011	CHECKED - BLM	REVISED -
	DATE - 10/14/11	REVISED -

**STATE OF ILLINOIS
DEPARTMENT OF TRANSPORTATION**

**LIGHTING PLAN IL 75
RAMP B**

SCALE: SHEET NO. OF SHEETS STA. TO STA.

F.A.I. RTE. 90	SECTION (X2-1)R	COUNTY WINNEBAGO	TOTAL SHEETS 510	SHEET NO. 268
CONTRACT NO. 64C29			ILLINOIS FED. AID PROJECT	

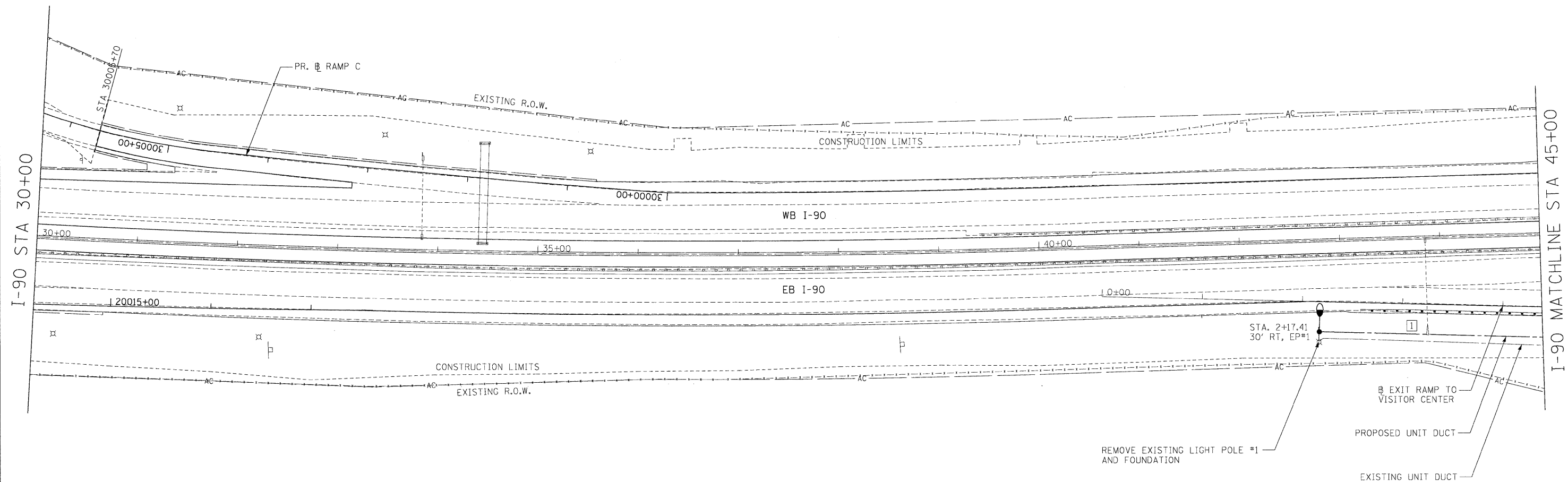

NOTE:
 CONTRACTOR MUST LOCATE EXISTING UNIT DUCT BEFORE REMOVING
 AND REPLACING EXISTING LIGHT POLE AND FOUNDATION.

- LEGEND:
- EXISTING UNIT DUCT
 - - - PROPOSED UNIT DUCT
 - ⊠ EXISTING LIGHT POLE TO REMAIN UNLESS NOTED OTHERWISE
 - PROPOSED LIGHT POLE, WEATHERING STEEL, 45 FT. M.H., TENON MOUNT WITH (1) 400W HPS VAPOR MM FIXTURE
 - 1 UNIT DUCT, 600V, 2-1C NO.6, 1/C NO.6 GROUND, (XLP-TYPE USE), 1" DIA. POLYETHYLENE

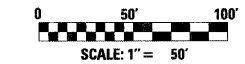

 	USER NAME = _USERNAME_	DESIGNED - BLM	REVISED -	STATE OF ILLINOIS DEPARTMENT OF TRANSPORTATION	LIGHTING PLAN VISITOR CENTER EXIT RAMP			F.A.I. RTE. 90	SECTION (X2-1R)	COUNTY WINNEBAGO	TOTAL SHEETS 510	SHEET NO. 270
	PLOT SCALE = 50.0000' / IN.	CHECKED - BLM	DATE - 10/14/11		REVISED -	SCALE:	SHEET NO. OF SHEETS	STA. TO STA.	CONTRACT NO. 64C29 ILLINOIS FED. AID PROJECT			

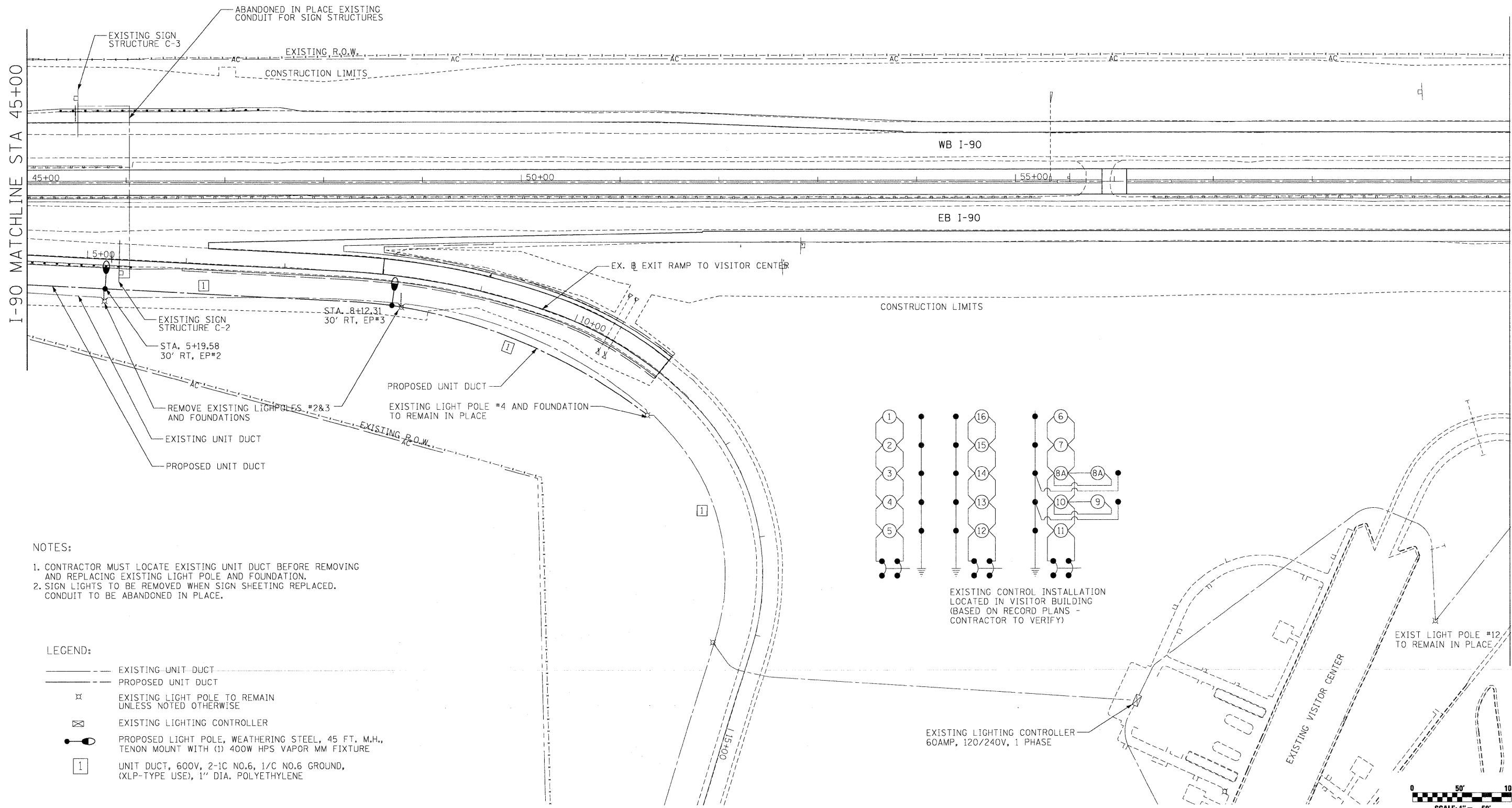

- NOTES:
1. CONTRACTOR MUST LOCATE EXISTING UNIT DUCT BEFORE REMOVING AND REPLACING EXISTING LIGHT POLE AND FOUNDATION.
 2. SIGN LIGHTS TO BE REMOVED WHEN SIGN SHEETING REPLACED. CONDUIT TO BE ABANDONED IN PLACE.

- LEGEND:
- EXISTING UNIT DUCT
 - - - PROPOSED UNIT DUCT
 - ⊗ EXISTING LIGHT POLE TO REMAIN UNLESS NOTED OTHERWISE
 - ⊗ EXISTING LIGHTING CONTROLLER
 - ⊙ PROPOSED LIGHT POLE, WEATHERING STEEL, 45 FT. M.H., TENON MOUNT WITH (1) 400W HPS VAPOR MM FIXTURE
 - 1 UNIT DUCT, 600V, 2-1C NO.6, 1/C NO.6 GROUND, (XLP-TYPE USE), 1" DIA. POLYETHYLENE

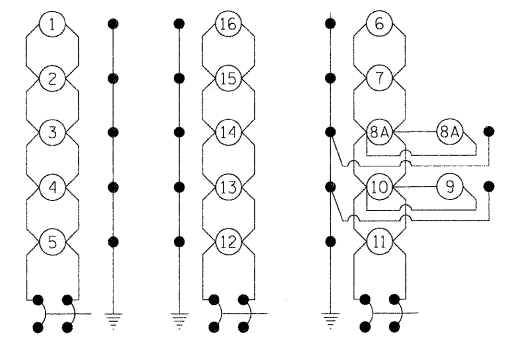

EXISTING CONTROL INSTALLATION LOCATED IN VISITOR BUILDING (BASED ON RECORD PLANS - CONTRACTOR TO VERIFY)

EXISTING LIGHTING CONTROLLER 60AMP, 120/240V, 1 PHASE

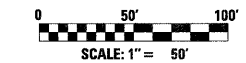

USER NAME = .USERNAME.	DESIGNED - BLM	REVISED -
	DRAWN - JPW	REVISED -
PLOT SCALE = 50.0000' / IN.	CHECKED - BLM	REVISED -
PLOT DATE = 10/19/2011	DATE - 10/14/11	REVISED -

**STATE OF ILLINOIS
DEPARTMENT OF TRANSPORTATION**

**LIGHTING PLAN
VISITOR CENTER EXIT RAMP**

SCALE: SHEET NO. OF SHEETS STA. TO STA.

F.A.I. RTE.	SECTION	COUNTY	TOTAL SHEETS	SHEET NO.
90	(X2-1JR)	WINNEBAGO	510	271
CONTRACT NO. 64C29				
ILLINOIS FED. AID PROJECT				

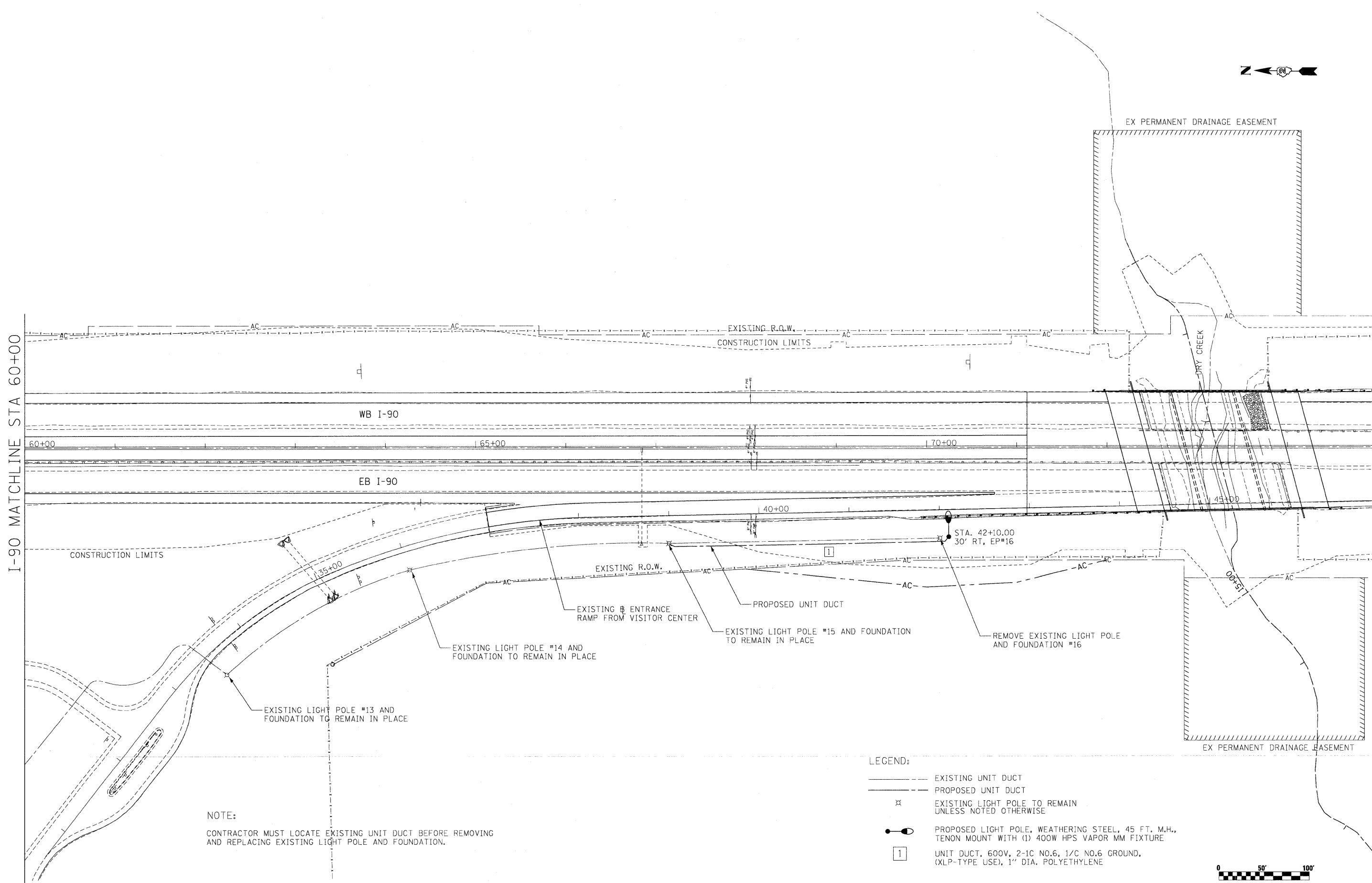

NOTE:
CONTRACTOR MUST LOCATE EXISTING UNIT DUCT BEFORE REMOVING AND REPLACING EXISTING LIGHT POLE AND FOUNDATION.

- LEGEND:
- EXISTING UNIT DUCT
 - PROPOSED UNIT DUCT
 - ⊠ EXISTING LIGHT POLE TO REMAIN UNLESS NOTED OTHERWISE
 - PROPOSED LIGHT POLE, WEATHERING STEEL, 45 FT. M.H., TENON MOUNT WITH (1) 400W HPS VAPOR MM FIXTURE
 - 1 UNIT DUCT, 600V, 2-1C NO.6, 1/2" NO.6 GROUND, (XLP-TYPE USE), 1" DIA. POLYETHYLENE

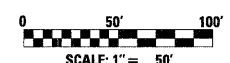

USER NAME = .USERNAME.	DESIGNED - BLM	REVISED -
PLOT SCALE = 50,000' / IN.	DRAWN - JPW	REVISED -
PLOT DATE = 10/19/2011	CHECKED - BLM	REVISED -
	DATE - 10/14/11	REVISED -

**STATE OF ILLINOIS
DEPARTMENT OF TRANSPORTATION**

LIGHTING PLAN			
VISITOR CENTER ENTRANCE RAMP			
SCALE:	SHEET NO.	OF SHEETS	STA. TO STA.

F.A.I. RTE.	SECTION	COUNTY	TOTAL SHEETS	SHEET NO.
90	(X2-1)R	WINNEBAGO	510	272
CONTRACT NO. 64C29			ILLINOIS FED. AID PROJECT	

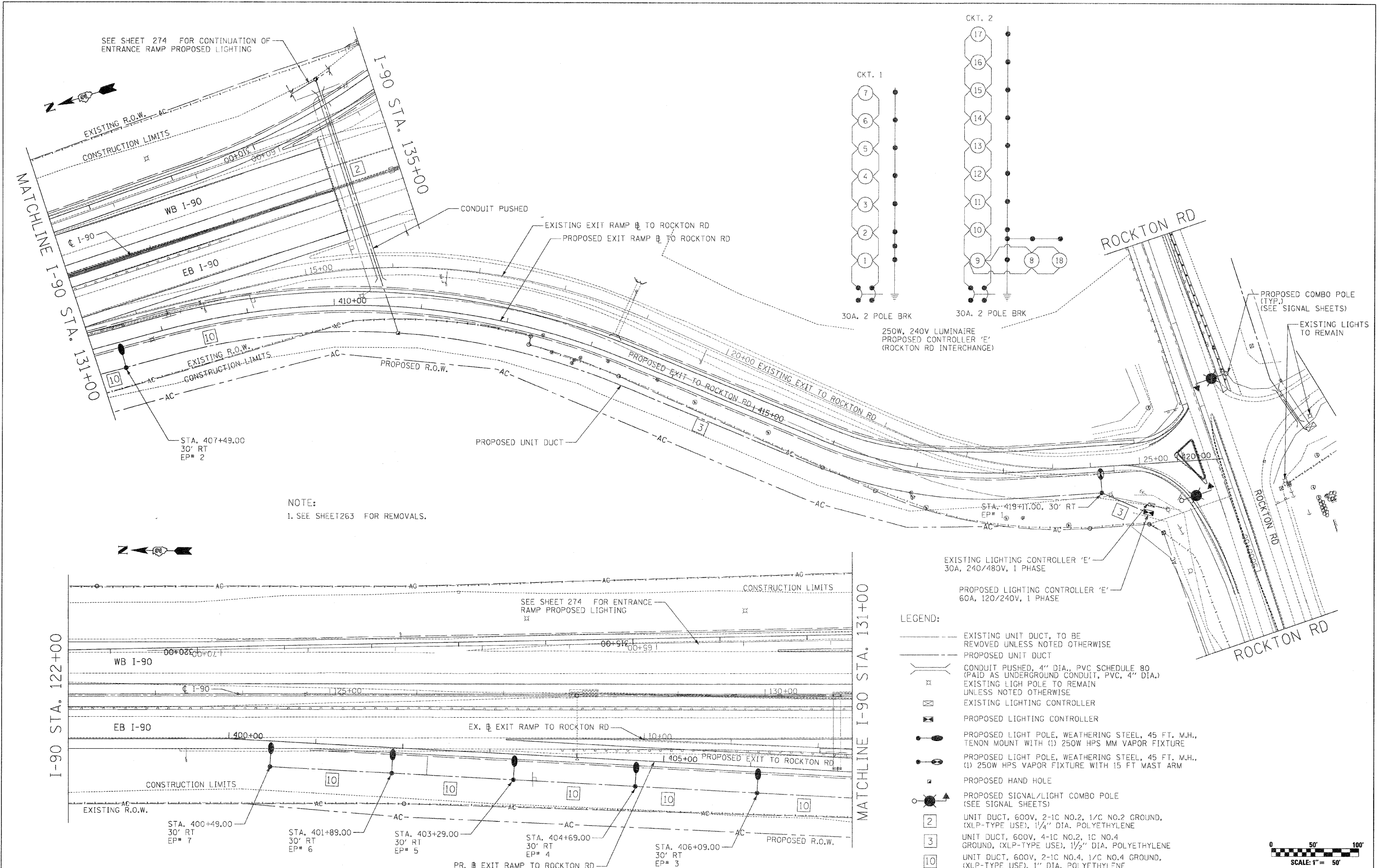

NOTE:
1. SEE SHEET 263 FOR REMOVALS.

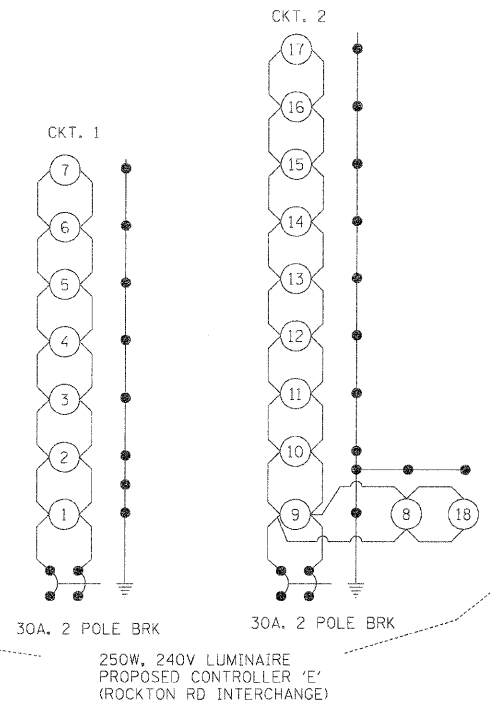

EXISTING LIGHTING CONTROLLER 'E'
30A, 240/480V, 1 PHASE

PROPOSED LIGHTING CONTROLLER 'E'
60A, 120/240V, 1 PHASE

- LEGEND:
- EXISTING UNIT DUCT, TO BE REMOVED UNLESS NOTED OTHERWISE
 - - - PROPOSED UNIT DUCT
 - CONDUIT PUSHED, 4" DIA., PVC SCHEDULE 80 (PAID AS UNDERGROUND CONDUIT, PVC, 4" DIA.)
 - ⊠ EXISTING LIGHT POLE TO REMAIN UNLESS NOTED OTHERWISE
 - ⊠ EXISTING LIGHTING CONTROLLER
 - ⊠ PROPOSED LIGHTING CONTROLLER
 - PROPOSED LIGHT POLE, WEATHERING STEEL, 45 FT. M.H., TENON MOUNT WITH (1) 250W HPS MM VAPOR FIXTURE
 - PROPOSED LIGHT POLE, WEATHERING STEEL, 45 FT. M.H., (1) 250W HPS VAPOR FIXTURE WITH 15 FT MAST ARM
 - PROPOSED HAND HOLE
 - ⊠ PROPOSED SIGNAL/LIGHT COMBO POLE (SEE SIGNAL SHEETS)
 - 2 UNIT DUCT, 600V, 2-1C NO.2, 1/C NO.2 GROUND, (XLP-TYPE USE), 1/4" DIA. POLYETHYLENE
 - 3 UNIT DUCT, 600V, 4-1C NO.2, 1C NO.4 GROUND, (XLP-TYPE USE), 1/2" DIA. POLYETHYLENE
 - 10 UNIT DUCT, 600V, 2-1C NO.4, 1/C NO.4 GROUND, (XLP-TYPE USE), 1" DIA. POLYETHYLENE

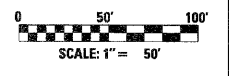

	USER NAME = _USERNAME_	DESIGNED - BLM	REVISED -	STATE OF ILLINOIS DEPARTMENT OF TRANSPORTATION	LIGHTING PLAN ROCKTON RD EXIT RAMP		F.A.I. RTE. 90	SECTION (X2-1)R	COUNTY WINNEBAGO	TOTAL SHEETS 510	SHEET NO. 273
			DRAWN - JPW CHECKED - BLM DATE - 10/14/11		REVISED - REVISED - REVISED -	SCALE: SHEET NO. OF SHEETS STA. TO STA.	CONTRACT NO. 64C29	ILLINOIS FED. AID PROJECT			

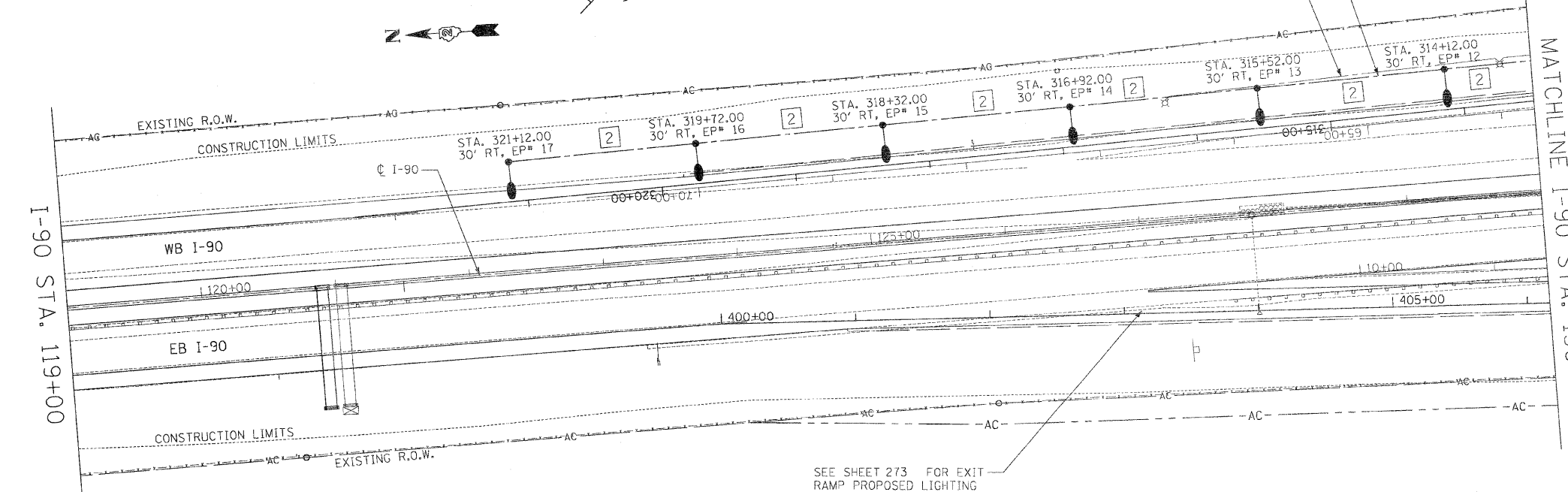
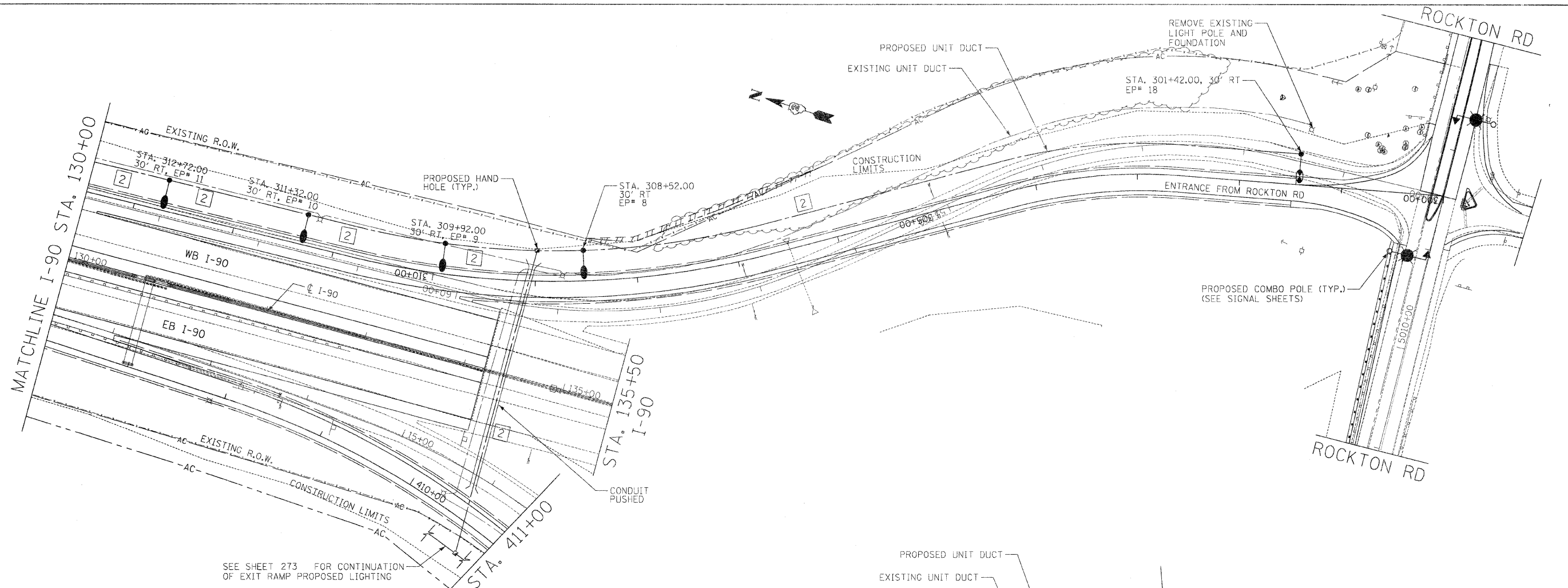

NOTE:
SEE SHEET 264 FOR REMOVALS.

- LEGEND:
- EXISTING UNIT DUCT, TO BE REMOVED UNLESS NOTED OTHERWISE
 - PROPOSED UNIT DUCT
 - CONDUIT PUSHED, 4" DIA., PVC SCHEDULE 80 (PAID AS UNDERGROUND CONDUIT, PVC, 4" DIA.)
 - EXISTING LIGHT POLE TO REMAIN UNLESS NOTED OTHERWISE
 - PROPOSED LIGHT POLE, WEATHERING STEEL, 45 FT. M.H., TENON MOUNT WITH (1) 250W HPS MM VAPOR FIXTURE
 - PROPOSED LIGHT POLE, WEATHERING STEEL, 45 FT. M.H., (1) 250W HPS VAPOR FIXTURE WITH 15 FT MAST ARM
 - PROPOSED HAND HOLE
 - PROPOSED SIGNAL/LIGHT COMBO POLE (SEE SIGNAL SHEETS)
 - UNIT DUCT, 600V, 2-1C NO.2, 1/C NO.2 GROUND, (XLP-TYPE USE), 1/4" DIA. POLYETHYLENE

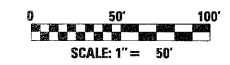

McClure
LOCHNER
RWA
OEI

USER NAME = _USERNAME_	DESIGNED - BLM	REVISED -
PLOT SCALE = 50.0000' / IN.	DRAWN - JPW	REVISED -
PLOT DATE = 10/25/2011	CHECKED - BLM	REVISED -
	DATE - 10/14/11	REVISED -

STATE OF ILLINOIS
DEPARTMENT OF TRANSPORTATION

LIGHTING PLAN			
ROCKTON RD ENTRANCE RAMP			
SCALE:	SHEET NO.	OF SHEETS	STA. TO STA.

F.A.I. RTE.	SECTION	COUNTY	TOTAL SHEETS	SHEET NO.
90	(X2-1)R	WINNEBAGO	510	274
CONTRACT NO. 64C29				
ILLINOIS FED. AID PROJECT				

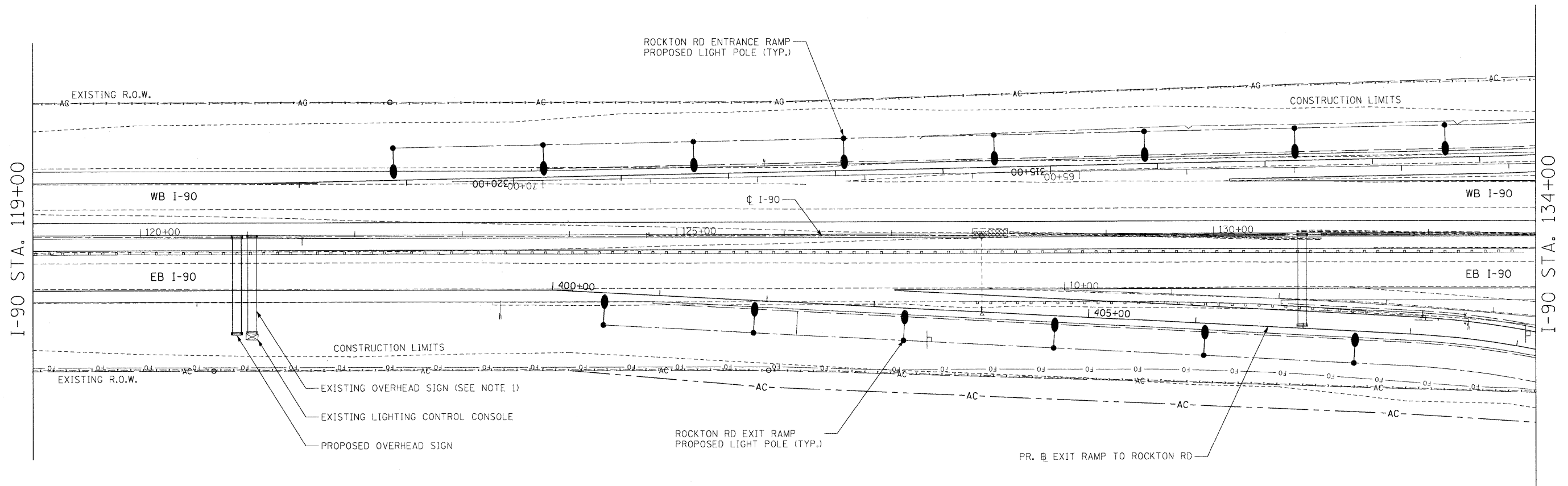
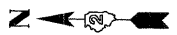

NOTES:

1. EXISTING OVERHEAD SIGN STRUCTURE TO BE REMOVED DURING PRE-STAGE.
2. THE RELOCATED SIGN WILL NOT BE LIGHTED DURING CONSTRUCTION OF THIS PROJECT. THE CONTRACTOR SHALL BE RESPONSIBLE FOR STORING THE SIGN LIGHTING LUMINAIRES AND CONTROLLER UNTIL SUCH TIME THAT THE SIGN PANELS AND LUMINAIRES CAN BE REINSTALLED ON THE NEW STRUCTURE.
3. CONTRACTOR TO INSPECT CONDITION OF SIGN LUMINAIRES AND CONTROLLER PRIOR TO REMOVAL FROM EXISTING LOCATION AND REINSTALLATION ON NEW SIGN STRUCTURE.
4. PROVIDING SERVICE FOR THE CONTROLLER IS NOT INCLUDED THIS CONTRACT. THEREFORE, THE CONTROLLER AND SIGN LIGHTS SHALL BE REINSTALLED BUT NOT ENERGIZED UNLESS DIRECTED BY ISTHA.

LEGEND:

- EXISTING UNIT DUCT
- PROPOSED UNIT DUCT
- ⊠ EXISTING LIGHT POLE TO REMAIN UNLESS NOTED OTHERWISE
- PROPOSED LIGHT POLE

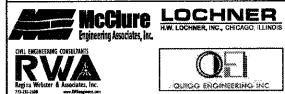

USER NAME = .USERNAME.	DESIGNED - BLM	REVISED -
	DRAWN - JPW	REVISED -
PLOT SCALE = 50.0000' / IN.	CHECKED - BLM	REVISED -
PLOT DATE = 10/19/2011	DATE - 10/14/11	REVISED -

**STATE OF ILLINOIS
DEPARTMENT OF TRANSPORTATION**

**LIGHTING PLAN
OVERHEAD SIGN STRUCTURE**

SCALE:	SHEET NO.	OF	SHEETS	STA.	TO STA.
--------	-----------	----	--------	------	---------

F.A.I. RTE.	SECTION	COUNTY	TOTAL SHEETS	SHEET NO.
90	(X2-1)R	WINNEBAGO	510	275
CONTRACT NO. 64C29				
ILLINOIS FED. AID PROJECT				

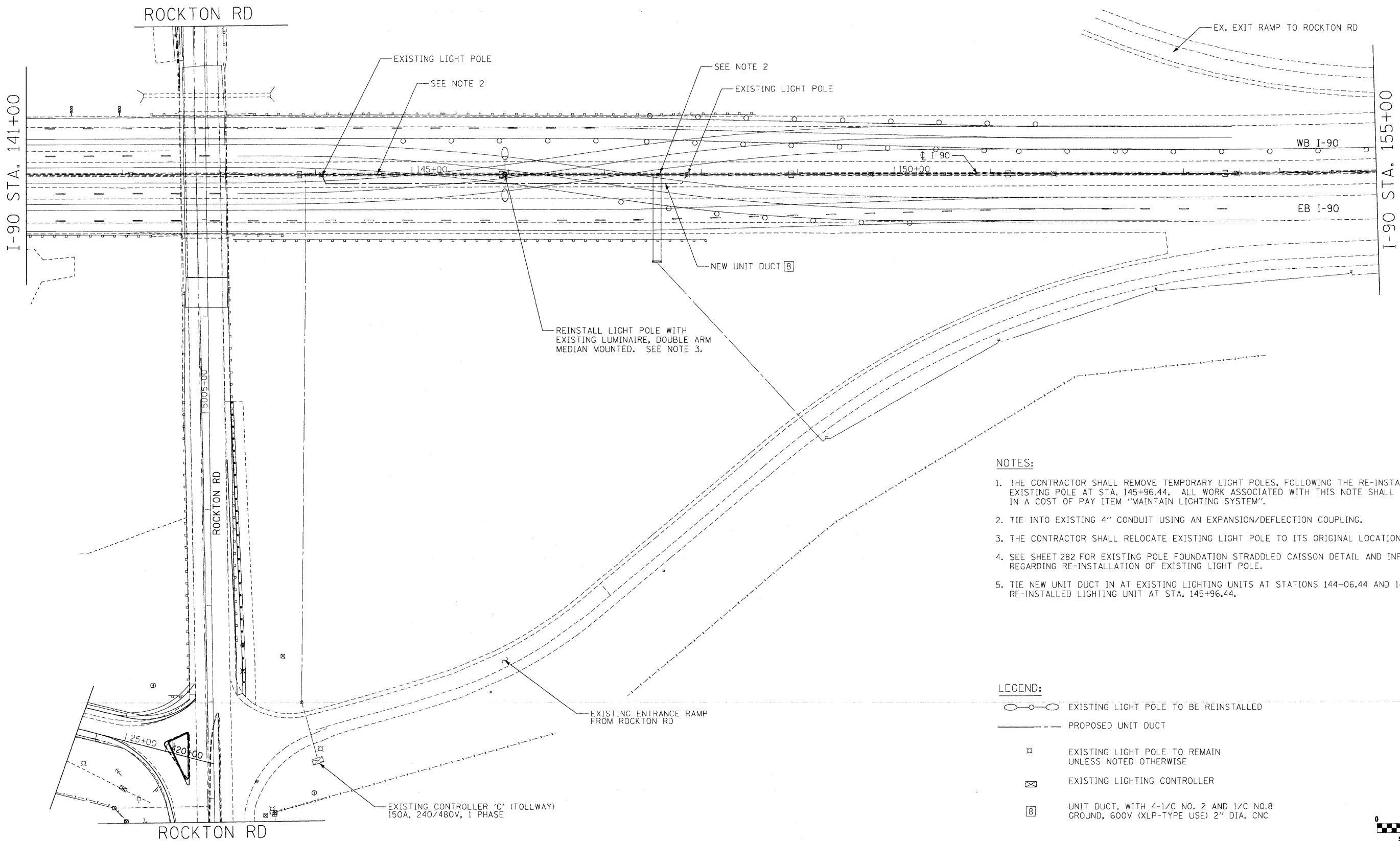

- NOTES:**
1. THE CONTRACTOR SHALL REMOVE TEMPORARY LIGHT POLES, FOLLOWING THE RE-INSTALLATION OF EXISTING POLE AT STA. 145+96.44. ALL WORK ASSOCIATED WITH THIS NOTE SHALL BE INCLUDED IN A COST OF PAY ITEM "MAINTAIN LIGHTING SYSTEM".
 2. TIE INTO EXISTING 4" CONDUIT USING AN EXPANSION/DEFLECTION COUPLING.
 3. THE CONTRACTOR SHALL RELOCATE EXISTING LIGHT POLE TO ITS ORIGINAL LOCATION.
 4. SEE SHEET 282 FOR EXISTING POLE FOUNDATION STRADDLED CAISSON DETAIL AND INFORMATION REGARDING RE-INSTALLATION OF EXISTING LIGHT POLE.
 5. TIE NEW UNIT DUCT IN AT EXISTING LIGHTING UNITS AT STATIONS 144+06.44 AND 147+85.44 AND RE-INSTALLED LIGHTING UNIT AT STA. 145+96.44.

- LEGEND:**
- EXISTING LIGHT POLE TO BE REINSTALLED
 - PROPOSED UNIT DUCT
 - EXISTING LIGHT POLE TO REMAIN UNLESS NOTED OTHERWISE
 - EXISTING LIGHTING CONTROLLER
 - UNIT DUCT, WITH 4-1/2" NO. 2 AND 1/2" NO. 8 GROUND, 600V (XLP-TYPE USE) 2" DIA. CNC

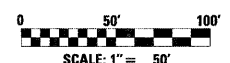

 	USER NAME = .USERNAME.	DESIGNED - BLM	REVISED -
	PLOT SCALE = 50.0000' / IN.	DRAWN - JPW	REVISED -
 	PLOT DATE = 10/19/2011	CHECKED - BLM	REVISED -
		DATE - 10/14/11	REVISED -

**STATE OF ILLINOIS
DEPARTMENT OF TRANSPORTATION**

I-90 LIGHTING PLAN TOLLWAY CROSSOVER			
SCALE:	SHEET NO.	OF SHEETS	STA. TO STA.

F.A.I. RTE. 90	SECTION (X2-1)R	COUNTY WINNEBAGO	TOTAL SHEETS 510	SHEET NO. 276
CONTRACT NO. 64C29			ILLINOIS FED. AID PROJECT	

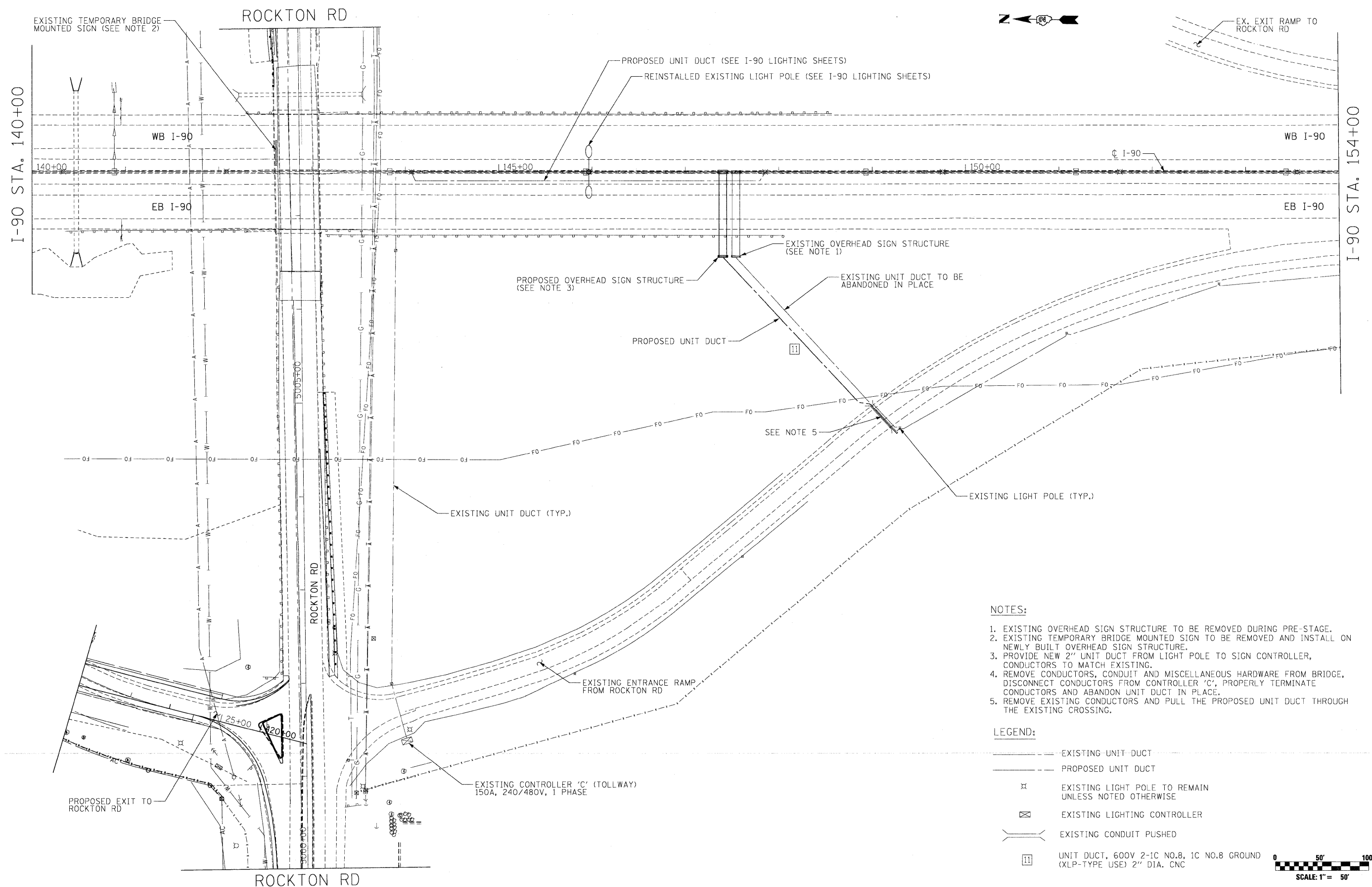

NOTES:

1. EXISTING OVERHEAD SIGN STRUCTURE TO BE REMOVED DURING PRE-STAGE.
2. EXISTING TEMPORARY BRIDGE MOUNTED SIGN TO BE REMOVED AND INSTALL ON NEWLY BUILT OVERHEAD SIGN STRUCTURE.
3. PROVIDE NEW 2" UNIT DUCT FROM LIGHT POLE TO SIGN CONTROLLER, CONDUCTORS TO MATCH EXISTING.
4. REMOVE CONDUCTORS, CONDUIT AND MISCELLANEOUS HARDWARE FROM BRIDGE, DISCONNECT CONDUCTORS FROM CONTROLLER 'C', PROPERLY TERMINATE CONDUCTORS AND ABANDON UNIT DUCT IN PLACE.
5. REMOVE EXISTING CONDUCTORS AND PULL THE PROPOSED UNIT DUCT THROUGH THE EXISTING CROSSING.

LEGEND:

- EXISTING UNIT DUCT
- PROPOSED UNIT DUCT
- ⊗ EXISTING LIGHT POLE TO REMAIN UNLESS NOTED OTHERWISE
- ⊗ EXISTING LIGHTING CONTROLLER
- EXISTING CONDUIT PUSHED
- ⊠ UNIT DUCT, 600V 2-1C NO.8, 1C NO.8 GROUND (XLP-TYPE USE) 2" DIA. CNC

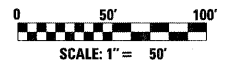

McClure LOCHNER
Engineering Associates, Inc.
RVA
Civil Engineering & Surveying, Inc.

USER NAME = .USERNAME.	DESIGNED - BLM	REVISED -
PLOT SCALE = 50.0000' / IN.	DRAWN - JPW	REVISED -
PLOT DATE = 10/19/2011	CHECKED - BLM	REVISED -
	DATE - 10/14/11	REVISED -

**STATE OF ILLINOIS
DEPARTMENT OF TRANSPORTATION**

LIGHTING PLAN OVERHEAD SIGN STRUCTURE - TOLLWAY				
SCALE:	SHEET NO.	OF	SHEETS	STA. TO STA.

F.A.I. RTE.	SECTION	COUNTY	TOTAL SHEETS	SHEET NO.
90	(X2-1)R	WINNEBAGO	510	277
CONTRACT NO. 64C29				
ILLINOIS FED. AID PROJECT				

F.A.I. RTE.	SECTION	WINNEBAGO	SHEETS NO.	SHEET
90			546	188
STA. 10+271		TO STA. 10+575		
FED. ROAD DIST. NO.		ILLINOIS FED. AID PROJECT		
* X2-11-K, 1HBR, 1HBR-1, 1HBR-2				

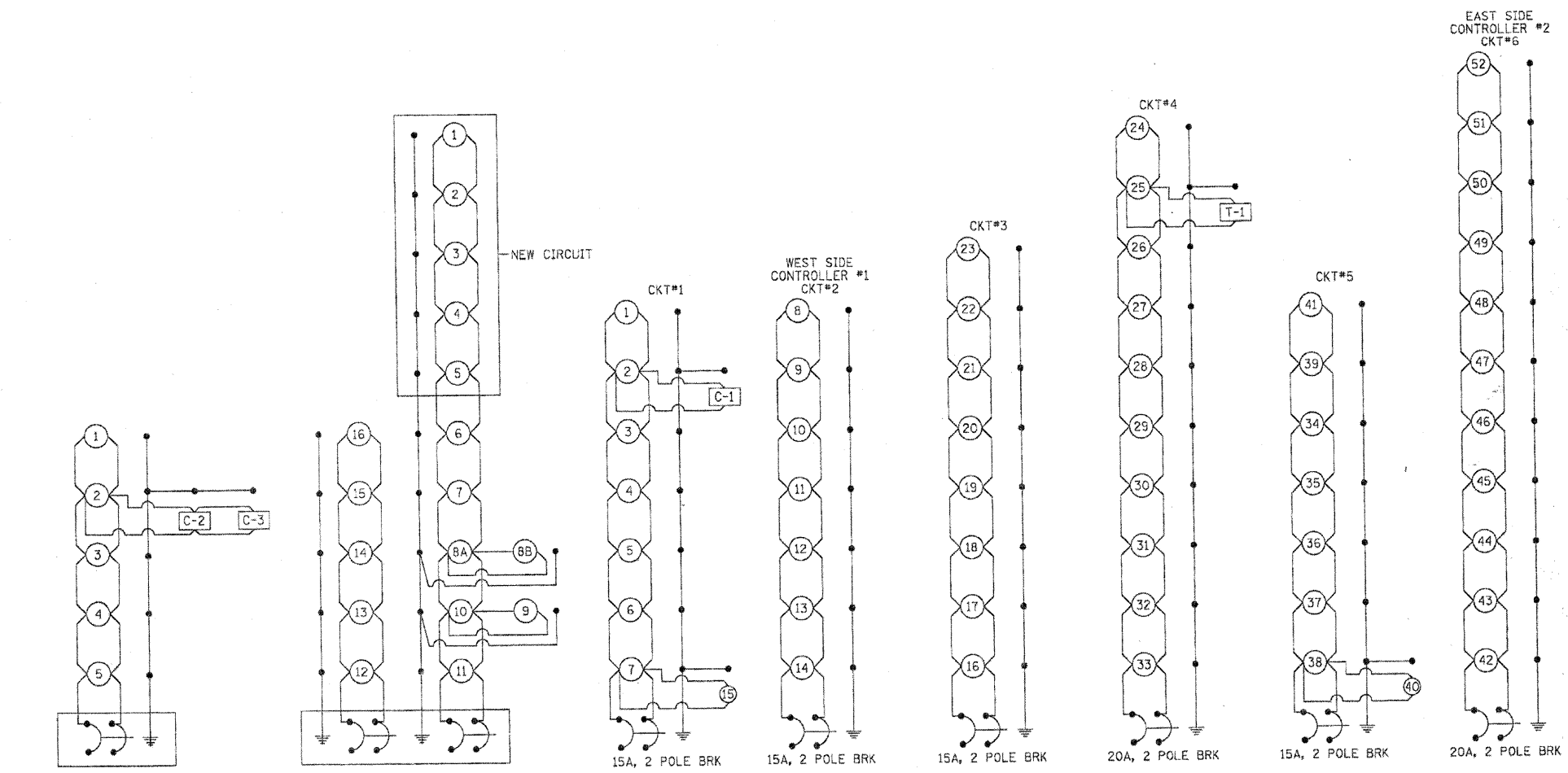

EXISTING CONTROL INSTALLATION
(LOCATED IN VISITORS BUILDING)
* EXISTING CONTROL INSTALLATION
HAS AN EXTRA 50 AMP BREAKER

EXISTING CONTROL INSTALLATION
(LOCATED IN VISITORS BUILDING)

250W, 240V LUMINAIRE

REVISIONS		ILLINOIS DEPARTMENT OF TRANSPORTATION FAI 90 AT FAP 501 (IL 75/US 51) CONTROLLER INSTALLATION DIAGRAMS DRAWN BY SYJ CHECKED BY TGB DATE 4-23-99
NAME	DATE	

FOR INFORMATION ONLY

F.A.I. RTE.	SECTION	COUNTY	TOTAL SHEETS	SHEET NO.
90	*	WINNEBAGO	546	157
STA.	TO STA.			
	ILLINOIS FED. AID PROJECT			
FED. ROAD DIST. NO.	* X2-11-K, 1HBR, 1HBR-1, 1HBR-2)			

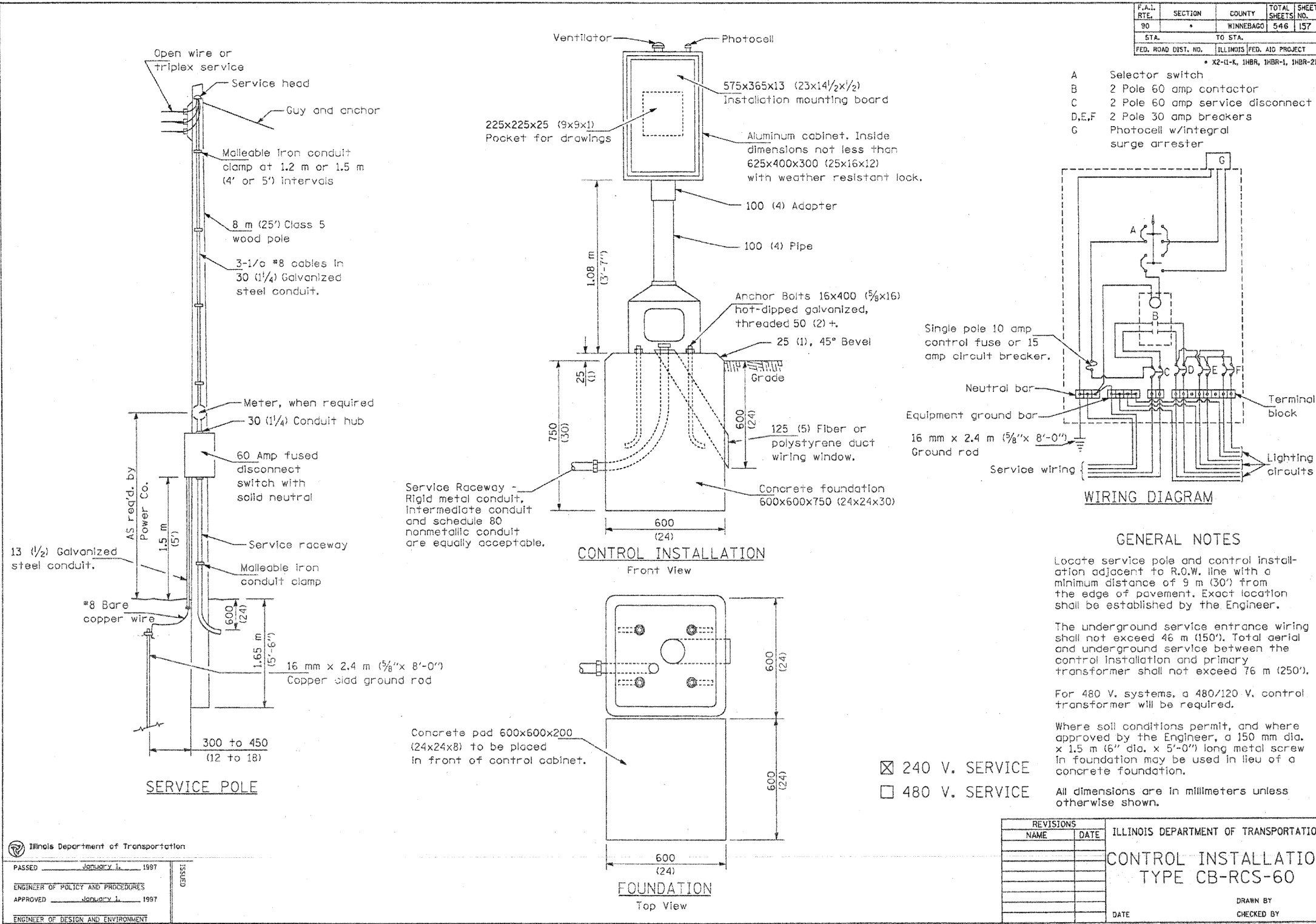

FOR INFORMATION ONLY

F.A.I. RTE.	SECTION	COUNTY	TOTAL SHEET	SHEET NO.
90	(X2-1)HL-1	WINNEBAGO	5	5
STA.	TO STA.			
FED. ROAD DIST. NO.	ILLINOIS FED. AID PROJECT			

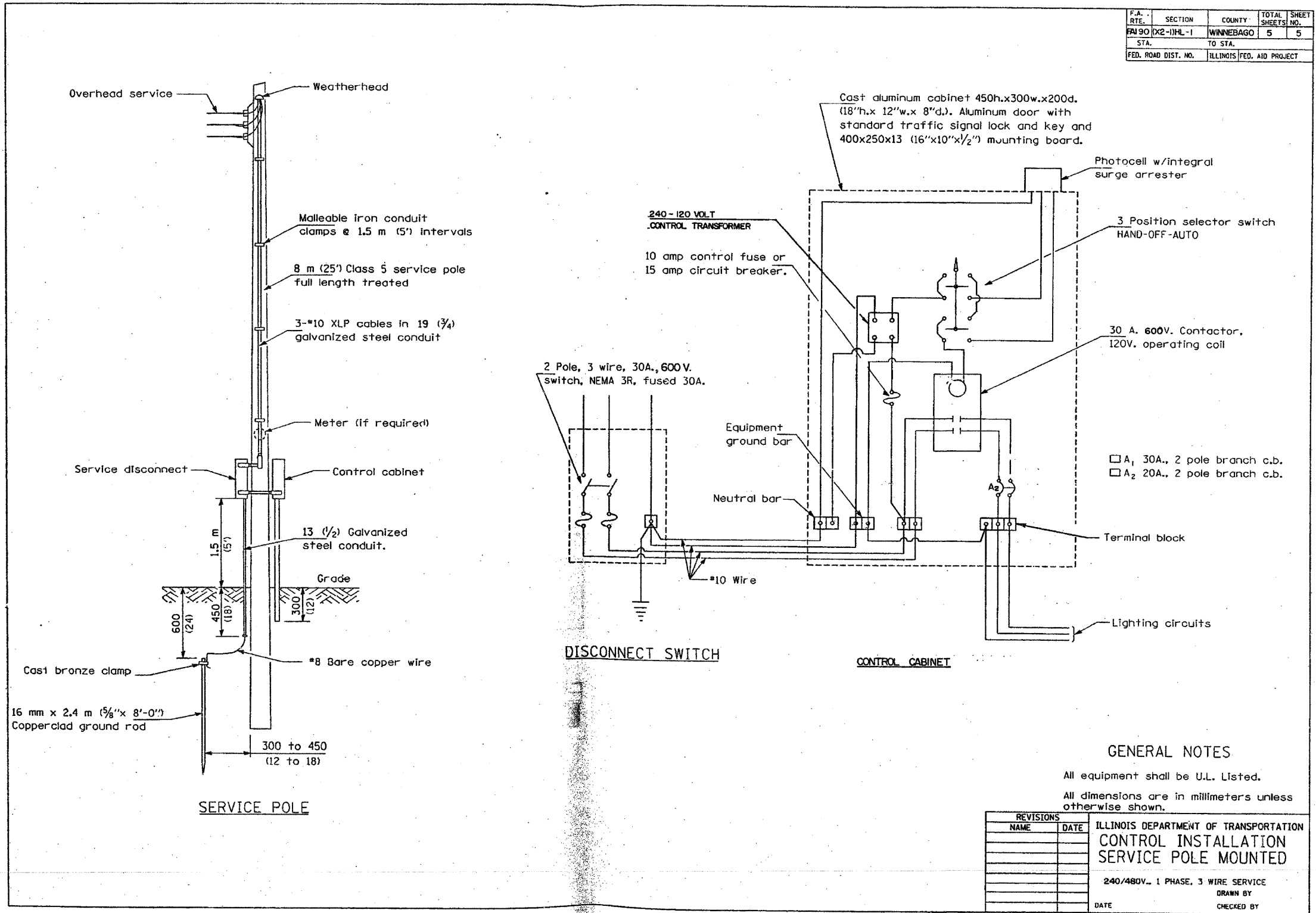

GENERAL NOTES

All equipment shall be U.L. Listed.
 All dimensions are in millimeters unless otherwise shown.

REVISIONS	
NAME	DATE

ILLINOIS DEPARTMENT OF TRANSPORTATION
CONTROL INSTALLATION SERVICE POLE MOUNTED
 240/480V. 1 PHASE, 3 WIRE SERVICE
 DRAWN BY _____
 CHECKED BY _____
 DATE _____

Rev. No. 01/14/11 1898
 Ausr / 09/04/11 / 2127 887 / 04/03/11 LVM-43

FOR INFORMATION ONLY



USER NAME = .USERNAME.	DESIGNED - BLM	REVISED -
	DRAWN - ECS	REVISED -
PLOT SCALE = 10.0000' / IN.	CHECKED - BLM	REVISED -
PLOT DATE = 10/19/2011	DATE - 10/14/11	REVISED -

**STATE OF ILLINOIS
 DEPARTMENT OF TRANSPORTATION**

EXISTING CONTROLLER PLAN			
EB I-90 EXIT RAMP TO ROCKTON ROAD			
SCALE: NTS	SHEET NO.	OF SHEETS	STA. TO STA.

F.A.I. RTE.	SECTION	COUNTY	TOTAL SHEETS	SHEET NO.
90	(X2-1)R	WINNEBAGO	510	280
				CONTRACT NO. 64C29
ILLINOIS FED. AID PROJECT				

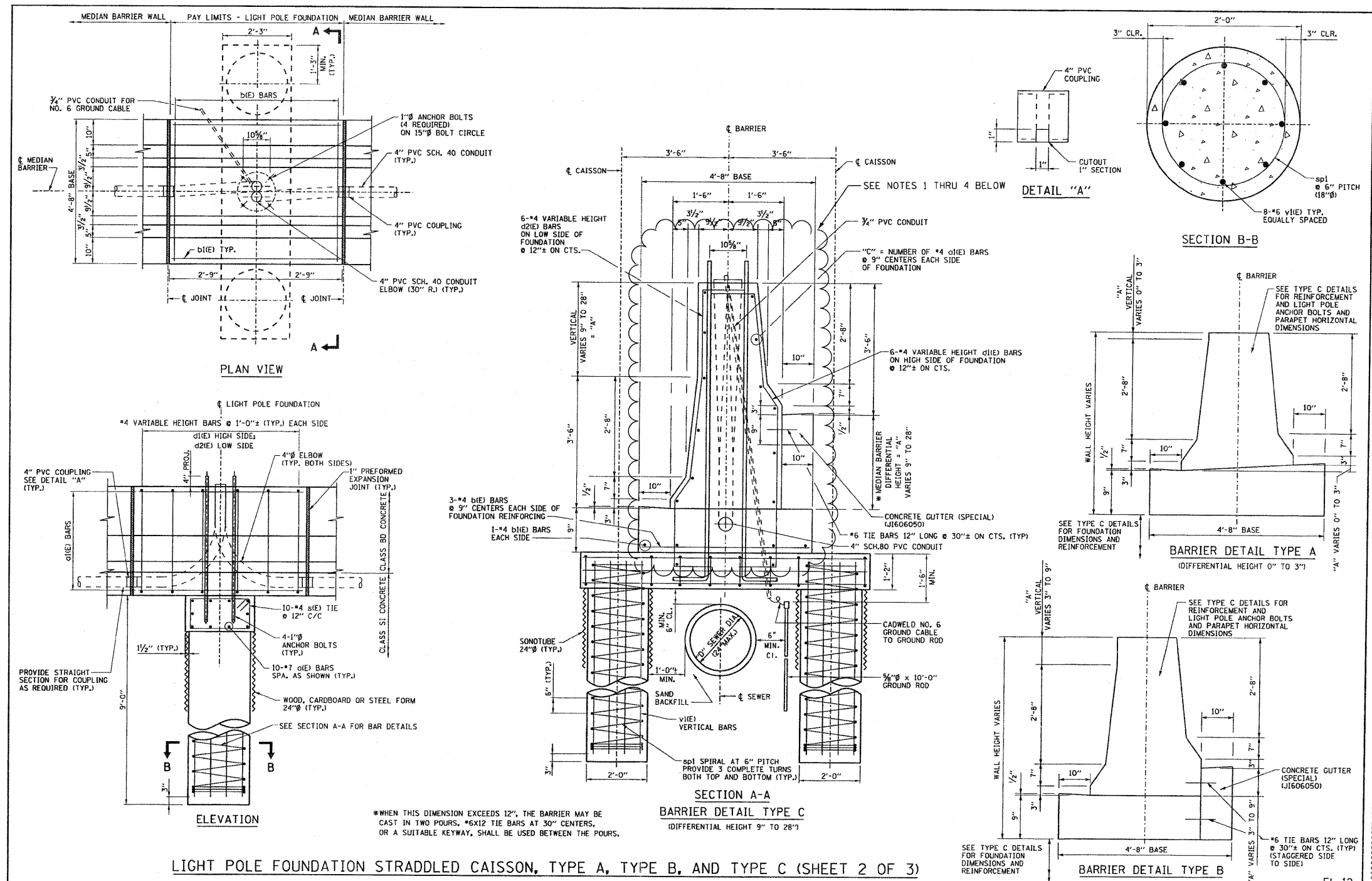

LIGHT POLE FOUNDATION STRADDLED CAISSON, TYPE A, TYPE B, AND TYPE C (SHEET 2 OF 3)

DRAWN BY: DLC DATE: 5/22/08
 CHECKED BY: RDC DATE: 5/22/08

STS | AECOM
 303 East Wacker Drive, Suite 600
 Chicago, Illinois 60601
 Ph: (312) 628-3886
 Fax: (312) 628-3892
 IL Design Firm Reg. No. 184-001518
 www.stsconsultants.com

THE ILLINOIS STATE TOLL HIGHWAY AUTHORITY
 2700 OGDEN AVENUE
 DOWNERS GROVE, ILLINOIS 60515

NO.	DATE	DESCRIPTION

CONTRACT NO. I-08-5544
 VARIABLE HEIGHT MEDIAN BARRIER
 LIGHT POLE FOUNDATION
 STRADDLED CAISSON DETAILS
 DRAWING NO. 139 OF 186

NOTES:

- EXISTING #4 VERTICAL REINFORCEMENTS AND 1 1/2" DIA. ANCHOR BOLTS EMBEDDED IN THE FOOTING SHALL BE PRESERVED AFTER THE EXISTING CONCRETE BARRIER IS REMOVED. PRESERVED REINFORCEMENTS AND ANCHOR BOLTS SHALL BE CUT 6 3/4" (MIN.) ABOVE TOP OF THE FOOTING. THE REMAINING PORTIONS SHALL BE THREADED AND PREPARED TO LAP WITH THE NEW #4 VERTICAL REINFORCEMENTS AND 1 1/2" DIA. ANCHOR BOLTS THROUGH THREADED COUPLERS IN A LATER CONSTRUCTION STAGE. THE MECHANICAL SPLICE CONNECTION MUST HAVE THE STRENGTH TO DEVELOP THE CONNECTED REINFORCEMENT AND ANCHOR BOLTS TO THE FULL CAPACITY WITH ADEQUATE FACTOR OF SAFETY PER MANUFACTURER REQUIREMENTS.
- THE REMAINING THREADED EXISTING REINFORCEMENTS AND ANCHOR BOLTS MUST BE PROTECTED UNDER THE LIVE TRAFFIC DURING THE INTERIM CONSTRUCTION STAGING.
- CONTRACTOR IS RESPONSIBLE TO PROVIDE THE DESIGN AND MATERIALS OF THE NEW REINFORCEMENTS, ANCHOR BOLTS AND CONDUITS AS REQUIRED TO MATCH THE EXISTING CONDITIONS AND MEANWHILE CONFORM TO THE NEW CONCRETE BARRIER WALL GEOMETRIES.
- FINAL DESIGN DETAILS, CALCULATIONS AND RELATED PRODUCT INFORMATION MUST BE SIGNED AND SEALED BY A LICENSED ILLINOIS STRUCTURAL ENGINEER AND SUBMITTED TO THE ENGINEER FOR REVIEW AND APPROVAL PRIOR TO THE COMMENCEMENT OF THE PROJECT.



USER NAME = .USERNAME.	DESIGNED - BLM	REVISED -
PLOT SCALE = 10.0000' / 1" IN.	DRAWN - ECS	REVISED -
PLOT DATE = 10/19/2011	CHECKED - BLM	REVISED -
	DATE - 10/14/11	REVISED -

STATE OF ILLINOIS
 DEPARTMENT OF TRANSPORTATION

TOLLWAY STRADDLED CAISSON LIGHT POLE
 FOUNDATION DETAIL

SCALE: NTS	SHEET NO. OF SHEETS	STA. TO STA.
------------	---------------------	--------------

F.A.I. RTE. 90	SECTION (X2-1)R	COUNTY WINNEBAGO	TOTAL SHEETS 510	SHEET NO. 282
ILLINOIS FED. AID PROJECT			CONTRACT NO. 64C29	

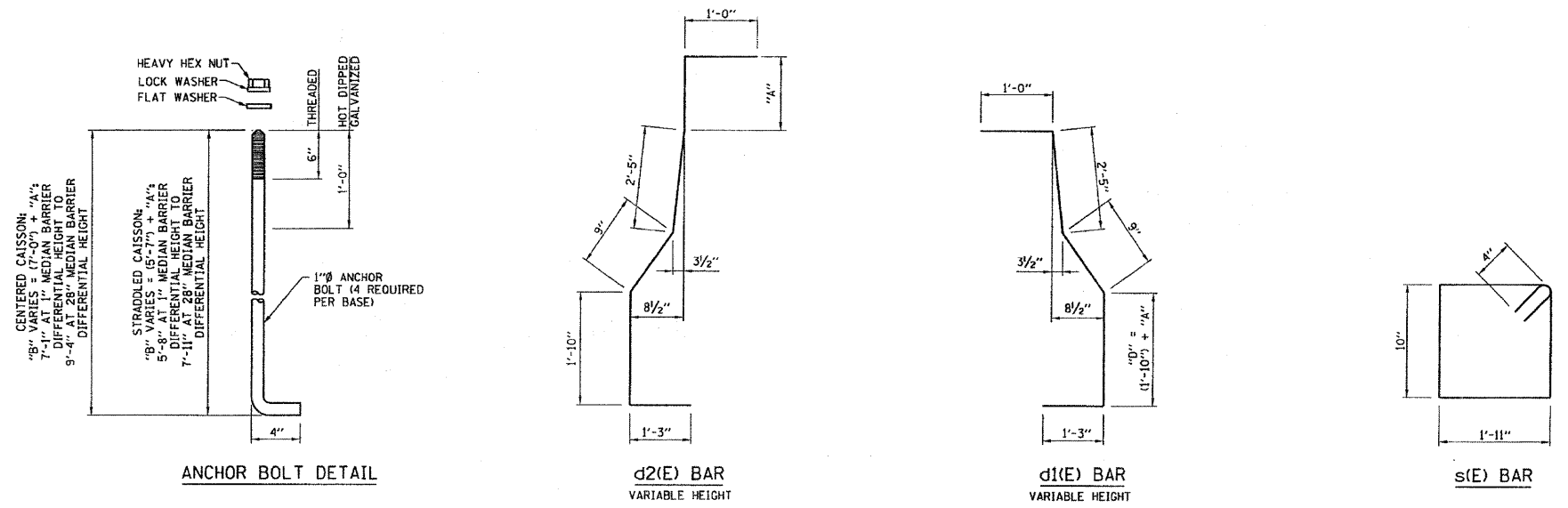

- GENERAL NOTES**
1. THE FORMING OF CONTRACTION JOINTS SHALL BE DONE WITH AN APPROVED FINISHING TOOL AT THE DISCRETION OF THE ENGINEER SUBJECT TO THE SATISFACTORY CONTROL OF CRACKING. THE SAWING OF CONTRACTION JOINTS IN THE CONCRETE BARRIER WALL SHALL NOT BE PERMITTED.
 2. GUTTER PROFILE IN THE VICINITY OF SAG VERTICAL CURVES, ALONG FLAT GRADES AND AT THE MEETING OF PROPOSED AND EXISTING GUTTER, SHALL BE CAREFULLY CONTROLLED AND FIELD ADJUSTED IF NECESSARY TO ENSURE POSITIVE DRAINAGE AND AVOID PONDING.
 3. IN AREAS OF RELATIVELY FLAT LONGITUDINAL PROFILE GRADES, THE 3" VERTICAL DIMENSION AT THE BOTTOM OF THE BARRIER CAN VARY FROM 2" TO 3 1/4" TO CREATE AN ACCEPTABLE LONGITUDINAL GRADE IN THE GUTTER.
 4. TIE BARS ARE INCIDENTAL TO THE VARIOUS BARRIER & GUTTER ITEMS.
 5. REINFORCEMENT BARS SHALL BE EPOXY COATED.

BAR LAPS
 *4 - 1'-8"

SEE NOTE BELOW

VARIABLE HEIGHT MEDIAN BARRIER LIGHT POLE FOUNDATION SCHEDULE

STATION	LIGHT POLE FOUNDATION TYPE	DIFFERENTIAL HEIGHT "A" FEET	BARRIER TYPE	DIMENSIONS		
				"B" FEET-INCHES	"C" NO.	"D" FEET-INCHES
98+90.00	STRADDLED CAISSON	0.12	A	5'-8"	7	1'-11"
100+73.00	STRADDLED CAISSON	0.10	A	5'-8"	7	1'-11"
102+53.00	CENTERED CAISSON	0.08	A	7'-1"	7	1'-11"
104+28.00	CENTERED CAISSON	0.05	A	7'-0"	7	1'-10"
106+03.00	CENTERED CAISSON	0.05	A	7'-0"	7	1'-10"
108+01.00	STRADDLED CAISSON	0.09	A	5'-8"	7	1'-11"
109+91.00	STRADDLED CAISSON	0.18	A	5'-9"	7	2'-0"
111+80.00	CENTERED CAISSON	0.27	B	6'-3"	8	2'-4"
113+70.00	STRADDLED CAISSON	0.56	B	6'-1"	8	2'-4"
115+60.00	STRADDLED CAISSON	1.11	C	6'-8"	8	2'-11"
117+50.00	STRADDLED CAISSON	1.27	C	6'-10"	9	3'-1"
119+40.00	STRADDLED CAISSON	1.10	C	6'-8"	8	2'-11"
121+30.00	STRADDLED CAISSON	0.91	C	6'-6"	8	2'-9"
123+20.00	STRADDLED CAISSON	0.88	C	6'-5"	8	2'-8"
125+10.00	CENTERED CAISSON	0.98	C	8'-0"	8	2'-10"
127+00.00	CENTERED CAISSON	1.18	C	8'-2"	8	3'-0"
128+90.00	STRADDLED CAISSON	1.20	C	6'-9"	8	3'-0"
130+80.00	STRADDLED CAISSON	1.47	C	7'-0"	9	3'-3"
132+70.00	STRADDLED CAISSON	1.10	C	6'-8"	8	2'-11"
134+55.00	STRADDLED CAISSON	0.51	B	6'-1"	8	2'-4"
136+41.00	STRADDLED CAISSON	0.34	B	6'-2"	8	2'-5"

CENTERED CAISSON

REINFORCING BAR SCHEDULE FOUNDATION					
BAR	NO.	SIZE	LENGTH	WT. LBS.	SHAPE
d1(E)	14 TO 20	#4	5'-0"	47 TO 67	—
b1(E)	6	#4	4'-2"	17	—
b1(E)	2	#4	5'-2"	7	—
d1(E)	6	#4	VARIES 7'-4" TO 9'-7"	29 TO 38	—
d2(E)	6	#4	VARIES 7'-4" TO 9'-7"	29 TO 38	—
sp1	*	#4	*	*	—
v1(E)	8	#6	11'-9"	142	—

* SEE SECT. A-A SHEET EL-10

STRADDLED CAISSON

REINFORCING BAR SCHEDULE FOUNDATION					
BAR	NO.	SIZE	LENGTH	WT. LBS.	SHAPE
d1(E)	10	#7	9'-0"	184	—
d1(E)	14 TO 20	#4	5'-0"	47 TO 67	—
b1(E)	6	#4	4'-2"	17	—
b1(E)	2	#4	5'-2"	7	—
d1(E)	6	#4	VARIES 7'-4" TO 9'-7"	29 TO 38	—
d2(E)	6	#4	VARIES 7'-4" TO 9'-7"	29 TO 38	—
s1(E)	10	#4	6'-2"	42	—
sp1	*	#4	*	*	—
v1(E)	16	#6	9'-9"	235	—

* SEE SECT. A-A SHEET EL-11

"A" VARIES 0" TO 28"
 STRADDLED CAISSON: "B" = "A" + (5'-7")
 CENTERED CAISSON: "B" = "A" + (7'-0")
 "C" = 7 PER SIDE @ "A" = 0'; 10 @ "A" = 28"
 "D" = "A" + (1'-10")

LIGHT POLE FOUNDATIONS (SHEET 3 OF 3)

DRAWN BY: DLC DATE: 5/22/08
 CHECKED BY: RDC DATE: 5/22/08

STS | AECOM

303 East Wacker Drive, Suite 600
 Chicago, Illinois 60601
 PH: (312) 628-3896
 FAX: (312) 628-3892
 IL Design Firm Reg. No. 184-001518
 www.stsconsultants.com



THE ILLINOIS STATE TOLL HIGHWAY AUTHORITY
 2700 OGDEN AVENUE
 DOWNERS GROVE, ILLINOIS 60515

REVISIONS		
NO.	DATE	DESCRIPTION

CONTRACT NO. I-08-5544
 VARIABLE HEIGHT BARRIER LIGHT POLE FOUNDATION DETAILS

DRAWING NO. 140 OF 186

NOTE:
 STRADDLED FOUNDATION AT STA. 109+91.00 (RECORD PLANS) = STA. 145+96.44 (THIS CONTRACT NO. 64C29)

FOR INFORMATION ONLY

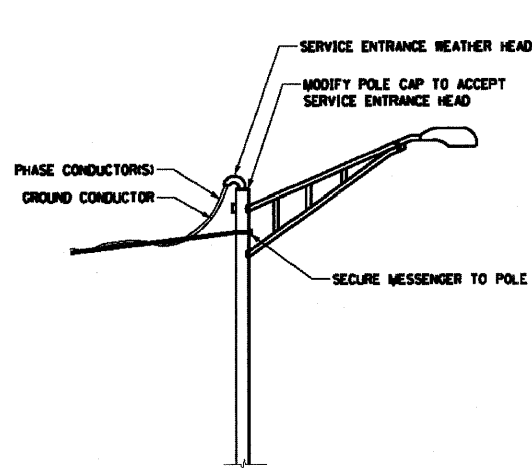

DETAIL 1 □
**TEMPORARY POWER FEED
 TO ALUMINUM POLE**
 NOT TO SCALE

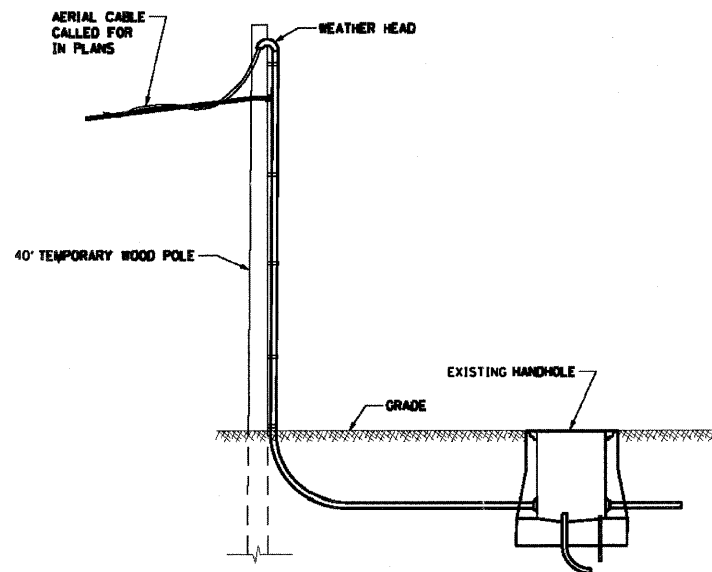

DETAIL 2 ☒
**PROPOSED TEMPORARY POLE/
 HAND HOLE CONNECTION**
 NOT TO SCALE

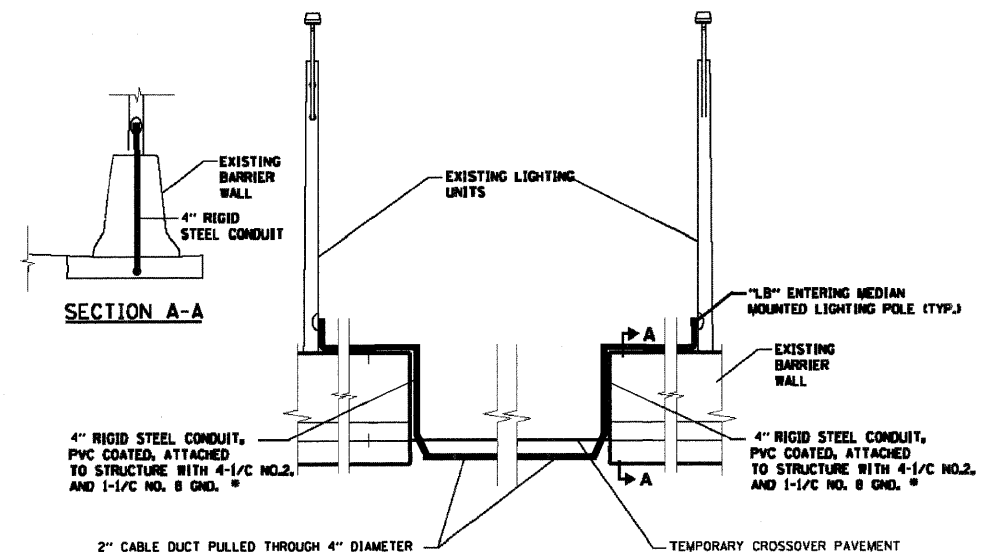

DETAIL 5 ☒
**PROPOSED TEMPORARY CABLE DUCT
 CONNECTION AT
 TEMPORARY CROSSOVER**
 * INCLUDED IN THE COST OF
 "MAINTAIN LIGHTING SYSTEM"

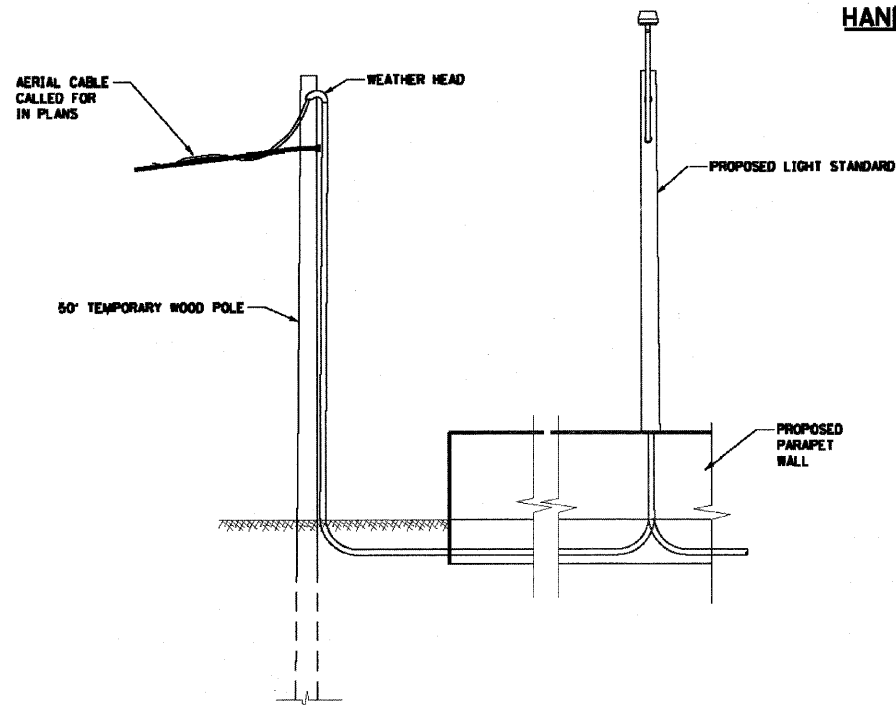

DETAIL 3 □
**PROPOSED TEMPORARY POLE CONNECTION
 TO BARRIER WALL**
 NOT TO SCALE

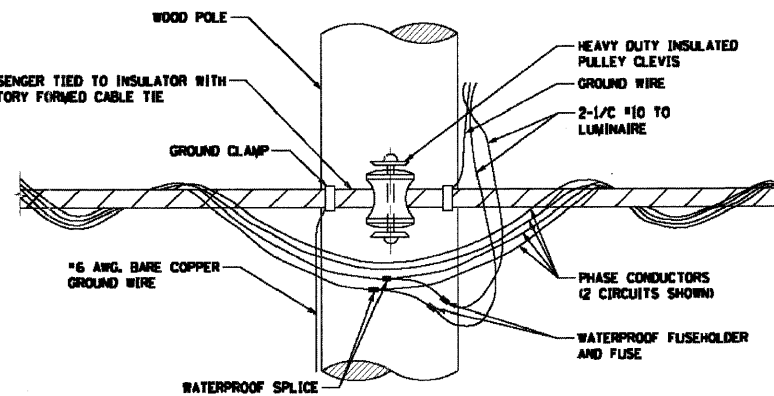

DETAIL 4 ☒
**TEMPORARY LIGHT POLE
 CABLE ATTACHMENT DETAIL**
 NOT TO SCALE
 FOR TEMPORARY CABLE AND ATTACHMENT

- 4-1/2" #2 CONDUCTORS WITH STEEL MESSENGERS FOR GROUNDING CONDUCTOR
- 2-PHASE CONDUCTORS WITH WATER PROOF FUSE HOLDER AND FUSE PER CIRCUIT

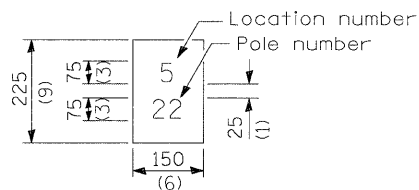

The contractor shall furnish and install a light pole identification of each new light pole, as shown above, incidental to the respective light pole pay item. The numerals shall be 75 (3) series "D", black, screened on silver-white type B pressure sensitive reflective sheeting conforming to the requirements of section T602.01 of the Standard Specifications for Traffic Control Items. The numerals shall conform to the FHWA "Standard Alphabets for Highway Signs".

The light pole identification shall be applied to sign base material as specified in section 1069.06 of the Standard Specifications, approximately 180 (7) above the adjacent pavement grade visible to approaching traffic in accordance with Highway Standard 720001.

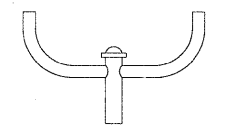

TWIN TENON

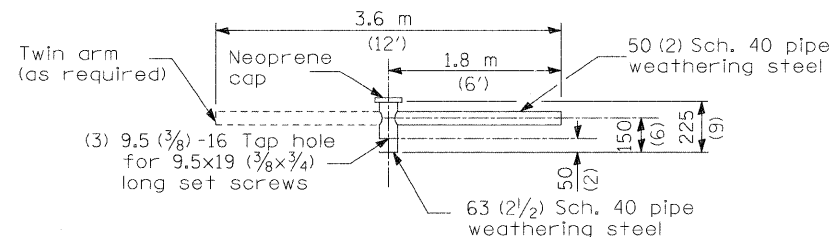

TENON MOUNT BRACKET ARM

NOTE: Single or twin arm assembly shall be tilted 3° above horizontal.

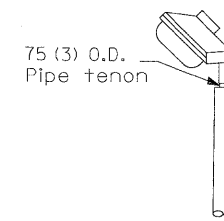

TENON

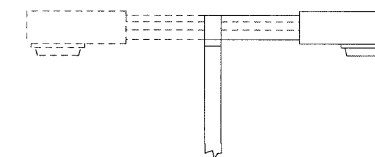

SHORT BRACKET

SHORT BRACKET - TWIN

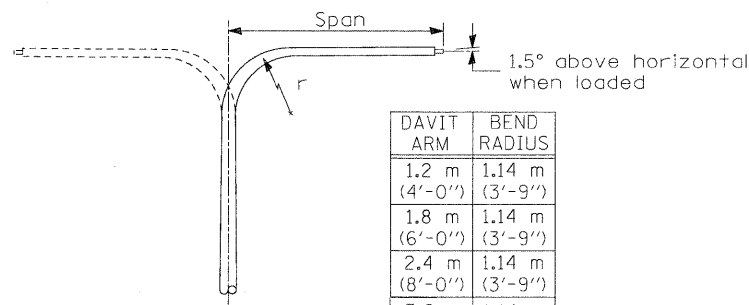

DAVIT ARM

DAVIT ARM-TWIN

DAVIT ARM	BEND RADIUS
1.2 m (4'-0")	1.14 m (3'-9")
1.8 m (6'-0")	1.14 m (3'-9")
2.4 m (8'-0")	1.14 m (3'-9")
3.6 m (12'-0")	1.14 m (3'-9")

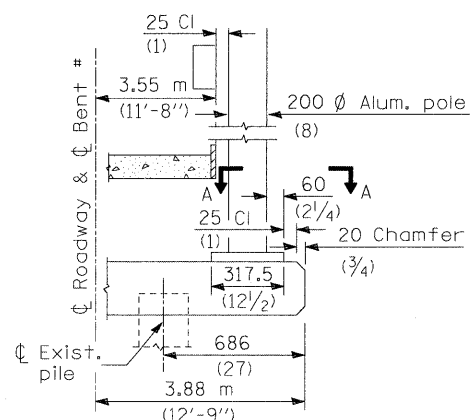

BRIDGE PIER MOUNT

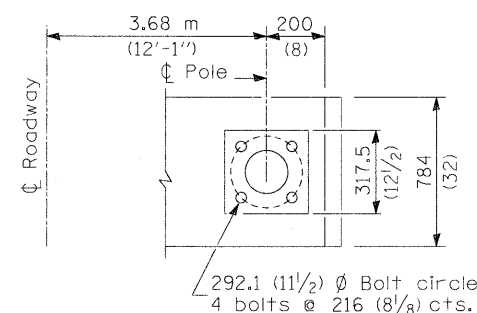
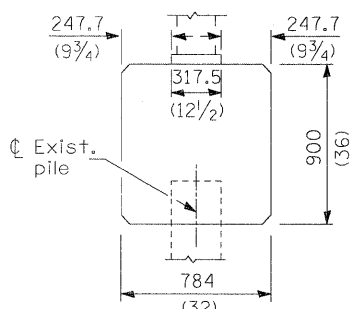

SECTION A-A

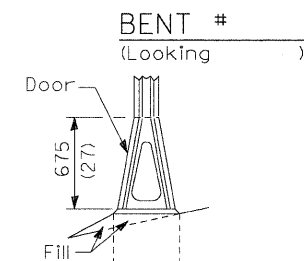

STAINLESS STEEL FLAIR BASE

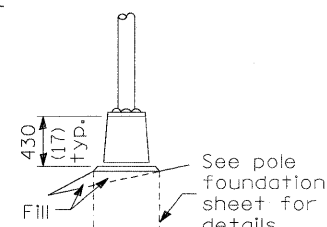

TRANSFORMER BASE

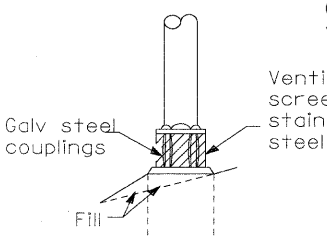

BREAKAWAY COUPLING

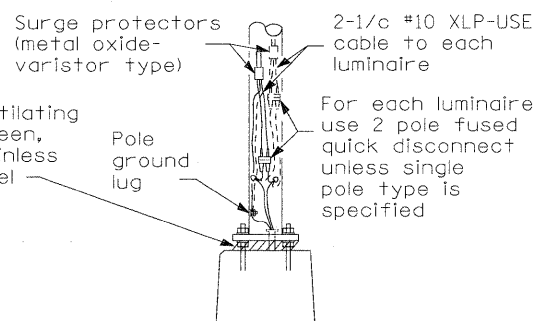

ANCHOR

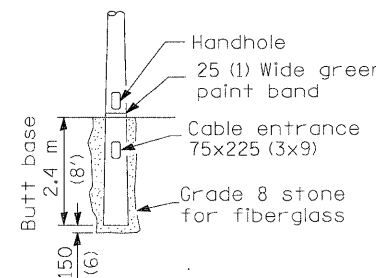

BUTT BASE

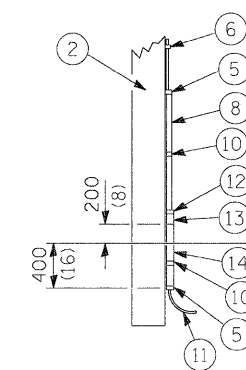

POLE, WOOD

POLE LENGTH	DEPTH IN GROUND
19.8 m (65')	3.6 m (12')
18.0 m (60')	3.0 m (10')
16.8 m (55')	2.7 m (9')
16.0 m (50')	2.4 m (8')
13.7 m (45')	2.1 m (7')
12.0 m (40')	2.0 m (6.5')
10.7 m (35')	1.8 m (6')
9.0 m (30')	1.7 m (5.5')

All dimensions are in millimeters (inches) unless otherwise shown.

- ① Luminaire
- ② Wood pole, class 3 or better
- ③ 63 (2 1/2) Galv. steel conduit
- ④ Single offset pole band
- ⑤ Conduit bushing
- ⑥ Cable clamps on 600 (24) centers
- ⑦ 2/c #12 Type use cable
- ⑧ 25 (1) Galv. steel conduit 3.0 m (10') in length
- ⑨ 16 (5/8) Ø hot dipped galvanized bolt with flat washer & locknut (3 req'd)
- ⑩ Conduit clamps on 900 (36) centers
- ⑪ Unit duct
- ⑫ Threaded reducer
- ⑬ "C" Condulet, threaded
- ⑭ 40 (1 1/2) Galv. steel conduit for 1 unit duct or 75 (3) galv. steel conduit for 2 or 3 unit ducts.

DRAFT COPY
not for distribution

FRANGIBLE

METAL OR CONCRETE

Details for underground distribution if required

DATE	REVISIONS
	Corrected 6/24/09

POLE STANDARDS

DRAFT

LGT008.M32

Stainless steel standard grade wire cloth,
6x6 (1/4") mesh or less with #16 gauge
(0.062") diameter or heavier wire.

Attach with 1/2" stainless steel banding
or tie back on itself with stainless steel wire ties.
Finished installation must prevent rodent entry.

Surge protectors
(metal oxide-
varistor type)

2-1/c #10 XLP-USE
cable to each
luminaire

Cable splices according
to Art 1066.06 with
compression connectors
appropriately taped.

For each luminaire
use 2 pole fused
quick disconnect.
For receptacle
circuit (not shown)
use 2 pole
fuseholder with
solid neutral.

Pole base plate

1" leveling nuts

Pole
ground
lug

Wireway window
in pole foundation

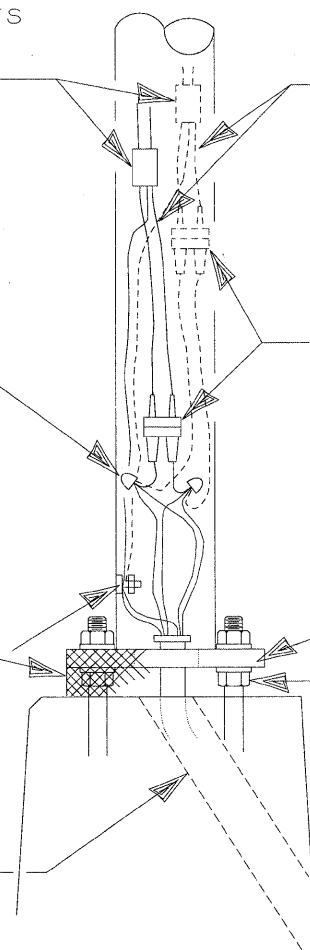

WIRING DETAIL

NO SCALE

GENERAL NOTES

All taped splices shall use 2 layers of electrical tape
over 3 layers of rubber tape as required by the
Standard Specifications. Coat the finished taped
splice with bonding compound.

All cable splices shall be taped unless another method
has been specifically approved by the Engineer.

For example purposes the pole is shown on an anchor base.
If the pole is required to be set on a breakaway base,
consult the Standard Specifications.

All dimensions are in millimeters (inches)
unless otherwise shown.

DRAFT COPY
not for distribution

DATE	REVISIONS
7/31/08	Updated

POLE HANDHOLE WIRING

DRAFT

LGTO08A.DGN

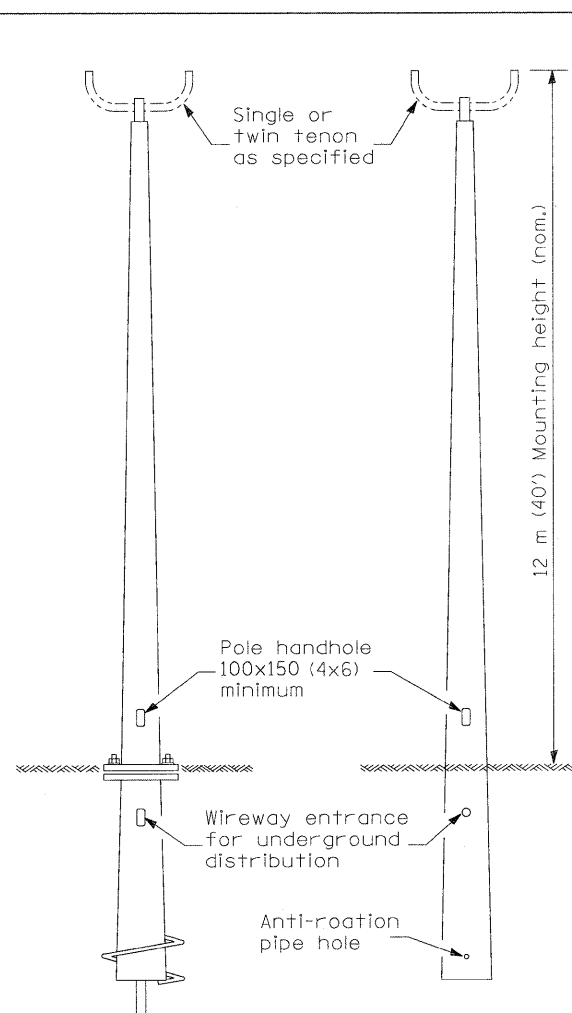

ANCHOR BASE W/
METAL FOUNDATION BUTT BASE
POLE, FIBERGLASS
BREAKAWAY TYPE

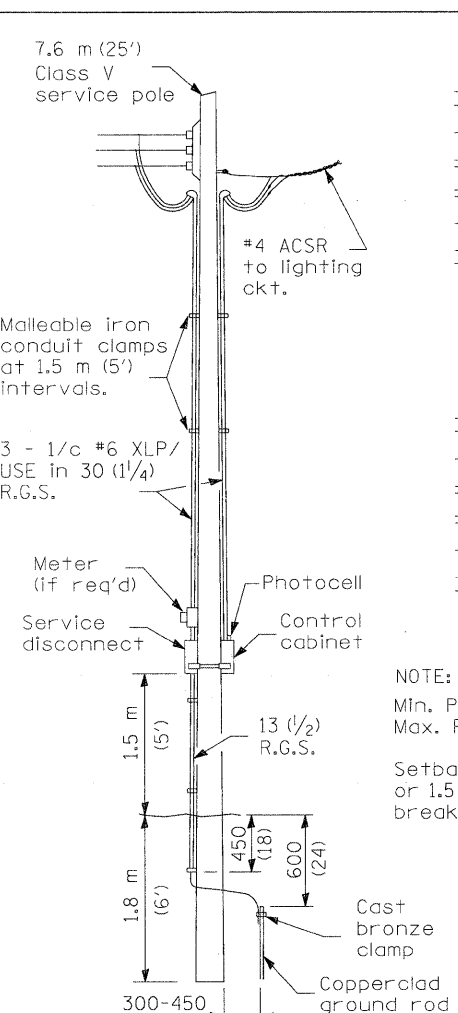

SERVICE
INSTALLATION

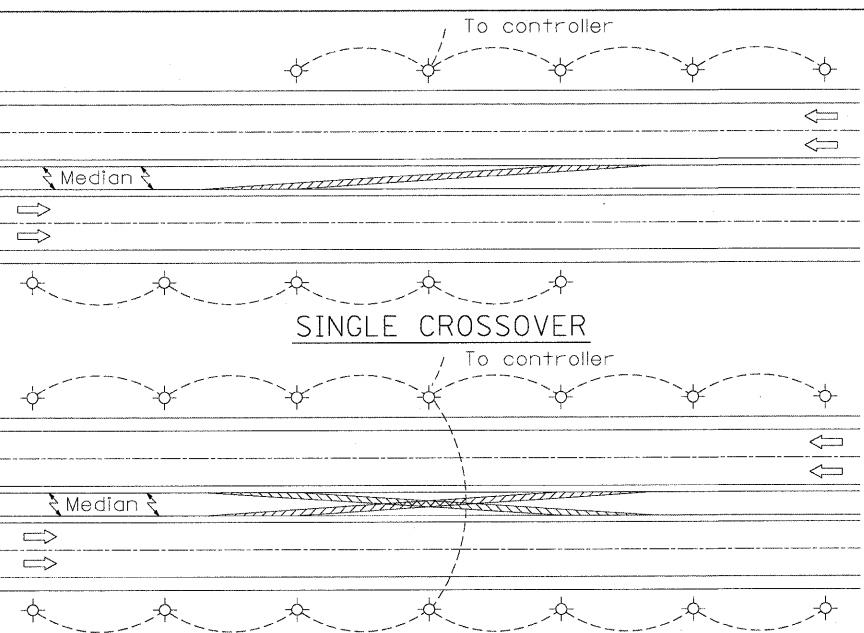

NOTE:
Min. Pole spacing 60 m (200')
Max. Pole spacing 75 m (250')
Setback shall be min. 9 m (30')
or 1.5 m (5') back of ditch, unless
breakaway type pole is used.

- ① Luminaire
- ② Wood pole, class 3 or better
- ③ 63 (2 1/2) Galv. steel conduit
- ④ Single offset pole band
- ⑤ Conduit bushing
- ⑥ Cable clamps on 600 (24) centers
- ⑦ 2/c #12 Type USE cable
- ⑧ 25 (1) Galv. steel conduit 3.0 m (10') in length

NOTE:
Luminaire(s) shall have a 2-pole inline weatherproof quick disconnect fuse holder.
Luminaire(s) shall be oriented and the mounting angle adjusted as recommended by the Engineer.
Connect luminaire equipment ground to ACSR messenger.

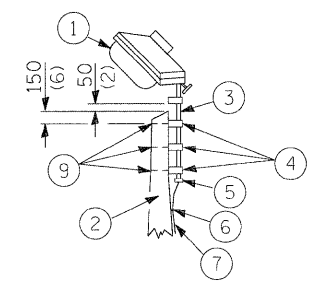

- ⑨ 16 (5/8) Ø hot dipped galvanized bolt with flat washer & locknut (3 req'd)
- ⑩ Conduit clamps on 900 (36) centers
- ⑪ Unit duct
- ⑫ Threaded reducer
- ⑬ "C" Condulet, threaded
- ⑭ 40 (1 1/2) Galv. steel conduit for 1 unit duct or 75 (3) galv. steel conduit for 2 or 3 unit ducts.

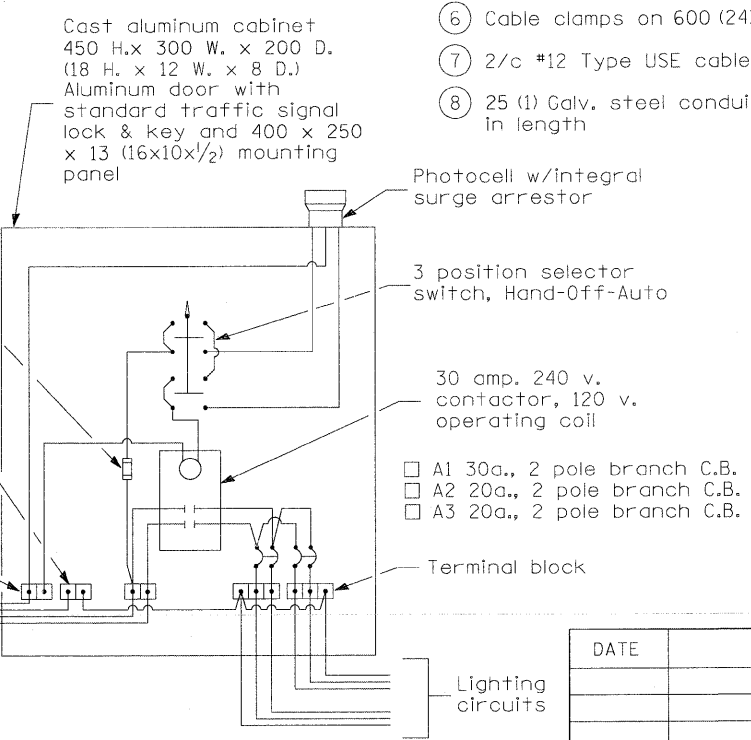

WIRING DIAGRAM

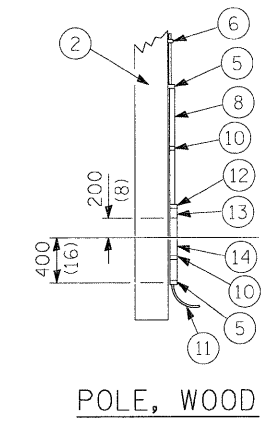

POLE, WOOD

POLE LENGTH	DEPTH IN GROUND
19.8 m (65')	3.6 m (12')
18.0 m (60')	3.0 m (10')
16.8 m (55')	2.7 m (9')
16.0 m (50')	2.4 m (8')
13.7 m (45')	2.1 m (7')
12.0 m (40')	2.0 m (6.5')
10.7 m (35')	1.8 m (6')
9.0 m (30')	1.7 m (5.5')

All dimensions are in millimeters (inches) unless otherwise shown.

DATE	REVISIONS

TEMPORARY ROADWAY LIGHTING

LGT014.M32

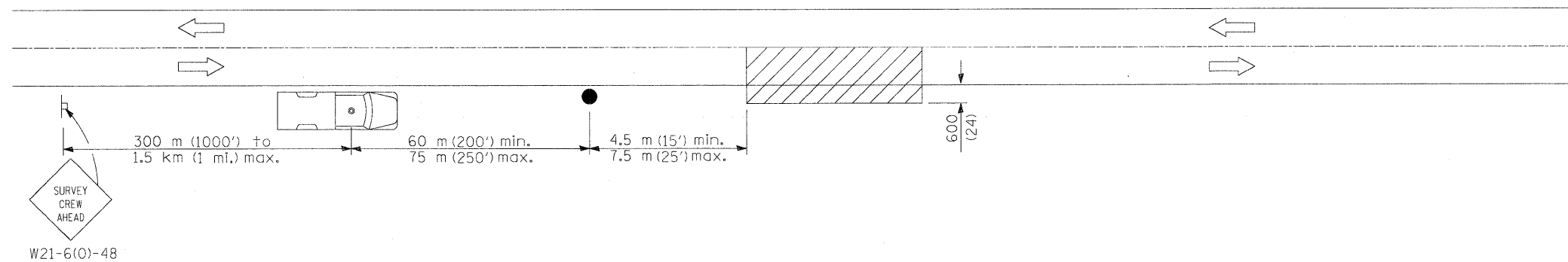

W21-6(0)-48

SYMBOLS



Work area



Sign on portable or permanent support

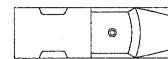

Truck with flashing amber light and dual emergency flashers



Flagger with traffic control sign

TYPICAL APPLICATIONS
Utility operations

All dimensions are in millimeters (inches) unless otherwise shown.

DATE	REVISIONS

DETAIL FOR
NIGHTTIME LIGHTING
INSPECTION

LGT017.M32

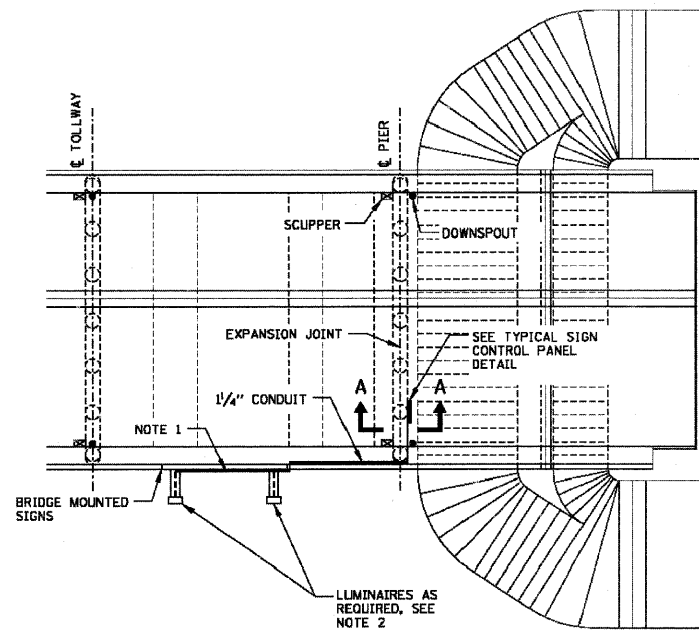

PLAN

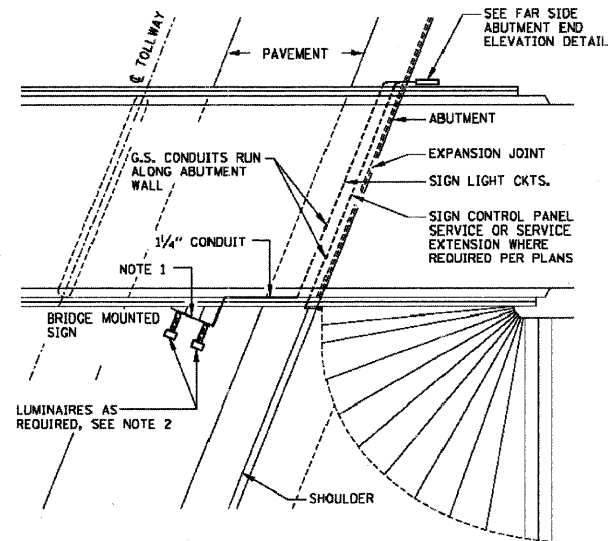

PLAN

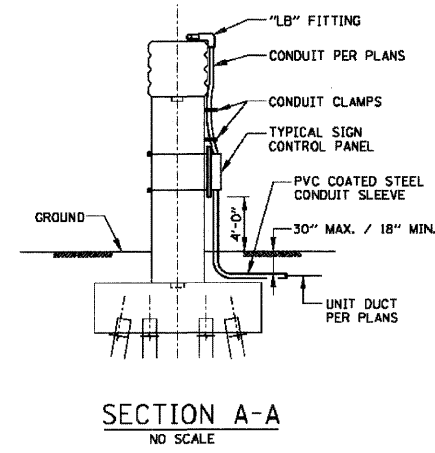

SECTION A-A
NO SCALE

NOTES:

1. FOR SIGN STRUCTURE INSTALLATION DETAILS, SEE SHEET 2 (OF 2) IN THIS SERIES.
2. FOR SIGN LUMINAIRE INSTALLATION AND WIRING, SEE STANDARD H14 (SIGN LUMINAIRE MOUNTING DETAIL AND WIRING DIAGRAMS).

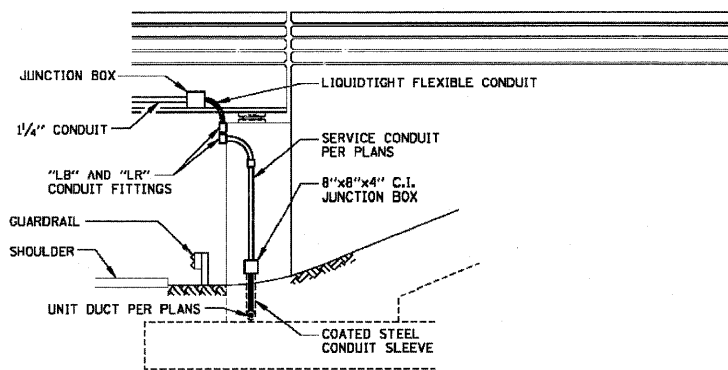

NEAR SIDE ABUTMENT END ELEVATION
NO SCALE

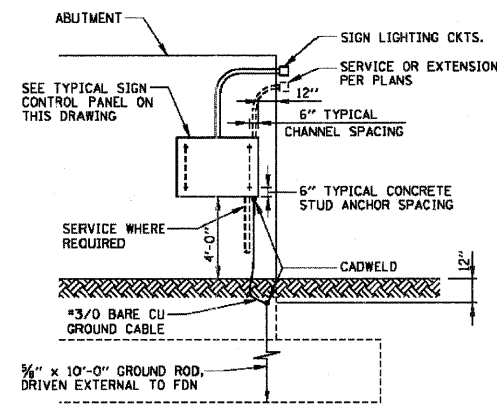

FAR SIDE ABUTMENT END ELEVATION
NO SCALE

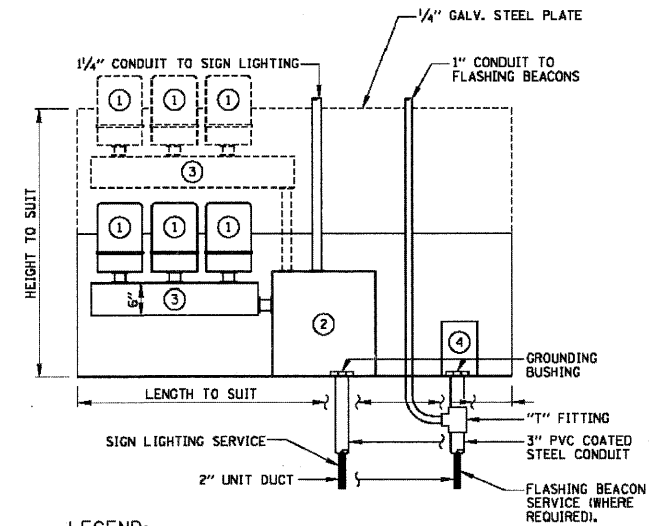

LEGEND:

- 1 WEATHERPROOF CANNISTER BALLAST (BALLAST SHALL BE MARKED TO IDENTIFY WHICH LUMINAIRE IT IS WIRED).
- 2 SIGN LIGHTING SERVICE - CIRCUIT BREAKER (30 AMP/2 POLE) IN NEMA TYPE 4 C.I. ENCLOSURE, OZ TYPE "YW" WITH MOUNTING FEET OR APPROVED EQUAL.
- 3 6"x6" HOT DIPPED GALVANIZED WEATHERPROOF WIREWAY (LENGTH TO SUIT).
- 4 FLASHING BEACON CONTROLLER.

TYPICAL SIGN CONTROL PANEL

FOR TYPICAL WIRING DIAGRAM SEE STANDARD H14 (SIGN LUMINAIRE MOUNTING DETAIL AND WIRING DIAGRAMS)
NO SCALE

SHEET 1 OF 2



APPROVED: *Jeff Daly* DATE 1-1-2007

DATE	REVISIONS

BRIDGE MOUNT SIGN LIGHTING TYPICAL WIRING
STANDARD H10-00

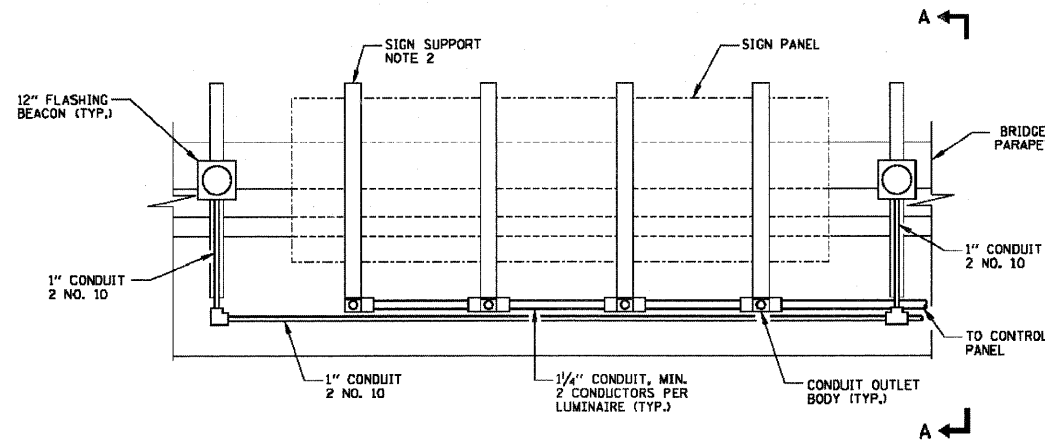

TYPICAL FRONT ELEVATION WITH FLASHING BEACON

LUMINAIRES NOT SHOWN
NO SCALE

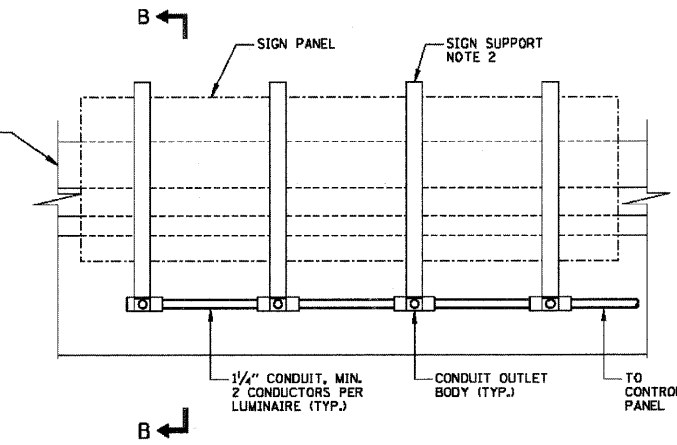

TYPICAL FRONT ELEVATION WITHOUT FLASHING BEACON

LUMINAIRES NOT SHOWN
NO SCALE

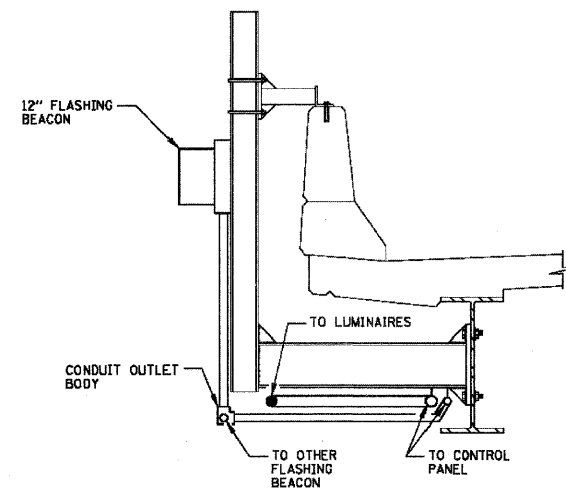

SECTION A-A
STEEL BRIDGE SHOWN
NO SCALE

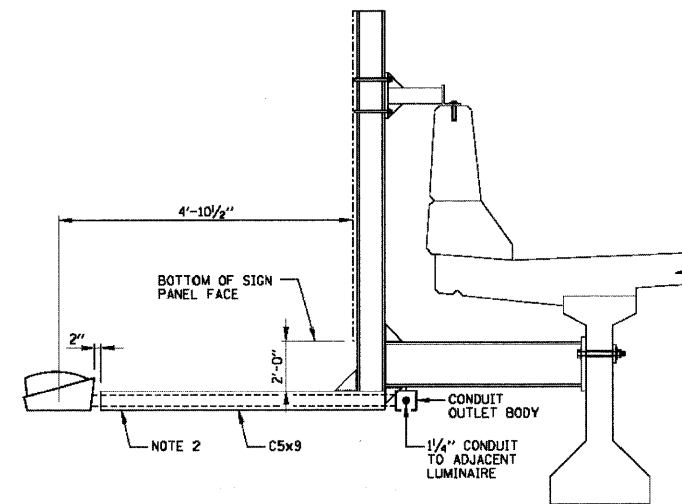

SECTION B-B
CONCRETE BRIDGE SHOWN
NO SCALE

NOTES:

1. PROVIDE 12" FLASHING BEACON ONLY WHERE INDICATED ON PLANS.
2. SEE STRUCTURAL DRAWINGS FOR DETAILS OF SIGN SUPPORTS AND FIXTURE SUPPORT CHANNELS.
3. SEE STANDARD H14 (SIGN LUMINAIRE MOUNTING DETAIL AND WIRING DIAGRAMS) FOR INSTALLATION OF CONDUIT IN FIXTURE SUPPORT CHANNEL.
4. FLASHING BEACON TO BE ATTACHED TO SUPPORT WITH STAINLESS STEEL SCREWS AND NEOPRENE SPACERS. DRILLED SCREW HOLES TO BE SEALED WATERTIGHT.

SHEET 2 OF 2



DATE	REVISIONS

BRIDGE MOUNT SIGN
LIGHTING TYPICAL WIRING

STANDARD H10-00

APPROVED: *Jeff Staley*
CHIEF ENGINEER DATE 1-1-2007



USER NAME = .USERNAME.	DESIGNED - AM	REVISED -
PLOT SCALE = 10.0000' / IN.	DRAWN - ESC	REVISED -
PLOT DATE = 10/19/2011	CHECKED - AM	REVISED -
	DATE - 10/14/2011	REVISED -

STATE OF ILLINOIS
DEPARTMENT OF TRANSPORTATION

BRIDGE MOUNT SIGN LIGHTING TYPICAL WIRING 2

SCALE: NTS SHEET NO. OF SHEETS STA. TO STA.

F.A.I. RTE. 90	SECTION (X2-1)R	COUNTY WINNEBAGO	TOTAL SHEETS 510	SHEET NO. 290
				CONTRACT NO. 64C29
ILLINOIS FED. AID PROJECT				

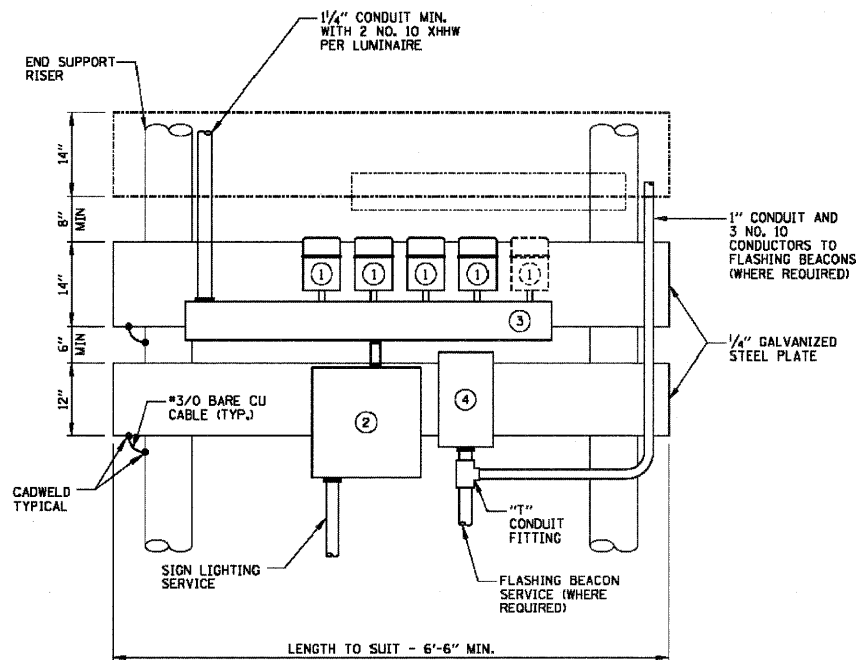

LEGEND:

- ① WEATHERPROOF CANNISTER BALLAST (BALLAST SHALL BE MARKED TO IDENTIFY WHICH LUMINAIRE IT IS WIRED).
- ② SIGN LIGHTING SERVICE - CIRCUIT BREAKER (30 AMP/2 POLE) IN NEMA TYPE 4 C.I. ENCLOSURE, OZ TYPE "YW" WITH MOUNTING FEET OR APPROVED EQUAL.
- ③ 6"x6" HOT DIPPED GALVANIZED WEATHERPROOF WIREWAY (LENGTH TO SUIT).
- ④ FLASHING BEACON CONTROLLER.

NOTES:

1. CONDUIT AND FITTINGS ATTACHED TO THE HORIZONTAL ALUMINUM SIGN TRUSS SHALL BE ALUMINUM. GALVANIZED STEEL CONDUIT AND CAST IRON ALLOY FITTINGS SHALL BE UTILIZED WHERE ATTACHED TO STEEL TRUSS END SUPPORT RISERS. THREADED JOINTS BETWEEN DISSIMILAR METALS SHALL BE COATED WITH AN APPROVED THREAD LUBRICANT.
2. PROVIDE 12" FLASHING BEACON ONLY WHERE INDICATED ON PLANS. FLASHING BEACON TO BE ATTACHED TO SUPPORT WITH STAINLESS STEEL SCREWS AND NEOPRENE SPACERS. DRILLED SCREW HOLES TO BE SEALED WATERTIGHT.
3. ALL EQUIPMENT SHALL BE GROUNDED IN ACCORDANCE WITH THE NATIONAL ELECTRICAL CODE AND THE NATIONAL ELECTRICAL SAFETY CODE.
4. ALL STEEL TO BE HOT DIPPED GALVANIZED AFTER WELDING PER THE STANDARD SPECIFICATIONS.
5. FOR DIMENSION "H" SEE CONTRACT PLANS.

TYPICAL SIGN LIGHTING CONTROL PANEL

FOR WIRING DIAGRAMS SEE STANDARD H14 (SIGN LUMINAIRE MOUNTING DETAIL AND WIRING DIAGRAMS) NO SCALE

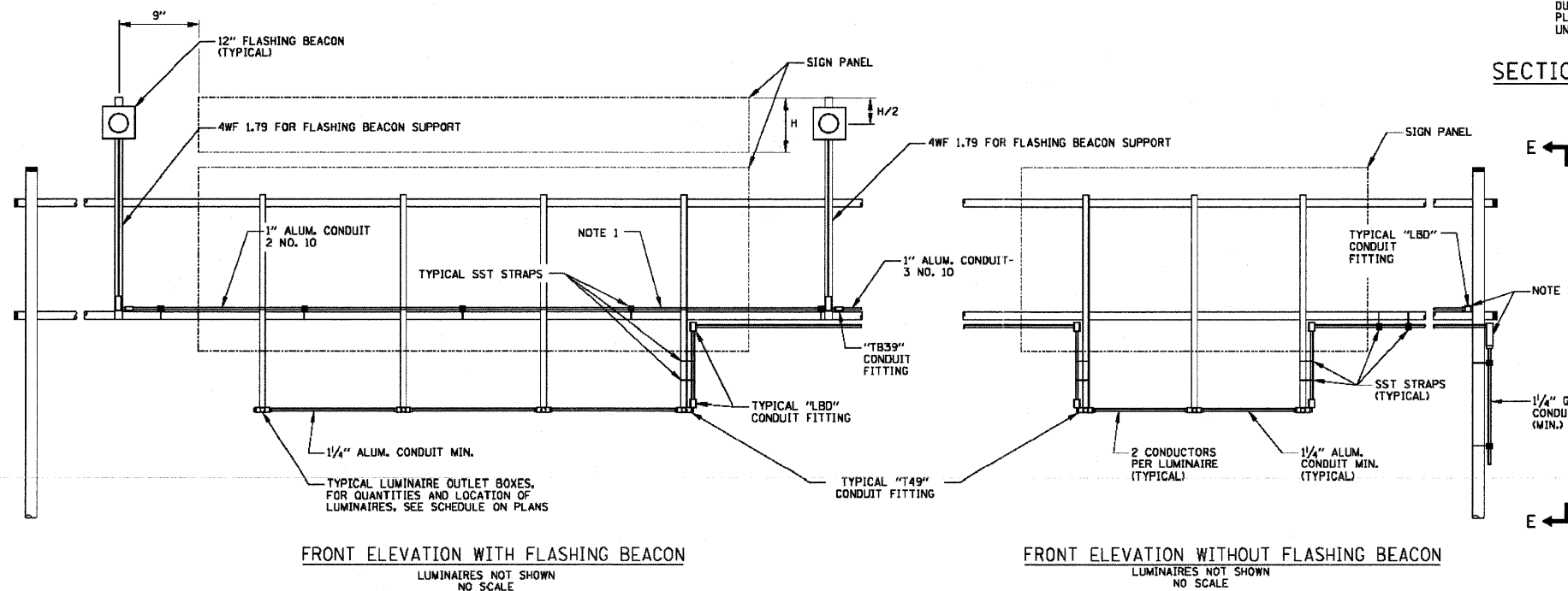

TYPICAL SIGN PANEL ELEVATIONS
NO SCALE

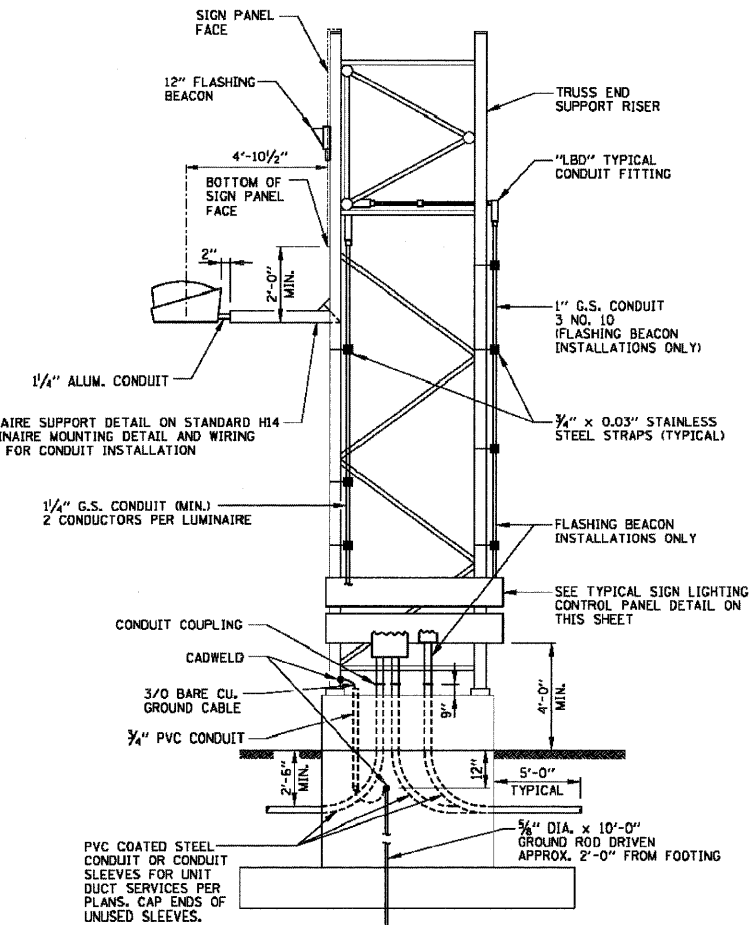

SECTION E-E - FULL ELEVATION (OUTSIDE FOUNDATION)
NO SCALE

APPROVED *Jeff Daley* DATE 1-1-2007...



DATE	REVISIONS

OVERHEAD TRUSS SIGN LIGHTING WITHOUT CATWALK
TYPICAL WIRING DETAILS
STANDARD H11-00

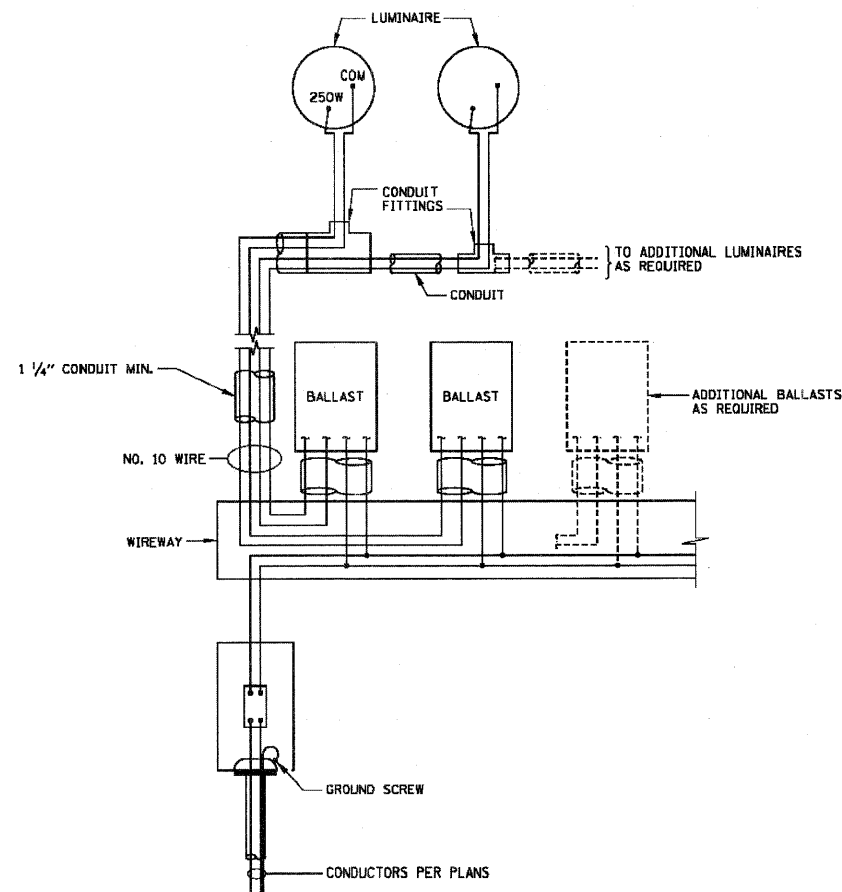

SIGN WIRING DIAGRAM
NO SCALE

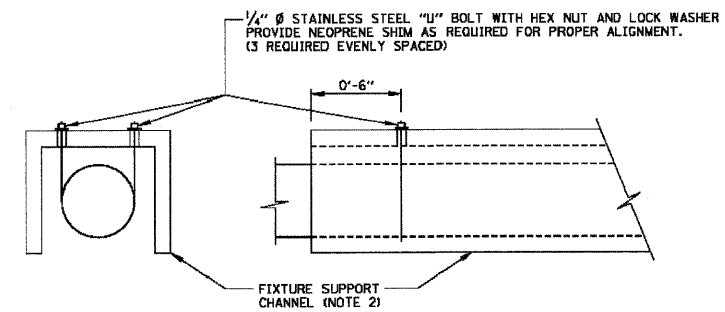

LUMINAIRE SUPPORT DETAIL
NO SCALE

NOTES:

- HOLES WHICH ARE FIELD DRILLED IN STRUCTURAL STEEL MEMBERS SHALL BE PAINTED WITH ONE (1) COAT OF ZINC PAINT IMMEDIATELY FOLLOWING DRILLING. THE PAINT SHALL CONFORM TO FEDERAL SPECIFICATION TT-P641b TYPE 2 FOR GALVANIZING PRIMER.
- SEE STRUCTURAL DRAWINGS FOR DETAILS OF FIXTURE SUPPORT CHANNELS. SUPPORT CHANNELS ARE ALUMINUM (1/4"x2") FOR TRUSS TYPE AND CANTILEVER TYPE SIGN STRUCTURES AND STEEL (C5x9) FOR BRIDGE MOUNTED SIGNS.

APPROVED: *Jeff Daley* DATE 1-1-2007
CHIEF ENGINEER



DATE	REVISIONS

SIGN LUMINAIRE MOUNTING DETAIL AND WIRING DIAGRAMS
STANDARD H14-00



USER NAME = .USERNAME.	DESIGNED - AM	REVISED -
	DRAWN - ESC	REVISED -
PLOT SCALE = 10.0000' / IN.	CHECKED - AM	REVISED -
PLOT DATE = 10/19/2011	DATE - 10/14/2011	REVISED -

STATE OF ILLINOIS
DEPARTMENT OF TRANSPORTATION

SIGN LUMINAIRE MOUNTING DETAILS
AND WIRING DETAILS

SCALE: NTS SHEET NO. OF SHEETS STA. TO STA.

F.A.I. RTE.	SECTION	COUNTY	TOTAL SHEETS	SHEET NO.
90	(X2-1)R	WINNEBAGO	510	292
CONTRACT NO. 64C29				
ILLINOIS FED. AID PROJECT				

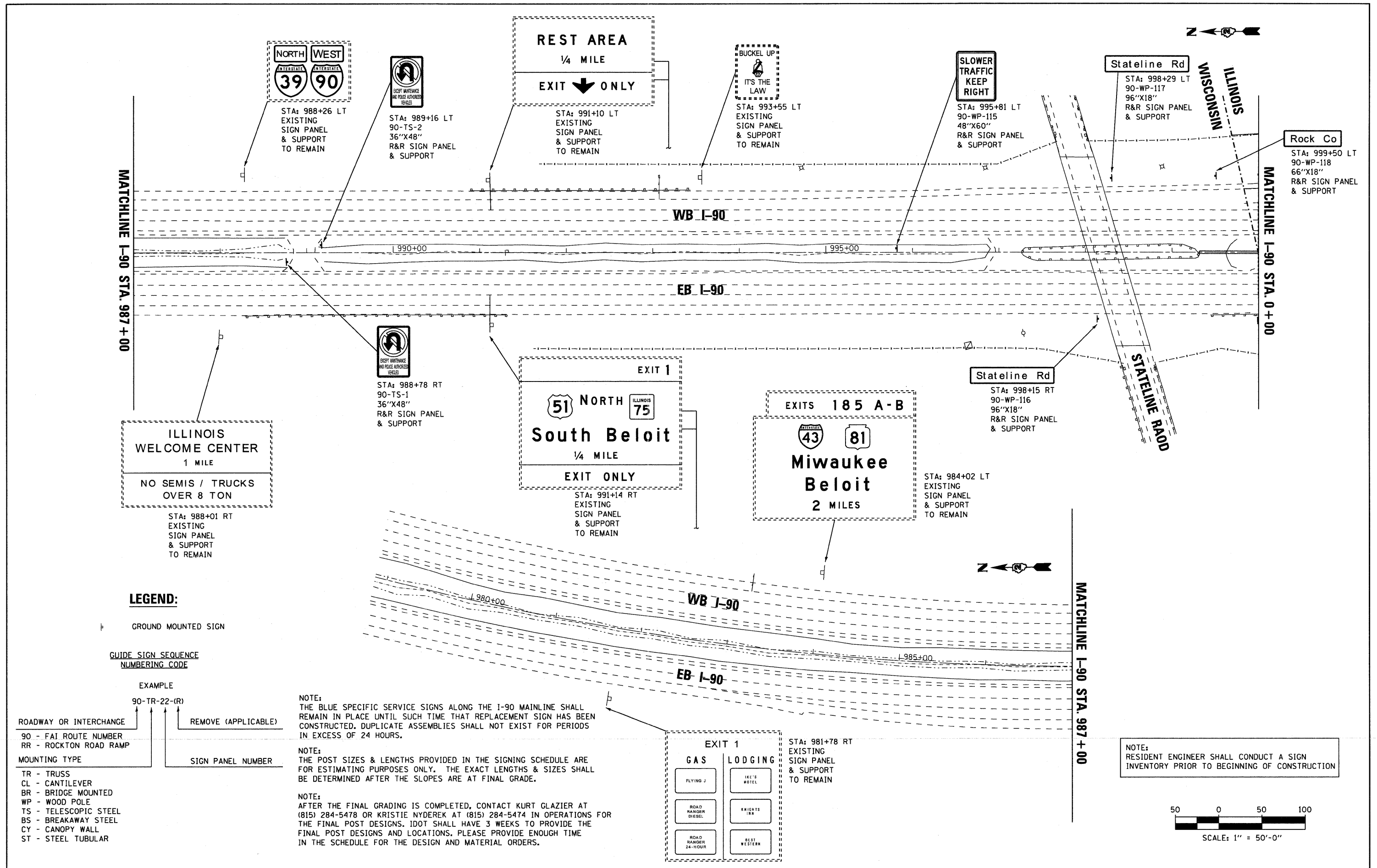

LEGEND:

GROUND MOUNTED SIGN

GUIDE SIGN SEQUENCE NUMBERING CODE

EXAMPLE
 90-TR-22-(R)
 90 - FAI ROUTE NUMBER
 TR - TRUSS
 RR - ROCKTON ROAD RAMP
 MOUNTING TYPE
 SIGN PANEL NUMBER

REMOVE (APPLICABLE)

NOTE:
 THE BLUE SPECIFIC SERVICE SIGNS ALONG THE I-90 MAINLINE SHALL REMAIN IN PLACE UNTIL SUCH TIME THAT REPLACEMENT SIGN HAS BEEN CONSTRUCTED. DUPLICATE ASSEMBLIES SHALL NOT EXIST FOR PERIODS IN EXCESS OF 24 HOURS.

NOTE:
 THE POST SIZES & LENGTHS PROVIDED IN THE SIGNING SCHEDULE ARE FOR ESTIMATING PURPOSES ONLY. THE EXACT LENGTHS & SIZES SHALL BE DETERMINED AFTER THE SLOPES ARE AT FINAL GRADE.

NOTE:
 AFTER THE FINAL GRADING IS COMPLETED, CONTACT KURT GLAZIER AT (815) 284-5478 OR KRISTIE NYDEREK AT (815) 284-5474 IN OPERATIONS FOR THE FINAL POST DESIGNS. IDOT SHALL HAVE 3 WEEKS TO PROVIDE THE FINAL POST DESIGNS AND LOCATIONS. PLEASE PROVIDE ENOUGH TIME IN THE SCHEDULE FOR THE DESIGN AND MATERIAL ORDERS.

NOTE:
 RESIDENT ENGINEER SHALL CONDUCT A SIGN INVENTORY PRIOR TO BEGINNING OF CONSTRUCTION

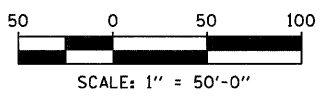

NOTE:
RESIDENT ENGINEER SHALL CONDUCT A SIGN
INVENTORY PRIOR TO BEGINNING OF CONSTRUCTION

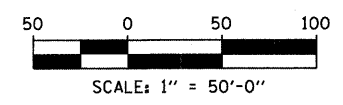
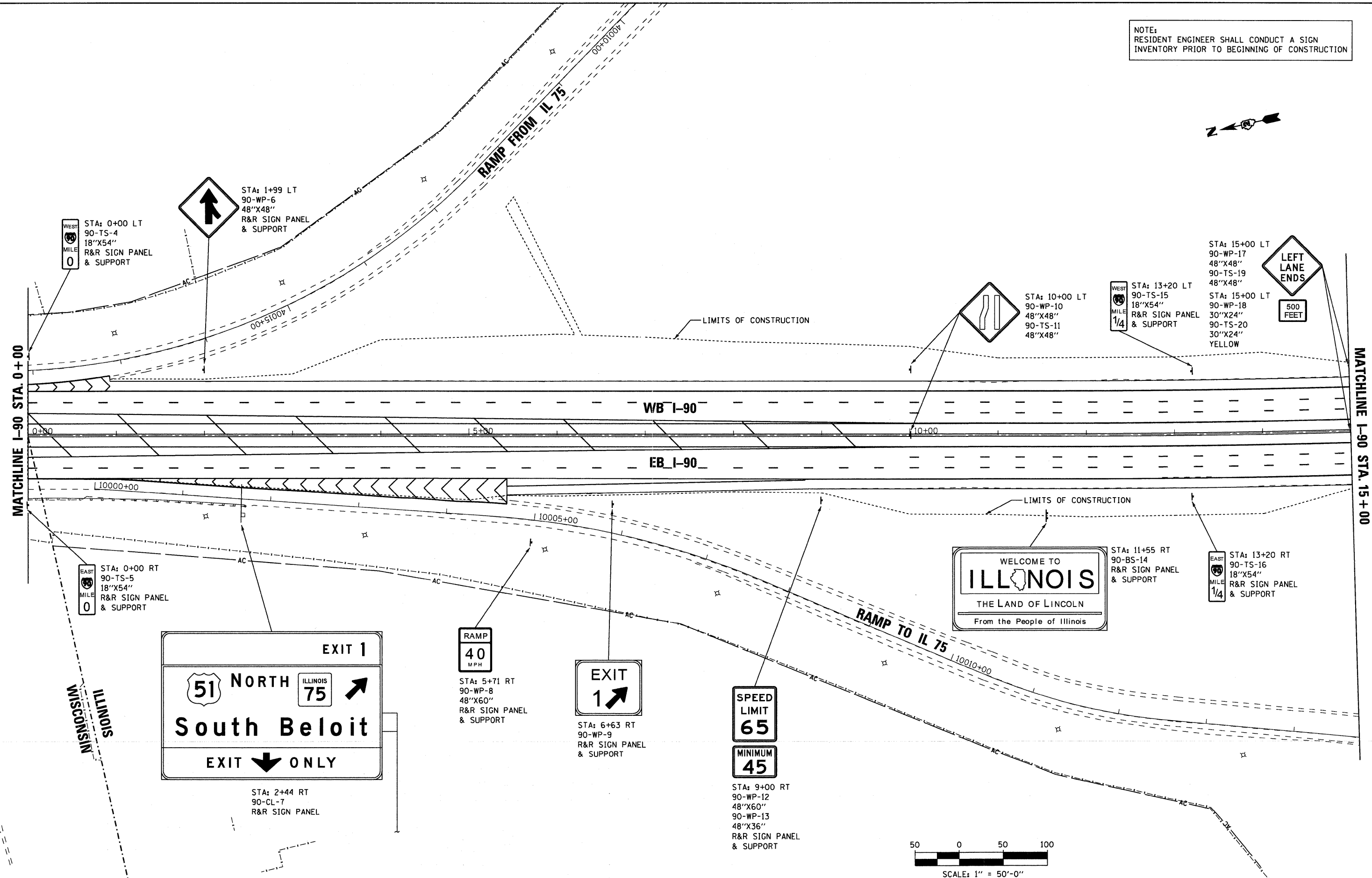

	USER NAME = .USERNAME.	DESIGNED -	REVISED -	STATE OF ILLINOIS DEPARTMENT OF TRANSPORTATION	EXISTING AND PROPOSED SIGNING PLAN I-90 FROM WISCONSIN STATE LINE TO ROCKTON ROAD	F.A.I. RTE.	SECTION	COUNTY	TOTAL SHEETS	SHEET NO.
			DRAWN - JDH CHECKED - DW DATE - 10-21-2011			REVISED - REVISED - REVISED -	90	(X2-1) R	WINNEBAGO	510
SCALE: 1"=50'-0" SHEET NO. 2 OF 9 SHEETS STA. 0+00 TO STA. 15+00						CONTRACT NO. 64C29 ILLINOIS FED. AID PROJECT				

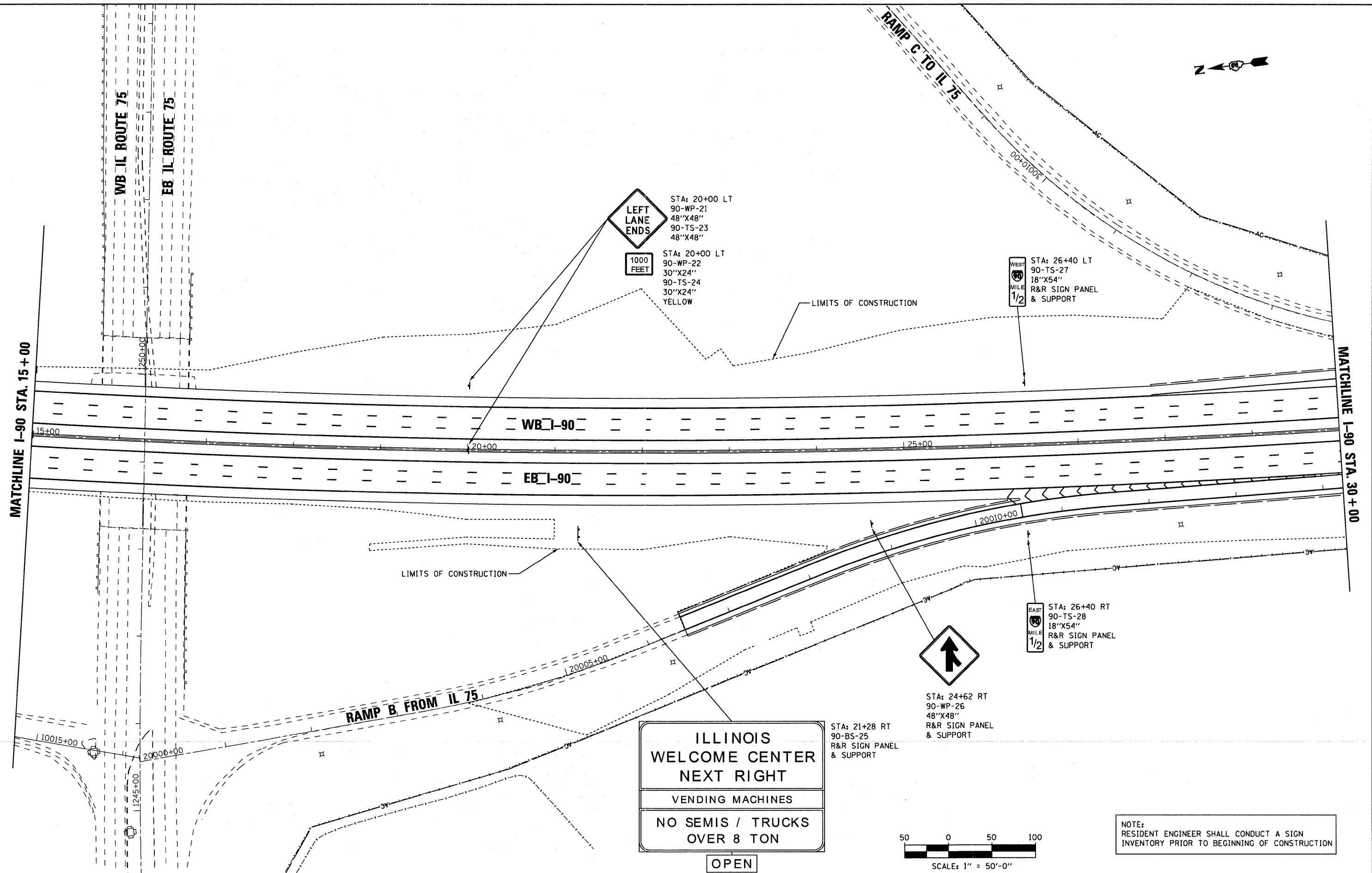

ILLINOIS
WELCOME CENTER
NEXT RIGHT
 VENDING MACHINES
 NO SEMIS / TRUCKS
 OVER 8 TON
 OPEN

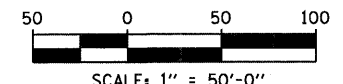

NOTE:
RESIDENT ENGINEER SHALL CONDUCT A SIGN
INVENTORY PRIOR TO BEGINNING OF CONSTRUCTION



USER NAME = .USERNAME.	DESIGNED -	REVISED -
PLOT SCALE = 50,0000' / IN.	DRAWN - JDH	REVISED -
PLOT DATE = 10/19/2011	CHECKED - DW	REVISED -
	DATE - 10-21-2011	REVISED -

STATE OF ILLINOIS
DEPARTMENT OF TRANSPORTATION

EXISTING AND PROPOSED SIGNING PLAN
I-90 FROM WISCONSIN STATE LINE TO ROCKTON ROAD
 SCALE: 1"=50'-0" SHEET NO. 3 OF 9 SHEETS STA. 15+00 TO STA. 30+00

F.A.I. RTE.	SECTION	COUNTY	TOTAL SHEETS	SHEET NO.
90	(X2-1) R	WINNEBAGO	510	295
CONTRACT NO. 64C29				
ILLINOIS FED. AID PROJECT				

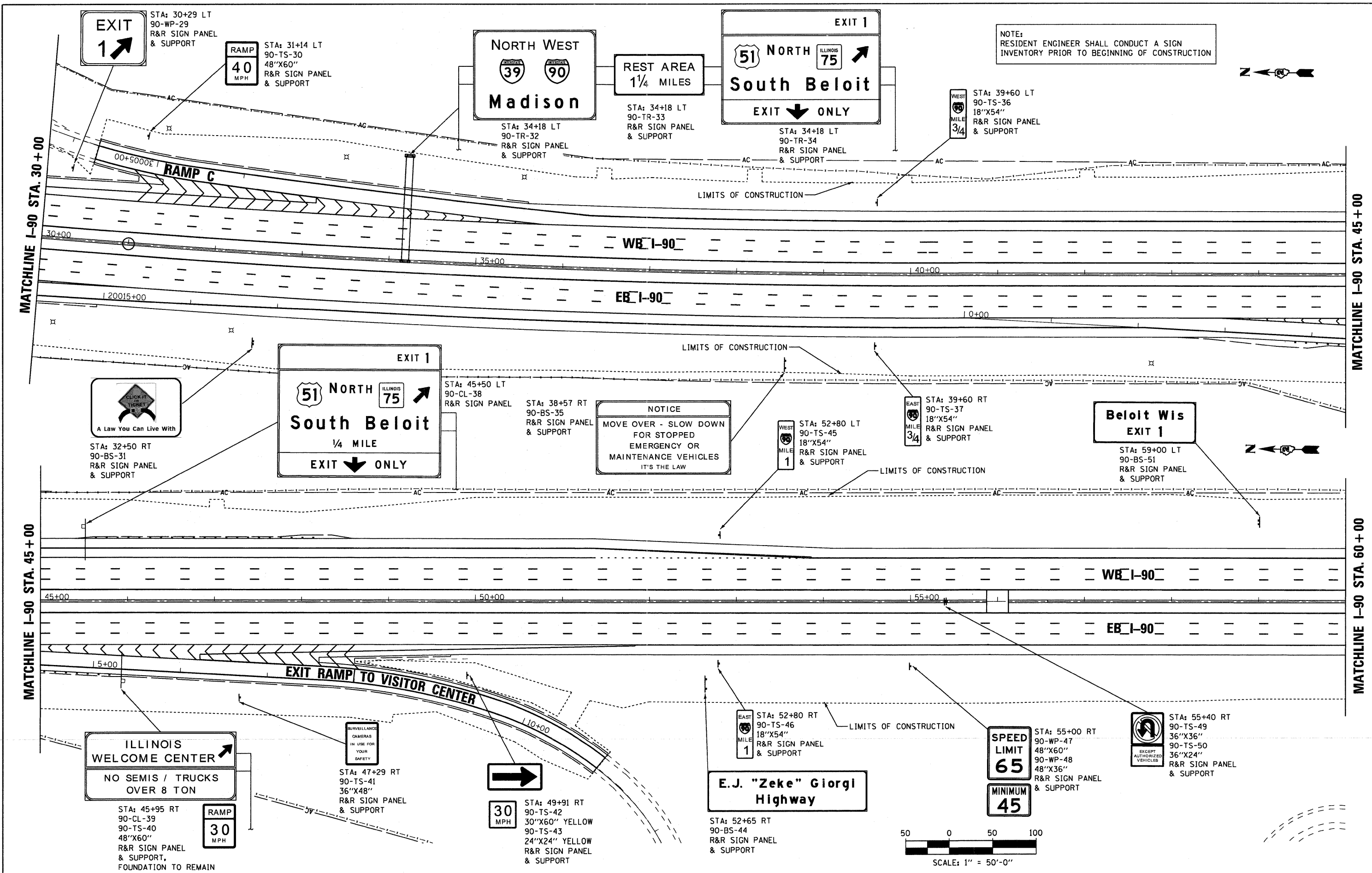

NOTE:
RESIDENT ENGINEER SHALL CONDUCT A SIGN
INVENTORY PRIOR TO BEGINNING OF CONSTRUCTION

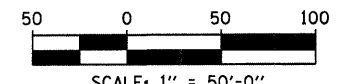
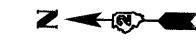

 	USER NAME = _USERNAME_	DESIGNED -	REVISED -	STATE OF ILLINOIS DEPARTMENT OF TRANSPORTATION	EXISTING AND PROPOSED SIGNING PLAN I-90 FROM WISCONSIN STATE LINE TO ROCKTON ROAD			F.A.I. RTE.	SECTION	COUNTY	TOTAL SHEETS	SHEET NO.
	PLOT SCALE = 50,0000' / IN.	CHECKED - DW	REVISED -		90	(X2-1) R	WINNEBAGO	510	296			
PLOT DATE = 12/19/2011	DATE - 10-21-2011	REVISED -	REVISED -	SCALE: 1"=50'-0"	SHEET NO. 4 OF 9 SHEETS	STA. 30+00	TO STA. 60+00	CONTRACT NO. 64C29 ILLINOIS FED. AID PROJECT				

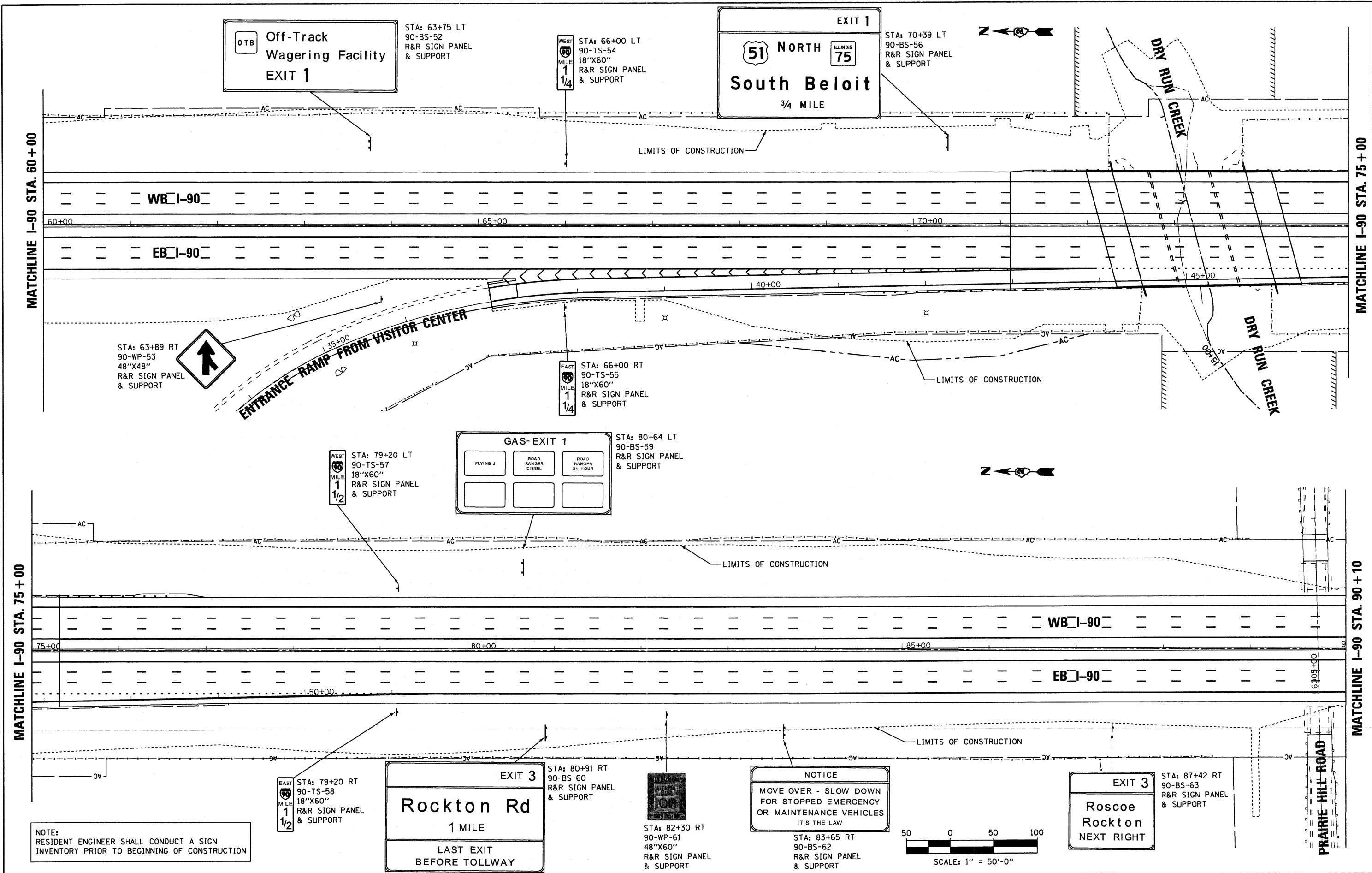

STA: 63+89 RT
90-WP-53
48"X48"
R&R SIGN PANEL
& SUPPORT



ENTRANCE RAMP FROM VISITOR CENTER

WEST
MILE
1
1/4
STA: 66+00 LT
90-TS-54
18"X60"
R&R SIGN PANEL
& SUPPORT

EXIT 1
51 NORTH ILLINOIS 75
South Beloit
3/4 MILE

STA: 70+39 LT
90-B5-56
R&R SIGN PANEL
& SUPPORT

EAST
MILE
1
1/4
STA: 66+00 RT
90-TS-55
18"X60"
R&R SIGN PANEL
& SUPPORT

WEST
MILE
1
1/2
STA: 79+20 LT
90-TS-57
18"X60"
R&R SIGN PANEL
& SUPPORT

GAS-EXIT 1
FLYING J
ROAD RANGER DIESEL
ROAD RANGER 24-HOUR

STA: 80+64 LT
90-B5-59
R&R SIGN PANEL
& SUPPORT

EAST
MILE
1
1/2
STA: 79+20 RT
90-TS-58
18"X60"
R&R SIGN PANEL
& SUPPORT

EXIT 3
Rockton Rd
1 MILE
LAST EXIT
BEFORE TOLLWAY

STA: 80+91 RT
90-B5-60
R&R SIGN PANEL
& SUPPORT

STA: 82+30 RT
90-WP-61
48"X60"
R&R SIGN PANEL
& SUPPORT

NOTICE
MOVE OVER - SLOW DOWN
FOR STOPPED EMERGENCY
OR MAINTENANCE VEHICLES
IT'S THE LAW

STA: 83+65 RT
90-B5-62
R&R SIGN PANEL
& SUPPORT

EXIT 3
Roscoe
Rockton
NEXT RIGHT

STA: 87+42 RT
90-B5-63
R&R SIGN PANEL
& SUPPORT

NOTE:
RESIDENT ENGINEER SHALL CONDUCT A SIGN
INVENTORY PRIOR TO BEGINNING OF CONSTRUCTION

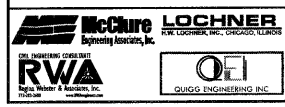
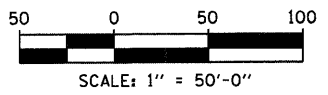

USER NAME = .USERNAME.	DESIGNED -	REVISED -
PLOT SCALE = 50.0000' / IN.	DRAWN - JDH	REVISED -
PLOT DATE = 10/19/2011	CHECKED - DW	REVISED -
	DATE - 10-21-2011	REVISED -

STATE OF ILLINOIS
DEPARTMENT OF TRANSPORTATION

EXISTING AND PROPOSED SIGNING PLAN
I-90 FROM WISCONSIN STATE LINE TO ROCKTON ROAD
SCALE: 1"=50'-0" SHEET NO. 5 OF 9 SHEETS STA. 60+00 TO STA. 90+10

F.A.I. RTE.	SECTION	COUNTY	TOTAL SHEETS	SHEET NO.
90	(X2-1) R	WINNEBAGO	510	297
CONTRACT NO. 64C29			ILLINOIS FED. AID PROJECT	

NOTE:
CONTRACTOR TO INSTALL THE DMS
AT STA: 93+50 LT, DMS SHALL BE
PROVIDED BY WISDOT.

WEST
MILE
1
3/4
STA: 92+40 LT
90-TS-64
18"X60"
R&R SIGN PANEL
& SUPPORT

**WisDot
DMS**
STA: 93+50 LT
90-TR-128
SIGN PANEL
& SUPPORT

Beloit EXITS
Ill 75 1 1/2
Wis 81 5 1/2
Hwy S 7 1/2

STA: 94+94 LT
90-BS-67
R&R SIGN PANEL
& SUPPORT

FOOD-EXIT 1
DENNY'S
SUBWAY
BEEFAROO
McD'S

STA: 103+33 LT
90-BS-69
R&R SIGN PANEL
& SUPPORT

MATCHLINE I-90 STA. 90+10

MATCHLINE I-90 STA. 105+00

0+00

95+00

100+00

WB I-90

EB I-90

EAST
MILE
1
3/4
STA: 92+40 RT
90-TS-65
18"X60"
R&R SIGN PANEL
& SUPPORT

FOOD-EXIT 3
HARDEE'S
ARBY'S

STA: 94+62 RT
90-BS-66
R&R SIGN PANEL
& SUPPORT

LODGING-EXIT 1
KNIGHTS INN
SOUTH BELMONT INN
BEST WESTERN

STA: 110+54 LT
90-BS-73
R&R SIGN PANEL
& SUPPORT

**SPEED
LIMIT
65**
**MINIMUM
45**

STA: 112+65 LT
90-WP-74
48"X60"
90-WP-75
48"X36"
R&R SIGN PANEL
& SUPPORT

EXIT 3
Rockton Rd
1/2 MILE

STA: 100+84 RT
90-BS-68
R&R SIGN PANEL
& SUPPORT

CAMPING-EXIT 1
PEARL LAKE
ATTRACTIONS-EXIT 1
ROSDALE ANTIQUE MALL
ANGELAS ATTIC

WEST
MILE
2
1/4
STA: 118+80 LT
90-TS-76
18"X60"
R&R SIGN PANEL
& SUPPORT

STA: 119+00 LT
90-BS-78
R&R SIGN PANEL
& SUPPORT

WEST
MILE
2
STA: 105+60 LT
90-TS-70
18"X54"
R&R SIGN PANEL
& SUPPORT

MATCHLINE I-90 STA. 105+00

MATCHLINE I-90 STA. 120+00

105+00

110+00

115+00

WB I-90

EB I-90

EAST
MILE
2
STA: 105+60 RT
90-TS-71
18"X54"
R&R SIGN PANEL
& SUPPORT

GAS-EXIT 3
LOVE'S

STA: 108+84 RT
90-BS-72
R&R SIGN PANEL
& SUPPORT

EAST
MILE
2
1/4
STA: 118+80 RT
90-TS-77
18"X60"
R&R SIGN PANEL
& SUPPORT

NOTE:
RESIDENT ENGINEER SHALL CONDUCT A SIGN
INVENTORY PRIOR TO BEGINNING OF CONSTRUCTION

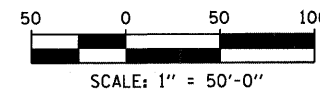

USER NAME = _USERNAME_
DESIGNED -
DRAWN - JDH
CHECKED - DW
DATE - 10-21-2011
PLOT SCALE = 50,0000' / IN.
PLOT DATE = 10/19/2011

REVISED -
REVISED -
REVISED -
REVISED -

STATE OF ILLINOIS
DEPARTMENT OF TRANSPORTATION

EXISTING AND PROPOSED SIGNING PLAN
I-90 FROM WISCONSIN STATE LINE TO ROCKTON ROAD
SCALE: 1"=50'-0" SHEET NO. 6 OF 9 SHEETS STA. 90+10 TO STA. 120+00

F.A.I. RTE.	SECTION	COUNTY	TOTAL SHEETS	SHEET NO.
90	(X2-1) R	WINNEBAGO	510	298
CONTRACT NO. 64C29			ILLINOIS FED. AID PROJECT	

NOTE:
RESIDENT ENGINEER SHALL CONDUCT A SIGN
INVENTORY PRIOR TO BEGINNING OF CONSTRUCTION

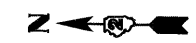

STA: 125+50 LT STA: 125+50 LT STA: 125+50 LT
 90-WP-80 90-WP-82 90-TS-84
 36"X18" 36"X18" 36"X18"
 BLUE BLUE WHITE
 90-WP-81 90-WP-83 90-TS-85
 36" 36" 36"

R&R SIGN PANEL & SUPPORT

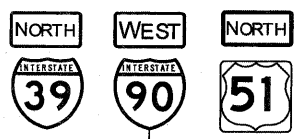

WEST
MILE
2
1/2
STA: 132+00 LT
90-TS-89
18"X60"
R&R SIGN PANEL
& SUPPORT

STA: 134+95 LT
90-WP-92
48"X48"
R&R SIGN PANEL
& SUPPORT



END I-90 CONSTRUCTION
STA. 134+20.40

MATCHLINE I-90 STA. 120+00

MATCHLINE I-90 STA. 135+00

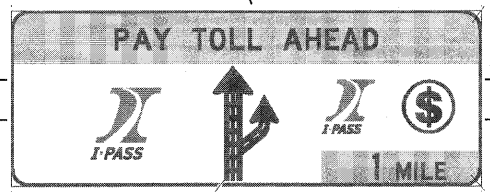
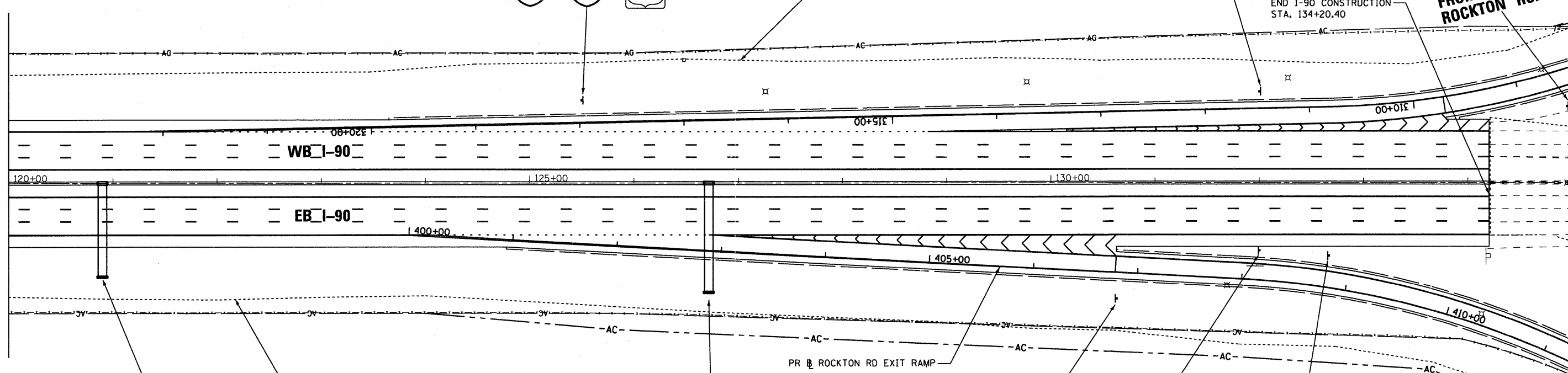

STA: 120+90 RT
90-TR-79
REMOVE & STORE SIGN PANEL
R&R SUPPORT

RAMP
40
MPH
STA: 130+63 RT
90-WP-88
48"X60"
R&R SIGN PANEL
& SUPPORT

EAST
MILE
2
1/2
STA: 132+00 RT
90-TS-90
18"X60"
R&R SIGN PANEL
& SUPPORT

EXIT
3
STA: 132+67 RT
90-WP-91
R&R SIGN PANEL
& SUPPORT

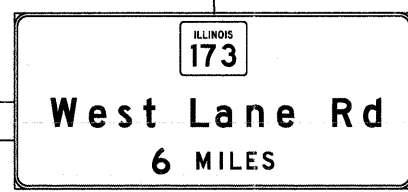

STA: 126+72 RT
90-TR-86
R&R SIGN PANEL
& SUPPORT

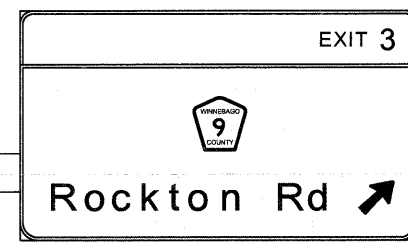

STA: 126+72 RT
90-TR-87
R&R SIGN PANEL
& SUPPORT

NOTE:
THE CONTRACTOR SHALL BE RESPONSIBLE FOR STORING THE TOLLWAY SIGNS PANELS FROM STATIONS: 120+90 RT & 126+72 RT UNTIL SUCH TIME THAT SIGN STRUCTURES HAVE BEEN CONSTRUCTED AND THE SIGN PANELS CAN BE REINSTALLED ON THE NEW STRUCTURES. THE CONTRACTOR SHALL BE RESPONSIBLE FOR STORING THE TOLLWAY SIGN STRUCTURE FROM STATION 147+40 RT UNTIL SUCH TIME THAT THE FOUNDATIONS HAVE BEEN CONSTRUCTED AND THE STRUCTURE CAN BE RELOCATED. THE TOLLWAY SIGN PANEL FROM STATION 147+40 RT SHALL BE TEMPORARILY MOUNTED TO THE ROCKTON ROAD BRIDGE.

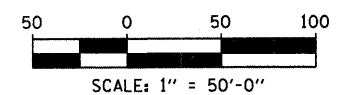

	USER NAME = _USERNAME_	DESIGNED -	REVISED -	STATE OF ILLINOIS DEPARTMENT OF TRANSPORTATION	EXISTING AND PROPOSED SIGNING PLAN I-90 FROM WISCONSIN STATE LINE TO ROCKTON ROAD			F.A.I. RTE.	SECTION	COUNTY	TOTAL SHEETS	SHEET NO.
	PLOT SCALE = 50,0000' / IN.	DRAWN - JDH	REVISED -		90	(X2-1) R	WINNEBAGO	510	299			
PLOT DATE = 10/19/2011	CHECKED - DW	REVISED -	REVISED -	SCALE: 1"=50'-0"	SHEET NO. 7 OF 9 SHEETS	STA. 120+00 TO STA. 135+00	ILLINOIS FED. AID PROJECT CONTRACT NO. 64C29					

MATCHLINE I-90 STA. 135 + 00

NOTE:
RESIDENT ENGINEER SHALL CONDUCT A SIGN
INVENTORY PRIOR TO BEGINNING OF CONSTRUCTION

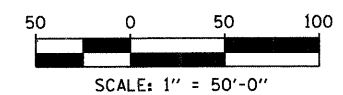
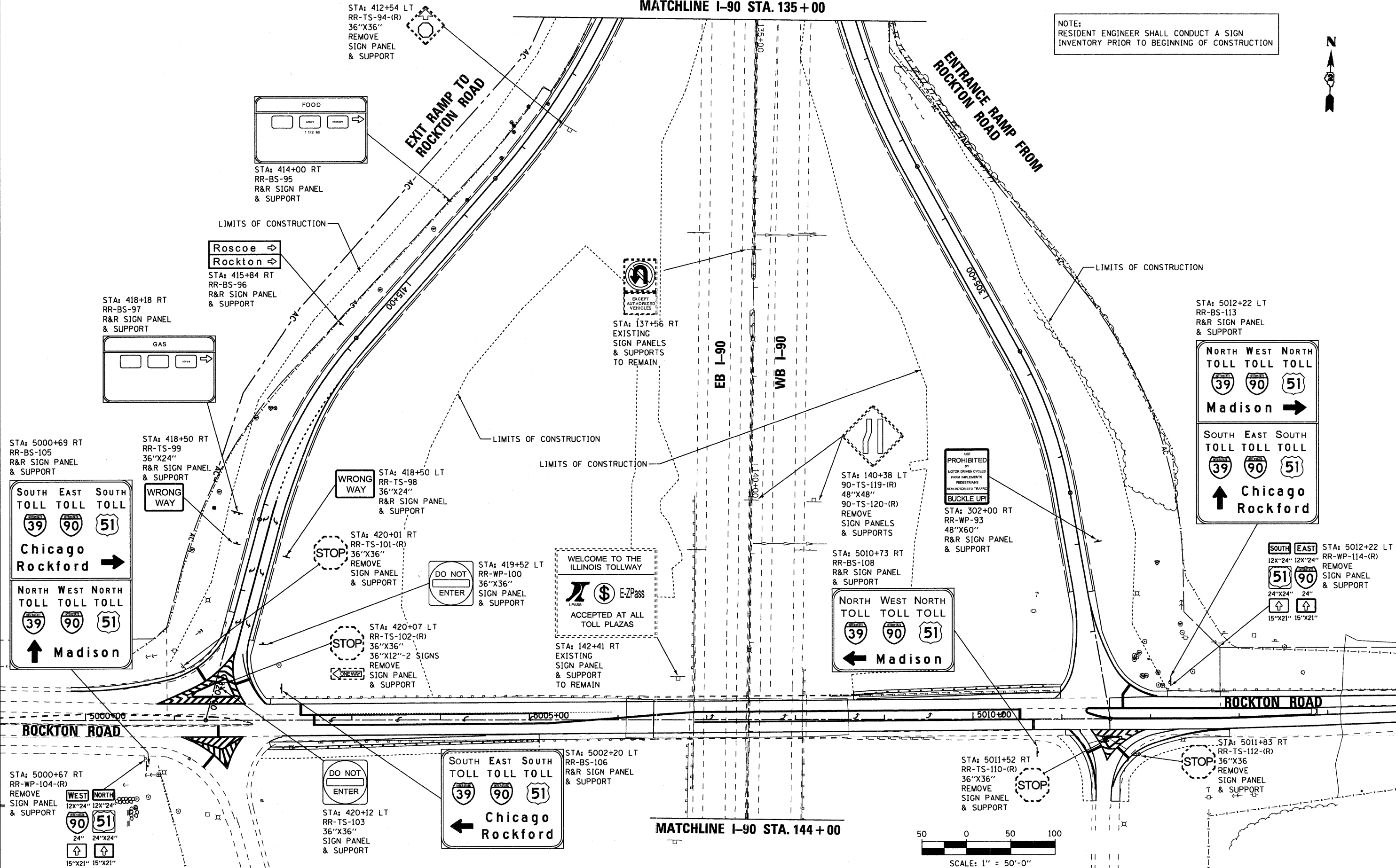

 	USER NAME = _USERNAME_	DESIGNED -	REVISED -	STATE OF ILLINOIS DEPARTMENT OF TRANSPORTATION	EXISTING AND PROPOSED SIGNING PLAN I-90 FROM WISCONSIN STATE LINE TO ROCKTON ROAD			F.A.I. RTE. 90	SECTION (X2-1) R	COUNTY WINNEBAGO	TOTAL SHEETS 510	SHEET NO. 300						
	PLOT SCALE = 50.0000' / IN.	CHECKED - DW	REVISED -		REVISED -	SCALE: 1"=50'-0"	SHEET NO. 8 OF 9 SHEETS	STA. 135+00 TO STA. 144+00	ILLINOIS FED. AID PROJECT CONTRACT NO. 64C29									
STA: 5000+67 RT RR-WP-104-(R) REMOVE SIGN PANEL & SUPPORT	STA: 420+12 LT RR-TS-103 36"X36" SIGN PANEL & SUPPORT	STA: 5002+20 LT RR-B5-106 R&R SIGN PANEL & SUPPORT	STA: 5011+52 RT RR-TS-110-(R) 36"X36" REMOVE SIGN PANEL & SUPPORT	STA: 5012+22 LT RR-B5-113 R&R SIGN PANEL & SUPPORT	STA: 5012+22 LT RR-WP-114-(R) REMOVE SIGN PANEL & SUPPORT	STA: 5010+73 RT RR-B5-108 R&R SIGN PANEL & SUPPORT	STA: 302+00 RT RR-WP-93 48"X60" R&R SIGN PANEL & SUPPORT	STA: 140+38 LT 90-TS-119-(R) 48"X48" 90-TS-120-(R) REMOVE SIGN PANELS & SUPPORTS	STA: 137+56 RT EXISTING SIGN PANELS & SUPPORTS TO REMAIN	STA: 419+52 LT RR-WP-100 36"X36" SIGN PANEL & SUPPORT	STA: 420+07 LT RR-TS-102-(R) 36"X36" 36"X12"-2 SIGNS REMOVE SIGN PANEL & SUPPORT	STA: 420+01 RT RR-TS-101-(R) 36"X36" REMOVE SIGN PANEL & SUPPORT	STA: 418+50 LT RR-TS-98 36"X24" R&R SIGN PANEL & SUPPORT	STA: 418+50 RT RR-TS-99 36"X24" R&R SIGN PANEL & SUPPORT	STA: 418+18 RT RR-B5-97 R&R SIGN PANEL & SUPPORT	STA: 415+84 RT RR-B5-96 R&R SIGN PANEL & SUPPORT	STA: 414+00 RT RR-B5-95 R&R SIGN PANEL & SUPPORT	STA: 412+54 LT RR-TS-94-(R) 36"X36" REMOVE SIGN PANEL & SUPPORT