

**NOTES:**

1. Inserts for  $\frac{3}{4}$ "  $\phi$  threaded dowel rods, when specified, are to be two strut, ferrule type for interior beams and single ferrule, flared loop type for exterior beams.
2. Prestressing steel shall be uncoated high strength, low relaxation 7-wire strand, Grade 270. The nominal diameter shall be  $\frac{1}{2}$ " and the nominal cross-sectional area shall be 0.153 sq. in.
3. Reinforcement bars shall conform to ASTM A 706, Grade 60. (See Special Provisions).
4. A minimum  $2\frac{1}{2}$ "  $\phi$  lifting pin shall be used to engage the lifting loops during handling.
5. Tilt  $G_6$  bars when necessary to maintain  $1\frac{1}{2}$ " clearance.
6. The top and bottom plates shall be AASHTO M270 Grade 50.
7. The bottom plates and studs shall be galvanized according to AASHTO M111. Top plates and threaded rods need not be galvanized.
8. Threaded rods shall be ASTM F 1554 Grade 55.
9. The  $G_6$  bar assembly shall be capable of developing 125 percent of the yield strength of the grade 60 reinforcement bar components. The assembly shall allow completion of the splice without turning of the hook bar. The hook bar shall be threaded such that the entire coupler can be threaded onto the hook bar.
10. Beams requiring  $G_6$  bar assemblies shall not be released from the fabricator until they have attained 45 days of age or older.

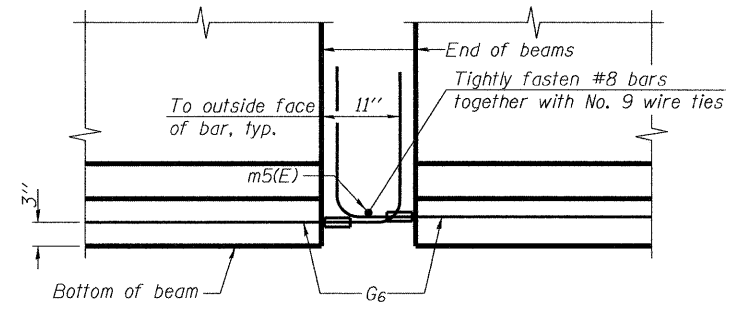

**ELEVATION OF BEAM AT PIER**

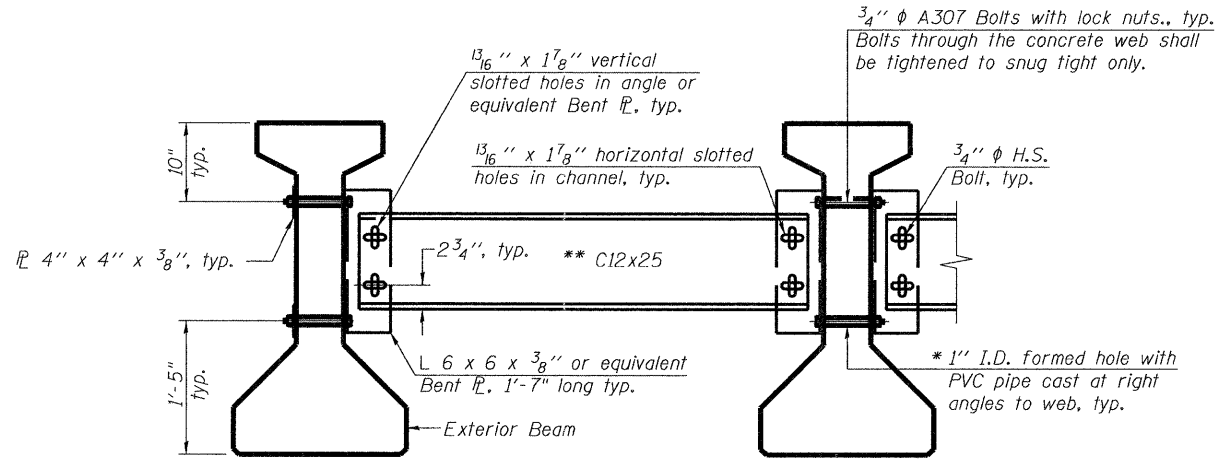

**Notes:**  
 All material for bracing shall be hot dip galvanized according to AASHTO M111 unless otherwise noted.  
 Two hardened washers are required for each set of oversized holes.  
 All holes shall be  $\frac{5}{16}$ "  $\phi$  unless otherwise noted.  
 $\frac{5}{16}$ " x 3" x 3" plate washers are required over all slotted holes.  
 All bolts shall be galvanized according to AASHTO M232.  
 Bracing shall be installed as beams are erected and tightened as soon as possible during erection.  
 Permanent bracing shall not be paid for separately, but shall be included in the cost of Furnishing and Erecting Precast Prestressed Concrete I-Beams, 42".

\* Fabricator shall locate to miss strands within permissible tolerances.  
 \*\* Alternate C12x30 channels are permitted to facilitate material acquisition.

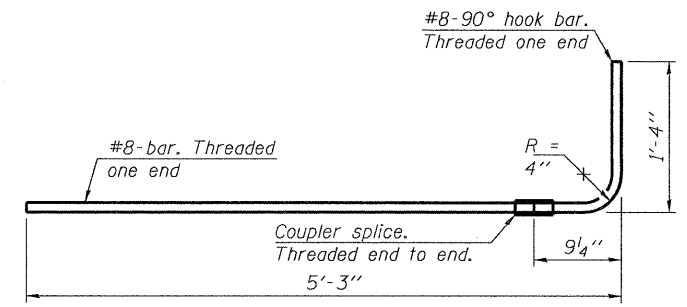

**G6 BAR ASSEMBLY**

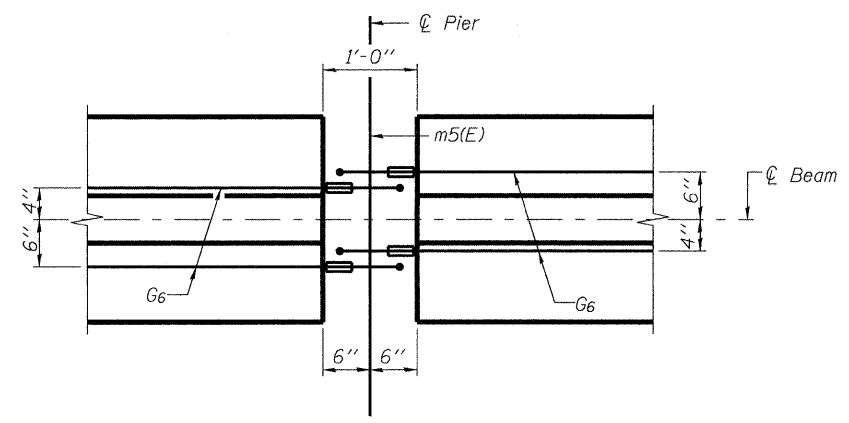

**PLAN OF BEAM AT PIER**

**PERMANENT BRACING DETAILS FOR 42\"/>**

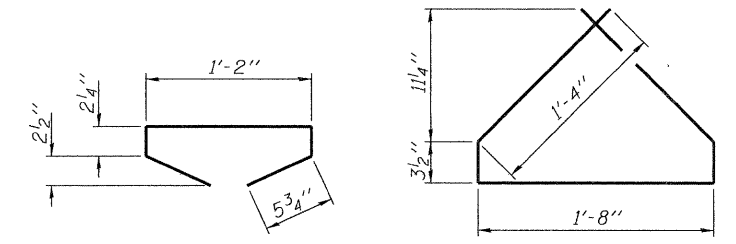

**BAR G5**

**BAR G4**

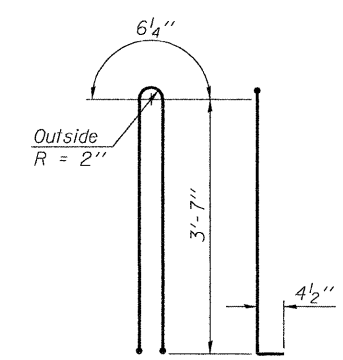

**BAR G1**

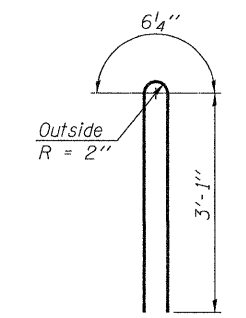

**BAR G2**

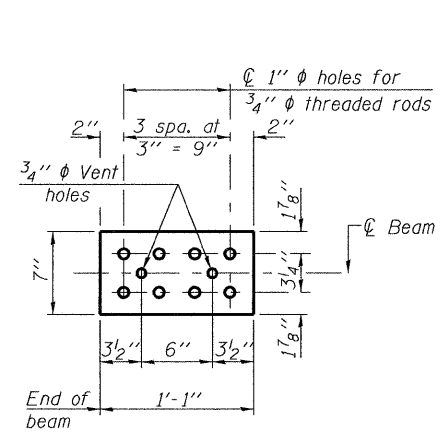

**TOP PLATE**

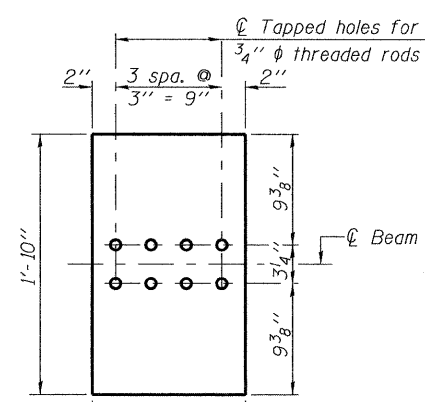

**BOTTOM PLATE**  
(Showing threaded rods)

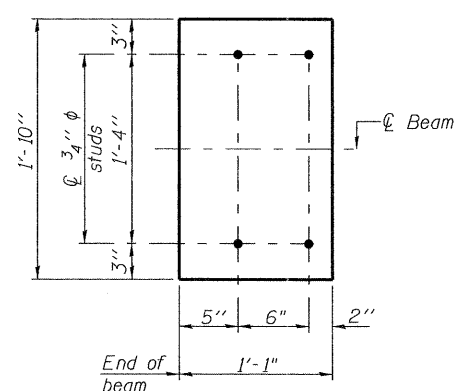

**BOTTOM PLATE**  
(Showing studs)

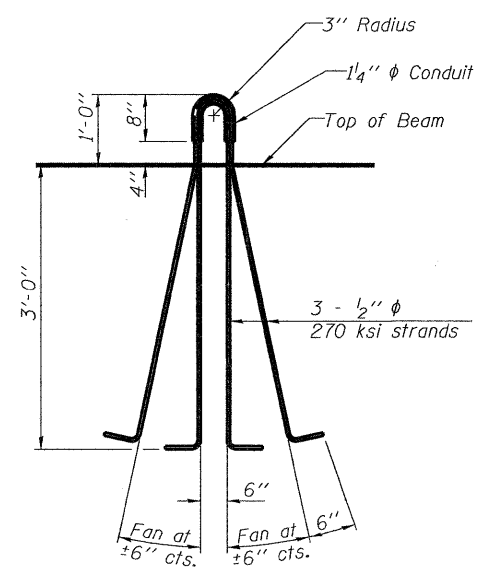

**LIFTING LOOP DETAIL**

See bearing details for pintle hole locations when required.

**BILL OF MATERIAL**

Item	Unit	TOTAL
Furnishing and Erecting Precast Prestressed Concrete I-Beams, 42"	Foot	822

**benesch**  
 engineers · scientists · planners  
 Alfred Benesch & Company  
 205 North Michigan Avenue, Suite 2400  
 Chicago, Illinois 60601  
 312-565-0450 Job No. 3938.11

**PI-4-42D**  
 1-28-11

FILE NAME =	USER NAME = jaurber	DESIGNED - JLS	REVISED -
0500225_66A20_019_ppcbeamd.t.dgn		CHECKED - AJK	REVISED -
		DRAWN - RMG	REVISED -
		CHECKED - HMA	REVISED -

**STATE OF ILLINOIS**  
**DEPARTMENT OF TRANSPORTATION**

**42\"/>
 STRUCTURE NO. 050-0255  
 SHEET NO. S19 OF S35 SHEETS**

F.A.P. RTE.	SECTION	COUNTY	TOTAL SHEETS	SHEET NO.
68	(3)BR-3	LASALLE	61	32
			<b>CONTRACT NO. 66A20</b>	
ILLINOIS FED. AID PROJECT				

x:\3900s\3938\structures\123overbuckcreek\final\plans\0500225\_66A20\_019\_ppcbeamd.t.dgn 08:52:51 11/07/2011