

PLAN AT S. ABUT

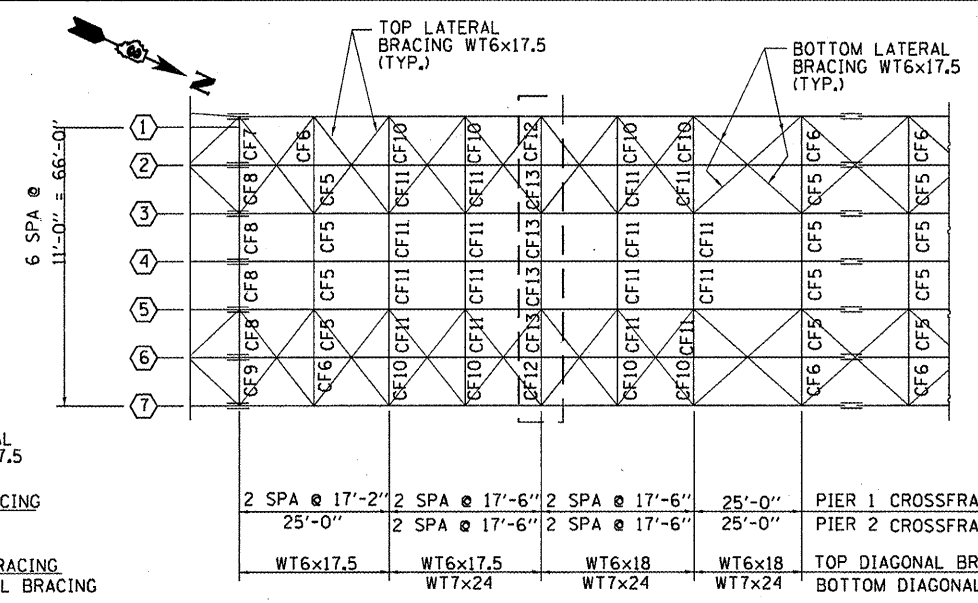

PLAN AT PIER 1 & 2

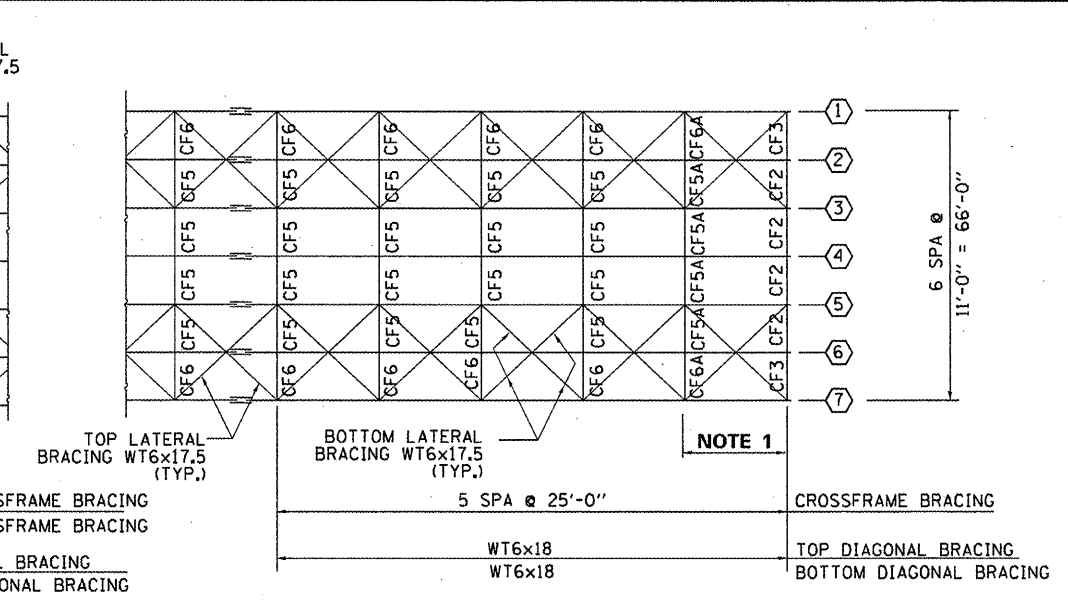

PLAN AT N. ABUT.

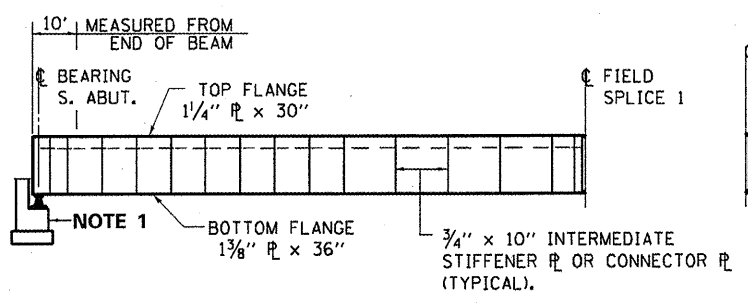

ELEVATION AT S. ABUT.

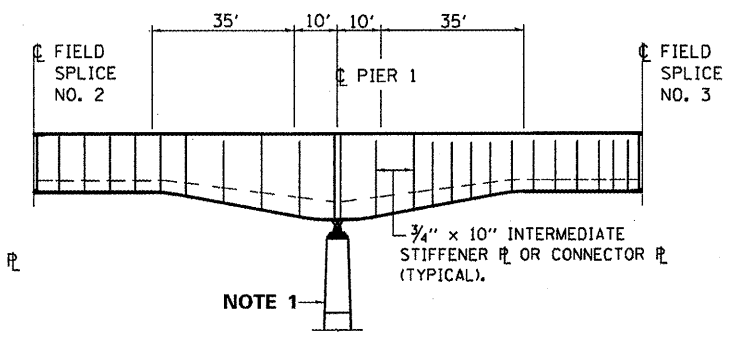

ELEVATION AT PIER 1 & 2

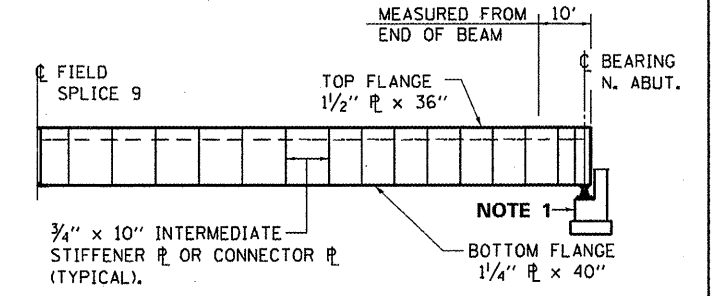
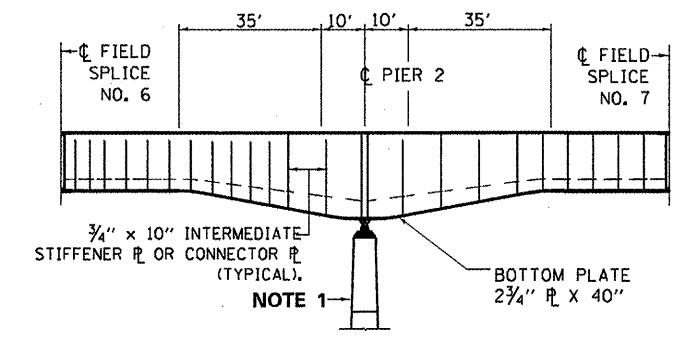

ELEVATION AT N. ABUT.

NOTE 1: CLEAN AND SEAL (REMOVE ALL RUST STAINS) AND SEAL EXPOSED ABUTMENT FACES AND PIERS.

GENERAL NOTES

EXISTING STEEL FLANGE PLATES AND CLAMPS FASTENED TO THE BOTTOM FLANGES AT THE SOUTH ABUTMENT SHALL BE REMOVED PRIOR TO THE CLEANING AND PAINTING OF THE STRUCTURAL STEEL (BEAMS, BEARINGS, ETC.). FLANGE PLATES AND CLAMPS SHALL BE CLEANED AND PAINTED ACCORDING TO THE SPECIAL PROVISION FOR "SURFACE PREPARATION AND PAINTING REQUIREMENTS FOR WEATHERING STEEL". IF THE ENGINEER DETERMINES THAT THE CLAMPS ARE UNUSABLE AFTER REMOVAL, THEY SHALL BE REPLACED WITH AN EQUIVALENT TYPE, AND THE NEW CLAMPS SHALL BE CLEANED AND PAINTED. COST OF THE REPLACEMENT CLAMPS SHALL NOT BE PAID FOR SEPARATELY BUT SHALL BE INCLUDED IN THE COST OF "CLEANING AND PAINTING STEEL BRIDGE".

THE ORGANIC ZINC RICH PRIMER / EPOXY / URETHANE PAINT SYSTEM SHALL BE USED FOR FIELD PAINTING OF EXISTING STRUCTURAL STEEL (WEATHERING STEEL). THE FINISH COAT FOR "ALL" STRUCTURAL STEEL SURFACES" SHALL BE RED BROWN, MUNSELL NO. 2.5YR 3/4.

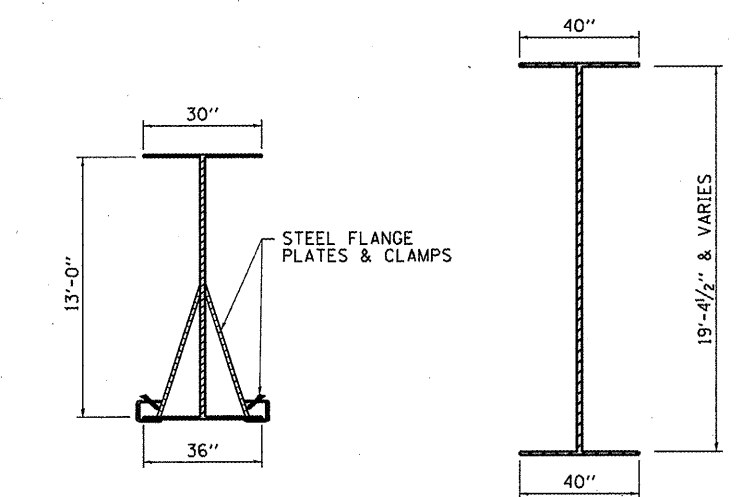

STEEL PLATE GIRDER AT S. ABUT.

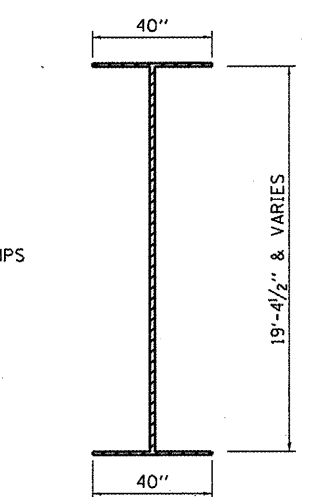

STEEL PLATE GIRDER AT PIER 1 & 2

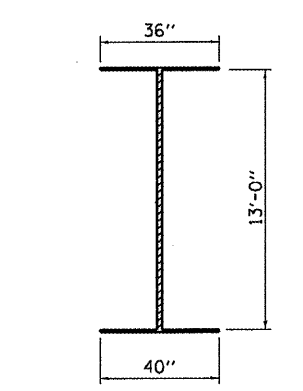

STEEL PLATE GIRDER AT N. ABUT.

FILE NAME =	USER NAME = woodshankr1	DESIGNED -	REVISED -
ct:\pwork\pjd\dot\woodshankr1\d0260492\066833-sht-details.DGN		DRAWN -	REVISED -
PLOT SCALE = 100.0000 / in.		CHECKED -	REVISED -
PLOT DATE = 12/5/2011		DATE -	REVISED -

STATE OF ILLINOIS
DEPARTMENT OF TRANSPORTATION

STEEL FRAMING DETAILS FOR SN 050-0180
SCALE: _____ SHEET NO. 2 OF 9 SHEETS STA. _____ TO STA. _____

F.A.P. RTE. 68	SECTION (12R)-3	COUNTY LASALLE	TOTAL SHEETS 13	SHEET NO. 6
CONTRACT NO. 66B33			ILLINOIS FED. AID PROJECT	

STEEL FRAMING - PLAN
SN 050-0180
FAP ROUTE 68 (IL 23)
OVER ILLINOIS RIVER
SECTION (12R)-2
LASALLE COUNTY