

ROUTE NO.	SECT. NO.	COUNTY	TOTAL SHEETS	SHEET NO.
PA. 821	17BR-1	WAYNE	27	13
JOB NUMBER NO. 1		ILLINOIS PROJECT		

Sheet 9 of 18

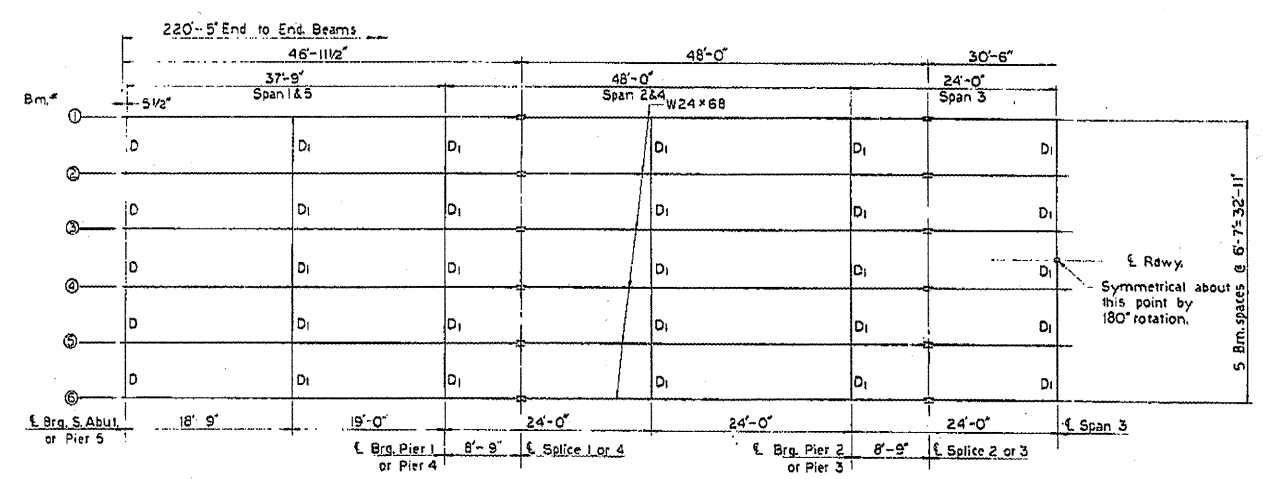

HALF FRAMING PLAN
All Beams are W24x68

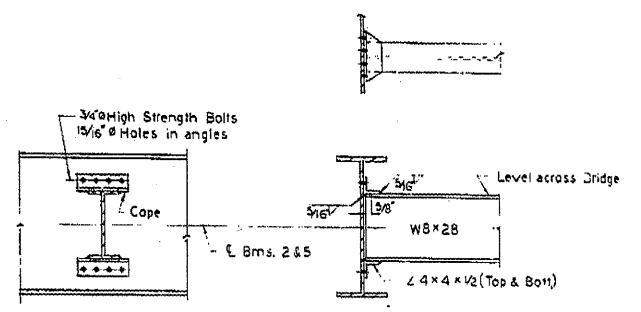

DIAPHRAGM D1
No. Req'd: 45 Each Unit

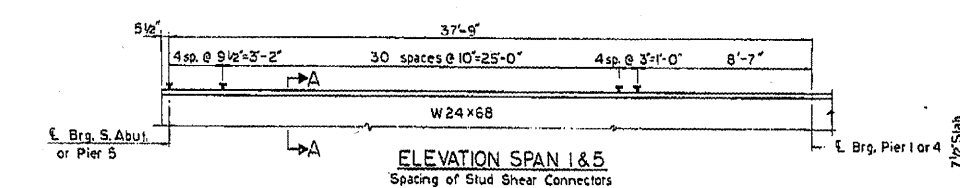

ELEVATION SPAN 1 & 5
Spacing of Stud Shear Connectors

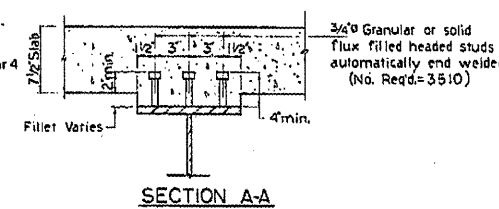

SECTION A-A

NOTE: Hardened washers shall be required over 1 5/16" holes in angles.

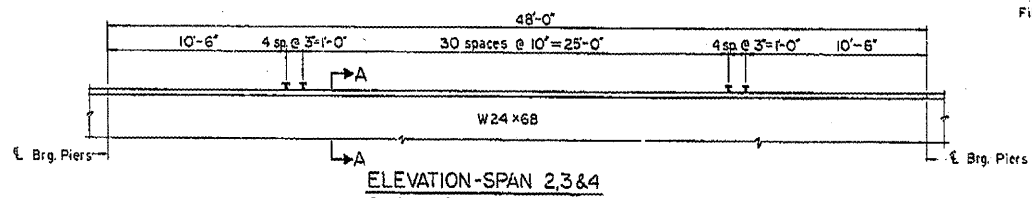

ELEVATION-SPAN 2,3 & 4
Spacing of Stud Shear Connectors

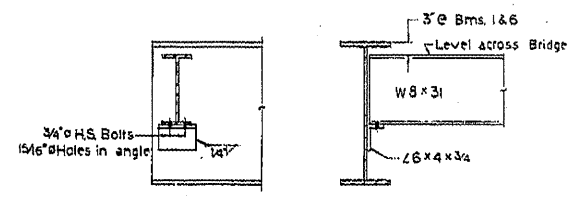

DIAPHRAGM D
No. Req'd: 10 Each Unit

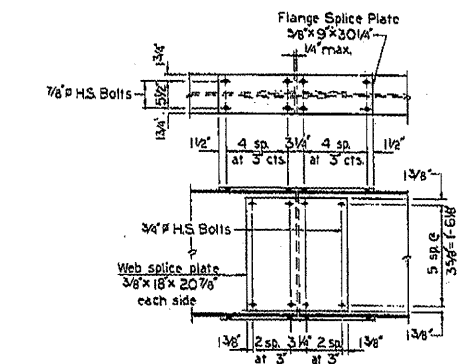

DETAIL OF SPLICE

TOP OF BEAM ELEVATIONS

	Bm. 1 or 6	Bm. 2 or 5	Bm. 3 or 4
ℓ Brg. S. Abut.	411.26	411.40	411.50
ℓ Brg. P-1	411.61	411.75	411.85
ℓ Splice 1	411.69	411.83	411.93
ℓ Brg. P-2	412.01	412.15	412.25
ℓ Splice 2	412.08	412.22	412.32
ℓ Splice 3	412.26	412.40	412.50
ℓ Brg. P-3	412.29	412.43	412.53
ℓ Splice 4	412.44	412.58	412.68
ℓ Brg. P-4	412.46	412.60	412.70
ℓ Brg. Pier 5	412.55	412.69	412.79

The above Elevations are for fabrication only.

UNIT 1
STRUCTURAL STEEL
P.A. 821 SEC. 17BR-1
WAYNE COUNTY
STA. 957+95.03

MTA, INCORPORATED
DESIGNED BY: [Signature] CHECKED BY: [Signature]
DRAWN: L.C.M. DATE: 11-5-78 NO: 0701

11 of 16

74529