

EXISTING LEGEND

- (A) EXISTING BITUMINOUS PAVEMENT
- (B) EXISTING PCC PAVEMENT
- (C) AGGREGATE SHOULDER
- (D) CURB AND GUTTER
- (E) BITUMINOUS SHOULDER
- (F) TEMPORARY PAVEMENT
- (G) AGGREGATE SUBGRADE
- (H) EXISTING SIDEWALK
- [R] = REMOVAL

PROPOSED LEGEND

- (1) PORTLAND CEMENT CONCRETE PAVEMENT 11" (JOINTED)
- (2) PORTLAND CEMENT CONCRETE SHOULDERS 11"
- (3) RETAINING WALL (BY OTHERS)
- (4) AGGREGATE SUBGRADE 12"
- (5) CONCRETE BARRIER, DOUBLE FACE, 42 INCH HEIGHT
- (6) CONCRETE BARRIER BASE
- (7) AGGREGATE SURFACE COURSE, TYPE B, 12" (NOT USED)
- (8) EMBANKMENT
- (9) HOT-MIX ASPHALT SHOULDERS, 8"
- (10) SEEDING & LANDSCAPING BY OTHERS
- (11) HOT-MIX ASPHALT PAVEMENT (FULL-DEPTH), 15.75"
- (12) COMBINATION CONCRETE CURB AND GUTTER, TYPE B-6.12
- (13) COMBINATION CONCRETE CURB AND GUTTER, TYPE B-6.24
- (14) AGGREGATE SHOULDERS, TYPE B 6"
- (15) 42" CONCRETE BARRIER (BY OTHERS)
- (16) STEEL PLATE BEAM GUARDRAIL, TYPE A
- (17) CHAIN LINK FENCE, 6'
- (18) HOT-MIX ASPHALT SURFACE COURSE, MIX "D", N70
- (19) CONCRETE MEDIAN SURFACE, 6"
- (20) STABILIZED SUBBASE - HOT-MIX ASPHALT, 4"
- (21) COMBINATION CONCRETE CURB AND GUTTER, TYPE M-4.24
- (22) PORTLAND CEMENT CONCRETE PAVEMENT 10" (JOINTED)
- (23) PORTLAND CEMENT CONCRETE SHOULDERS 10"
- (24) LONGITUDINAL CONSTRUCTION JOINT WITH NO. 6 TIE BARS AT 24" CTS.
- (25) LONGITUDINAL SAWED JOINT WITH NO. 6 TIE BARS AT 18" CTS.
- (26) LONGITUDINAL SAWED JOINT WITH NO. 6 TIE BARS AT 30" CTS.
- (27) AGGREGATE BASE COURSE, TYPE B 6"
- (28) PORTLAND CEMENT CONCRETE PAVEMENT 12" (JOINTED)
- (29) ANCHORAGE SLAB (BY OTHERS)
- (30) POROUS GRANULAR BACKFILL
- (31) REMOVAL AND DISPOSAL OF UNSUITABLE MATERIAL OR NON-SPECIAL WASTE DISPOSAL
- (32) LIMITS OF ARCHAEOLOGICAL EXPLORATION EARTH EXCAVATION (SPECIAL) AS REQUIRED UNDER PROPOSED ROADWAY SECTION
- (33) PORTLAND CEMENT CONCRETE SHOULDERS 12"
- (34) CONTINUOUSLY REINFORCED PORTLAND CEMENT CONCRETE PAVEMENT 11 1/4" (BY OTHERS)
- (35) PIPE UNDERDRAINS 4"
- (36) PORTLAND CEMENT CONCRETE SIDEWALK 5 INCH
- (37) CONCRETE MEDIAN, TYPE SB-6.12
- (38) CONCRETE MEDIAN, TYPE SB-6.24
- * = BY OTHERS

[] = INDICATES PAYMENT INCLUDED IN COST OF ANOTHER ITEM

NOTE: THE COST OF THE ADDITIONAL THICKNESS OF AGGREGATE SUBGRADE 12" REQUIRED BENEATH THE SHOULDERS SHALL BE INCLUDED IN THE CONTRACT UNIT PRICE PER 50 YD FOR AGGREGATE SUBGRADE 12".

PR. REL. IL ROUTE 3

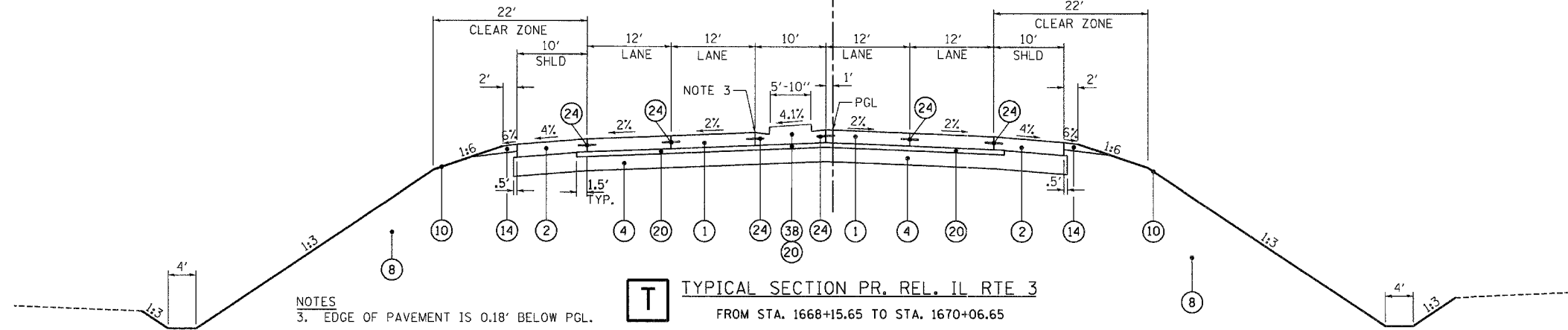

T TYPICAL SECTION PR. REL. IL RTE 3 FROM STA. 1668+15.65 TO STA. 1670+06.65

NOTES
3. EDGE OF PAVEMENT IS 0.18' BELOW PGL.

PR. REL. IL ROUTE 3

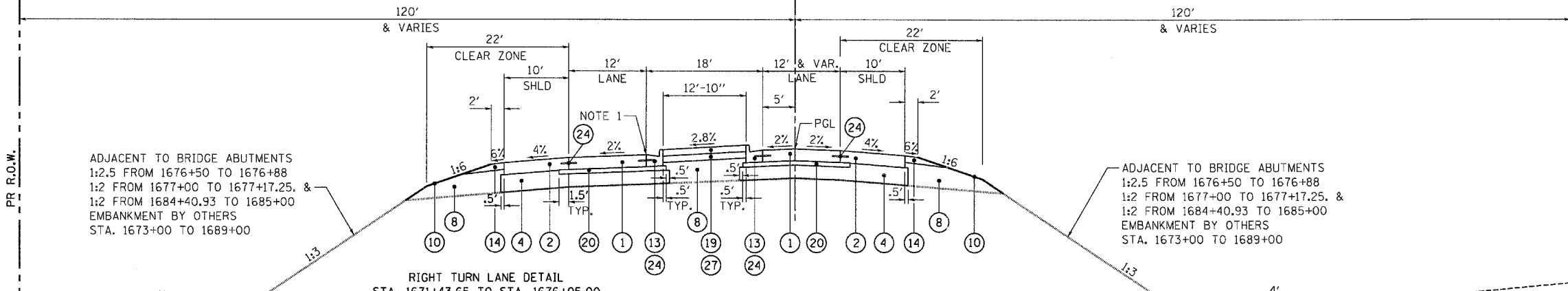

O TYPICAL SECTION PR. REL. IL RTE 3 FROM STA. 1670+06.65 TO STA. 1693+28.38
STRUCTURE OMISSION
STA. 1677+17.25 (BACK OF ABUTMENT) TO STA. 1681+15.86 BY OTHERS
STA. 1681+15.86 TO STA. 1682+67.41 STRUCTURE OMISSION
STA. 1682+67.41 TO STA. 1684+40.93 (BACK OF ABUTMENT)

NOTES
1. EDGE OF PAVEMENT IS 0.46' BELOW PGL.
2. 100' ADJACENT TO APPROACH SLAB SHALL BE BRIDGE APPROACH PAVEMENT CONNECTOR (PCC).

ADJACENT TO BRIDGE ABUTMENTS
1:2.5 FROM 1676+50 TO 1676+88
1:2 FROM 1677+00 TO 1677+17.25. &
1:2 FROM 1684+40.93 TO 1685+00
EMBANKMENT BY OTHERS
STA. 1673+00 TO 1689+00

ADJACENT TO BRIDGE ABUTMENTS
1:2.5 FROM 1676+50 TO 1676+88
1:2 FROM 1677+00 TO 1677+17.25. &
1:2 FROM 1684+40.93 TO 1685+00
EMBANKMENT BY OTHERS
STA. 1673+00 TO 1689+00

RIGHT TURN LANE DETAIL
STA. 1671+43.65 TO STA. 1676+05.00

RIGHT TURN LANE DETAIL
STA. 1671+43.65 TO STA. 1676+05.00
TAPER FROM STA. 1674+05.00 TO STA. 1676+05.00

PR. REL. IL ROUTE 3

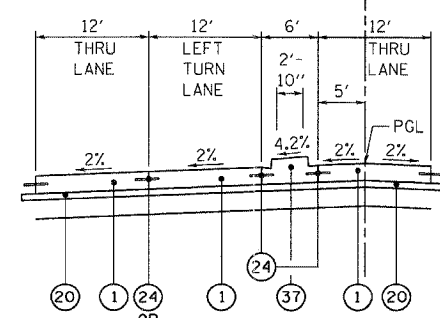

R LEFT TURN LANE DETAIL
12' LEFT TURN LANE STA. 1683+42.51 TO STA. 1685+27.51
PORTIONS OF LEFT TURN LANE ON STR.

PR. REL. IL ROUTE 3

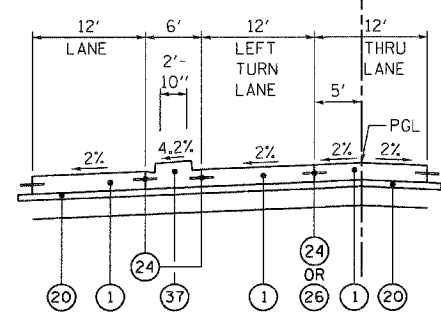

S LEFT TURN LANE DETAIL
12' LEFT TURN LANE STA. 1689+77.98 TO STA. 1692+39.98

\SIBCDON-11-10001.DWG, \SIBCDON-11-10002.DWG, \SIBCDON-11-10003.DWG, \SIBCDON-11-10004.DWG, \SIBCDON-11-10005.DWG, \SIBCDON-11-10006.DWG, \SIBCDON-11-10007.DWG, \SIBCDON-11-10008.DWG, \SIBCDON-11-10009.DWG, \SIBCDON-11-10010.DWG, \SIBCDON-11-10011.DWG, \SIBCDON-11-10012.DWG, \SIBCDON-11-10013.DWG, \SIBCDON-11-10014.DWG, \SIBCDON-11-10015.DWG, \SIBCDON-11-10016.DWG, \SIBCDON-11-10017.DWG, \SIBCDON-11-10018.DWG, \SIBCDON-11-10019.DWG, \SIBCDON-11-10020.DWG, \SIBCDON-11-10021.DWG, \SIBCDON-11-10022.DWG, \SIBCDON-11-10023.DWG, \SIBCDON-11-10024.DWG, \SIBCDON-11-10025.DWG, \SIBCDON-11-10026.DWG, \SIBCDON-11-10027.DWG, \SIBCDON-11-10028.DWG, \SIBCDON-11-10029.DWG, \SIBCDON-11-10030.DWG, \SIBCDON-11-10031.DWG, \SIBCDON-11-10032.DWG, \SIBCDON-11-10033.DWG, \SIBCDON-11-10034.DWG, \SIBCDON-11-10035.DWG, \SIBCDON-11-10036.DWG, \SIBCDON-11-10037.DWG, \SIBCDON-11-10038.DWG, \SIBCDON-11-10039.DWG, \SIBCDON-11-10040.DWG, \SIBCDON-11-10041.DWG, \SIBCDON-11-10042.DWG, \SIBCDON-11-10043.DWG, \SIBCDON-11-10044.DWG, \SIBCDON-11-10045.DWG, \SIBCDON-11-10046.DWG, \SIBCDON-11-10047.DWG, \SIBCDON-11-10048.DWG, \SIBCDON-11-10049.DWG, \SIBCDON-11-10050.DWG, \SIBCDON-11-10051.DWG, \SIBCDON-11-10052.DWG, \SIBCDON-11-10053.DWG, \SIBCDON-11-10054.DWG, \SIBCDON-11-10055.DWG, \SIBCDON-11-10056.DWG, \SIBCDON-11-10057.DWG, \SIBCDON-11-10058.DWG, \SIBCDON-11-10059.DWG, \SIBCDON-11-10060.DWG, \SIBCDON-11-10061.DWG, \SIBCDON-11-10062.DWG, \SIBCDON-11-10063.DWG, \SIBCDON-11-10064.DWG, \SIBCDON-11-10065.DWG, \SIBCDON-11-10066.DWG, \SIBCDON-11-10067.DWG, \SIBCDON-11-10068.DWG, \SIBCDON-11-10069.DWG, \SIBCDON-11-10070.DWG, \SIBCDON-11-10071.DWG, \SIBCDON-11-10072.DWG, \SIBCDON-11-10073.DWG, \SIBCDON-11-10074.DWG, \SIBCDON-11-10075.DWG, \SIBCDON-11-10076.DWG, \SIBCDON-11-10077.DWG, \SIBCDON-11-10078.DWG, \SIBCDON-11-10079.DWG, \SIBCDON-11-10080.DWG, \SIBCDON-11-10081.DWG, \SIBCDON-11-10082.DWG, \SIBCDON-11-10083.DWG, \SIBCDON-11-10084.DWG, \SIBCDON-11-10085.DWG, \SIBCDON-11-10086.DWG, \SIBCDON-11-10087.DWG, \SIBCDON-11-10088.DWG, \SIBCDON-11-10089.DWG, \SIBCDON-11-10090.DWG, \SIBCDON-11-10091.DWG, \SIBCDON-11-10092.DWG, \SIBCDON-11-10093.DWG, \SIBCDON-11-10094.DWG, \SIBCDON-11-10095.DWG, \SIBCDON-11-10096.DWG, \SIBCDON-11-10097.DWG, \SIBCDON-11-10098.DWG, \SIBCDON-11-10099.DWG, \SIBCDON-11-10100.DWG

FILE NAME =	USER NAME = #USER#	DESIGNED - JB	REVISED -	STATE OF ILLINOIS DEPARTMENT OF TRANSPORTATION	PROPOSED RELOCATED IL ROUTE 3 TYPICAL SECTIONS			F.A.P. RTE. 998	SECTION 82-2-1K	COUNTY ST. CLAIR	TOTAL SHEETS 353	SHEET NO. 17			
#FILE#		DRAWN - JB	REVISED -					SCALE: N.T.S.	SHEET NO. 5 OF 9 SHEETS	STA. TO STA.	FED. ROAD DIST. NO.	ILLINOIS	FED. AID PROJECT	CONTRACT NO. 76E06	
PLOT SCALE = #SCALE#		CHECKED - ACL	REVISED -												
PLOT DATE = #DATE#		DATE - 10/21/11	REVISED -												
								CONTRACT NO. 76E06							

