

NO BORDER, BLACK ON WHITE:
[C30] C 520 SPACING; [250W] C; [480V] C.

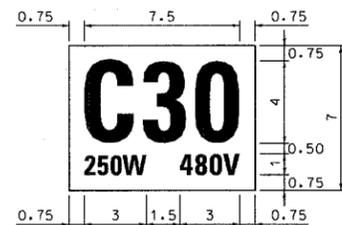

THE CONTRACTOR SHALL FURNISH AND INSTALL A LIGHT POLE IDENTIFICATION OF EACH NEW LIGHT POLE, AS SHOWN ABOVE, AND CONFORMING TO THE REQUIREMENTS OF SECTION 830 AND ARTICLE 1069.06 OF THE STANDARD SPECIFICATIONS.

THE LIGHT POLE IDENTIFICATION PANEL SHALL BE MOUNTED, APPROXIMATELY 7 FT. ABOVE THE ADJACENT PAVEMENT GRADE, VISIBLE TO APPROACHING TRAFFIC.

LIGHT POLE IDENTIFICATION

N.T.S.

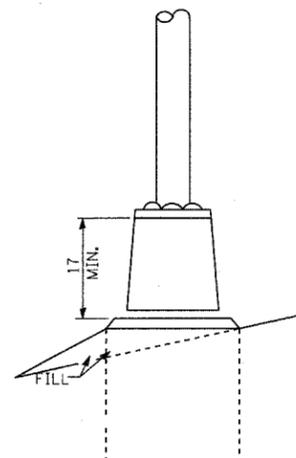

TRANSFORMER BASE MOUNTED ON FOUNDATION DETAIL

N.T.S.

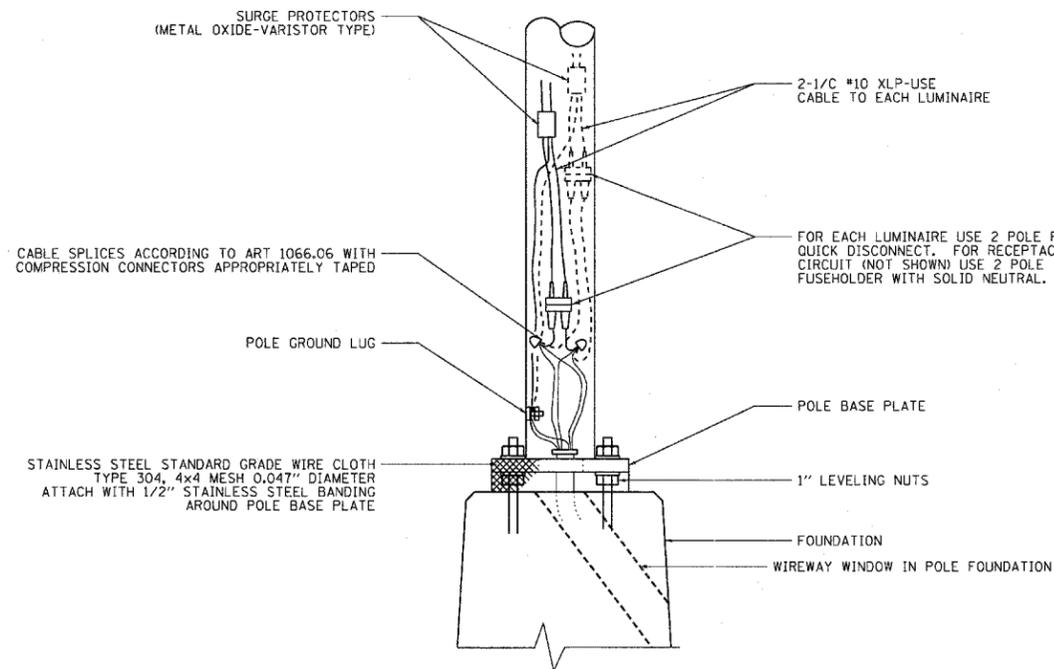

POLE BASE WIRING DETAIL

N.T.S.

- NOTES:
1. ALL TAPED SPLICES SHALL USE 2 LAYERS OF ELECTRIC TAPE AND 3 LAYERS OF RUBBER TAPE AS REQUIRED BY THE STANDARD SPECIFICATIONS. COAT THE FINISHED TAPED SPLICE WITH BONDING COMPOUND.
 2. ALL CABLE SPLICES SHALL BE TAPED UNLESS ANOTHER METHOD HAS BEEN SPECIFICALLY APPROVED BY THE ENGINEER.

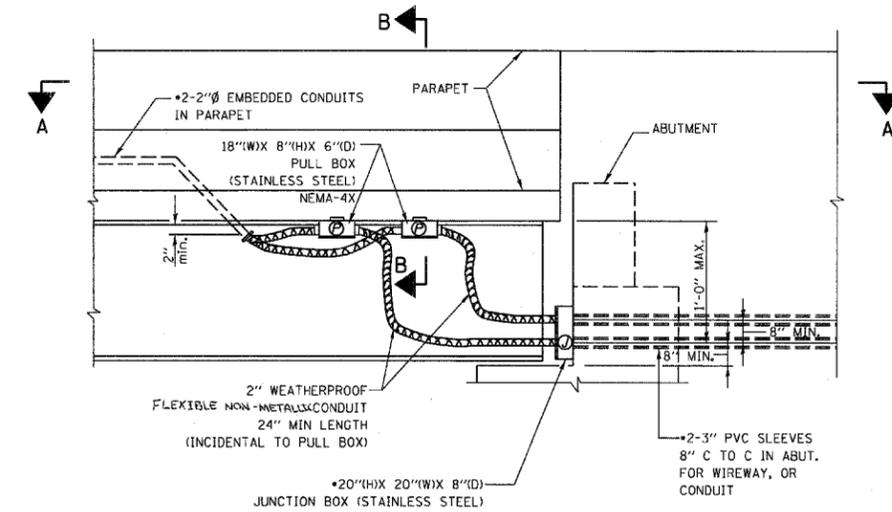

SECTION AT CONVENTIONAL ABUTMENTS

BY OTHERS
N.T.S.

NOTE: PULLBOX TO BE PAID FOR WITH CORRESPONDING JUNCTION BOX PAY ITEM (TYP.)

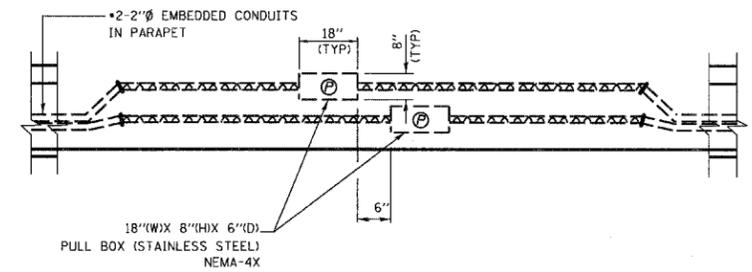

VIEW A-A

N.T.S.

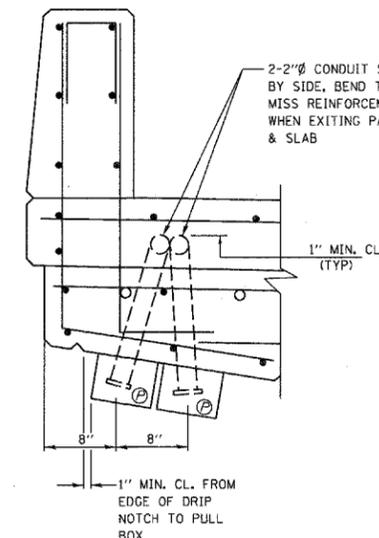

VIEW B-B (WITH SIDEWALK)

N.T.S.

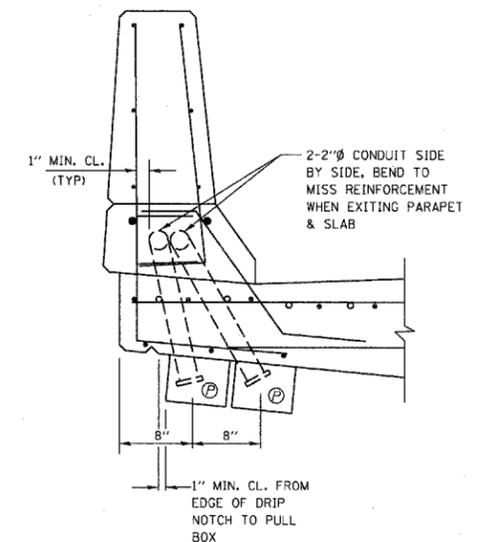

VIEW B-B (WITHOUT SIDEWALK)

N.T.S.

**STATE OF ILLINOIS
DEPARTMENT OF TRANSPORTATION**
I-TO CONNECTION

LIGHTING DETAILS

FILE NAME =	USER NAME = #USER#	DESIGNED - AAB	REVISED -
#FILEL#		DRAWN - MNR	REVISED -
	PLOT SCALE = #SCALE#	CHECKED - JL	REVISED -
	PLOT DATE = #DATE#	DATE - 10/21/11	REVISED -

SCALE:	SHEET NO. 1 OF 1 SHEETS	STA.	TO STA.
--------	-------------------------	------	---------

F.A.P. RTE. 998	SECTION 82-2-1K	COUNTY ST. CLAIR	TOTAL SHEETS 353	SHEET NO. 267
FED. ROAD DIST. NO.		ILLINOIS FED. AID PROJECT		

CONTRACT NO. 76E06