

TYPICAL SECTION

STA. 510+00.00 TO STA 510+30.21
 STA. 514+44.99 TO STA 515+80.00

LEGEND

- ① EXISTING PCC PAVEMENT, 9-6-9
- ② EXISTING HMA WIDENING' 8"
- ③ EXISTING HMA SURFACE, 5"±
- ④ EXISTING HMA SHOULDERS, 6"
- ⑤ EXISTING AGG. SHOULDERS, 6"
- ⑥ EXISTING BRIDGE APPROACH PAVEMENT
- ⑦ PROPOSED BASE COURSE WIDENING, 9"

MIX REQUIREMENT CHART

MIXTURE USE	BINDER/BASE COURSE
AC/PG	PG 64-22
RAP % (MAX)	SEE SPEC.
DESIGN AIR Voids	4.0% @ Ndes=70
MIX COMPOSITION	
(GRADATION MIXTURE)	IL 19.0
FRICTION AGG	MIXTURE "B"

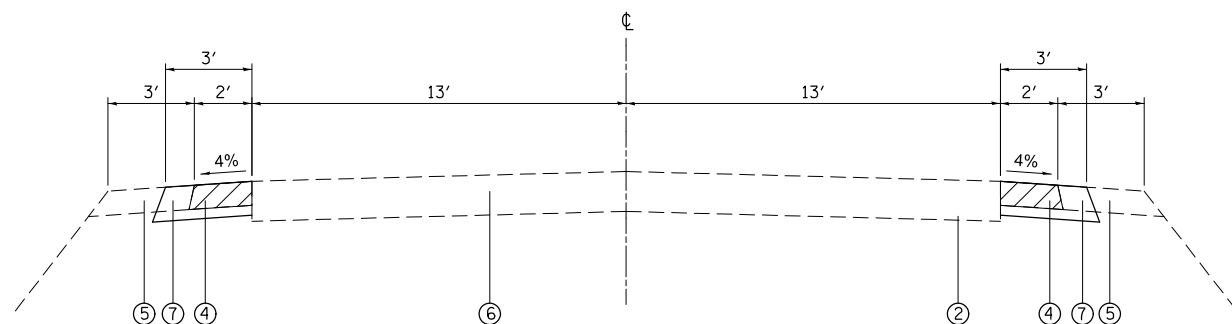

TYPICAL SECTION

STA. 510+30.21 TO STA 511+30.21
 STA. 514+44.99 TO STA 514+44.49

DENOTES PAVED SHOULDER REMOVAL

FILE NAME =	USER NAME = muehfeldac	DESIGNED - ACM	REVISED -
et:\pw\work\p\dot\muehfeldac\8260835\876e99-sh1-Typical.dgn		DRAWN - ACM	REVISED -
	PLOT SCALE = 40.0000' / in.	CHECKED -	REVISED -
	PLOT DATE = 10/31/2011	DATE -	REVISED -

STATE OF ILLINOIS
 DEPARTMENT OF TRANSPORTATION

PLAN AND TYPICAL SECTION SHEET

SCALE: 20' SHEET NO. 1 OF 1 SHEETS STA. 510+00.00 TO STA. 515+80.00

F.A.P. RTE.	SECTION	COUNTY	TOTAL SHEETS	SHEET NO.
805	125BR-2	ST. CLAIR	17	4
CONTRACT NO. 76E99			ILLINOIS FED. AID PROJECT	