

SECTION A-A

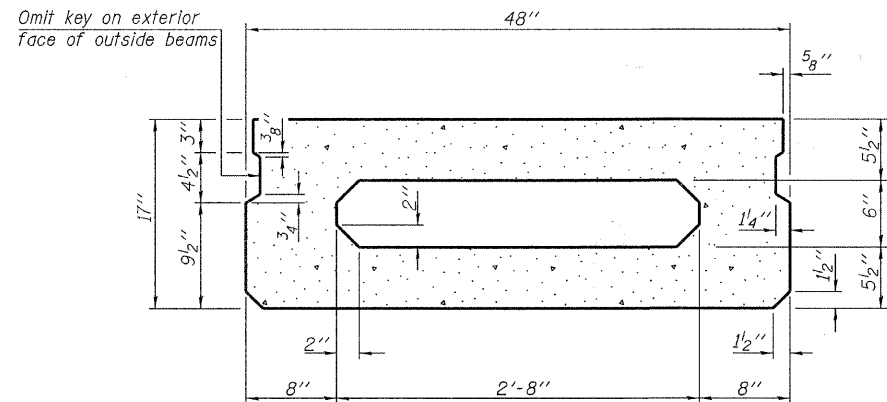

SECTION B-B
(Showing dimensions)

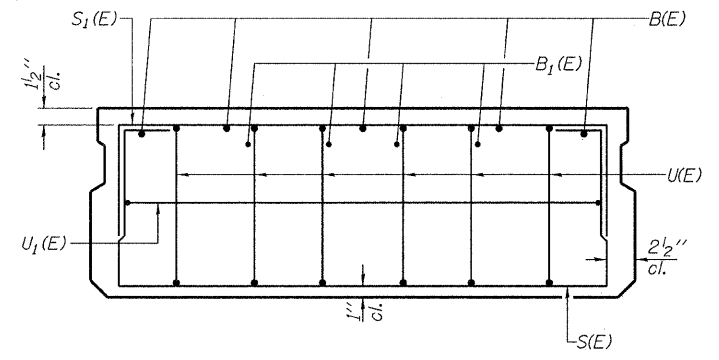

VIEW C-C

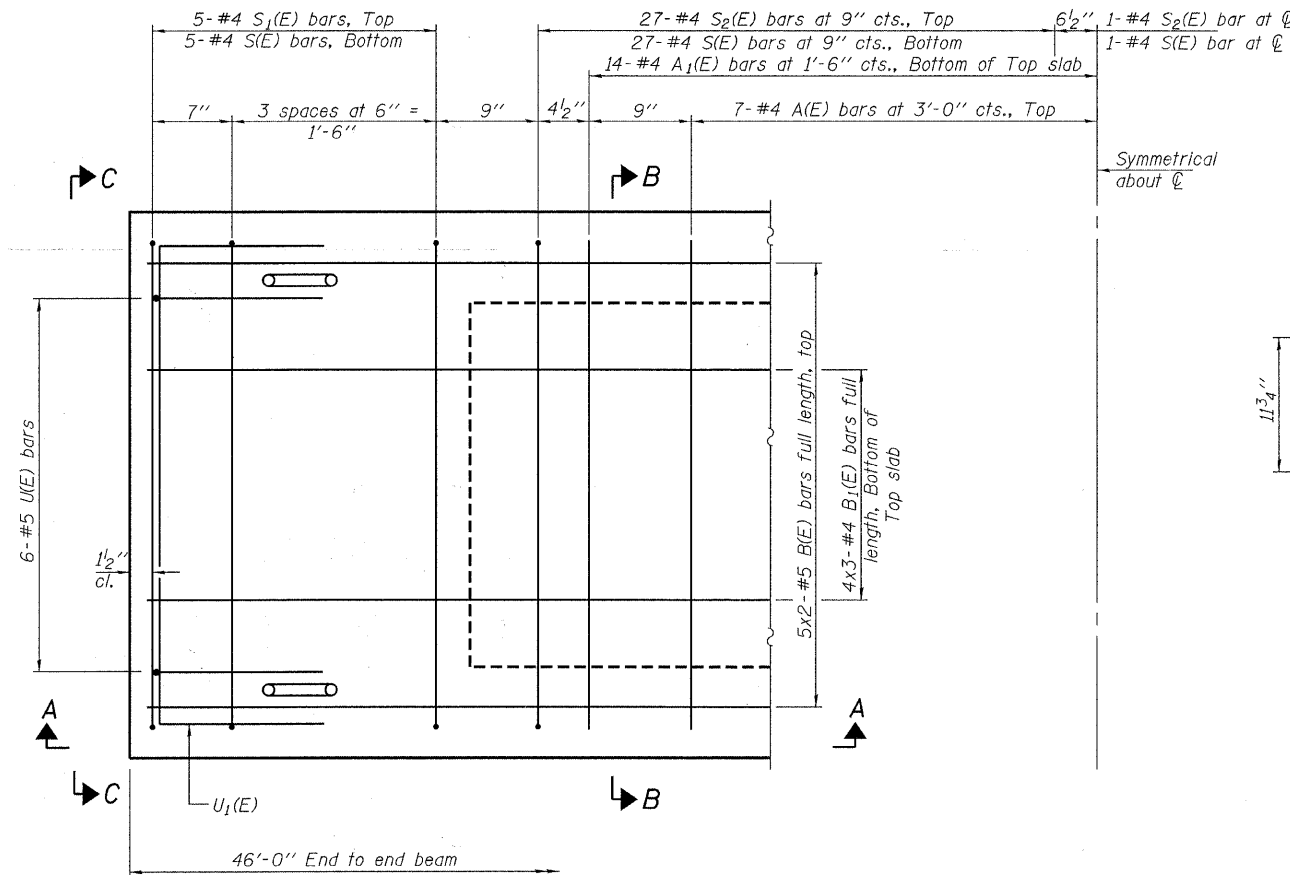

PLAN VIEW

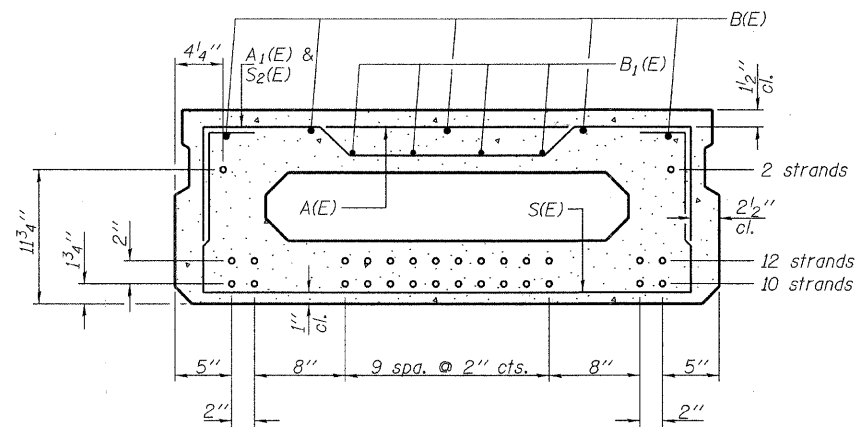

SECTION B-B
(Showing reinforcement and permissible strand locations)

Note: Place the number of strands specified in each row symmetrically about the centerline of beam in the permissible strand locations shown.

BAR LIST
ONE BEAM ONLY
(For information only)

Bar	No.	Size	Length	Shape
A(E)	14	#4	3'-7"	—
A1(E)	28	#4	3'-10"	—
B(E)	10	#5	24'-2"	—
B1(E)	12	#4	16'-7"	—
S(E)	65	#4	6'-9"	—
S1(E)	10	#4	5'-3"	—
S2(E)	55	#4	5'-6"	—
U(E)	12	#5	3'-8"	—
U1(E)	2	#4	6'-0"	—

Note: See sheet 3 & 4 of 9 for additional details and Bill of Material.

MINIMUM BAR LAP
#4 bar = 2'-0"
#5 bar = 2'-6"

Notes:
Spacing of S(E) and S2(E) bars may be adjusted up to 4" in the immediate area of the transverse tie diaphragms to miss the block outs for the transverse ties.
Bars indicated thus 5x2-#5 etc. indicates 5 lines of bars with 2 lengths per line.

PD-1748-0 7-1-10

FILE NAME = 120098-sht-bridge.dgn	USER NAME =	DESIGNED - A.S.L.	REVISED -
HAMPTON, LENZINI AND RENWICK, INC. 3008 STEVENSON DRIVE, SUITE 201 SPRINGFIELD, ILLINOIS 62763		CHECKED - S.W.M.	REVISED -
ILLINOIS PROFESSIONAL DESIGN FIRM L8 / PE / SE CORP. 183 800998	PLOT SCALE =	DRAWN - D.A.B.	REVISED -
	PLOT DATE = 10/27/2011	CHECKED - S.W.M.	REVISED -

STATE OF ILLINOIS
EFFINGHAM COUNTY HIGHWAY DEPARTMENT

17" x 48" PPC DECK BEAM
STRUCTURE NO. 025-3323

SHEET NO. 2 OF 8 SHEETS

T.R.	SECTION	COUNTY	TOTAL SHEETS	SHEET NO.
266	10-13112-00-BR	EFFINGHAM	21	15
UNION ROAD DISTRICT			CONTRACT NO. 95669	
ILLINOIS FED. AID PROJECT				