

CONSTRUCTION PLANS

FOR

ROCHELLE MUNICIPAL AIRPORT MAJOR THOMAS F. KORITZ FIELD

ROCHELLE, OGLE COUNTY, ILLINOIS

CONSTRUCT ELECTRICAL VAULT

SCOPE OF WORK:

BASE BID: THIS WORK SHALL CONSIST OF THE REMOVAL OF THE EXISTING ELECTRICAL VAULT EQUIPMENT LOCATED IN THE TERMINAL BUILDING HANGAR AND REPLACING IT WITH A NEW ELECTRICAL VAULT WITH ASSOCIATED EQUIPMENT, HANDHOLES, DUCTS, AND CABLING. THE EXISTING CONSTANT CURRENT REGULATOR WILL BE RELOCATED TO THE NEW VAULT FOR USE AS A BACKUP UNIT.

ADDITIVE ALTERNATE NO. 1: THIS WORK SHALL INCLUDE THE INSTALLATION OF A PORTABLE GENERATOR QUICK CONNECT AND AN AUTOMATIC TRANSFER SWITCH AT THE NEW ELECTRICAL VAULT WITH ASSOCIATED CONDUITS AND CABLING.

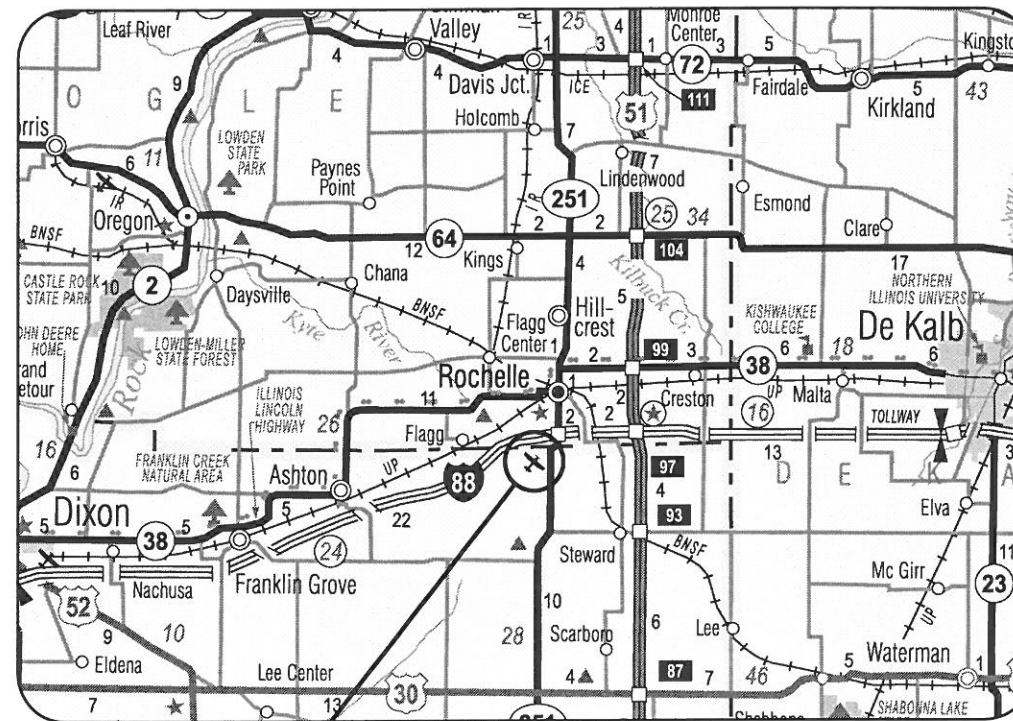

ROCHELLE MUNICIPAL AIRPORT LOCATION

ILL. PROJ.: RPJ-4136
A.I.P. PROJ.: 3-17-0087-B14
LATITUDE: 41° 53' 35"
LONGITUDE: 89° 04' 42"
ELEVATION: 781.00' M.S.L.
DATE: NOV. 22, 2011

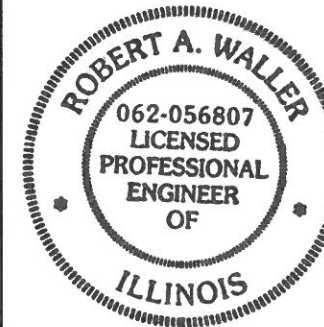

PLANS PREPARED BY:

HANSON
Hanson Professional Services Inc.
ELECTRICAL ENGINEER

Submitted by: *Kevin N. Lightfoot* ENG'R

Date Submitted: 11/23/2011

Lics. Exp. Date: November 30, 2013

PLANS PREPARED BY:

HANSON
Hanson Professional Services Inc.
CIVIL ENGINEER

Submitted by: *Robert A. Waller* ENG'R

Date Submitted: 11/23/2011

Lics. Exp. Date: November 30, 2013

ROCHELLE MUNICIPAL AIRPORT

Approved: *Donald A. Ernst* AIRPORT MANAGER

Date: 11/22/11

DATE	REVISION						
ROCHELLE MUNICIPAL AIRPORT MAJOR THOMAS F. KORITZ FIELD ROCHELLE, ILLINOIS							
ILL. PROJ.: RPJ-4136 A.I.P. PROJ.: 3-17-0087-B14							
Hanson Project No.	10A0139D	Title	AS SHOWN	Scale	11/22/11	LAYOUT	JFC 10/21/11
Drawn		Checked		Reviewed	CAH/KNL	10/21/11	
HANSON Hanson Professional Services Inc. 1525 South Sixth Street Springfield, Illinois 62703-2886 Ph: (217) 788-2450 Fax: (217) 788-2503 www.hanson-inc.com Offices Nationwide							
CONSTRUCT ELECTRICAL VAULT				COVER SHEET			
1							
1 of 24 sheets							

NOV 23, 2011 11:55 AM WALLER0723
p:\epi-sv-306\hanson\dem\hanson_projects\Documents\10a0139d\10a0139d\CAD\Airport\Sheet\B-101-COV

SUMMARY OF QUANTITIES – BASE BID

ITEM NO.	DESCRIPTION	UNIT	TOTAL QUANTITIES	AS BUILT QUANTITIES
AR108158	1/C #8 5 KV UG CABLE IN UD	LF	900	
AR108654	3/C #4 600V UG CABLE IN UD	LF	950	
AR108656	3/C #6 600V UG CABLE IN UD	LF	950	
AR108658	3/C #8 600V UG CABLE IN UD	LF	1,760	
AR109110	ERECT PREFABRICATED VAULT	LS	1	
AR109200	INSTALL ELECTRICAL EQUIPMENT	LS	1	
AR109902	REMOVE ELECTRICAL EQUIPMENT	LS	1	
AR110014	4" DIRECTIONAL BORE	LF	460	
AR110504	4-WAY, CONCRETE ENCASED DUCT	LF	140	
AR110610	ELECTRICAL HANDHOLE	EA	4	
AR125565	SPLICE CAN	EA	1	
AR150510	ENGINEER'S FIELD OFFICE	LS	1	

SUMMARY OF QUANTITIES – ADDITIVE ALTERNATE NO. 1

ITEM NO.	DESCRIPTION	UNIT	TOTAL QUANTITIES	AS BUILT QUANTITIES
AS109800	GENERATOR SYSTEM	LS	1	

INDEX TO SHEETS

SHEET NO.	DESCRIPTION
1	COVER SHEET
2	SUMMARY OF QUANTITIES AND INDEX OF SHEETS
3	PROPOSED SAFETY PLAN
4	PROPOSED ELECTRICAL SITE PLAN
5	ELECTRICAL DETAILS (SHEET 1)
6	ELECTRICAL DETAILS (SHEET 2)
7	ELECTRICAL NOTES (SHEET 1)
8	ELECTRICAL NOTES (SHEET 2)
9	ELECTRICAL LEGEND AND ABBREVIATIONS
10	EXISTING AIRPORT VAULT EQUIPMENT ELEVATION
11	EXISTING ELECTRICAL ONE-LINE DIAGRAM
12	PROPOSED AIRPORT VAULT EQUIPMENT PLAN
13	PROPOSED VAULT LIGHTING AND RECEPTACLE PLAN
14	PROPOSED AIRPORT VAULT ELEVATIONS (SHEET 1)
15	PROPOSED AIRPORT VAULT ELEVATIONS (SHEET 2)
16	PROPOSED ELECTRICAL ONE-LINE FOR VAULT AND AIRFIELD
17	VAULT LIGHTING CONTACTOR SCHEMATIC
18	LIGHTING CONTACTOR PANEL DETAIL
19	AIRFIELD LIGHTING CONTROL WIRING SCHEMATIC
20	HIGH VOLTAGE WIRING SCHEMATIC FOR RUNWAY
21	LEGEND PLATE SCHEDULES
22	VAULT GROUND BUS RISER
23	GROUNDING DETAILS
24	GROUNDING NOTES

REVISION	DATE

ROCHELLE MUNICIPAL AIRPORT
 MAJOR THOMAS F. KORITZ FIELD
 ROCHELLE, ILLINOIS

IL PROJ.: RPJ-4136 A.I.P. PROJ.: 3-17-0087-B14

Hanson Project No. 10A0139D	AS SHOWN	11/22/11	10/21/11
Filename	Scale	Date	LAYOUT
			JFC
			JFC
			CAH/KNL
			10/21/11
			REVIEWED



© Copyright Hanson Professional Services Inc. 2011
Hanson Professional Services Inc.
 1525 South Sixth Street
 Springfield, Illinois 62703-2886
 Ph: (217) 788-2450 Fax: (217) 788-2503
 www.hanson-inc.com
 Offices Nationwide

CONSTRUCT
 ELECTRICAL VAULT

SUMMARY OF QUANTITIES
 AND INDEX OF SHEETS

NOV 23, 2011 12:05 PM WALLE00723
 p:\s\spi-svr306\hanson\dom\hanson_projects\Documents\10A0139D\10A0139D\CAD\Airport_Sheet\R-002-FLP

UTILITY NOTE

THE LOCATION, SIZE, AND TYPE OF MATERIAL OF EXISTING UNDERGROUND AND/OR ABOVEGROUND UTILITIES INDICATED ON THE PLANS ARE NOT REPRESENTED AS BEING ACCURATE, SUFFICIENT OR COMPLETE. NEITHER THE OWNER NOR THE ENGINEER ASSUMES ANY RESPONSIBILITY WHATEVER IN RESPECT TO THE ACCURACY, COMPLETENESS, OR SUFFICIENCY OF THE INFORMATION. THERE IS NO GUARANTEE, EITHER EXPRESSED OR IMPLIED, THAT THE LOCATIONS, SIZE AND TYPE OF MATERIAL OF EXISTING UNDERGROUND UTILITIES INDICATED ARE REPRESENTATIVE OF THOSE TO BE ENCOUNTERED IN THE CONSTRUCTION. IT SHALL BE THE CONTRACTOR'S RESPONSIBILITY TO DETERMINE THE ACTUAL LOCATION OF ALL SUCH FACILITIES, INCLUDING SERVICE CONNECTIONS TO UNDERGROUND UTILITIES. PRIOR TO CONSTRUCTION, THE CONTRACTOR SHALL NOTIFY THE UTILITY COMPANIES OF HIS OPERATIONAL PLANS AND SHALL OBTAIN FROM THE RESPECTIVE UTILITY COMPANIES DETAILED INFORMATION AND ASSISTANCE RELATIVE TO THE LOCATION OF THEIR FACILITIES AND THE WORKING SCHEDULE OF THE COMPANIES FOR REMOVAL OR ADJUSTMENT WHERE REQUIRED. IN THE EVENT AN UNEXPECTED UTILITY INTERFERENCE IS ENCOUNTERED DURING CONSTRUCTION, THE CONTRACTOR SHALL IMMEDIATELY NOTIFY THE UTILITY COMPANY OF JURISDICTION. THE OWNER'S REPRESENTATIVE AND/OR THE RESIDENT ENGINEER SHALL ALSO BE IMMEDIATELY NOTIFIED. ANY DAMAGE TO SUCH MAINS AND SERVICES SHALL BE RESTORED TO SERVICE AT ONCE AND PAID FOR BY THE CONTRACTOR AT NO ADDITIONAL COST TO THE CONTRACT. ALL UTILITY CABLES AND LINES SHALL BE LOCATED BY THE RESPECTIVE UTILITY. **CONTACT JULIE (JOINT UTILITY LOCATION INFORMATION FOR EXCAVATORS) FOR UTILITY INFORMATION, PHONE: 1-800-892-0123.** CONTACT THE FAA (FEDERAL AVIATION ADMINISTRATION) FOR ASSISTANCE IN LOCATING FAA CABLES AND UTILITIES. LOCATION OF FAA POWER, CONTROL, AND COMMUNICATION CABLES SHALL BE COORDINATED WITH AND/OR LOCATED BY THE FAA. ALSO CONTACT AIRPORT DIRECTOR/MANAGER AND AIRPORT PERSONNEL FOR ASSISTANCE IN LOCATING UNDERGROUND AIRPORT CABLES AND/OR UTILITIES. ALSO COORDINATE WORK WITH ALL ABOVEGROUND UTILITIES.

HAUL ROUTE AND VEHICLE PARKING

THE CONTRACTOR WILL USE THE DESIGNATED HAUL ROUTE AND MATERIAL/EQUIPMENT STORAGE AREA AS SHOWN ON THIS SHEET. THE PROPOSED STORAGE AREA WILL BE 50'X75'. THE CONTRACTOR WILL BE REQUIRED TO MAINTAIN THE PROPOSED HAUL ROUTE AND STORAGE AREA THROUGHOUT THE COURSE OF THE PROJECT. ANY AREAS DAMAGED OUTSIDE OF THESE AREAS WILL BE REPAIRED BY THE CONTRACTOR AND AT THE CONTRACTOR'S OWN EXPENSE. AT THE CONCLUSION OF THE PROJECT THE CONTRACTOR WILL GRADE, FERTILIZE, SEED AND MULCH THE HAUL ROUTE AND STORAGE AREA AS NEEDED TO RESTORE IT TO ITS ORIGINAL STATE. RESTORATION OF THE HAUL ROUTE AND STORAGE AREA WILL BE CONSIDERED INCIDENTAL TO THE PROJECT AND NO ADDITIONAL COMPENSATION WILL BE ALLOWED. PERSONAL VEHICLES MAY UTILIZE THE ADJACENT AIRPORT PARKING AREA AT THE DISCRETION OF AIRPORT MANAGEMENT.

CONTRACTOR RESPONSIBILITIES

THE CONTRACTOR AND HIS EMPLOYEES WILL BE RESTRICTED TO THE WORK AREA AND ALL OTHER AREAS OF THE AIRPORT ARE "OFF LIMITS" TO THEM.

THE CONTRACTOR SHALL KEEP THE ONE RUNWAY OPEN AT ALL TIMES AND SHALL ASSIST IN MAINTAINING CONTINUOUS TAXIWAY ACCESS TO ALL HANGARS AND ADMINISTRATIVE AREAS.





ALL WORK PERFORMED SHALL BE DONE IN A ORDERLY AND EFFECTIVE MANNER TO MINIMIZE RUNWAY AND TAXIWAY CLOSURES AS DESCRIBED ON THIS SHEET. NO RUNWAY OR TAXIWAY SHALL BE CLOSED OVERNIGHT.

NO TRENCHES OR HOLES WILL REMAIN OPEN OVERNIGHT WITHOUT SIGNAGE, BARRICADES, AND OTHER SAFETY MEASURES IN PLACE TO IDENTIFY THE AREA. THE ADEQUACY OF THE SAFETY MEASURES SHALL BE AT THE DISCRETION OF THE RESIDENT PROJECT REPRESENTATIVE (CONSULTANT) AND THE AIRPORT MANAGEMENT. SAID MEASURES SHALL BE CONSIDERED INCIDENTAL TO THE CONTRACT AND NO ADDITIONAL COMPENSATION ALLOWED.

BARRICADES AND TRAFFIC CONES

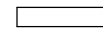
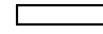
IT WILL BE THE CONTRACTOR'S RESPONSIBILITY TO PLACE AND MAINTAIN BARRICADES AND TRAFFIC CONES AS DIRECTED BY THE AIRPORT MANAGER. THE BARRICADES WILL BE EQUIPPED WITH RED FLASHING OR RED STEADY-BURN LIGHTS AND 20" SQUARE ORANGE FLAGS. THE BARRICADES, THEIR MAINTENANCE, PLACEMENT AND REMOVAL WILL BE CONSIDERED AS AN INCIDENTAL ITEM TO THE CONTRACT AND NO ADDITIONAL COMPENSATION WILL BE ALLOWED.

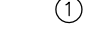
LEGEND

-  EXISTING IMPROVEMENTS
-  PROPOSED IMPROVEMENTS
-  EXISTING BUILDINGS
-  PROPOSED HAUL ROUTE AND EQUIPMENT PARKING AREA
-  PROPOSED BENCHMARK
-  PROPOSED BARRICADES OR TRAFFIC CONES

SCOPE OF WORK

THIS PROJECT CONSISTS OF **BASE BID:** THIS WORK SHALL CONSIST OF THE REMOVAL OF THE EXISTING ELECTRICAL VAULT EQUIPMENT LOCATED IN THE TERMINAL BUILDING HANGAR AND REPLACING IT WITH A NEW ELECTRICAL VAULT WITH ASSOCIATED EQUIPMENT, HANDHOLES, DUCTS, AND CABLING. THE EXISTING CONSTANT CURRENT REGULATOR WILL BE RELOCATED TO THE NEW VAULT FOR USE AS A BACKUP UNIT.

ADDITIVE ALTERNATE NO. 1: THIS WORK SHALL INCLUDE THE INSTALLATION OF A PORTABLE GENERATOR QUICK CONNECT AND AN AUTOMATIC TRANSFER SWITCH AT THE NEW ELECTRICAL VAULT WITH ASSOCIATED CONDUITS AND CABLING.

AIRPORT SECURITY NOTE

AIRPORT SECURITY WILL BE MAINTAINED AT ALL TIMES. THE CONTRACTOR WILL CLOSE AND LOCK THE EXISTING GATE IN THE HAUL ROUTE AT THE END OF EACH WORKING DAY.

CERTIFIED PAYROLLS

THE RESIDENT ENGINEER **CANNOT** FORWARD CONSTRUCTION REPORTS TO THE ILLINOIS DIVISION OF AERONAUTICS FOR PROCESSING UNTIL ALL **CERTIFIED PAYROLLS** FOR THE PERIOD HAVE BEEN RECEIVED.

AIRCRAFT OPERATION LINE

THE CONTRACTOR WILL LOCATE THIS LINE AT THE START OF CONSTRUCTION AND WILL PLACE A FRANGIBLE MARKER EVERY 150' ALONG IT. THIS LINE WILL BE THE LIMITS THAT ALL CONTRACTOR PERSONNEL MAY VENTURE WHEN A RUNWAY IS NOT CLOSED. THE CONTRACTOR WILL MAINTAIN THE MARKED LINE FOR RUNWAY THROUGHOUT THE PROJECT.

EROSION CONTROL

THIS PROJECT WILL DISTURB LESS THAN 1 ACRE OF LAND, THEREFORE NO N.P.D.E.S. PERMIT WILL BE REQUIRED.

HEIGHT OF CONSTRUCTION EQUIPMENT

THE MAXIMUM ANTICIPATED HEIGHT OF THE CONSTRUCTION EQUIPMENT WILL BE 70 FEET, WHICH IS EXPECTED TO BE A CRANE TO SET THE VAULT SHELTER. THE MAXIMUM ANTICIPATED HEIGHT OF THE CONSTRUCTION EQUIPMENT AT ALL OTHER LOCATIONS WILL BE 25 FEET, WHICH IS EXPECTED TO BE A CONCRETE TRUCK OR A LINE TRUCK. THE CRANE SHALL BE USED DURING THE DAYLIGHT HOURS AND VFR CONDITIONS ONLY AND SHALL BE LOWERED WHEN NOT IN USE, DURING THE HOURS BETWEEN SUNSET AND SUNRISE, AND/OR DURING IFR WEATHER CONDITIONS. WHEN IN USE, THE CRANE SHALL BE MARKED WITH THE 3' SQUARE CHECKERED FLAG.

MATERIAL CERTIFICATION

COMPLETED WORK **CANNOT** BE PLACED ON A CONSTRUCTION REPORT UNTIL ALL MATERIAL CERTIFICATIONS FOR THAT PAY ITEM HAVE BEEN RECEIVED, REVIEWED AND ACCEPTED BY THE RESIDENT ENGINEER.

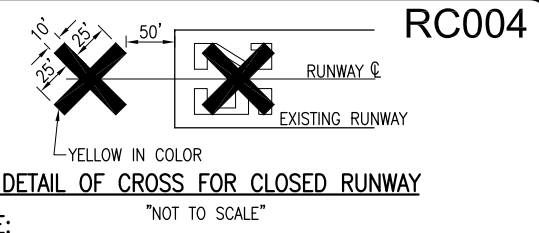

NOTE:

COST OF CONSTRUCTING, PLACING, MAINTAINING AND REMOVING CROSSES WILL BE CONSIDERED INCIDENTAL TO THE CONTRACT AND NO ADDITIONAL COMPENSATION WILL BE ALLOWED. THE CROSSES WILL BE YELLOW IN COLOR AND SHALL BE MADE OF A SUITABLE MATERIAL AS APPROVED BY THE AIRPORT MANAGER. THE CROSSES WILL BE PLACED OVER THE NUMERALS AND SECURED IN A MANNER APPROVED BY THE MANAGER. THE PROPOSED CROSSES WILL BE PLACED EACH DAY THE RUNWAY IS CLOSED AND REMOVED WHEN THE RUNWAY IS RE-OPENED. THE CONTRACTOR WILL BE RESPONSIBLE FOR THE PLACEMENT AND REMOVAL OF THE CROSSES. NO ADDITIONAL COMPENSATION WILL BE ALLOWED.

J.U.L.I.E. INFORMATION

COUNTY _____ OGLE
 CITY _____ ROCHELLE
 TOWNSHIP _____ FLAGG
 SECTION NO. _____ 35
 ADDRESS _____ MAJOR THOMAS F. KORITZ FIELD
 ROCHELLE MUNICIPAL AIRPORT
 ROUTE 251, SOUTH
 ROCHELLE, ILLINOIS 61068

CRITICAL POINT DATA

LATITUDE: 41° 53' 35"
 LONGITUDE: 89° 04' 34"
 ELEVATION: 774.00' M.S.L.

PROPOSED SAFETY PLAN

GENERAL - THE ROCHELLE MUNICIPAL AIRPORT IS COMPRISED OF ONE RUNWAY. THE PROPOSED CONSTRUCTION WILL NOT ANTICIPATED TO NECESSITATE CLOSING THE RUNWAY. HOWEVER, ANY TIME THE CONTRACTOR IS WORKING WITHIN 200' OF THE RUNWAY CENTERLINE THE RUNWAY WILL BE REQUIRED TO BE CLOSED. THE RUNWAY WILL BE CLOSED ONLY DURING THE CONSTRUCTION DAY. AT THE END OF EACH CONSTRUCTION DAY THE CONTRACTOR WILL SMOOTH GRADE ALL AREAS WITHIN THE SAFETY AREA TO THE SATISFACTION OF THE RESIDENT ENGINEER AND RE-OPEN THE RUNWAY. ALL WORK INCLUDED IN OPENING AND CLOSING THE RUNWAY WILL BE CONSIDERED INCIDENTAL TO THE PROJECT AND NO ADDITIONAL COMPENSATION WILL BE ALLOWED.

A TAXIWAY WILL REQUIRE TEMPORARY CLOSURE AT TIMES WHEN CONSTRUCTION IS TO OCCUR WITHIN 66 FEET FROM AN ACTIVE TAXIWAY CENTERLINE. THE TAXIWAY CLOSURE SHALL BE COORDINATED WITH THE AIRPORT. THE CONTRACTOR SHALL MINIMIZE TIMES OF CLOSURE IN AN EFFORT TO MAINTAIN ACCESS TO AIRPORT FACILITIES FOR TENANTS AND THE TRAVELING PUBLIC. THE CLOSURE SHALL CONSIST OF BARRICADES OR TRAFFIC CONES AT THE DISCRETION OF THE AIRPORT MANAGEMENT.

IDENTIFICATION - WHEN THE CONTRACTORS VEHICLES AND EQUIPMENT ARE ON THE AIRPORT THEY SHALL BE PROPERLY MARKED WITH THREE (3') FOOT SQUARE CHECKERED FLAGS (INTERNATIONAL ORANGE AND WHITE). THE CONTRACTOR WILL ALSO PROVIDE WORKERS WITH SOME TYPE OF TAG OR GARMENT TO IDENTIFY THE PERSON AS BEING PART OF THE CONSTRUCTION CREW.

RADIO CONTROL - THE CONTRACTOR WILL BE REQUIRED TO BE IN TWO-WAY RADIO CONTACT (122.80 Mhz.) WITH THE AIRPORT UNICOM. THIS WILL KEEP THE CONTRACTOR IN CONSTANT CONTACT WITH THE ROCHELLE MUNICIPAL AIRPORT AND ENABLE THE AIRPORT TO IMMEDIATELY CONTACT THE CONTRACTOR IN CASE OF AN AERONAUTIC EMERGENCY THAT WOULD REQUIRE ACTION BY THE CONTRACTOR AND/OR HIS PERSONNEL.

150-ENGINEER'S FIELD OFFICE NOTES

THE PROPOSED ENGINEER'S FIELD OFFICE WILL BE FURNISHED, MAINTAINED, AND REMOVED IN ACCORDANCE WITH ITEM AR150510 "ENGINEER'S FIELD OFFICE" AS STATED ON PAGE 49 OF THE STANDARD SPECIFICATIONS FOR CONSTRUCTION OF AIRPORTS NOV. 2, 2009.

THE LOCATION OF THE PROPOSED ENGINEER'S FIELD OFFICE WILL BE DETERMINED AT THE PRE-CONSTRUCTION MEETING.

THE ENGINEERING FIRM WILL MAKE PAYMENT FOR ALL LONG DISTANCE TELEPHONE CALLS IN EXCESS OF ONE HUNDRED DOLLARS (\$100.00) PER MONTH.

THE CONTRACTOR WILL FURNISH A WIRELESS PHONE TO THE RESIDENT ENGINEER FOR HIS EXCLUSIVE USE FOR THE DURATION OF THIS PROJECT. THE RESIDENT ENGINEER WILL USE THIS PHONE FOR PROJECT BUSINESS ONLY. THE CONTRACTOR WILL BE RESPONSIBLE FOR ALL CHARGES ASSOCIATED WITH THIS CELL PHONE.

THE PROPOSED ENGINEER'S FIELD OFFICE WILL BE PAID FOR UNDER ITEMS: AR150510 ENGINEER'S FIELD OFFICE _____ 1 L.S.

AS AN ALTERNATIVE, OFFICE SPACE ON THE AIRPORT FOR A FIELD OFFICE IS AVAILABLE WITHIN EXISTING CITY OWNED STRUCTURES. AT THE DISCRETION OF THE CONTRACTOR ARRANGEMENTS FOR USE OF THE SPACE (BY LEASE) MAY BE MADE BY CONTACTING DON ELLIOTT, AIRPORT MANAGER, AT 815-751-0591, OR EMAIL AT DELLIOTT@ROCHELLEIL.US.

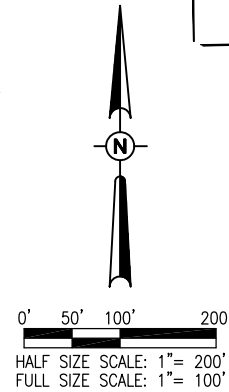
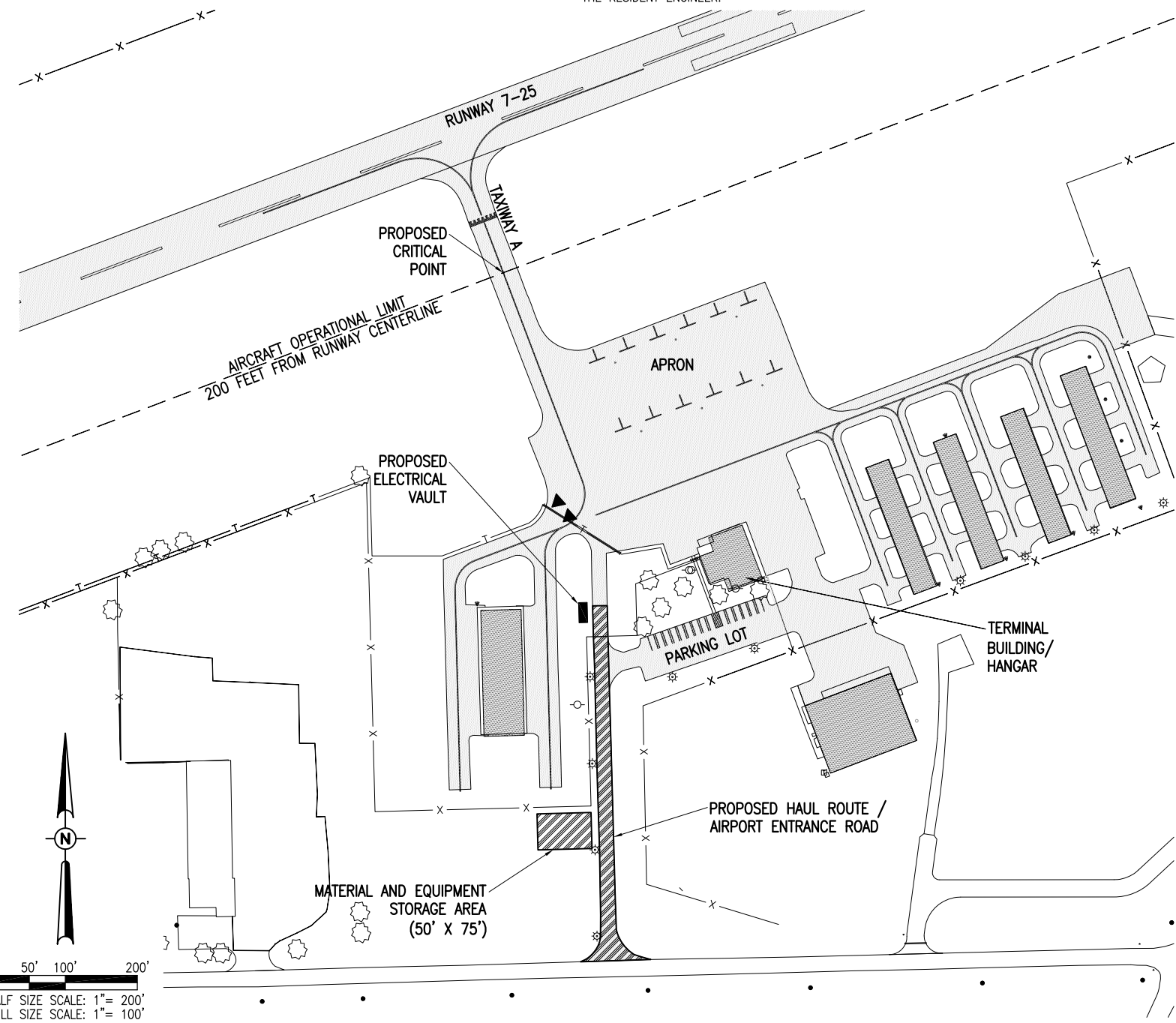

NOV 23, 2011 11:24 AM WALLE00723
 p:\sfr\svr306\hanson\Projects\Documents\10401390\10401390 CAD\Airport\Sheet\RC-003-SFY

REVISION	DATE

ROCHELLE MUNICIPAL AIRPORT
 MAJOR THOMAS F. KORITZ FIELD
 ROCHELLE, ILLINOIS

IL PROJ.: RPJ-4136
 A.I.P. PROJ.: 3-17-0087-B14

Hanson Project No. 10401390	11/22/11
Filename R-003-SFY.dwg	JFC
Scale AS SHOWN	JFC
Date 11/22/11	CAH/KNL
LAYOUT	10/21/11
DRAWN	10/21/11
REVIEWED	10/21/11

HANSON
 Professional Services Inc. 2011
 Hanson Professional Services Inc.
 1525 South Sixth Street
 Springfield, Illinois 62703-2886
 Ph: (217) 788-2450 Fax: (217) 788-2503
 www.hanson-inc.com
 Offices Nationwide

CONSTRUCT ELECTRICAL VAULT

PROPOSED SAFETY PLAN

GENERAL NOTES

- SEE "PROPOSED AIRPORT VAULT EQUIPMENT PLAN" FOR EQUIPMENT LAYOUTS AND CONDUIT ORIENTATIONS.
- FINAL ROUTING OF HIGH-VOLTAGE DUCTS AND LOW-VOLTAGE DUCTS SHALL BE INSTALLED WITH REQUIRED SEPARATION PER NATIONAL ELECTRICAL CODE, PROVIDE ADEQUATE SEPARATION (6 FT MIN.) OF HIGH VOLTAGE CONCRETE ENCASED DUCT FROM LOW VOLTAGE CONCRETE ENCASED DUCT TO ACCOMMODATE FUTURE DUCT EXTENSIONS AND TERMINATION IN MANHOLES.
- HOMERUN CABLES FOR A RESPECTIVE CIRCUIT THAT ARE INSTALLED IN CONDUIT OR DUCT SHALL BE RUN TOGETHER IN THE SAME RACEWAY OR DUCT.
- ANY AND ALL DISTURBED PAVEMENT AREAS WILL BE RESTORED TO ORIGINAL OR BETTER CONDITION. RESTORATION OF PAVEMENT AREAS DISTURBED DURING THE INSTALLATION OF THE PROPOSED DUCTS WILL BE INCIDENTAL TO THE RESPECTIVE PAY ITEM FOR WHICH THE DUCT IS INSTALLED. THE RESTORATION OF PAVEMENT WILL BE COMPLETED IN ACCORDANCE WITH ITEM 610 FOR SIDEWALKS AND CONCRETE PAVEMENT AND ITEM 401 FOR BITUMINOUS PAVEMENT, BUT WILL BE INCIDENTAL TO THE RESPECTIVE PAY ITEM FOR WHICH THE DUCT IS INSTALLED.
- COORDINATE DUCT & CABLE INSTALLATIONS WITH EXISTING FENCING, PAVEMENTS, SIDEWALKS, AND UTILITIES. RESTORE DISTURBED AREAS.
- THE PROPOSED ELECTRICAL VAULT WILL BE SITED AT THE COORDINATES BELOW. THE CONSULTANT WILL PROVIDE HORIZONTAL AND VERTICAL CONTROL TO THE CONTRACTOR FOR THE PROJECT AREA AT THE TIME OF CONSTRUCTION. FINISHED FLOOR ELEVATION OF THE PROPOSED VAULT SHALL BE 776.20'.

PROPOSED VAULT SITING COORDINATES			
LOCATION	NORTHING	EASTING	EXISTING GROUND ELEVATION
NW CORNER	1,904,979.98	2,593,635.72	774.0 ±
NE CORNER	1,904,980.31	2,593,647.72	774.7 ±
SE CORNER	1,904,952.32	2,593,648.50	774.7 ±
SW CORNER	1,904,951.99	2,593,636.50	774.0 ±

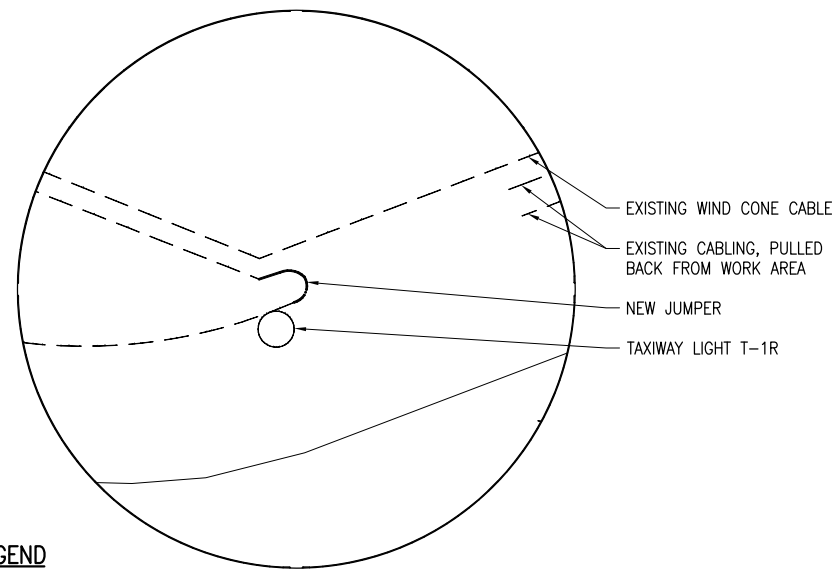

- LEGEND**
- T — EXISTING TELEPHONE
 - X — EXISTING FENCE
 - - - EXISTING UG ELECTRIC
 - — — EXISTING DUCT
 - — — PROPOSED DUCT
 - _{HH} PROPOSED ELECTRICAL HANDHOLE
 - _{SC} PROPOSED L-867 SPLICE CAN
 - — — PROPOSED 1-1/2 #8 AWG, FAA L-824, 5000 VOLT TYPE C UG CABLE IN UNIT DUCT
 - — — PROPOSED 3-1/2 #8 XLP-USE, 600V UG CABLE IN UNIT DUCT
 - — — PROPOSED 3-1/2 #6 XLP-USE, 600V UG CABLE IN UNIT DUCT
 - — — PROPOSED 3-1/2 #4 XLP-USE, 600V UG CABLE IN UNIT DUCT
 - EXISTING STAKE MOUNTED TAXIWAY LIGHT
 - ⊕ EXISTING BASE MOUNTED TAXIWAY LIGHT
 - ⊕ EXISTING BASE MOUNTED RUNWAY LIGHT

THE LOCATION, SIZE, AND TYPE OF MATERIAL OF EXISTING UNDERGROUND AND/OR ABOVEGROUND UTILITIES INDICATED ON THE PLANS ARE NOT REPRESENTED AS BEING ACCURATE, SUFFICIENT OR COMPLETE. NEITHER THE OWNER NOR THE ENGINEER ASSUMES ANY RESPONSIBILITY WHATEVER IN RESPECT TO THE ACCURACY, COMPLETENESS, OR SUFFICIENCY OF THE INFORMATION. THERE IS NO GUARANTEE, EITHER EXPRESSED OR IMPLIED, THAT THE LOCATIONS, SIZE AND TYPE OF MATERIAL OF EXISTING UNDERGROUND UTILITIES INDICATED ARE REPRESENTATIVE OF THOSE TO BE ENCOUNTERED IN THE CONSTRUCTION. IT SHALL BE THE CONTRACTOR'S RESPONSIBILITY TO DETERMINE THE ACTUAL LOCATION OF ALL SUCH FACILITIES, INCLUDING SERVICE CONNECTIONS TO UNDERGROUND UTILITIES. PRIOR TO CONSTRUCTION, THE CONTRACTOR SHALL NOTIFY THE UTILITY COMPANIES OF HIS OPERATIONAL PLANS AND SHALL OBTAIN FROM THE RESPECTIVE UTILITY COMPANIES DETAILED INFORMATION AND ASSISTANCE RELATIVE TO THE LOCATION OF THEIR FACILITIES AND THE WORKING SCHEDULE OF THE COMPANIES FOR REMOVAL OR ADJUSTMENT WHERE REQUIRED. IN THE EVENT AN UNEXPECTED UTILITY INTERFERENCE IS ENCOUNTERED DURING CONSTRUCTION, THE CONTRACTOR SHALL IMMEDIATELY NOTIFY THE UTILITY COMPANY OF JURISDICTION. THE OWNER'S REPRESENTATIVE AND/OR THE RESIDENT ENGINEER SHALL ALSO BE IMMEDIATELY NOTIFIED. ANY DAMAGE TO SUCH MAINS AND SERVICES SHALL BE RESTORED TO SERVICE AT ONCE AND PAID FOR BY THE CONTRACTOR AT NO ADDITIONAL COST TO THE CONTRACT.

ALL UTILITY CABLES AND LINES SHALL BE LOCATED BY THE RESPECTIVE UTILITY. CONTACT JULIE (JOINT UTILITY LOCATION INFORMATION FOR EXCAVATORS) FOR UTILITY INFORMATION, PHONE: 1-800-892-0123. CONTACT THE FAA (FEDERAL AVIATION ADMINISTRATION) FOR ASSISTANCE IN LOCATING FAA CABLES AND UTILITIES. LOCATION OF FAA POWER, CONTROL, AND COMMUNICATION CABLES SHALL BE COORDINATED WITH AND/OR LOCATED BY THE FAA. ALSO CONTACT AIRPORT DIRECTOR/MANAGER AND AIRPORT PERSONNEL FOR ASSISTANCE IN LOCATING UNDERGROUND AIRPORT CABLES AND/OR UTILITIES. ALSO COORDINATE WORK WITH ALL ABOVEGROUND UTILITIES.

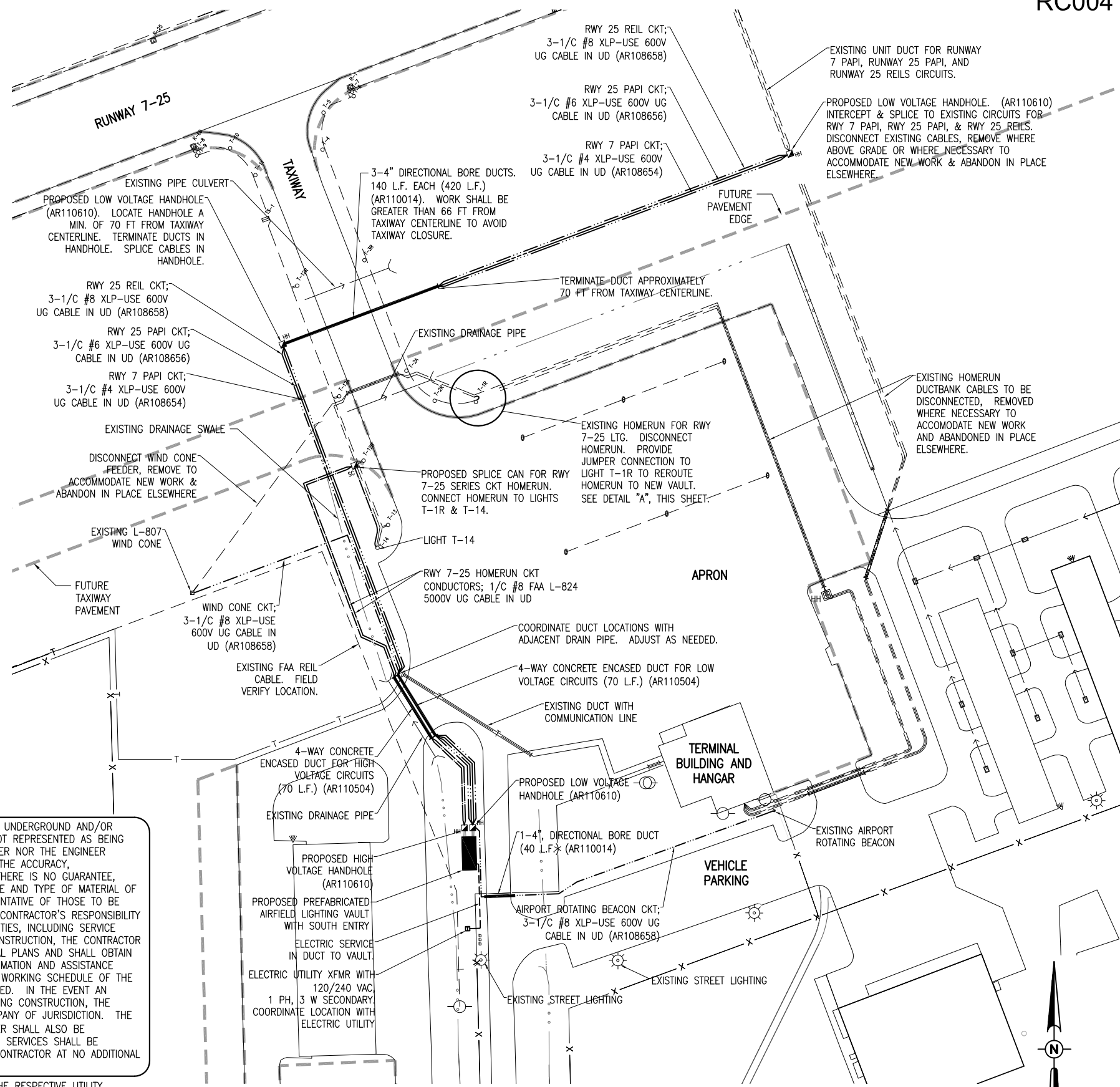

VAULT ELECTRICAL SITE PLAN

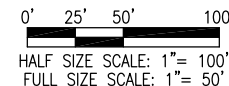

REVISION	DATE

ROCHELLE MUNICIPAL AIRPORT
MAJOR THOMAS F. KORITZ FIELD
ROCHELLE, ILLINOIS

Hanson Project No. 10A0139D	File Name: E-102-SIT.dwg	Scale: AS SHOWN	Date: 11/22/11
LAYOUT	JFC	JFC	10/21/11
DRAWN	JFC	JFC	10/21/11
REVIEWED	CHY/KNL	CHY/KNL	10/21/11

HANSON
Professional Services Inc. 2011
Hanson Professional Services Inc.
1525 South Sixth Street
Springfield, Illinois 62703-2886
Ph: (217) 788-2450 Fax: (217) 788-2503
www.hanson-inc.com
Offices Nationwide

CONSTRUCT
ELECTRICAL VAULT

PROPOSED ELECTRICAL
SITE PLAN

NOV 23, 2011 12:54 PM WALLE00723
p:\s\sp\svr306\hanson\dom\hanson\Projects\Documents\10A0139D\10A0139D\CAD\Airport\Sheet\E-102-SIT

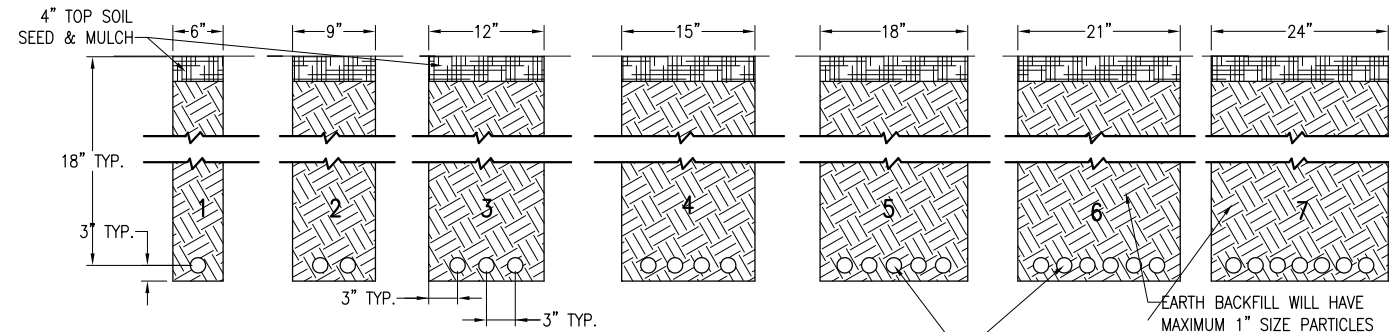

NOTES:
 DETAIL NUMBERS INDICATE NO. OF CABLES.
 TRENCHES WITH MORE THAN SEVEN CABLES SHALL BE INCREASED 3" IN WIDTH FOR EACH ADDITIONAL CABLE; IF SPECIFIED ON PLANS TWO PARALLEL TRENCHES MAY BE CONSTRUCTED.
 DEPTH OF TRENCHES SHALL BE AS SHOWN ABOVE UNLESS OTHERWISE SPECIFIED ON THE PLANS.
 ALL DISTURBED SURFACES SHALL BE RESTORED TO THEIR ORIGINAL CONDITION. COST IS INCIDENTAL TO TRENCH.

CABLE TRENCHES
 NOT TO SCALE

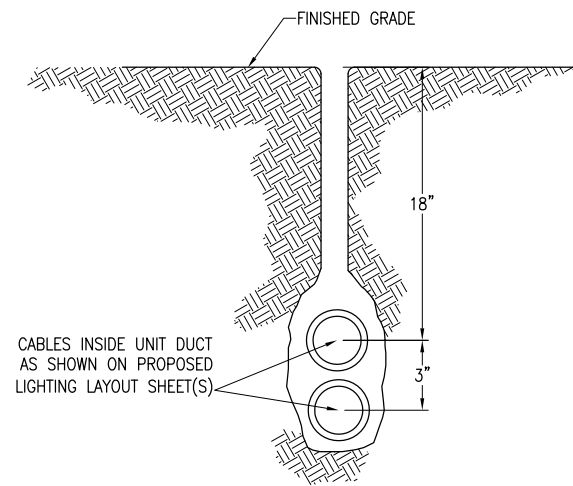

PLOWED CABLE
 NOT TO SCALE

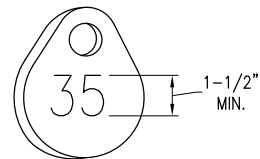

TAG DETAIL
 NOT TO SCALE

NOTE:
 AFFIX NON-CORROSIVE TAG TO FIXTURE FACING RUNWAY WITH SET SCREW, WIRE TIE, OR METAL BAND. NUMERALS SHALL BE ENGRAVED FOR PERMANENT READABILITY.

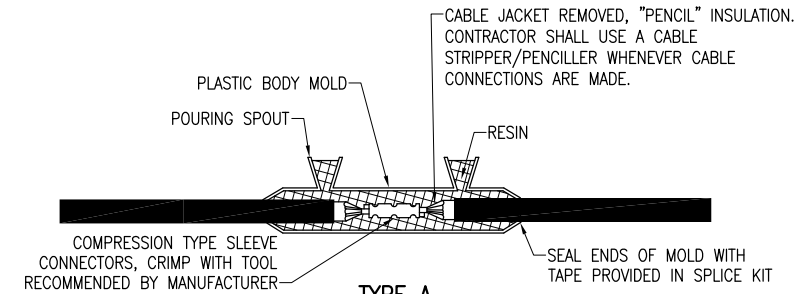

TYPE A

CONTINUOUS HEAT SHRINK TUBING PLACED OVER THE ENTIRE L-823 CONNECTOR(S) BOTH MALE AND FEMALE AT ALL 5KV JUNCTIONS. THE HEAT SHRINK TUBING SHALL BE APPROXIMATELY 18" IN LENGTH WITH 6 INCHES OF MASTIC ON BOTH ENDS AND VOID OF MASTIC IN MIDDLE OF TUBE RATED FOR 5KV.

FOR SPLICES IN LOW VOLTAGE CABLE (600V) HOMERUNS FOR EXTENSIONS TO EXISTING LOW VOLTAGE CABLES ONLY. TYPE A SPLICES SHALL BE MADE IN SPLICE CANS, HANDHOLES, MANHOLES, OR JUNCTIONS BOXES

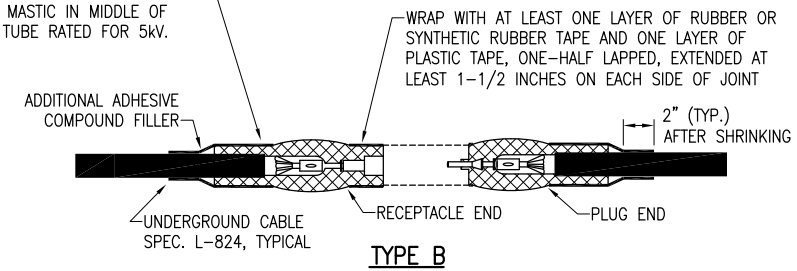

TYPE B

FOR SPLICES AT JUNCTION OF HOMERUN WITH LOOP CIRCUIT AND FOR SPLICES IN HOMERUNS TO EXISTING CABLES

HEAT SHRINKABLE TUBING WITH INTERNAL ADHESIVE. HEAT SHRINKABLE TUBING SHALL EXTEND FROM THE CABLE TO AT LEAST AN INCH PAST THE COMPLETED CONNECTION.

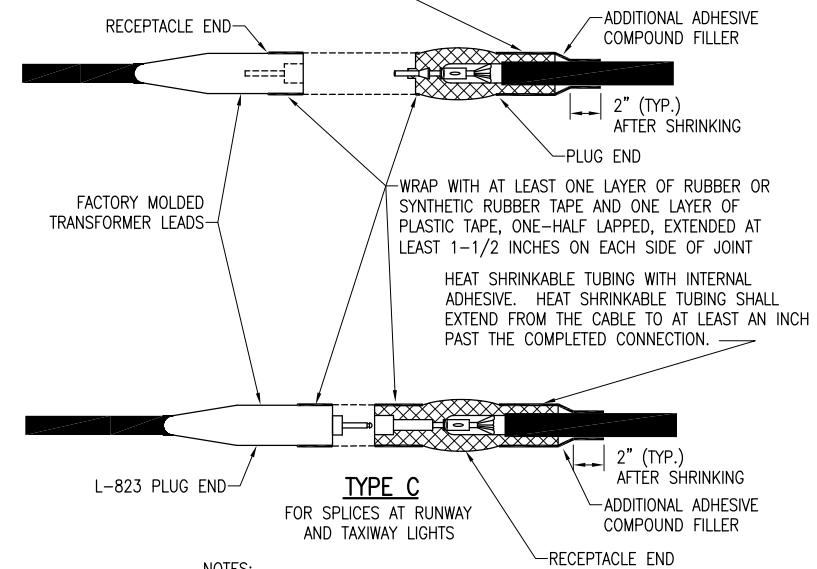

TYPE C

FOR SPLICES AT RUNWAY AND TAXIWAY LIGHTS

NOTES:
 SEE PROPOSED LIGHTING LAYOUT SHEET(S) FOR SPLICE TYPE.

INSIDE DIAMETER OF CONNECTOR SHALL PROPERLY MATCH THE OUTSIDE DIAMETER OF CABLE.

CABLE SPLICES
 (NOT TO SCALE)

REVISION	DATE

ROCHELLE MUNICIPAL AIRPORT
 MAJOR THOMAS F. KORITZ FIELD
 ROCHELLE, ILLINOIS
 I.L. PROJ.: RPJ-4136 A.I.P. PROJ.: 3-17-0087-B14

Hanson Project No. 10A0139D	10/21/11
Filename E-505.dwg	JFC
Scale AS SHOWN	JFC
Date 11/22/11	10/21/11
LAYOUT	10/21/11
DRAWN	10/21/11
REVIEWED CAH/KNL	10/21/11

HANSON
 © Copyright Hanson Professional Services Inc. 2011
 Hanson Professional Services Inc.
 1525 South Sixth Street
 Springfield, Illinois 62703-2886
 Ph: (217) 788-2450 Fax: (217) 788-2503
 www.hanson-inc.com
 Offices Nationwide

CONSTRUCT
 ELECTRICAL VAULT
 ELECTRICAL DETAILS
 (SHEET 1)

NOV 23, 2011 12:08 PM WALLE00723
 p:\s\sp\svr306\hanson\dom\hanson\Projects\Documents\10\Jobs\10A0139\10A0139D\CAD\Airport\Sheet\E-505-DTL

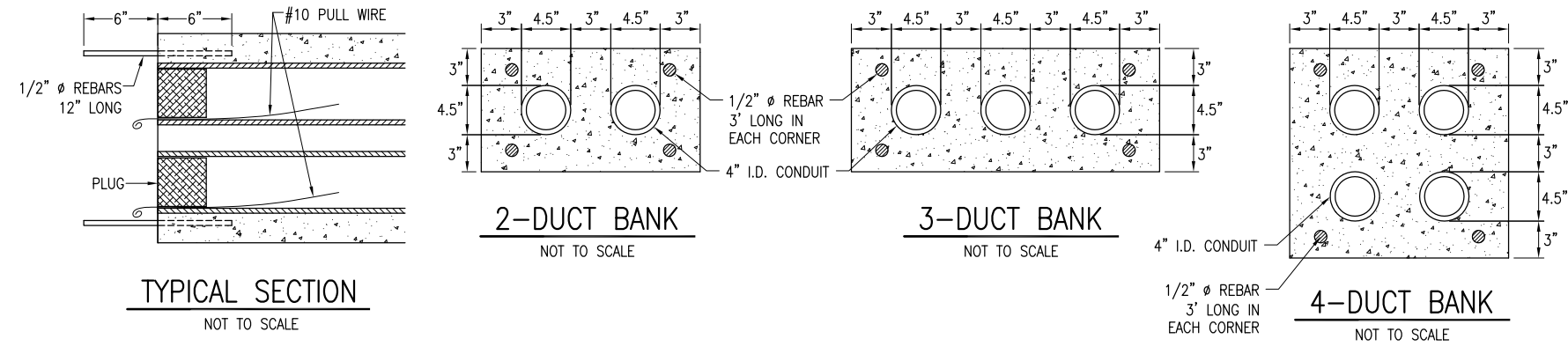

DUCT BANK NOTES:

- ALL DIMENSION ARE MINIMUM.
- INCLUDE DUCT SPACERS AS MANUFACTURED BY UNDERGROUND DEVICES INC., TO MAINTAIN PROPER SEPARATION OF CONDUITS.
- REBAR IS REQUIRED TO ACCOMMODATE FUTURE DUCT EXTENSIONS & INTERFACE AT DUCT BANK TERMINATIONS. CONCRETE ENCASED DUCT BANKS TERMINATING IN HANDHOLES REQUIRE REBAR AT TERMINATIONS.
- CONDUITS FOR CONCRETE ENCASED DUCT SHALL BE SCHEDULE 40 PVC CONFORMING TO ITEM 110.
- MINIMUM DEPTH OF TOP OF DUCT ENCASEMENT SHALL BE 18" BELOW FINISHED GRADE.
- HIGH VOLTAGE AND LOW VOLTAGE CIRCUITS SHALL NOT BE INSTALLED IN THE SAME RACEWAY, CONDUIT, DUCT, HANDHOLE, OR MANHOLE.
- HOMERUN CABLES FOR A RESPECTIVE CIRCUIT SHALL BE INSTALLED IN THE SAME RACEWAY OR DUCT.
- DUCT INTERFACE TO HANDHOLES OR MANHOLES WILL BE CONSIDERED INCIDENTAL TO THE RESPECTIVE DUCT PAY ITEM.

CABLE & DUCT MARKER NOTES:

- THE COST OF ALL TURF AND PAVEMENT DUCT MARKERS SHALL BE INCIDENTAL TO THE DUCT. THE COST OF ALL CABLE MARKERS SHALL BE INCIDENTAL TO THE CABLE.
- BITUMINOUS PAVEMENT DUCT MARKER AND CONCRETE DUCT MARKER TO BE PROVIDED AT EACH END OF EACH DUCT AS SHOWN ON THE LOCATION PLAN. FOR CONCRETE PAVEMENT, THE LETTER "D" SHALL BE IMPRESSED IN THE PAVEMENT INSTEAD OF THE MARKER. THE LETTER SHALL BE FORMED AS DESCRIBED IN NOTE 4.
- CABLE MARKERS SHALL BE PLACED AT CHANGES OF DIRECTION AND APPROXIMATELY EVERY 200' ALONG CABLE RUNS.
- CONCRETE CABLE MARKERS AND DUCT MARKERS SHALL HAVE LETTERS 4" HIGH, 3" WIDE WITH WIDTH OF STROKE 1/2" AND 1/4" DEEP. ALL LETTERS, NUMBERS AND ARROWS TO BE IMPRESSED.

TYPICAL SECTION
NOT TO SCALE

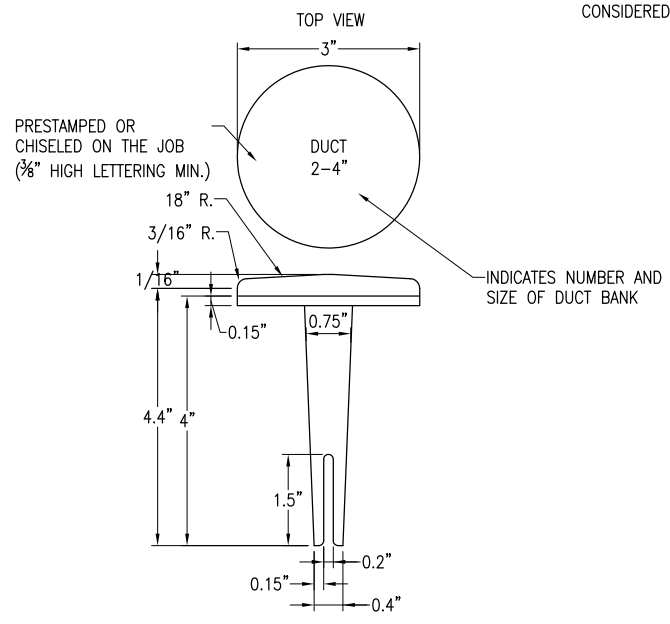
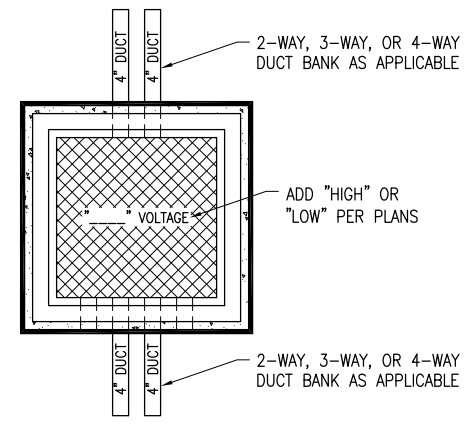

BITUMINOUS PAVEMENT DUCT MARKERS
NOT TO SCALE

- NOTES:**
- TOP OF MARKER SHALL BE FLUSH WITH FINISHED PAVEMENT SURFACE. MARKER MAY BE INSTALLED IN A DRILLED HOLE AND SECURED WITH EPOXY GLUE.
 - BRASS DUCT MARKERS ARE AVAILABLE FROM G&S FOUNDRY & MANUFACTURING CO., INC, 210 KASKASKIA DRIVE, RED BUD, IL 62278, PHONE: 618-282-4114.

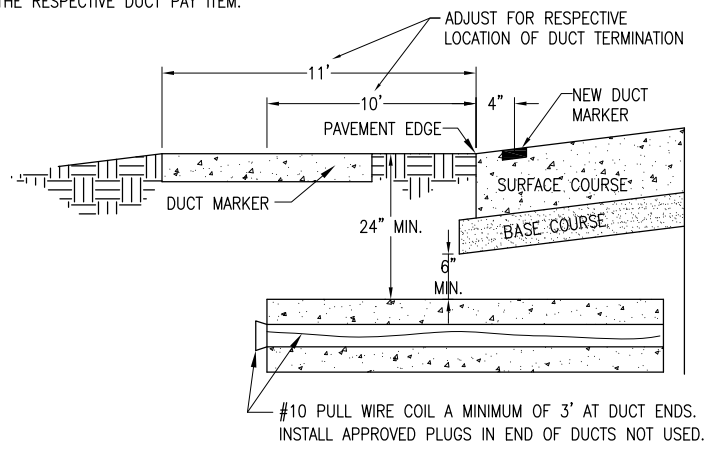

UNDERGROUND ELECTRICAL DUCT
NOT TO SCALE

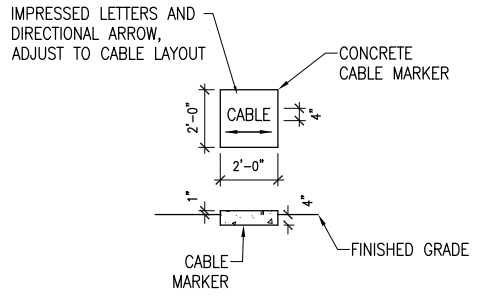

TURF CABLE MARKERS
NOT TO SCALE

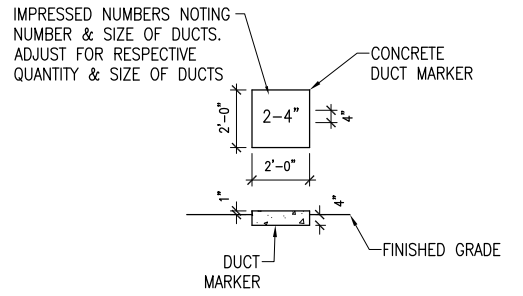

TURF DUCT MARKERS
NOT TO SCALE

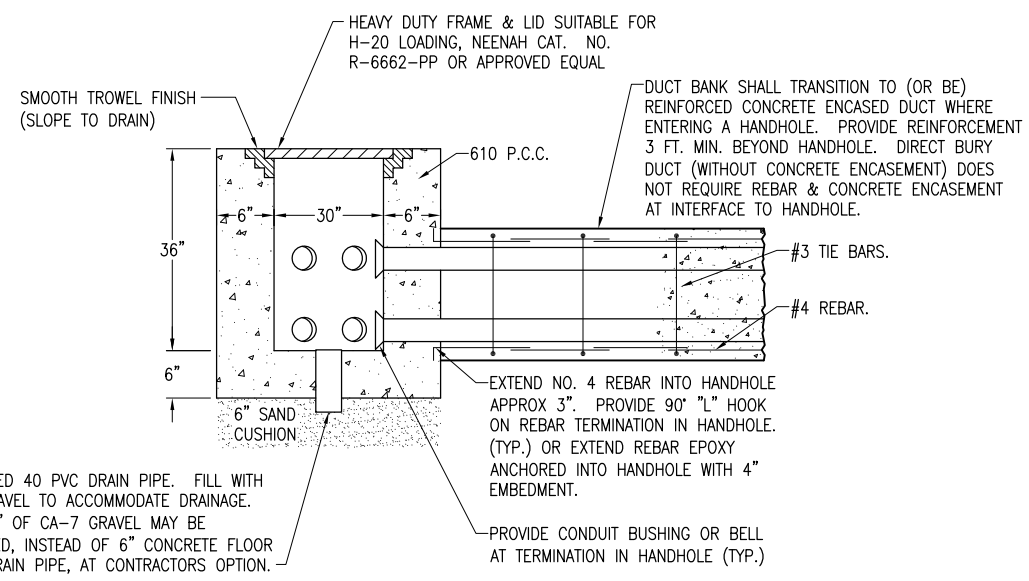

ELECTRICAL HANDHOLE
NOT TO SCALE

NOTES:

- LIDS FOR LOW VOLTAGE HANDHOLES SHALL BE LABELED "LOW VOLTAGE". LIDS FOR HIGH VOLTAGE HANDHOLES SHALL BE LABELED "HIGH VOLTAGE". COORDINATE LETTERING WITH MFR.
- HANDHOLES MAY BE CAST IN PLACE OR PRECAST. PRECAST MANUFACTURERS MUST BE ON IDOT (ILLINOIS DEPT. OF TRANSPORTATION) APPROVED LIST OF CERTIFIED PRECAST CONCRETE PRODUCERS.
- HANDHOLES WILL BE PAID FOR UNDER ITEM AR110610 ELECTRICAL HANDHOLE PER EACH. SEE SPECIAL PROVISIONS. FIBERGLASS HANDHOLES ARE NOT ACCEPTABLE.
- ALL CORING, INTERFACE, AND LABOR ASSOCIATED WITH CONDUIT, DUCT, CABLE IN UNIT DUCT, AND / OR CABLE ENTRIES WILL BE CONSIDERED INCIDENTAL TO THE INSTALLATION OF THE HANDHOLE AND NO ADDITIONAL COMPENSATION WILL BE ALLOWED.

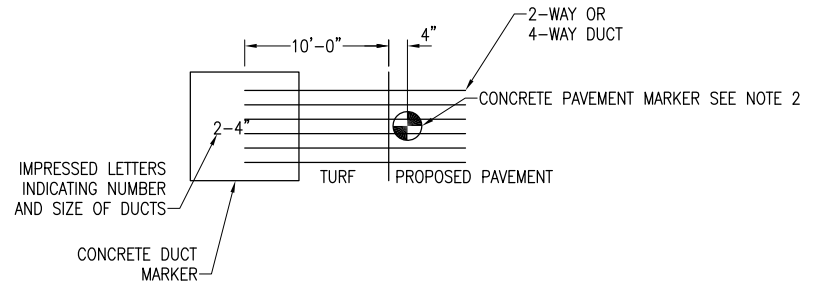

DUCT MARKER DETAIL
NOT TO SCALE

REVISION	DATE

ROCHELLE MUNICIPAL AIRPORT
MAJOR THOMAS F. KORITZ FIELD
ROCHELLE, ILLINOIS

IL PROJ.: RPJ-4136 A.I.P. PROJ.: 3-17-0087-B14

Hanson Project No. 10A0139D	JFC	08/21/11
Filename E-506-DTL.dwg	JFC	08/21/11
Scale AS SHOWN	CAH/KNL	08/21/11
Date 11/22/11	REVIEWED	08/21/11
LAYOUT	DRAWN	

HANSON
Professional Services Inc. 2011
Hanson Professional Services Inc.
1525 South Sixth Street
Springfield, Illinois 62703-2886
Ph: (217) 788-2450 Fax: (217) 788-2503
www.hanson-inc.com
Offices Nationwide

CONSTRUCT
ELECTRICAL VAULT

ELECTRICAL DETAILS
SHEET 2

REVISION	
DATE	

ROCHELLE MUNICIPAL AIRPORT
MAJOR THOMAS F. KORITZ FIELD
ROCHELLE, ILLINOIS

IL PROJ: RPJ-4136 ALP PROJ: 3-17-0087-B14

Hanson Project No.	10A0139D
Filename	E-002-NOT.dwg
Scale	AS SHOWN
Date	11/22/11
LAYOUT	JFC 10/21/11
DRAWN	JFC 10/21/11
REVIEWED	CAH/KNL 10/21/11

HANSON
Professional Services Inc. 2011
Hanson Professional Services Inc.
1525 South Sixth Street
Springfield, Illinois 62703-2886
Ph: (217) 788-2450 Fax: (217) 788-2503
www.hanson-inc.com
Offices Nationwide

CONSTRUCT
ELECTRICAL VAULT

ELECTRICAL NOTES
SHEET 1

GENERAL NOTES

- ALL ELECTRICAL EQUIPMENT SHALL BE INSTALLED IN CONFORMANCE WITH NFPA 70 - NATIONAL ELECTRICAL CODE (NEC) MOST CURRENT ISSUE IN FORCE, THE RESPECTIVE EQUIPMENT MANUFACTURER'S DIRECTIONS AND ALL OTHER APPLICABLE LOCAL CODES, LAWS, ORDINANCES, AND REQUIREMENTS IN FORCE. ANY INSTALLATIONS WHICH VOID THE U.L. LISTING, ETL LISTING (OR OTHER THIRD PARTY LISTING) AND/OR THE MANUFACTURER'S WARRANTY OF A DEVICE WILL NOT BE PERMITTED.
- CONTRACTOR SHALL KEEP A COPY OF THE LATEST NEC IN FORCE ON SITE AT ALL TIMES DURING CONSTRUCTION FOR USE AS A REFERENCE.
- CONTRACTOR SHALL COORDINATE WORK AND ANY POWER OUTAGES AND/OR SHUT DOWN OF SYSTEMS WITH THE RESPECTIVE FACILITY OWNER PERSONNEL AND THE AIRPORT MANAGER/DIRECTOR. ONCE SHUT DOWN, THE CIRCUITS SHALL BE LABELED AS SUCH TO PREVENT ACCIDENTAL ENERGIZING OF THE RESPECTIVE CIRCUITS. ALL PERSONNEL SHALL FOLLOW U.S. DEPARTMENT OF LABOR OCCUPATIONAL SAFETY & HEALTH ADMINISTRATION (OSHA) 29 CFR PART 1910 OCCUPATIONAL SAFETY & HEALTH STANDARDS FOR ELECTRICAL SAFETY AND LOCKOUT/TAGOUT PROCEDURES INCLUDING, BUT NOT LIMITED TO, 29 CFR SECTION 1910.147 THE CONTROL OF HAZARDOUS ENERGY (LOCKOUT/TAGOUT).
- THE CONTRACTOR SHALL ASCERTAIN THAT ALL LIGHTING SYSTEM COMPONENTS FURNISHED BY HIM, INCLUDING FAA APPROVED EQUIPMENT, ARE COMPATIBLE IN ALL RESPECTS WITH EACH OTHER AND THE REMAINDER OF THE NEW/EXISTING SYSTEM. ANY NONCOMPATIBLE COMPONENTS FURNISHED BY THIS CONTRACTOR SHALL BE REPLACED BY HIM AT NO ADDITIONAL COST TO THE AIRPORT SPONSOR WITH A SIMILAR UNIT, APPROVED BY THE ENGINEER (DIFFERENT MODEL OR DIFFERENT MANUFACTURER) THAT IS COMPATIBLE WITH THE REMAINDER OF THE AIRPORT LIGHTING SYSTEM.
- IN CASE THE CONTRACTOR ELECTS TO FURNISH AND INSTALL AIRPORT LIGHTING EQUIPMENT REQUIRING ADDITIONAL WIRING, TRANSFORMERS, ADAPTORS, MOUNTINGS, ETC., TO THOSE SHOWN ON THE DRAWINGS AND/OR LISTED IN THE SPECIFICATION, ANY COST FOR THESE ITEMS SHALL BE INCIDENTAL TO THE EQUIPMENT COST.
- THE CONTRACTOR INSTALLED EQUIPMENT (INCLUDING FAA APPROVED) SHALL NOT GENERATE ANY ELECTROMAGNETIC INTERFERENCE IN THE EXISTING AND/OR NEW COMMUNICATIONS, WEATHER, AIR NAVIGATION, AND AIR TRAFFIC CONTROL EQUIPMENT. ANY EQUIPMENT GENERATING SUCH INTERFERENCE SHALL BE REPLACED BY THE CONTRACTOR AT NO ADDITIONAL COST WITH THE EQUIPMENT MEETING THE APPLICABLE SPECIFICATIONS AND NOT GENERATING ANY INTERFERENCE.
- WHEN A SPECIFIC TYPE, STYLE, CLASS, ETC. OF FAA APPROVED EQUIPMENT IS SPECIFIED ONLY THAT TYPE, STYLE, CLASS, WILL BE ACCEPTABLE, EVEN THOUGH EQUIPMENT OF OTHER TYPES STYLES, CLASSES, ETC. MAY BE APPROVED.
- ANY AND ALL INSTRUCTIONS FROM THE RESIDENT ENGINEER TO THE CONTRACTOR REGARDING CHANGES IN OR DEVIATIONS FROM THE PLANS AND SPECIFICATIONS SHALL BE IN WRITING WITH COPIES SENT TO THE AIRPORT SPONSOR AND THE ILLINOIS DEPARTMENT OF TRANSPORTATION, DIVISION OF AERONAUTICS. THE CONTRACTOR SHALL NOT ACCEPT ANY VERBAL INSTRUCTIONS FROM THE RESIDENT ENGINEER REGARDING ANY CHANGES FROM THE PLANS AND SPECIFICATIONS.
- A MINIMUM OF THREE COPIES OF THE INSTRUCTION BOOK SHALL BE SUPPLIED WITH EACH DIFFERENT TYPE OF EQUIPMENT. THE BOOKS DESCRIBING A MORE SOPHISTICATED TYPE OF EQUIPMENT, SUCH AS REGULATORS, PAPI, REIL, ETC. AS A MINIMUM SHALL CONTAIN THE FOLLOWING:
 - A DETAILED DESCRIPTION OF THE OVERALL EQUIPMENT AND ITS INDIVIDUAL COMPONENTS.
 - THEORY OF OPERATION INCLUDING THE FUNCTION OF EACH COMPONENT.
 - INSTALLATION INSTRUCTION.
 - START-UP INSTRUCTIONS.
 - PREVENTATIVE MAINTENANCE REQUIREMENTS.
 - CHART FOR TROUBLE-SHOOTING.
 - COMPLETE POWER AND CONTROL DETAILED WIRING DIAGRAM(S), SHOWING EACH CONDUCTOR/CONNECTION/COMPONENT - "BLACK" BOXES ARE NOT ACCEPTABLE. THE DIAGRAM OF THE NARRATIVE SHALL SHOW VOLTAGE/CURRENTS/WAVE SHAPES AT STRATEGIC LOCATIONS TO BE USED WHEN CHECKING AND/OR TROUBLE-SHOOTING THE EQUIPMENT. WHEN THE EQUIPMENT HAS SEVERAL MODES OF OPERATION, SUCH AS SEVERAL BRIGHTNESS STEPS, THESE PARAMETERS SHALL BE INDICATED FOR ALL DIFFERENT MODES.
 - PARTS LIST WHICH WILL INCLUDE ALL MAJOR AND MINOR COMPONENTS SUCH AS RESISTORS, DIODES, ETC. IT SHALL INCLUDE A COMPLETE NOMENCLATURE OF EACH COMPONENT AND, IF APPLICABLE, THE NAME OF ITS MANUFACTURER AND THE CATALOG NUMBER.
 - SAFETY INSTRUCTIONS.

POWER AND CONTROL NOTES

- PROVIDE LEGEND PLATES FOR ALL ELECTRICAL EQUIPMENT TO IDENTIFY FUNCTION, CIRCUIT VOLTAGE AND PHASE. WHERE THE EQUIPMENT CONTAINS FUSES, ALSO IDENTIFY THE FUSE OR FUSE LINK AMPERE RATING. WHERE THE EQUIPMENT DOES NOT HAVE SUFFICIENT AREA TO INSTALL LEGEND PLATES, THE LEGEND PLATES SHALL BE INSTALLED ON THE WALL NEXT TO THE UNIT. LEGEND PLATES SHALL BE WEATHERPROOF ENGRAVED PLASTIC OR PHENOLIC MATERIAL, 1/4" HIGH BLACK LETTERS ON A WHITE BACKGROUND UNLESS NOTED OTHERWISE. SECURE WITH WEATHERPROOF ADHESIVE AND MACHINE SCREWS. FURNISH ADDITIONAL LEGEND PLATES WHERE REQUIRED BY CODE, FOR ADDITIONAL EQUIPMENT, AS DETAILED HEREIN ON THE PLANS, AND AS NOTED IN THE SPECIAL PROVISION SPECIFICATIONS.
- COLOR CODE ALL PHASE WIRING BY THE USE OF COLORED WIRE INSULATION AND/OR COLORED TAPE. WHERE TAPE IS USED, THE WIRE INSULATION SHALL BE BLACK. BLACK AND RED SHALL BE USED FOR PHASE CONDUCTORS ON 120/240VAC SINGLE-PHASE, THREE WIRE SYSTEMS AND BLACK, ORANGE (FOR HIGH LEG) AND BLUE SHALL BE USED FOR PHASE CONDUCTORS ON 240/120VAC THREE-PHASE, FOUR WIRE SYSTEMS. NEUTRAL CONDUCTORS, SIZE NO. 6 AWG OR SMALLER, SHALL BE IDENTIFIED BY A CONTINUOUS WHITE OR NATURAL GRAY OUTER FINISH ALONG ITS ENTIRE LENGTH. NEUTRAL CONDUCTORS LARGER THAN NO. 6 AWG SHALL BE IDENTIFIED EITHER BY A CONTINUOUS WHITE OR NATURAL GRAY OUTER FINISH ALONG ITS ENTIRE LENGTH OR BY THE USE OF WHITE TAPE AT ITS TERMINATIONS AND INSIDE ACCESSIBLE WIREWAYS. INSULATED GROUND CONDUCTORS SHALL HAVE GREEN COLORED INSULATION FOR ALL CONDUCTOR SIZES (AWG OR KCMIL).
- ALL BRANCH CIRCUIT CONDUCTORS CONNECTED TO A PARTICULAR PHASE SHALL BE IDENTIFIED WITH THE SAME COLOR. THE COLOR CODING SHALL BE EXTENDED TO THE POINT OF UTILIZATION.
- IN CONTROL WIRING THE SAME COLOR SHALL BE USED THROUGHOUT THE SYSTEM FOR THE SAME FUNCTION, SUCH AS 10%, 30%, 100% BRIGHTNESS CONTROL, ETC.
- LOW VOLTAGE (600 V.) AND HIGH VOLTAGE (5000 V.) CONDUCTORS SHALL BE INSTALLED IN SEPARATE WIREWAYS.
- NEATLY LACE WIRING IN DISTRIBUTION PANELS, WIREWAYS, SWITCHES AND JUNCTION/PULL BOXES.
- THE MINIMUM SIZE OF PULL/JUNCTION BOXES, REGARDLESS OF THE QUANTITY AND SIZE OF THE CONDUCTORS SHOWN, SHALL BE AS FOLLOWS:
 - IN STRAIGHT PULLS THE LENGTH OF THE BOX SHALL NOT BE LESS THAN EIGHT TIMES THE TRADE DIAMETER OF THE LARGER CONDUIT. THE TOTAL AREA (INCLUDING THE CONDUIT CROSS-SECTIONAL AREA) OF A BOX END SHALL BE AT LEAST 3 TIMES GREATER THAN THE TOTAL TRADE CROSS-SECTIONAL AREA OF THE CONDUITS TERMINATING AT THE END.
 - IN ANGLE PULLS OR 'U' PULLS THE DISTANCE BETWEEN EACH CONDUIT ENTRY INSIDE THE BOX AND THE OPPOSITE WALL OF THE BOX SHALL NOT BE LESS THAN SIX (6) TIMES THE TRADE DIAMETER OF THE LARGEST CONDUIT. THIS DISTANCE SHALL BE INCREASED FOR ADDITIONAL ENTRIES BY THE AMOUNT OF THE SUM OF THE DIAMETERS OF ALL OTHER CONDUIT ENTRIES ON THE SAME WALL AS THE BOX. THE DISTANCE BETWEEN CONDUIT ENTRIES ENCLOSING THE SAME CONDUCTOR SHALL NOT BE LESS THAN SIX TIMES THE TRADE DIAMETER OF THE LARGEST CONDUIT.
- A RUN OF CONDUIT BETWEEN TERMINATIONS AT EQUIPMENT ENCLOSURES, SQUARE DUCTS AND PULL/JUNCTION BOXES, SHALL NOT CONTAIN MORE THAN THE EQUIVALENT OF FOUR QUARTER BENDS (360 DEGREES TOTAL), INCLUDING THOSE BENDS LOCATED IMMEDIATELY AT THE TERMINATIONS, CAST, CONDUIT TYPE OUTLETS SHALL NOT BE TREATED AS PULL/JUNCTION BOXES.
- EQUIPMENT CABINETS SHALL NOT BE USED AS PULL/JUNCTION BOXES. ONLY WIRING TERMINATING AT THE EQUIPMENT SHALL BE BROUGHT INTO THESE ENCLOSURES.
- SPLICES AND JUNCTION POINTS SHALL BE PERMITTED ONLY IN JUNCTION BOXES, DUCTS EQUIPPED WITH REMOVABLE COVERS, AND AT EASILY ACCESSIBLE LOCATIONS.
- CIRCUIT BREAKERS IN POWER DISTRIBUTION PANEL(S) SHALL BE THERMAL-MAGNETIC MOLDED CASE, PERMANENT TRIP WITH 100 AMPERE, MINIMUM FRAME.
- DUAL LUGS SHALL BE USED WHERE TWO (2) WIRES, SIZE NO. 6 OR LARGER, ARE TO BE CONNECTED TO THE SAME TERMINAL.
- ALL INTERIOR WALL MOUNTED EQUIPMENT ENCLOSURES SHALL BE MOUNTED ON HOT DIPPED GALVANIZED STEEL STRUT SUPPORT, OR STAINLESS STEEL STRUT SUPPORT, WITH CORROSION RESISTANT HARDWARE.
- SUPPORT FOR EXTERIOR MOUNTED EQUIPMENT SHALL USE HOT DIPPED GALVANIZED STEEL STRUT SUPPORT OR STAINLESS STEEL STRUT SUPPORT WITH STAINLESS STEEL HARDWARE. PROVIDE ZINC RICH PAINT APPLIED TO FIELD CUTS OF GALVANIZED STEEL SUPPORT TO MINIMIZE THE POTENTIAL FOR CORROSION PER THE RESPECTIVE STRUT SUPPORT MANUFACTURER'S RECOMMENDATIONS.

- CONDUITS FOR ELECTRIC SERVICE ENTRANCE AND FEEDERS SHALL BE AS DETAILED HEREIN ON THE PLANS. WHERE GALVANIZED RIGID STEEL CONDUIT IS SPECIFIED IT SHALL HAVE THREADED FITTINGS. SET SCREW TYPE FITTINGS WILL NOT BE ACCEPTABLE. CONDUITS FOR UNDERGROUND APPLICATIONS SHALL BE AS DETAILED HEREIN. CONDUITS FOR GROUNDING ELECTRODE CONDUCTORS OR INDIVIDUAL GROUNDING CONDUCTORS SHALL BE SCHEDULE 40 OR SCHEDULE 80 PVC.
- PROVIDE LIQUID TIGHT FLEXIBLE METAL CONDUIT AT CONNECTIONS TO EQUIPMENT SUBJECT TO VIBRATION OR WHERE FLEXIBILITY IS REQUIRED. LIQUID TIGHT FLEXIBLE METAL CONDUIT AND ASSOCIATED FITTINGS SHALL BE U.L. LISTED TO MEET THE REQUIREMENTS OF NEC 350.6, SUITABLE FOR GROUNDING, SUNLIGHT RESISTANT, AND RESISTANT TO OIL, GASOLINE, AND GREASE. LIQUID TIGHT FLEXIBLE METAL CONDUIT THAT IS USED FOR FLEXIBILITY (INCLUDING CONNECTIONS TO MOTORS, TRANSFORMERS, & CONSTANT CURRENT REGULATORS) SHALL REQUIRE AN EXTERNAL BONDING JUMPER OR INTERNAL EQUIPMENT GROUNDING CONDUCTOR PER NEC 350.60. DO NOT INSTALL LIQUID TIGHT FLEXIBLE METAL CONDUIT THAT IS NOT UL LISTED. CONFIRM LIQUID-TIGHT FLEXIBLE METAL CONDUIT BEARS THE UL LABEL PRIOR TO INSTALLING IT.
- UNLESS OTHERWISE SHOWN, ALL EXPOSED CONDUITS SHALL BE RUN PARALLEL TO OR AT RIGHT ANGLES WITH THE LINES OF THE STRUCTURE.
- ALL STEEL CONDUITS, FITTINGS, NUTS, BOLTS, ETC. SHALL BE GALVANIZED.
- USE CONDUIT BUSHINGS AT EACH CONDUIT TERMINATION. WHERE NO. 4 AWG OR LARGER UNDERGROUND WIRE IS INSTALLED, USE INSULATED BUSHINGS.
- USE DOUBLE LOCK NUTS AT EACH CONDUIT TERMINATION.
- WRAP ALL PRIMARY AND SECONDARY POWER TRANSFORMER CONNECTIONS WITH SUFFICIENT LAYERS OF INSULATING TAPE (3M SCOTCH 23 ALL-VOLTAGE SPLICING TAPE, 3M SCOTCH 130C LINERLESS RUBBER SPLICING TAPE, OR APPROVED EQUAL) AND COVER WITH VINYL ELECTRICAL TAPE (3M SCOTCH 88 VINYL ELECTRICAL TAPE OR APPROVED EQUAL) FOR FULL VALUE OF CABLE INSULATION VOLTAGE.
- UNLESS OTHERWISE NOTED, ALL SINGLE CONDUCTOR CONTROL WIRING SHALL BE NO. 12 AWG. COPPER MINIMUM.
- THE FOLLOWING SHALL APPLY TO RELAY/CONTACTOR PANELS/ENCLOSURES:
 - FOR INTERIOR LOCATIONS ALL COMPONENTS SHALL BE MOUNTED IN NEMA 12 (DUST TIGHT) ENCLOSURE(S) WITH VERTICALLY HINGED COVERS. FOR EXTERIOR/OUTDOOR LOCATIONS ALL COMPONENTS SHALL BE MOUNTED IN NEMA 4X STAINLESS STEEL ENCLOSURE(S) WITH VERTICALLY HINGED COVERS. ALL CONDUIT ENTRIES INTO NEMA 4, 4X ENCLOSURES SHALL HAVE NEMA 4 HUBS LISTED SUITABLE FOR THE RESPECTIVE ENCLOSURE TO MAINTAIN THE NEMA 4, 4X RATING OF THE ENCLOSURE.
 - THE ENCLOSURE(S) SHALL HAVE AMPLE SPACE FOR THE CIRCUIT COMPONENTS, TERMINAL BLOCKS AND INCOMING AND INTERNAL WIRING.
 - ALL CONTROL CONDUCTOR TERMINATIONS SHALL BE OF THE OPEN-EYE CONNECTOR/SCREW TYPE. SOLDERED CLOSED-EYE TERMINATIONS, OR TERMINATIONS WITHOUT CONNECTORS ARE NOT ACCEPTABLE.
 - WHEN THE ENCLOSURE COVER IS OPENED, ALL CIRCUIT COMPONENTS, WIRING AND TERMINALS SHALL BE EXPOSED AND ACCESSIBLE WITHOUT REMOVAL OF ANY PANELS, COVERS, ETC., EXCEPT THOSE COVERING HIGH VOLTAGE COMPONENTS.
 - ACCESS TO, OR REMOVAL OF A CIRCUIT COMPONENT OR TERMINAL BLOCK WILL NOT REQUIRE THE REMOVAL OF ANY OTHER CIRCUIT COMPONENT OR TERMINAL BLOCK.
 - EACH CIRCUIT COMPONENT SHALL BE CLEARLY IDENTIFIED INDICATING ITS CORRESPONDING NUMBER SHOWN ON THE DRAWINGS AND ITS FUNCTION.
 - A COMPLETE WIRING DIAGRAM SHALL BE MOUNTED ON THE INSIDE OF THE COVER. THE DIAGRAM SHALL REPRESENT EACH CONDUCTOR BY A SEPARATE LINE.
 - THE DIAGRAM SHALL IDENTIFY EACH CIRCUIT COMPONENT AN NUMBERING AND COLOR OF EACH TERMINAL CONDUCTOR AND TERMINAL.
 - ALL WIRING SHALL BE NEATLY TRAINED AND LACED.
 - MINIMUM WIRE SIZE SHALL BE NO. 12 AWG.
- FURNISH & INSTALL A WEATHERPROOF WARNING LABEL FOR EACH METER SOCKET, SERVICE DISCONNECT, SAFETY SWITCH, CUTOUT, PANELBOARD, & CONTROL PANEL TO WARN PERSONS OF POTENTIAL ELECTRIC ARC FLASH HAZARDS, PER THE REQUIREMENTS OF NEC 110.16 "FLASH PROTECTION".

NOV 23, 2011 12:11 PM WALLE00723
pw:\sgr-svr306\hanson.dom\hanson_projects\Documents\10A0139D\10A0139D\CAD\Airport_Sheet[E-002-NOT

AIRFIELD LIGHTING NOTES

- UNLESS OTHERWISE NOTED, ALL UNDERGROUND AIRFIELD LIGHTING SERIES CIRCUIT CONDUCTORS WHETHER DEB OR IN DUCT/CONDUIT SHALL BE FAA APPROVED 5000 VOLT L-824 TYPE. ALL UNDERGROUND FIELD POWER LOW VOLTAGE (600 VOLT & BELOW) CIRCUIT CONDUCTORS WHETHER DEB OR IN DUCT/CONDUIT SHALL BE UL LISTED 600 VOLT, TYPE XLP-USE-2 COPPER CONDUCTORS. CONDUCTOR SIZES SHALL BE AS SPECIFIED, HEREIN.
- NO COMPONENTS OF PRIMARY CIRCUIT SUCH AS CABLE, CONNECTORS AND TRANSFORMERS SHALL BE BROUGHT ABOVE GROUND AT EDGE LIGHTS, SIGNS, REIL, PAPI, ETC.
- THERE SHALL BE NO EXPOSED POWER/CONTROL CABLES BETWEEN THE POINT WHERE THEY LEAVE THE UNDERGROUND (DEB OR L-867 BASES) AND WHERE THEY ENTER THE EQUIPMENT (SUCH AS TAXIWAY SIGNS, PAPI, REIL, ETC.) ENCLOSURES. THESE CABLES SHALL BE ENCLOSED IN RIGID CONDUIT OR IN FLEXIBLE, WATERTIGHT CONDUIT WITH BREAKABLE COUPLING(S) AT THE GRADE OR THE HOUSING COVER, AS SHOWN IN APPLICABLE DETAILS.
- THE JOINTS OF THE L-823 PRIMARY CONNECTORS SHALL BE WRAPPED WITH AT LEAST ONE LAYER OF RUBBER OR SYNTHETIC RUBBER TAPE AND ONE LAYER OF PLASTIC TAPE, ONE-HALF LAPPED, EXTENDING AT LEAST 1-1/2 INCHES ON EACH SIDE OF THE JOINT, AS SHOWN ON SHEET NO. 18.
- THE CABLE ENTRANCE INTO THE FIELD-ATTACHED L-823 CONNECTORS SHALL BE ENCLOSED BY A HEAT-SHRINKABLE TUBING WITH CONTINUOUS INTERNAL ADHESIVE, AS SHOWN ON SHEET NO. 18.
- L-823 TYPE II, TWO-CONDUCTOR SECONDARY CONNECTORS SHALL BE CLASS 'A' (FACTORY MOLDED).
- THERE SHALL BE NO SPLICES IN THE SECONDARY CABLE(S) WITHIN THE STEMS OF A RUNWAY/TAXIWAY EDGE/THRESHOLD LIGHTING FIXTURE AND THE WIREWAYS LEADING TO TAXIWAY SIGNS AND PAPI/REIL EQUIPMENT.
- ELECTRICAL INSULATING GREASE SHALL BE APPLIED WITHIN THE L-823, SECONDARY, TWO CONDUCTOR CONNECTORS TO PREVENT WATER ENTRANCE. THESE CONNECTORS SHALL NOT BE TAPED.
- DEB ISOLATION TRANSFORMERS SHALL BE BURIED AT A DEPTH OF TEN (10") INCHES ON A LINE CROSSING THE LIGHT AND PERPENDICULAR TO THE RUNWAY/TAXIWAY CENTERLINE AT A LOCATION TWELVE (12") INCHES FROM THE LIGHT OPPOSITE FROM THE RUNWAY/TAXIWAY.
- A SLACK OF THREE (3') FEET, MINIMUM, SHALL BE PROVIDED IN THE PRIMARY CABLE AT EACH TRANSFORMER/CONNECTOR TERMINATION. AT STAKE-MOUNTED LIGHTS, THE SLACK SHALL BE LOOSELY COILED IMMEDIATELY BELOW THE ISOLATION TRANSFORMER.
- DIRECTION OF PRIMARY CABLES SHALL BE IDENTIFIED BY COLOR CODING AS FOLLOWS: WHEN FACING LIGHT WITH BACK TO PAVEMENT, CABLE TO THE LEFT IS CODED RED AND CABLE TO RIGHT IS CODED BLUE. THIS APPLIES TO STAKE MOUNTED LIGHTS AND BASE MOUNTED LIGHTS WHERE THE BASE HAS ONLY ONE ENTRANCE.
- L-867 BASES SHALL BE SIZE B, 24" DEEP, CLASS I, UNLESS OTHERWISE NOTED.
- BASE MOUNTED BREAKABLE COUPLINGS SHALL NOT HAVE WEEP HOLES TO THE OUTSIDE. PLUGGED UP HOLES SHALL NOT BE ACCEPTABLE. IT SHALL BE A 1/4" DIAMETER, MINIMUM, OR EQUIVALENT OPENING FOR DRAINAGE FROM THE SPACE AROUND THE SECONDARY CONNECTOR INTO THE L-867 BASE.
- THE ELEVATION OF THE BREAKABLE COUPLING GROOVE SHALL NOT EXCEED 1-1/2" ABOVE THE EDGE OF THE COVER IN CASE OF BASE MOUNTED COUPLINGS, OR THE TOP OF THE STAKE IN CASE OF STAKE MOUNTED COUPLINGS.
- WHERE THE BREAKABLE COUPLING IS NOT AN INTEGRAL PART OF THE LIGHT FIXTURE STEM OR MOUNTING LEG, A BEAD OF SILICON SEAL SHALL BE APPLIED COMPLETELY AROUND LIGHT STEM OR WIREWAY AT BREAKABLE COUPLING TO PROVIDE A WATERTIGHT SEAL.
- TOPS OF THE STAKES SUPPORTING LIGHT FIXTURES SHALL BE FLUSH WITH THE SURROUNDING GRADE.
- PLASTIC LIGHTING FIXTURE COMPONENTS, SUCH AS LAMP HEADS, STEMS, BREAKABLE COUPLINGS, BASE COVERS, BRACKETS, STAKES, SHALL NOT BE ACCEPTABLE.
- THE TOLERANCE FOR THE HEIGHT OF RUNWAY/TAXIWAY EDGE LIGHTS SHALL BE: ONE (1) INCH. IN CASE OF STAKE MOUNTED LIGHTS, THE SPECIFIED LIGHTING FIXTURE HEIGHT SHALL BE MEASURED BETWEEN THE TOP OF THE STAKE AND THE TOP OF THE LENS. IN CASE OF BASE MOUNTED LIGHTS, THE SPECIFIED LIGHTING FIXTURE HEIGHT SHALL BE MEASURED BETWEEN THE TOP OF THE BASE FLANGE AND THE TOP OF THE LENS, THUS INCLUDING THE BASE COVER, THE FRANGIBLE COUPLING, THE STEM, THE LAMP HOUSING AND THE LENS.
- THE TOLERANCE FOR THE LATERAL SPACING (LIGHT LANE TO RUNWAY/TAXIWAY CENTERLINE) OF RUNWAY/TAXIWAY EDGE LIGHTS SHALL BE ONE (1) INCH. THIS ALSO APPLIES AT INTERSECTIONS TO LATERAL SPACING BETWEEN LIGHTS OF A RUNWAY/TAXIWAY AND THE INTERSECTING RUNWAY/TAXIWAY.

- ENTRANCES INTO L-867 BASES SHALL HAVE CONDUIT COUPLINGS OR REDUCERS TO INTERFACE UNIT DUCT/CONDUIT TO L-867 BASE HUBS, OR SHALL BE SEALED WITH HEAT SHRINK.
- GALVANIZED/PAINTED EQUIPMENT/COMPONENT SURFACES SHALL NOT BE DAMAGED BY DRILLING, FILING, ETC. DRAIN HOLES IN METAL TRANSFORMER HOUSINGS SHALL BE MADE BEFORE GALVANIZING.
- EDGE LIGHT NUMBERING TAGS SHALL BE FACING THE PAVEMENT.
- CABLE/SPLICE/DUCT MARKERS SHALL BE PRECAST CONCRETE OF THE SIZE SHOWN. LETTERS/NUMBERS/ARROWS FOR THE LEGEND TO BE IMPRESSED INTO THE TOPS OF THE MARKERS SHALL BE PRE-ASSEMBLED AND SECURED IN THE MOLD BEFORE THE CONCRETE IS POURED. LEGEND INSCRIBED BY HAND IN WET CONCRETE SHALL NOT BE ACCEPTABLE.
- ALL UNDERGROUND CABLE RUNS SHALL BE IDENTIFIED BY CABLE MARKERS AT 200 FEET MAXIMUM SPACING, WITH AN ADDITIONAL MARKER AT EACH CHANGE OF DIRECTION OF THE CABLE RUN. CABLE MARKERS SHALL BE INSTALLED IMMEDIATELY ABOVE THE CABLES.
- THERE SHALL BE NO SPLICES BETWEEN THE ISOLATION TRANSFORMERS. L-823 CONNECTORS ARE ALLOWED AT TRANSFORMER CONNECTIONS ONLY, UNLESS OTHERWISE SHOWN.
- APPLY AN OXIDE INHIBITING, ANTI-SEIZING COMPOUND TO ALL SCREWS, NUTS AND BREAKAGE COUPLING THREADS.
- LOCATIONS OF ENDS OF ALL UNDERGROUND DUCTS SHALL BE IDENTIFIED BY DUCT MARKERS.
- WHERE A PARALLEL, CONSTANT VOLTAGE PAPI SYSTEM IS PROVIDED, THE "T" SPLICES SHALL BE OF THE CAST TYPE.
- CONCRETE USED FOR SLABS, FOOTINGS, BACKFILL AROUND TRANSFORMER HOUSINGS, MARKINGS, ETC. SHALL BE 3500 PSI, AIR-ENTRAINED.
- ALL POWER AND CONTROL CABLES IN MAN/HAND HOLES SHALL BE TAGGED. USE EMBOSSED COPPER STRIPS TO BE ATTACHED AT BOTH ENDS TO THE CABLE BY THE USE OF PLASTIC STRAPS. MINIMUM OF TWO TAGS SHALL BE PROVIDED ON EACH CABLE IN A MAN/HAND HOLE-ONE AT THE CABLE ENTRANCE AND ONE AT THE CABLE EXIT.
- THE LOCATION, SIZE AND TYPE OF MATERIAL OF EXISTING UNDERGROUND AND/OR ABOVEGROUND UTILITIES INDICATED ON THE PLANS IS NOT REPRESENTED AS BEING ACCURATE, SUFFICIENT OR COMPLETE. NEITHER THE OWNER NOR THE ENGINEER ASSUMES ANY RESPONSIBILITY WHATEVER IN RESPECT TO ACCURACY, COMPLETENESS, OR SUFFICIENCY OF THE INFORMATION. THERE IS NO GUARANTEE EITHER EXPRESSED OR IMPLIED, THAT THE LOCATIONS, SIZE AND TYPE OF MATERIAL OF EXISTING UNDERGROUND UTILITIES INDICATED ARE REPRESENTATIVE OF THOSE TO BE ENCOUNTERED IN THE CONSTRUCTION. IT SHALL BE THE CONTRACTOR'S RESPONSIBILITY TO DETERMINE THE ACTUAL LOCATION OF ALL SUCH FACILITIES, INCLUDING SERVICE CONNECTIONS TO UNDERGROUND UTILITIES. PRIOR TO CONSTRUCTION, THE CONTRACTOR SHALL NOTIFY THE UTILITY COMPANIES OF HIS OPERATIONAL PLANS AND SHALL OBTAIN FROM THE RESPECTIVE UTILITY COMPANIES DETAILED INFORMATION AND ASSISTANCE RELATIVE TO THE LOCATION OF THEIR FACILITIES AND THE WORKING SCHEDULE OF THE COMPANIES FOR REMOVAL OR ADJUSTMENT WHERE REQUIRED. IN THE EVENT AN UNEXPECTED UTILITY INTERFERENCE IS ENCOUNTERED DURING CONSTRUCTION, THE CONTRACTOR SHALL IMMEDIATELY NOTIFY THE UTILITY COMPANY OF JURISDICTION. THE OWNER'S REPRESENTATIVE AND/OR THE RESIDENT ENGINEER SHALL ALSO BE IMMEDIATELY NOTIFIED. ANY DAMAGE TO SUCH MAINS AND SERVICES SHALL BE RESTORED TO SERVICE AT ONCE AND PAID FOR BY THE CONTRACTOR AT NO ADDITIONAL COST TO THE CONTRACT. ALL UTILITY CABLES AND LINES SHALL BE LOCATED BY THE RESPECTIVE UTILITY. CONTACT JULIE (JOINT UTILITY LOCATION INFORMATION FOR EXCAVATORS) FOR UTILITY INFORMATION, PHONE: 1-800-892-0123. CONTACT THE FAA (FEDERAL AVIATION ADMINISTRATION) FOR ASSISTANCE IN LOCATING FAA CABLES AND UTILITIES. LOCATION OF FAA POWER, CONTROL AND COMMUNICATION CABLES SHALL BE COORDINATED WITH AND/OR LOCATED BY THE FAA. ALSO CONTACT AIRPORT DIRECTOR/MANAGER AND AIRPORT PERSONNEL FOR ASSISTANCE IN LOCATING UNDERGROUND AIRPORT CABLES AND/OR UTILITIES. ALSO COORDINATE WORK WITH ALL ABOVE GROUND UTILITIES.
- WHEN PREPARING CABLE FOR SPLICES, THE CONTRACTOR SHALL USE A CABLE STRIPPER/PENCILLER WHENEVER CABLE CONNECTIONS ARE MADE.

GROUNDING NOTES FOR AIRFIELD LIGHTING

- GROUNDING FOR RUNWAY LIGHTS, TAXIWAY LIGHTS, AND LIGHTED TAXI GUIDANCE SIGNS SHALL BE AS DETAILED ON THE PLANS AND AS SPECIFIED HEREIN. PER FAA AC 150/5340-30E DESIGN AND INSTALLATION DETAILS FOR AIRPORT VISUAL AIDS, CHAPTER 12, PART 12.6; A GROUND MUST BE INSTALLED AT EACH LIGHT FIXTURE. THE PURPOSE OF THE LIGHT BASE GROUND IS TO PROVIDE A DEGREE OF PROTECTION FOR MAINTENANCE PERSONNEL FROM POSSIBLE CONTACT WITH AN ENERGIZED LIGHT BASE OR MOUNTING STAKE THAT MAY RESULT FROM A SHORTED POWER CABLE OR ISOLATION TRANSFORMER. A LIGHT BASE GROUND SHALL BE INSTALLED AT EACH TRANSFORMER BASE/LIGHT CAN ASSOCIATED WITH RUNWAY LIGHTS, TAXIWAY LIGHTS, AND LIGHTED TAXI GUIDANCE SIGNS. A LIGHT BASE GROUND SHALL ALSO BE INSTALLED AT EACH STAKE MOUNTED LIGHT FIXTURE. A LIGHT BASE GROUND SHALL BE INSTALLED AND BONDED TO THE METAL FRAME OF EACH TAXI GUIDANCE SIGN AS DETAILED ON THE PLANS AND IN ACCORDANCE WITH THE RESPECTIVE TAXI GUIDANCE SIGN MANUFACTURER RECOMMENDATIONS. THE LIGHT BASE GROUND SHALL BE A #6 AWG BARE COPPER CONDUCTOR BONDED TO THE GROUND LUG ON THE RESPECTIVE L-867 TRANSFORMER BASE/LIGHT CAN OR MOUNTING STAKE AND A 5/8-INCH DIAMETER BY 8-FOOT LONG (MINIMUM) UL LISTED COPPER CLAD GROUND ROD. CONNECTIONS TO GROUND LUGS ON THE L-867 TRANSFORMER BASE/LIGHT CAN OR MOUNTING STAKE SHALL BE WITH A UL LISTED GROUNDING CONNECTOR. CONNECTIONS TO GROUND RODS SHALL BE MADE WITH EXOTHERMIC WELD TYPE CONNECTORS, CADWELD BY ERICO PRODUCTS, INC., SOLON, OHIO, (PHONE: 800-248-9353), THERMOWELD BY CONTINENTAL INDUSTRIES, INC., TULSA, OKLAHOMA (PHONE: 918-663-1440), ULTRAWELD BY HARGER, GRAYSLAKE, ILLINOIS (PHONE: 800-842-7437), OR APPROVED EQUAL. EXOTHERMIC WELD CONNECTIONS SHALL BE INSTALLED IN CONFORMANCE WITH THE RESPECTIVE MANUFACTURER'S DIRECTIONS USING MOLDS AS REQUIRED FOR EACH RESPECTIVE APPLICATION. BOLTED CONNECTIONS WILL NOT BE PERMITTED AT GROUND RODS. TOP OF GROUND RODS SHALL BE BURIED 12 INCHES MINIMUM BELOW GRADE, UNLESS SPECIFIED OTHERWISE HEREIN, FOR RESPECTIVE APPLICATIONS.
- CLEAN ALL METAL SURFACES BEFORE MAKING GROUND CONNECTIONS. METALLIC SURFACES TO BE JOINED SHALL BE PREPARED BY THE REMOVAL OF ALL NON-CONDUCTIVE MATERIAL PER 2008 NATIONAL ELECTRICAL CODE ARTICLE 250-12.
- PER FAA 150/5340-30E THE RESISTANCE TO GROUND OF THE RESPECTIVE MOUNTING STAKE OR LIGHT BASE (WITH GROUND ROD CONNECTED) MUST BE 25 OHMS OR LESS.

NOV 23, 2011 12:22 PM WALLE00723
pw:\sgr-svr306\hanson.dom\hanson\Projects\Documents\10\100139\100139\100139\CAD\Airport\Sheet\E-004-NOT

REVISION	DATE

ROCHELLE MUNICIPAL AIRPORT
MAJOR THOMAS F. KORITZ FIELD
ROCHELLE, ILLINOIS

IL PROJ.: RPJ-4136 A.I.P. PROJ.: 3-17-0087-B14

Hanson Project No. 100139D	File Name E-004-NOT.dwg	Scale AS SHOWN	Date 11/22/11	LAYOUT 10/11/21
				JFC 10/21/11
				REVIEWED CAH/KNL 10/11/21



© Copyright Hanson Professional Services Inc. 2011
Hanson Professional Services Inc.
 1525 South Sixth Street
 Springfield, Illinois 62703-2886
 Ph: (217) 788-2450 Fax: (217) 788-2503
 www.hanson-inc.com
 Offices Nationwide

CONSTRUCT
ELECTRICAL VAULT

ELECTRICAL NOTES
SHEET 2

ELECTRICAL LEGEND - ONE-LINE DIAGRAM	
	CABLE TERMINATOR/LUG
	TRANSFORMER
	DISCONNECT SWITCH
	FUSIBLE DISCONNECT SWITCH
	CIRCUIT BREAKER
	THERMAL MAGNETIC CIRCUIT BREAKER
	FUSE
	TRANSIENT VOLTAGE SURGE SUPPRESSOR OR SURGE PROTECTOR DEVICE
	GROUND - GROUND ROD, GROUNDING ELECTRODE, OR AT EARTH POTENTIAL
	INDICATING LIGHT
	MOTOR
	LOAD, MOTOR, # = HORSEPOWER
	ELECTRIC UTILITY METER BASE
	JUNCTION BOX WITH SPLICE
	EQUIPMENT, XXX = DEVICE DESCRIPTION
	GROUND BUS OR TERMINAL
	NEUTRAL BUS
	PANELBOARD WITH MAIN LUGS
	PANELBOARD WITH MAIN BREAKER
	FUSE PANEL WITH MAIN FUSE PULLOUT
	DUPLEX RECEPTACLE 120V SINGLE PHASE GROUNDING TYPE
	CONTROL STATION
	TRANSFER SWITCH
	ENGINE GENERATOR SET

ELECTRICAL LEGEND - SCHEMATIC	
	NORMALLY OPEN (N.O.) CONTACT
	NORMALLY CLOSED (N.C.) CONTACT
	STARTER COIL, * = STARTER NUMBER
	OVERLOAD RELAY CONTACT
	CONTROL RELAY, * = CONTROL RELAY NUMBER
	RELAY, * = RELAY NUMBER
	TOGGLE SWITCH / 2 POSITION SWITCH
	2-POSITION SELECTOR SWITCH
	3-POSITION SELECTOR SWITCH (H-O-A SHOWN)
	2 POLE DISCONNECT SWITCH
	3 POLE DISCONNECT SWITCH
	PHOTOCELL
	TERMINAL BLOCK, * = TERMINAL NUMBER
	DEVICE TERMINAL, * = DEVICE TERMINAL NUMBER
	INTERNAL PANEL WIRING
	FIELD WIRING
	FUSE
	GROUND BUS OR TERMINAL
	NEUTRAL BUS
	GROUND, GROUND ROD, GROUND BUS
	INDUSTRIAL CONTROL RELAY OR LIGHTING CONTACTOR
	S1 CUTOUT HANDLE REMOVED
	S1 CUTOUT HANDLE INSERTED
	N.O. THERMAL SWITCH
	N.C. THERMAL SWITCH
	L-830 SERIES ISOLATION TRANSFORMER

ELECTRICAL ABBREVIATIONS	
A.F.F.	ABOVE FINISHED FLOOR
A, AMP	AMPERES
ATS	AUTOMATIC TRANSFER SWITCH
AWG	AMERICAN WIRE GAUGE
BKR	BREAKER
C	CONDUIT
CB	CIRCUIT BREAKER
CKT	CIRCUIT
CR	CONTROL RELAY
CU	COPPER
DPDT	DOUBLE POLE DOUBLE THROW
DPST	DOUBLE POLE SINGLE THROW
EM	EMERGENCY
EMT	ELECTRICAL METALLIC TUBING
ENCL	ENCLOSURE
EP	EXPLOSION PROOF
ES	EMERGENCY STOP
ETL	INTERTEK - ELECTRICAL TESTING LABS
ETM	ELAPSE TIME METER
GFCI	GROUND FAULT CIRCUIT INTERRUPTER
GFI	GROUND FAULT INTERRUPTER
GND	GROUND
GRSC	GALVANIZED RIGID STEEL CONDUIT
HID	HIGH INTENSITY DISCHARGE
HOA	HAND OFF AUTOMATIC
HP	HORSEPOWER
HPS	HIGH PRESSURE SODIUM
J	JUNCTION BOX
KVA	KILOVOLT AMPERE(S)
KW	KILOWATTS
LC	LIGHTING CONTACTOR
LTFCM	LIQUID TIGHT FLEXIBLE METAL CONDUIT (UL LISTED)
LTG	LIGHTING
LP	LIGHTING PANEL
MAX	MAXIMUM
MCB	MAIN CIRCUIT BREAKER
MCM	THOUSAND CIRCUAR MIL
MDP	MAIN DISTRIBUTION PANEL
MFR	MANUFACTURER
MH	METAL HALIDE
MIN	MINIMUM
MLO	MAIN LUGS ONLY
NEC	NATIONAL ELECTRICAL CODE (NFPA 70)
NC	NORMALLY CLOSED
NO	NORMALLY OPEN
NTS	NOT TO SCALE
OHE	OVERHEAD ELECTRIC
OL	OVERLOAD

ELECTRICAL ABBREVIATIONS (CONTINUED)	
PB	PULL BOX
PC	PHOTO CELL
PDB	POWER DISTRIBUTION BLOCK
PNL	PANEL
RCPT	RECEPTACLE
R	RELAY
S	STARTER
SPD	SURGE PROTECTION DEVICE
SPST	SINGLE POLE SINGLE THROW
TVSS	TRANSIENT VOLTAGE SURGE SUPPRESSOR
TYP	TYPICAL
UG	UNDERGROUND
UGE	UNDERGROUND ELECTRIC
UL	UNDERWRITER'S LABORATORIES
V	VOLTS
W/	WITH
W/O	WITHOUT
WP	WEATHER PROOF
XFER	TRANSFER
XFMR	TRANSFORMER

AIRPORT EQUIPMENT/FACILITY ABBREVIATIONS	
ASOS	AUTOMATED SURFACE OBSERVING SYSTEM
ATCT	AIR TRAFFIC CONTROL TOWER
AWOS	AUTOMATED WEATHER OBSERVING SYSTEM
CCR	CONSTANT CURRENT REGULATOR
DME	DISTANCE MEASURING EQUIPMENT
FAR	FEDERAL AVIATION REGULATION
GS	GLIDE SLOPE FACILITY
HIRL	HIGH INTENSITY RUNWAY LIGHT
ILS	INSTRUMENT LANDING SYSTEM
IM	INNER MARKER
LIR	LOW IMPACT-RESISTANT
LOC	LOCALIZER FACILITY
MALS	MEDIUM INTENSITY APPROACH LIGHTING SYSTEM
MALSR	MEDIUM INTENSITY APPROACH LIGHTING SYSTEM WITH RUNWAY ALIGNMENT INDICATING LIGHTS
MIRL	MEDIUM INTENSITY RUNWAY LIGHT
MITL	MEDIUM INTENSITY TAXIWAY LIGHT
NDB	NON-DIRECTIONAL BEACON
PAPI	PRECISION APPROACH PATH INDICATOR
PLASI	PULSE LIGHT APPROACH SLOPE INDICATOR
RAIL	RUNWAY ALIGNMENT INDICATING LIGHTS
REIL	RUNWAY END IDENTIFIER LIGHT
RVR	RUNWAY VISUAL RANGE
VADI	VISUAL APPROACH DESCENT INDICATOR
VASI	VISUAL APPROACH SLOPE INDICATOR
VOR	VERY HIGH FREQUENCY OMNIDIRECTIONAL RANGE FACILITY
WC	WIND CONE

NOTES:

- ALL ELECTRICAL EQUIPMENT SHALL BE INSTALLED IN CONFORMANCE WITH NFPA 70 - NATIONAL ELECTRICAL CODE (NEC) MOST CURRENT ISSUE IN FORCE, THE RESPECTIVE EQUIPMENT MANUFACTURER'S DIRECTIONS AND ALL OTHER APPLICABLE LOCAL CODES, LAWS, ORDINANCES, AND REQUIREMENTS IN FORCE. ANY INSTALLATIONS WHICH VOID THE U.L. LISTING, ETL LISTING (OR OTHER THIRD PARTY LISTING) AND/OR THE MANUFACTURER'S WARRANTY OF A DEVICE WILL NOT BE PERMITTED.
- ALL VAULT WORK, POWER OUTAGES, AND/OR SHUT DOWN OF EXISTING SYSTEMS SHALL BE COORDINATED WITH THE AIRPORT MANAGER. ONCE SHUT DOWN, THE CIRCUITS SHALL BE LABELED AS SUCH TO PREVENT ACCIDENTAL ENERGIZING OF THE RESPECTIVE CIRCUITS. ALL PERSONNEL SHALL FOLLOW U.S. DEPARTMENT OF LABOR OCCUPATIONAL SAFETY & HEALTH ADMINISTRATION (OSHA) 29 CFR PART 1910 OCCUPATIONAL SAFETY & HEALTH STANDARDS FOR ELECTRICAL SAFETY AND LOCKOUT/TAGOUT PROCEDURES INCLUDING, BUT NOT LIMITED TO, 29 CFR SECTION 1910.147 THE CONTROL OF HAZARDOUS ENERGY (LOCKOUT/TAGOUT).
- COLOR CODE PHASE AND NEUTRAL CONDUCTOR INSULATION FOR NO. 6 AWG OR SMALLER. PROVIDE COLORED INSULATION OR COLORED MARKING TAPE FOR PHASE AND NEUTRAL CONDUCTORS FOR NO. 4 AWG AND LARGER. INSULATED GROUND CONDUCTORS SHALL HAVE GREEN COLORED INSULATION FOR ALL CONDUCTOR AWG AND/OR KCMIL TO COMPLY WITH NEC 250.119. NEUTRAL CONDUCTORS SHALL HAVE WHITE COLORED INSULATION FOR NO. 6 AWG AND SMALLER TO MEET THE REQUIREMENTS OF NEC 200.6. STANDARD COLORS FOR POWER WIRING AND BRANCH CIRCUITS SHALL BE AS FOLLOWS:

120/240 VAC, 1 PHASE, 3 WIRE

PHASE A	BLACK
PHASE B	RED
NEUTRAL	WHITE
GROUND	GREEN
- SEE RESPECTIVE SITE PLANS FOR SITE LEGEND INFORMATION.
- LTFCM DENOTES LIQUID TIGHT FLEXIBLE METAL CONDUIT UL LISTED, SUNLIGHT RESISTANT, & SUITABLE FOR GROUNDING. LIQUID TIGHT FLEXIBLE METAL CONDUIT AND ASSOCIATED FITTINGS SHALL BE U.L. LISTED TO MEET THE REQUIREMENTS OF NEC 350.6. LIQUID TIGHT FLEXIBLE METAL CONDUIT THAT IS USED FOR FLEXIBILITY (INCLUDING CONNECTIONS TO CCR'S & TRANSFORMERS) SHALL REQUIRE AN EXTERNAL BONDING JUMPER OR INTERNAL EQUIPMENT GROUNDING CONDUCTOR PER NEC 350.60. EXTERNAL BONDING JUMPERS USED WITH CCR INSTALLATIONS SHALL BE #6 AWG COPPER (MINIMUM). DO NOT INSTALL LTFCM THAT IS NOT UL LISTED. CONFIRM LTFCM BEARS THE UL LABEL PRIOR TO INSTALLATION.
- ALL ENCLOSURES RATED NEMA 4, 4X SHALL HAVE WATERTIGHT HUBS AT CONDUIT ENTRANCES U.L. LISTED NEMA 4, 4X FOR THE RESPECTIVE ENCLOSURE, TO MAINTAIN THE NEMA 4, 4X RATING.
- HIGH VOLTAGE & LOW VOLTAGE CIRCUITS SHALL NOT BE INSTALLED IN THE SAME WIREWAY, CONDUIT, DUCT, OR HANDHOLE.

NOV 23, 2011 12:22 PM WALLE00723
 p:\s\svr306.hanson.dom\Projects\Documents\1040139\1040139D\CAD\Airport\Sheet\E-001-NOT

REVISION					
DATE					
ROCHELLE MUNICIPAL AIRPORT MAJOR THOMAS F. KORITZ FIELD ROCHELLE, ILLINOIS					
I.L. PROJ.: RPJ-4136 A.I.P. PROJ.: 3-17-0087-B14					
Hanson Project No. 1040139D Filename E-001-NOT.dwg Scale AS SHOWN Date 11/22/11		LAYOUT JFC 10/21/11 DRAWN JFC 10/21/11 REVIEWED CHY/KNL 10/21/11		 © Copyright Hanson Professional Services Inc. 2011 Hanson Professional Services Inc. 1525 South Sixth Street Springfield, Illinois 62703-2886 Ph: (217) 788-2450 Fax: (217) 788-2503 www.hanson-inc.com Offices Nationwide	
CONSTRUCT ELECTRICAL VAULT		ELECTRICAL LEGEND AND ABBREVIATIONS			
9 9 of 24 sheets					

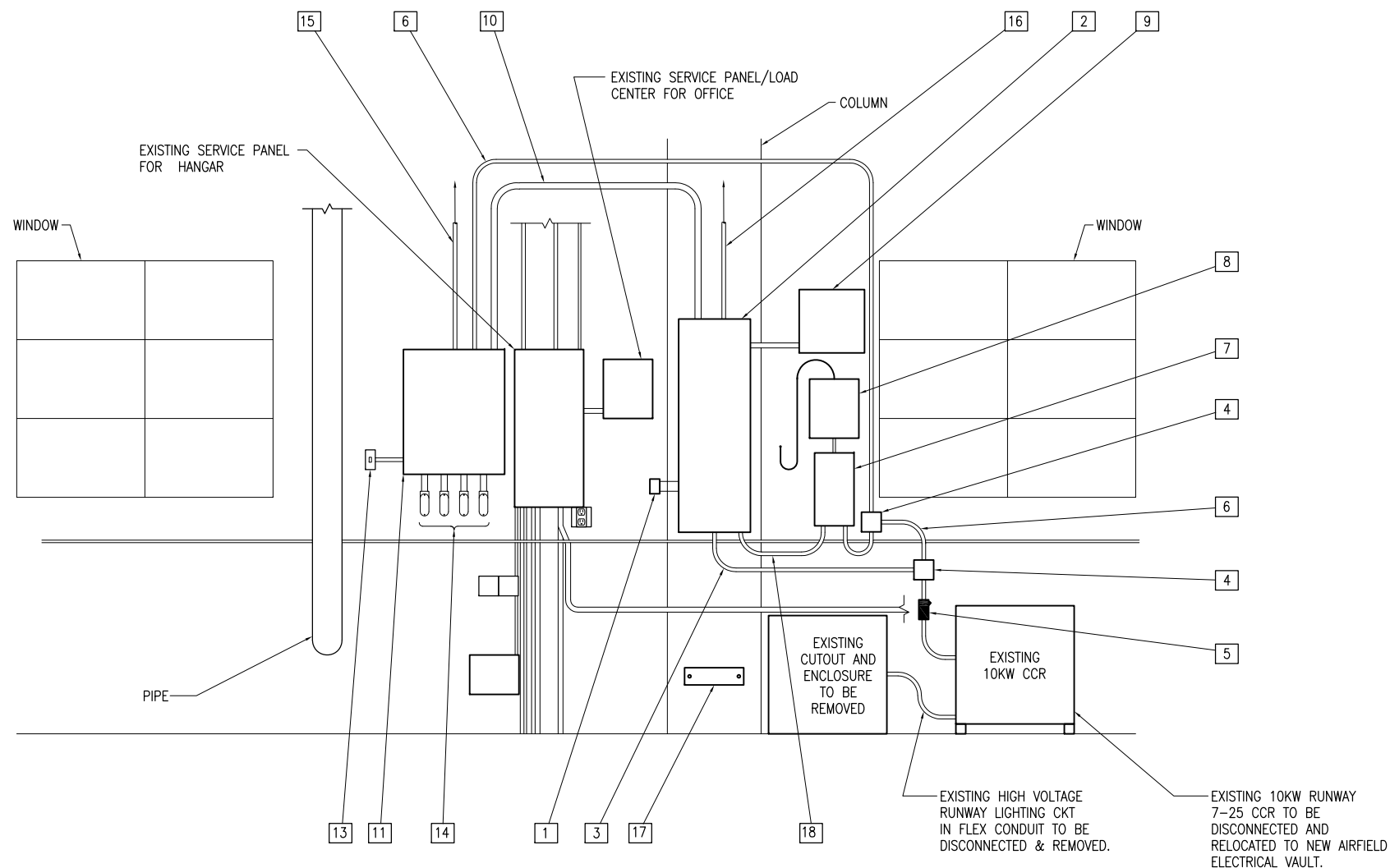

**AIRPORT VAULT EXISTING ELEVATION
(SOUTH WALL OF HANGAR)**

GENERAL NOTES

- PER NEC 513 THE ENTIRE AREA OF THE HANGAR INCLUDING ANY ADJACENT AND COMMUNICATING AREAS NOT SUITABLE CUT OFF FROM THE HANGAR, SHALL BE CLASSIFIED AS A CLASS 1, DIVISION 2 HAZARDOUS LOCATION UP TO A LEVEL 18 INCHES ABOVE THE FLOOR. AREAS IN THE VICINITY OF AIRCRAFT ARE ALSO CLASSIFIED AS HAZARDOUS AS DEFINED BY NEC 513. ALL ELECTRICAL INSTALLATIONS IN CLASSIFIED HAZARDOUS LOCATIONS SHALL BE AVOIDED UNLESS SPECIFICALLY APPROVED FOR SUCH LOCATIONS AND INSTALLED IN CONFORMANCE WITH NEC 500, 501, AND 513 AS WELL AS ANY OTHER APPLICABLE CODES AND REQUIREMENTS.
- ALL EQUIPMENT AND WIRING MADE OBSOLETE BY PROPOSED WORK SHALL BE REMOVED. ALL REMOVED EQUIPMENT SHALL BE TURNED OVER TO AIRPORT MANAGER.
- ALL EXISTING AIRFIELD CIRCUITS THAT ARE SCHEDULED TO BE REPLACED OR RE-FED FROM THE PROPOSED VAULT SHALL BE DISCONNECTED, REMOVED WHERE EXPOSED, ABOVE GRADE, OR WHERE NECESSARY TO ACCOMMODATE NEW WORK, & ABANDONED IN PLACE ELSEWHERE. CONTRACTOR MAY REMOVE ABANDONED CABLES AT NO ADDITIONAL COST TO THE CONTRACT AND SHALL HAVE THE SALVAGE RIGHTS TO ABANDONED CABLES.

- | | |
|---|---|
| <p>1 SERVICE CONDUIT & LB FITTING FROM UTILITY METER TO VAULT SERVICE PANEL. SEE GENERAL NOTE 2.</p> <p>2 VAULT SERVICE PANEL. SEE "VAULT SERVICE PANEL" SCHEDULE. DISCONNECT & REMOVE EXISTING FEEDER & BRANCH CIRCUITS FOR RWY 7 PAPI, RWY 25 PAPI, RWY 25 REILS, AIRPORT ROTATING BEACON, WIND SOCK, L-854 RADIO RECEIVER, RWY-7-25 CCR & PHOTOCELL. PANELBOARD SHALL REMAIN.</p> <p>3 BRANCH CIRCUIT TO CCR. TO BE REMOVED.</p> <p>4 JUNCTION BOX. TO BE REMOVED.</p> <p>5 EXPLOSION PROOF CONDUIT SEAL OFF FITTING SUITABLE FOR CLASS I, DIV. 1, GROUP D LOCATION. INSTALL AS FIRST FITTING WHERE CONDUIT EMERGES FROM THE AREA 18" ABOVE THE FLOOR. PROVIDE LTFMC AT FINAL CONNECTION TO CCR. TO BE REMOVED.</p> <p>6 CONTROL WIRING IN 3/4" GRSC. TO BE REMOVED.</p> <p>7 EXISTING INTERFACE PANEL TO BE REMOVED AND RELOCATED TO STORAGE.</p> <p>8 EXISTING L-854 RADIO CONTROL UNIT TO BE REMOVED AND RELOCATED TO STORAGE.</p> <p>9 AC SURGE PROTECTOR/TVSS TO REMAIN.</p> <p>10 BRANCH CIRCUITS FOR PAPIs, REILS, WIND CONE, BEACON, & PHOTOCELL IN 1 1/4" GRSC TO BE REMOVED.</p> <p>11 RELAY/CONTACTOR PANEL FOR CCR, PAPIs, REILS, WINDCONE & BEACON TO BE DISCONNECTED AND REMAIN IN PLACE.</p> <p>12 (RESERVED)</p> | <p>13 BYPASS SWITCH IN FS BOX WITH COVER PLATE TO BE REMOVED.</p> <p>14 CONDUITS FOR AIRFIELD LIGHTING CIRCUITS (PAPIs, REILS, WINDCONE, & BEACON). WIRING TO BE DISCONNECTED AND REMOVED.</p> <p>15 PHOTOCELL WIRING IN 3/4" GRSC. TO BE REMOVED.</p> <p>16 2 #10 THWN, 1 #10 GND IN 3/4" GRSC FOR 1500 WATT MV APRON LIGHT TO REMAIN.</p> <p>17 VAULT GROUND BUS TO REMAIN.</p> <p>18 120 VAC POWER WIRING IN 3/4" LTFMC FOR RADIO & INTERFACE PANEL TO BE REMOVED.</p> |
|---|---|

REVISION	DATE

ROCHELLE MUNICIPAL AIRPORT
MAJOR THOMAS F. KORITZ FIELD
ROCHELLE, ILLINOIS

IL PROJ.: RPJ-4136 A.I.P. PROJ.: 3-17-0087-B14

Hanson Project No. 10A0139D	File Name E-201-VLT.dwg	Scale AS SHOWN	Date 11/22/11
LAYOUT	JFC	JFC	10/21/11
DRAWN	JFC	JFC	10/21/11
REVIEWED	CHY/KNL	CHY/KNL	10/21/11

HANSON
Professional Services Inc. 2011
1525 South Sixth Street
Springfield, Illinois 62703-2886
Ph: (217) 788-2450 Fax: (217) 788-2503
www.hanson-inc.com
Offices Nationwide

**CONSTRUCT
ELECTRICAL VAULT**

**EXISTING AIRPORT VAULT
EQUIPMENT ELEVATION**

NOV 23, 2011 12:27 PM WALL00723
p:\s\spj-sv306\hanson\dom\hanson_projects\documents\10\jobs\10A0139D\CAD\Airport\Sheet\E-201-VLT

NOTES

- ALL VAULT WORK AND/OR POWER OUTAGES SHALL BE COORDINATED WITH THE AIRPORT MANAGER.
- CONTRACTOR SHALL EXAMINE SITE AND FIELD VERIFY EXISTING CONDITIONS.
- ALL VAULT WORK, POWER OUTAGES AND/OR SHUT DOWN OF EXISTING SYSTEMS SHALL BE COORDINATED WITH THE AIRPORT MANAGER. ONCE SHUT DOWN, THE CIRCUITS SHALL BE LABELED AS SUCH TO PREVENT ACCIDENTAL ENERGIZING OF THE RESPECTIVE CIRCUITS. ALL PERSONNEL SHALL FOLLOW U.S. DEPARTMENT OF LABOR OCCUPATIONAL SAFETY & HEALTH ADMINISTRATION (OSHA) 29 CFR 1910 OCCUPATIONAL SAFETY AND HEALTH STANDARDS FOR ELECTRICAL SAFETY AND LOCKOUT/TAGOUT PROCEDURES INCLUDING, BUT NOT LIMITED TO, 29 CFR SECTION 1910.147 THE CONTROL OF HAZARDOUS ENERGY (LOCKOUT/TAGOUT).
- ALL EXISTING AIRFIELD LIGHTING SYSTEMS (THAT ARE NOT SCHEDULED FOR REMOVAL AND REPLACEMENT) SHALL BE OPERABLE DURING NIGHTFALL UNLESS OTHERWISE APPROVED BY THE AIRPORT MANAGER AND/OR OTHERWISE DETAILED HEREIN. CONTRACTOR SHALL PROVIDE ALL TEMPORARY WORK AS NECESSARY TO MAINTAIN OPERATION OF THE AIRFIELD LIGHTING SYSTEMS AT NIGHTFALL. CONTRACTOR SHALL COORDINATE TRANSFER OF EXISTING AIRFIELD CIRCUITS TO MINIMIZE DOWNTIME.
- EQUIPMENT DESIGNATED FOR REMOVAL SHALL BE TURNED OVER TO THE AIRPORT. IN THE EVENT THE AIRPORT DOES NOT WANT THE RESPECTIVE EQUIPMENT, THE CONTRACTOR SHALL DISPOSE OF IT OFF SITE.
- PER NEC 513 THE ENTIRE AREA OF THE HANGAR INCLUDING ANY ADJACENT AND COMMUNICATING AREAS NOT SUITABLE CUT OFF FROM THE HANGAR, SHALL BE CLASSIFIED AS A CLASS I, DIVISION 2 HAZARDOUS LOCATION UP TO A LEVEL 18 INCHES ABOVE THE FLOOR. AREAS IN THE VICINITY OF AIRCRAFT ARE ALSO CLASSIFIED AS HAZARDOUS AS DEFINED BY NEC 513. ALL ELECTRICAL INSTALLATIONS IN CLASSIFIED HAZARDOUS LOCATIONS SHALL BE AVOIDED UNLESS SPECIFICALLY APPROVED FOR SUCH LOCATIONS AND INSTALLED IN CONFORMANCE WITH NEC 500, 501, AND 513 AS WELL AS ANY OTHER APPLICABLE CODES AND REQUIREMENTS.
- COORDINATE ELECTRIC SERVICE WORK WITH THE SERVING ELECTRIC UTILITY ATTN.: MR. JOE ORLIKOWSKI
TRANSMISSION & DISTRIBUTION DIVISION
ROCHELLE MUNICIPAL UTILITIES
P.O. BOX 456
ROCHELLE, ILLINOIS 61068
PHONE: 815-561-2040
- CABLING MADE OBSOLETE BY PROPOSED WORK SHALL BE REMOVED.
- EXISTING RUNWAY 7-25 CCR TO BE RELOCATED TO NEW VAULT. ALL ASSOCIATED CABLING AND CONDUITS SHALL BE DISCONNECTED AND REMOVED.
- REMOVAL OF EXISTING VAULT EQUIPMENT, MATERIALS, CABLING AND ASSOCIATED WORK WILL BE PAID FOR UNDER ITEM AR109902 REMOVE ELECTRICAL EQUIPMENT PER LUMP SUM.

EXISTING VAULT SERVICE PANEL			
CKT #	DUTY	SIZE	CKT #
1	SPARE	20A 1P	2
3	RADIO & RELAY INTERFACE	15A 1P	4
5	RUNWAY 7 PAPI UNIT	20A 2P	6
7			8
9	RUNWAY 25 PAPI UNIT	20A 2P	10
11			12
13	RUNWAY 25 REILS	15A 2P	14
15			16
17	SPARE	15A 1P	18
19	SPARE	20A 1P	20
21	SPARE	15A 2P	22
23			24
25	SPARE	20A 2P	26
27			28
29	BLANK		30

225 AMP, 120/240 VAC, 1 PHASE, 3 WIRE, 30 CKT PANELBOARD WITH 200AMP, 2 POLE MAIN BREAKER IN A 14" WIDE NEMA 1 SURFACE MOUNT ENCLOSURE; SQUARE D NQOD30L225CU.

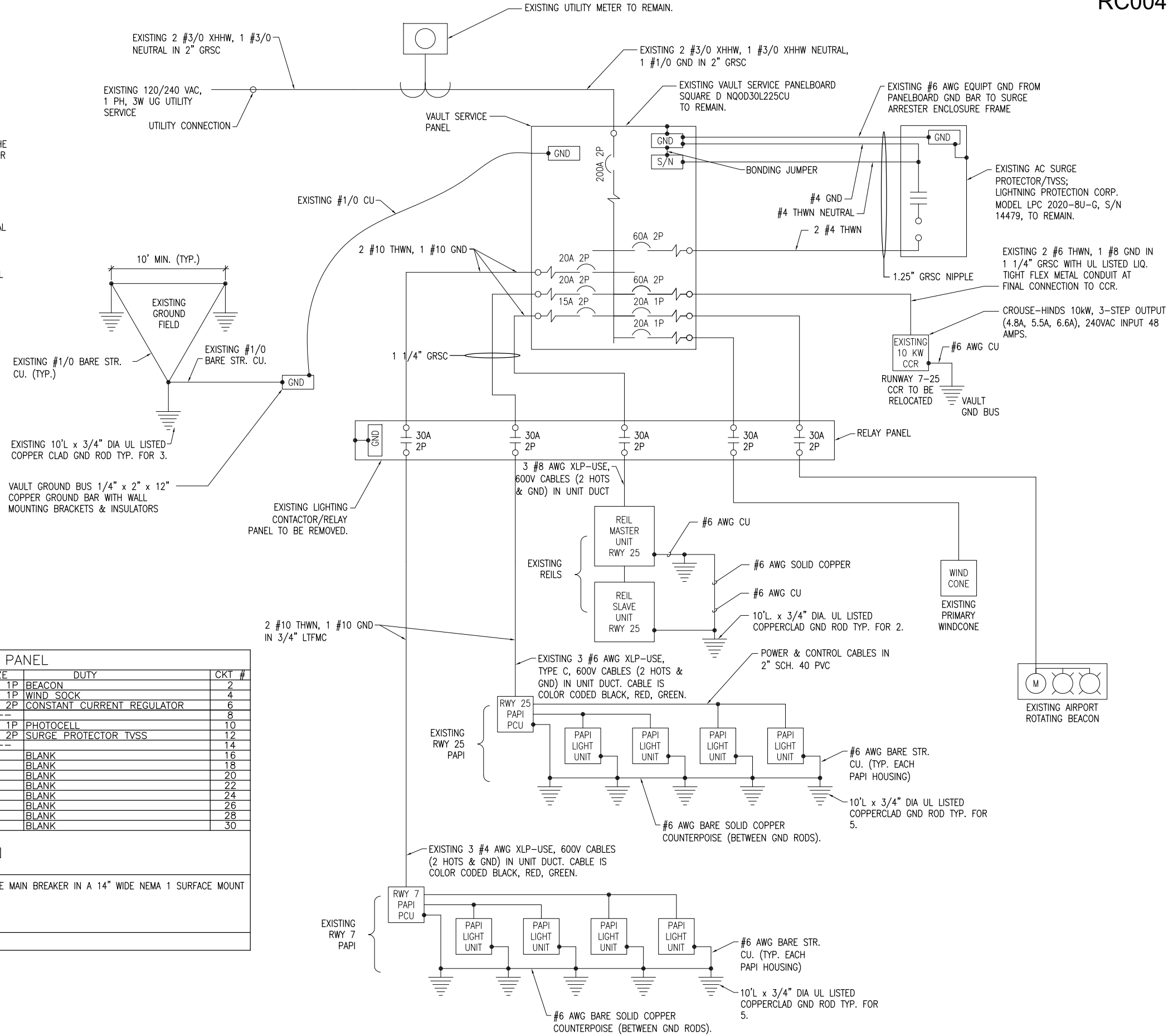

EXISTING ELECTRICAL ONE LINE FOR VAULT & AIRFIELD

REVISION	
DATE	
ROCHELLE MUNICIPAL AIRPORT MAJOR THOMAS F. KORITZ FIELD ROCHELLE, ILLINOIS	
Project No. 10A0139D Filename E-601-WRG.dwg Scale AS SHOWN Date 11/22/11	LAYOUT JFC 10/21/11 DRAWN JFC 10/21/11 REVIEWED CAH/KNL 10/21/11
HANSON Professional Services Inc. 2011 1525 South Sixth Street Springfield, Illinois 62703-2886 Ph: (217) 788-2450 Fax: (217) 788-2503 www.hanson-inc.com Offices Nationwide	
CONSTRUCT ELECTRICAL VAULT	EXISTING ELECTRICAL ONE-LINE DIAGRAM
11 11 of 24 sheets	

NOV 23, 2011 12:30 PM WALLE00723
 p:\s\sgl-svr306.hanson.com\Projects\Documents\10A0139D\CAD\Airport\Sheet\E-601-WRG

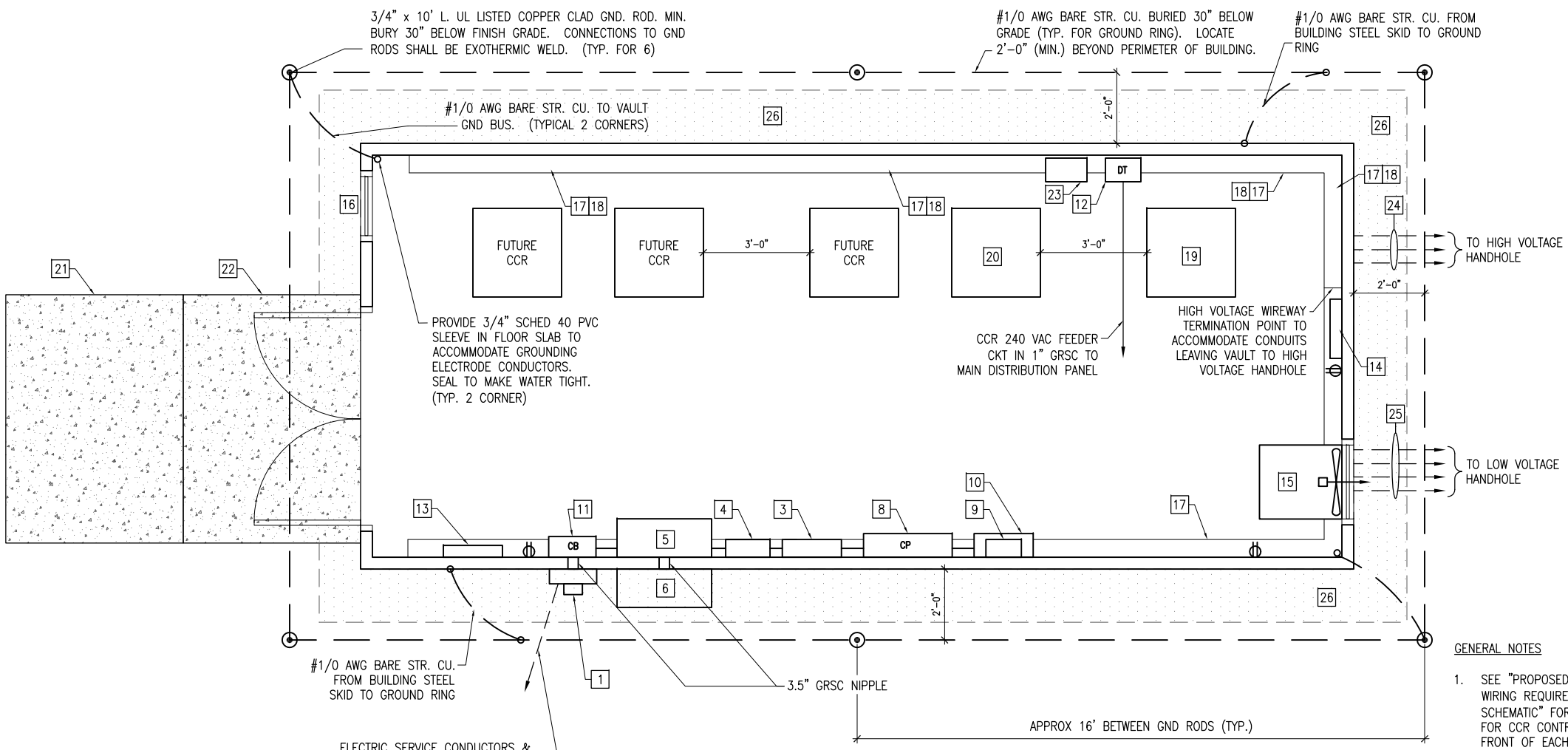

ELECTRICAL LEGEND - PLANS	
	CONDUIT (EXPOSED)
	CONDUIT OR UNIT DUCT (CONCEALED OR BURIED)
	POLE OR CONDUIT MOUNTED LIGHT FIXTURE
	WALL OR CEILING MTD. JUNCTION BOX. CONFIGURATION VARIES WITH USE
	SINGLE THROW DISCONNECT SWITCH
	SINGLE THROW, FUSIBLE DISCONNECT SWITCH
	ENCLOSED CIRCUIT BREAKER
	DOUBLE THROW SAFETY SWITCH, MANUAL TRANSFER SWITCH
	CONTROL PANEL
	TRANSFORMER
	ELECTRIC UTILITY METER
	ENCLOSURE
	CIRCUIT BREAKER PANEL-SEE SCHEDULES
	GROUND ROD
	#12 AWG TWN COPPER UNLESS NOTED OTHERWISE. LONG SLASHES INDICATE NEUTRAL. SHORT SLASHES INDICATE HOT OR SWITCHED LEG. SLASHES WITH DOT OR A "G" INDICATE SEPARATE GROUND WIRE.
	HOMERUN TO PANEL PNL A INDICATES PANEL 1,3,5 INDICATES CIRCUIT NUMBERS
	PHOTO-ELECTRIC CELL

GENERAL NOTES

- SEE "PROPOSED ELECTRICAL ONE-LINE FOR VAULT AND AIRFIELD" FOR LOW VOLTAGE INPUT POWER WIRING REQUIREMENTS TO CCR'S (CONSTANT CURRENT REGULATORS). SEE "HIGH VOLTAGE WIRING SCHEMATIC" FOR CCR OUTPUT WIRING REQUIREMENTS. SEE "AIRFIELD LIGHTING WIRING SCHEMATIC" FOR CCR CONTROL WIRING REQUIREMENTS. PROVIDE 5 FEET MINIMUM CLEAR WORKING SPACE IN FRONT OF EACH CCR AND EACH SERIES PLUG CUTOUT.
- CONSTANT CURRENT REGULATORS AND THEIR RESPECTIVE SERIES PLUG CUTOUTS SHALL BE CLEARLY LABELED TO IDENTIFY THE RESPECTIVE REGULATOR DESIGNATION, RUNWAY OR TAXIWAY SERVED, POWER SOURCE OR CIRCUIT, AND VOLTAGE SYSTEM.
- SEE ELEVATION VIEWS FOR ADDITIONAL INFORMATION ON PROPOSED EQUIPMENT LAYOUTS.
- COORDINATE CONDUIT & SLEEVE ENTRANCES THROUGH FLOOR SLAB AND WALLS.

VAULT ELECTRICAL EQUIPMENT PLAN
SCALE 1/2"=1'-0" [FULL-SIZE (22x34)]

KEYED NOTES

- | | | |
|--|---|--|
| <p>1 ELECTRIC UTILITY METER WITH SUPPORT HARDWARE PER SERVING ELECTRIC UTILITY COMPANY REQUIREMENTS.</p> <p>2 UTILITY SERVICE CONDUCTORS IN CONDUIT FROM UTILITY TRANSFORMER TO METER BASE BY UTILITY. CONTRACTOR SHALL FURNISH & INSTALL SERVICE CONDUCTORS & CONDUIT FROM METER BASE TO SERVICE PANEL. SEE "NEW VAULT ELECTRICAL ONE LINE DIAGRAM".</p> <p>3 SERVICE PANEL A, SEE PANEL A SCHEDULE.</p> <p>4 AC SURGE PROTECTIVE DEVICE, SEE "PROPOSED ELECTRICAL ONE-LINE FOR VAULT AND AIRFIELD."</p> <p>5 NEW 400 AMP, 120/240 VAC 1 PHASE AUTO TRANSFER SWITCH IN A NEMA 12 ENCLOSURE WITH DOOR HINGE ON RIGHT HAND SIDE. (AS109800) (ADDITIVE ALTERNATE BID)</p> <p>6 400 AMP, 120/240 VAC, 1 PH, 3W PORTABLE GENERATOR QUICK CONNECT (AS109800).</p> <p>7 NOT USED.</p> <p>8 LIGHTING CONTACTOR PANEL. SEE AIRFIELD LIGHTING WIRING SCHEMATIC AND LIGHTING CONTACTOR PANEL DETAIL.</p> <p>9 L-854 RADIO CONTROL UNIT. EXTEND GRSC & RADIO ANTENNA CABLE AND MOUNT ANTENNA ABOVE THE VAULT BUILDING ROOF AS REQUIRED FOR PROPER OPERATION. BOND GRSC AT BLDG EXTERIOR TO GND RING WITH #2 AWG BARE CU. PROVIDE 1" SCHED 40 PVC TO PROTECT GND WIRE. GRSC WITH ANTENNA CABLE SHALL TRANSITION TO SCHED 40 PVC AT ENTRY TO VAULT.</p> <p>10 RADIO RELAY INTERFACE PANEL WITH PHOTOCCELL BYPASS SWITCH FOR AIRFIELD LIGHTING SYSTEM. SEE AIRFIELD LIGHTING WIRING SCHEMATIC FOR WIRING REQUIREMENTS. MOUNT PHOTOCCELL ON ROOF. FIELD VERIFY LOCATION FOR PROPER CONTROL AND OPERATION.</p> <p>11 240 VAC, 400 AMP, 2-POLE SERVICE BREAKER IN A NEMA 1 ENCLOSURE UL LISTED SUITABLE FOR SERVICE ENTRANCE. COORDINATE LOCATION TO PROVIDE PROPER WORKING CLEARANCE.</p> <p>12 100AMP, 240VAC, 2P DOUBLE THROW NOT FUSIBLE SAFETY SWITCH FOR CCR'S. SEE VAULT EQUIPMENT ELEVATIONS FOR PROPOSED VS. FUTURE EQUIPMENT TO BE INSTALLED.</p> | <p>13 ELECTRIC WALL HEATER EH-1, 4000 WATT, 240 VAC, 1 PHASE, SUITABLE FOR SURFACE MOUNTING WITH INTEGRAL THERMOSTAT, Q-MARK MODEL CWH3404, OR EQUAL. HEATER SHALL BE MANUFACTURED IN THE UNITED STATES TO COMPLY WITH THE AIRPORT IMPROVEMENT PROGRAM BUY AMERICAN REQUIREMENT, & THE "BUY AMERICAN ACT"</p> <p>14 ELECTRIC WALL HEATER EH-2 4000 WATT, 240 VAC, 1 PHASE, SUITABLE FOR SURFACE MOUNTING WITH INTEGRAL THERMOSTAT, Q-MARK MODEL CWH3404 OR APPROVED EQUAL. HEATER SHALL BE MANUFACTURED IN THE UNITED STATES TO COMPLY WITH THE AIRPORT IMPROVEMENT PROGRAM BUY AMERICAN REQUIREMENT, & "BUY AMERICAN ACT". BOTTOM OF HEATER SHALL BE 3" (MIN.) ABOVE THE UPPER ELECTRICAL WIREWAY. COORDINATE WITH CCR INSTALLATION & FAN INSTALLATION. LOCATE HEATER ON WALL SUCH THAT IT IS NOT DIRECTLY BEHIND CCR.</p> <p>15 EXHAUST FAN EF-1, 3100 CFM (MINIMUM) AT .25" STATIC PRESSURE WITH 1/3 HP (MINIMUM), 120 VAC MOTOR, COOK MODEL 20S10D, OR APPROVED EQUAL. INCLUDE WALL HOUSING WITH GUARD, GRAVITY BACK DRAFT DAMPER, ALUMINUM WEATHER-HOOD PAINTED TO MATCH BUILDING EXTERIOR, STAINLESS STEEL INSECT SCREEN, AND FRACTIONAL HP ELECTRICAL DISCONNECT. INSTALL FAN AS HIGH AS POSSIBLE. PROVIDE 120 VAC THERMOSTAT, AT 48" AFF. SEE EXHAUST FAN CONTROL SCHEMATIC FOR WIRING REQUIREMENTS. FAN SHALL BE MANUFACTURED IN THE UNITED STATES TO COMPLY WITH THE AIRPORT IMPROVEMENT PROGRAM BUY AMERICAN REQUIREMENT, & THE "BUY AMERICAN ACT".</p> <p>16 INTAKE LOUVER L-1, 24" WIDE BY 48" HIGH INTAKE LOUVER WITH STAINLESS INSECT SCREEN. 120 VAC MOTORIZED DAMPER DWITH LIMIT SWITCH, KYNAR FINISH MATCHING BUILDING EXTERIOR, RUSKIN MODEL ELF375DX, OR APPROVED EQUAL. SEE EXHAUST FAN CONTROL SCHEMATIC FOR WIRING REQUIREMENTS. LOUVER / DAMPER SHALL BE MANUFACTURED IN THE UNITED STATES TO COMPLY WITH THE AIRPORT IMPROVEMENT PROGRAM BUY AMERICAN REQUIREMENT, & THE "BUY AMERICAN ACT".</p> <p>17 6" BY 6" LOW VOLTAGE WIREWAY. LABEL "LOW VOLTAGE" EVERY 4 FEET. INSTALL ABOVE HIGH VOLTAGE WIREWAY.</p> <p>18 6" BY 6" HIGH VOLTAGE WIREWAY. LABEL "HIGH VOLTAGE" EVERY 4 FEET. INSTALL BELOW LOW VOLTAGE WIREWAY.</p> <p>19 NEW RUNWAY 7-25 CONSTANT CURRENT REGULATOR. SEE GENERAL NOTE 1.</p> <p>20 BACKUP/SPARE CONSTANT CURRENT REGULATOR FOR RUNWAY 7-25 RELOCATED FROM EXISTING VAULT. SEE NOTE 1.</p> | <p>21 ENTRANCE PAD/STEP CONSTRUCTED OF 6" CONCRETE SLAB W/6X6-W5XW5 WELDED WIRE FABRIC ON A COMPACTED SUBGRADE. MINIMUM DIMENSIONS OF PAD WILL BE 7'Wx5'Dx6"H, SLOPED AT A MIN. OF 0.5"/FT AWAY FROM THE VAULT ENTRANCE. PCC USED TO CONSTRUCT THE PAD WILL CONFORM TO ITEM 610. ALL MATERIALS, LABOR AND EQUIPMENT USED TO CONSTRUCT THE PAD INCLUDING ANY GRADING REQUIRED WILL BE CONSIDERED INCIDENTAL TO THE CONSTRUCTION OF THE PROPOSED ELECTRICAL VAULT AND NO ADDITIONAL COMPENSATION WILL BE ALLOWED.</p> <p>22 SECOND PAD/STEP CONSTRUCTED OF 12" CONCRETE SLAB W/6X6-W5XW5 WELDED WIRE FABRIC ON A COMPACTED SUBGRADE. MINIMUM DIMENSIONS OF PAD WILL BE 7'Wx5'Dx12"H, SLOPED AT A MIN. OF 0.5"/FT AWAY FROM THE VAULT ENTRANCE. PCC USED TO CONSTRUCT THE PAD WILL CONFORM TO ITEM 610. ALL MATERIALS, LABOR AND EQUIPMENT USED TO CONSTRUCT THE PAD INCLUDING ANY GRADING REQUIRED WILL BE CONSIDERED INCIDENTAL TO THE CONSTRUCTION OF THE PROPOSED ELECTRICAL VAULT AND NO ADDITIONAL COMPENSATION WILL BE ALLOWED. COORDINATE WITH ENTRY TO VAULT. VAULT FLOOR ELEVATION TO BE APPROXIMATELY 6 INCHES ABOVE SECOND STEP.</p> <p>23 TRANSFER PAIR SERIES PLUG CUTOUTS (TYPE S-1) WITH ENCLOSURE. SEE GENERAL NOTES 1 & 2.</p> <p>24 3-3" PVC COATED GRSC WITH PVC COATED GRSC ELBOWS FROM HIGH VOLTAGE WIREWAY TO HIGH VOLTAGE HANDHOLE.</p> <p>25 4-3" PVC COATED GRSC WITH 4-3" PVC COATED GRSC ELBOWS AT VAULT FROM LOW VOLTAGE WIREWAY TO LOW VOLTAGE HANDHOLE.</p> <p>26 VEGETATION BARRIER CONSISTING OF A MIN. 3" PEA GRAVEL SURFACE OVER FILTER OR LANDSCAPING FABRIC. PROPOSED SURFACE TREATMENT WILL COVER ENTIRE AREA BENEATH VAULT STRUCTURE AS WELL AS 18" AROUND THE PERIMETER OF THE BUILDING EDGE. THE STONE AND FABRIC AS WELL AS ANY EQUIPMENT AND LABOR REQUIRED TO COMPLETE THIS TASK WILL BE CONSIDERED INCIDENTAL TO THE INSTALLATION OF THE PROPOSED ELECTRICAL VAULT AND NO ADDITIONAL COMPENSATION WILL BE ALLOWED.</p> |
|--|---|--|

REVISION					
DATE					
<p>ROCHELLE MUNICIPAL AIRPORT MAJOR THOMAS F. KORITZ FIELD ROCHELLE, ILLINOIS</p>					
<p>IL PROJ.: RPJ-4136 A.I.P. PROJ.: 3-17-0087-B14</p>					
Hanson Project No. 10A01390	E-103-VLT.dwg	AS SHOWN	11/22/11	10/21/11	10/21/11
LAYOUT	JFC	JFC	JFC	CAN/KNL	10/21/11
DRAWN	JFC	JFC	JFC	CAN/KNL	10/21/11
REVIEWED	CAN/KNL	CAN/KNL	CAN/KNL	CAN/KNL	10/21/11
<p>HANSON Professional Services Inc. 2011 1525 South Sixth Street Springfield, Illinois 62703-2886 Ph: (217) 788-2450 Fax: (217) 788-2503 www.hanson-inc.com Offices Nationwide</p>					
<p>CONSTRUCT ELECTRICAL VAULT</p>			<p>PROPOSED AIRPORT VAULT EQUIPMENT PLAN</p>		
<p>12</p> <p>12 of 24 sheets</p>					

NOV 23, 2011 12:31 PM WALLE00723
 P:\s\sp\306\hanson\dom\hanson\Projects\Documents\10A01390\10A01390 CAD\Airport\Sheet\E-103-VLT

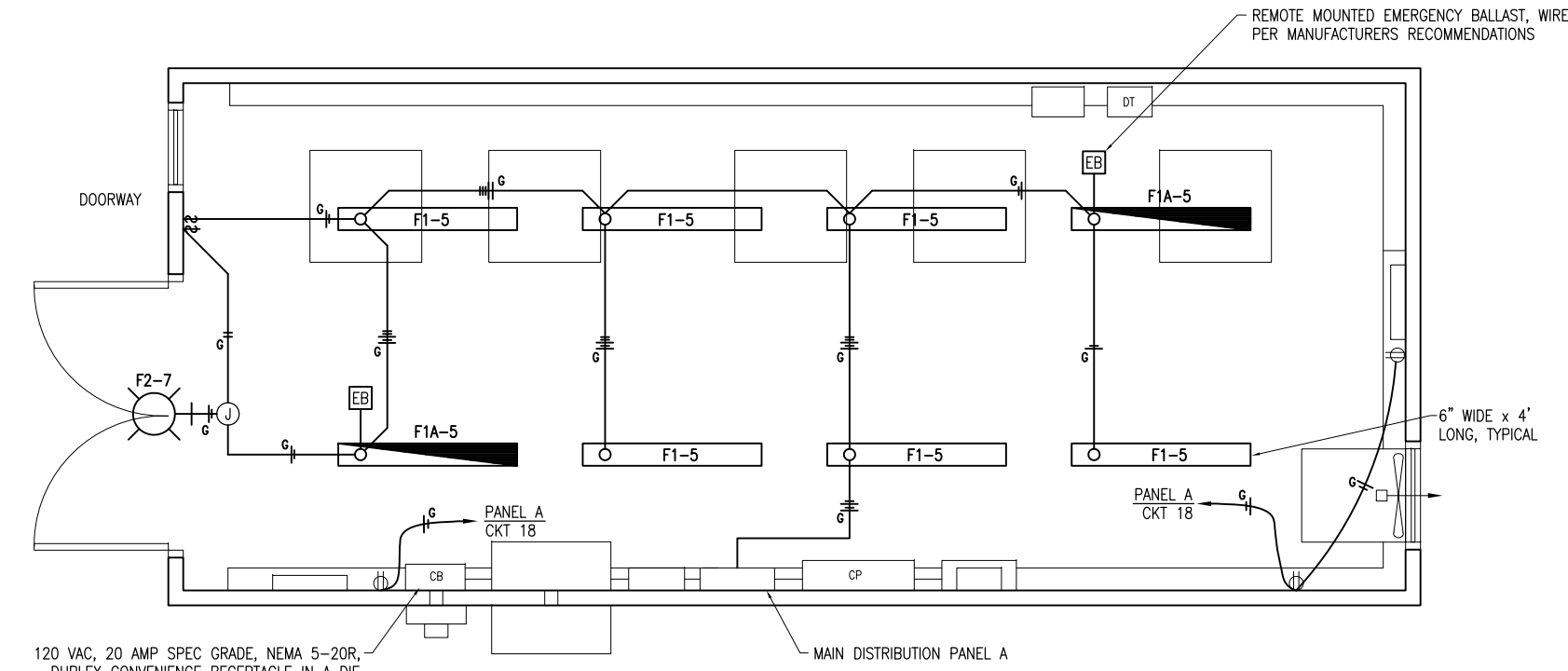

120 VAC, 20 AMP SPEC GRADE, NEMA 5-20R, DUPLEX CONVENIENCE RECEPTACLE IN A DIE CAST CONSTRUCTION HUBBELL/RACO/BELL, APPLETON, CROUSE-HINDS, OR APPROVED EQUAL WEATHERPROOF OUTLET BOX WITH STAINLESS STEEL COVER PLATE (TYP.)

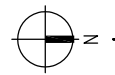

VAULT LIGHTING & RECEPTACLE PLAN

SCALE 1/2"=1'-0" [FULL-SIZE (22x34)]
1 0 2 4 FEET

NOTES

- 15 AMP & 20 AMP BRANCH CIRCUITS FOR LIGHTING & RECEPTACLES SHALL USE #12 AWG THWN (MIN.). EMT MAY BE USED FOR LIGHTING AND RECEPTACLE BRANCH CIRCUITS.
- LIGHT FIXTURES SHALL BE MANUFACTURED IN THE UNITED STATES TO COMPLY WITH THE AIRPORT IMPROVEMENT PROGRAM BUY AMERICAN REQUIREMENTS. PROVIDE CERTIFICATION OF MANUFACTURE IN THE UNITED STATES WITH SHOP DRAWINGS SUBMITTAL.
- ADJUST RECEPTACLE LOCATIONS WHERE NECESSARY TO ACCOMMODATE EQUIPMENT LAYOUT.
- TEST EMERGENCY LIGHTING AND CONFIRM PROPER OPERATION.
- "USPOM" SUFFIX ON LITHONIA LIGHT FIXTURE CATALOG NUMBERS INDICATES UNITED STATES POINT OF MANUFACTURE.

LIGHTING FIXTURE SCHEDULE						
FIXT. TYPE	DESCRIPTION	MANUFACTURER & CATALOG NO.	LAMPS/WATTS	VOLTS	MOUNTING	REMARKS
F1	4 FT. WET LOCATION LISTED ENCLOSED AND GASKETED INDUSTRIAL FLUORESCENT LIGHT FIXTURE, IMPACT RESISTANT, UV RESISTANT REINFORCED POLYESTER FIBERGLASS HOUSING, HIGH IMPACT ACRYLIC DIFFUSER, RAPID START COLD WEATHER 0 DEG. F. ELECTRONIC BALLAST WITH LESS THAN OR EQUAL TO 10% THD.	LITHONIA: DMW-2-32-AR-120- CW-GE10RS-WLF -USPOM	2-32W T8 4100K 59 TOTAL INPUT WATTS	120	SURFACE TO HARD CEILING	PROVIDE WET LOCATION FITTINGS INSTALLED IN TOP OF FIXTURE.
F1A	SAME AS F1 EXCEPT PROVIDE AN EMERGENCY BALLAST CAPABLE OF OPERATING 2 LAMPS FOR 90 MINUTES AT 1100-1400 TOTAL LUMENS, BODINE #B50ST. NOTE BALLAST MIGHT REQUIRE TO BE REMOTE MOUNTED NEAR FIXTURE AS INDICATED ON THE PLANS.	LITHONIA: DMW-2-32-AR-120- CW-GE10RS-WLF -USPOM	2-32W T8 4100K 59 TOTAL INPUT WATTS	120	SURFACE TO HARD CEILING	PROVIDE WET LOCATION FITTINGS INSTALLED IN TOP OF FIXTURE.
F2	COMPACT FLUORESCENT WALL-PAK, ONE PIECE INJECTION MOLDED UV STABILIZED POLYCARBONATE HOUSING, HIGH PERFORMANCE SPECULAR ANODIZED SEGMENTED REFLECTOR, ONE PIECE HIGH TEMPERATURE SILICONE GASKET, MEDIUM BRONZE FINISH, HIGH POWERFACTOR ELECTRONIC BALLAST WITH LESS THAN OR EQUAL TO 10% THD, UL LISTED FOR WET LOCATIONS, FUSED.	LITHONIA: TWA-42TRT-120-SF- CR-DMB-LPI -USPOM	1-42W TRT 4100K 47 TOTAL INPUT WATTS	120	SURFACE TO WALL ABOVE EXTERIOR DOOR APPROXIMATELY 4 INCHES ABOVE TOP OF DOOR FRAME.	CONNECT TO WALL SWITCH LOCATED ON THE INSIDE OF THE BUILDING.

REVISION	DATE

ROCHELLE MUNICIPAL AIRPORT
MAJOR THOMAS F. KORITZ FIELD
ROCHELLE, ILLINOIS

IL PROJ.: RPJ-4136 A.I.P. PROJ.: 3-17-0087-B14

Hanson Project No. 10A0139D	File Name E-105-LTG.dwg	Scale AS SHOWN	Date 11/22/11
LAYOUT	JFC	JFC	10/21/11
DRAWN	JFC	JFC	10/21/11
REVIEWED	CHY/KNL	CHY/KNL	10/21/11

HANSON
Professional Services Inc. 2011
Hanson Professional Services Inc.
1525 South Sixth Street
Springfield, Illinois 62703-2886
Ph: (217) 788-2450 Fax: (217) 788-2503
www.hanson-inc.com
Offices Nationwide

**CONSTRUCT
ELECTRICAL VAULT**

PROPOSED VAULT LIGHTING
AND RECEPTACLE PLAN

NOV 23, 2011 12:32 PM WALLE00723
pw:\sps-svr306\hanson.dom\hanson_projects\Documents\10A0139D\10A0139D\CAD\Airport\Sheet\E-105-LTG

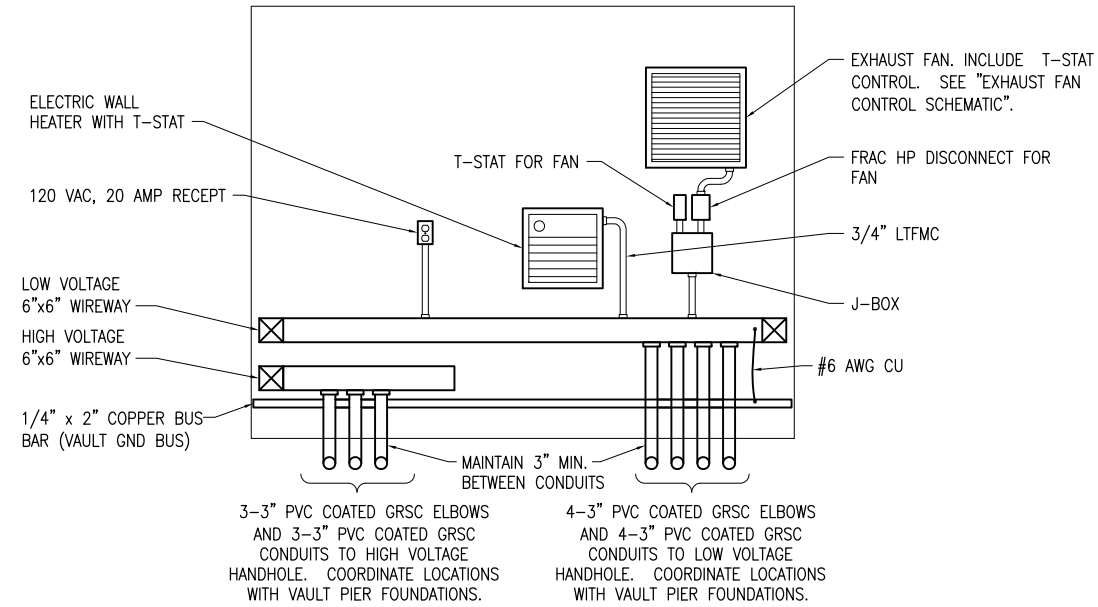

VAULT NORTH WALL ELEVATION

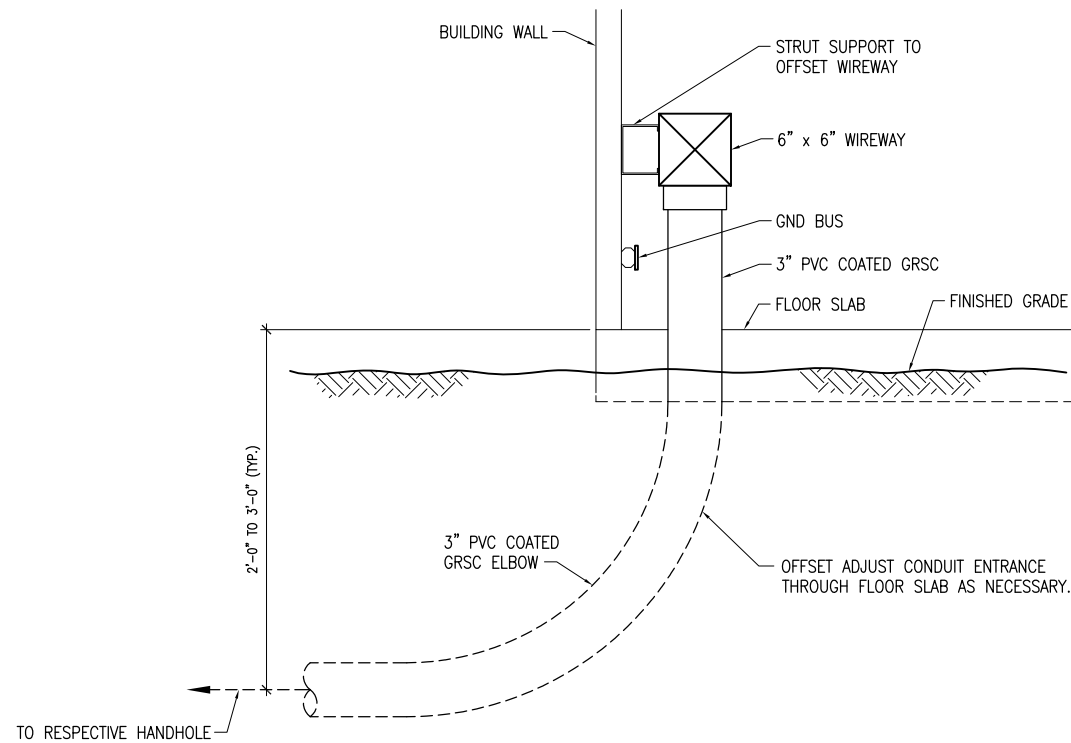
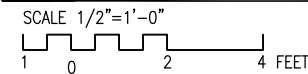

CONDUIT ENTRANCE DETAIL

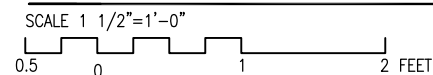

VAULT MAIN DISTRIBUTION PANEL "A" SCHEDULE

CKT #	DUTY	SIZE	SIZE	DUTY	CKT #
1	AC SURGE PROTECTOR / TVSS	60A	60A	RUNWAY 7-25 CCR'S	2
3		2P	2P		4
5	RUNWAY 7 PAPI	20A	60A	SPARE RUNWAY CCR CKT	6
7		2P	2P		8
9	RUNWAY 25 PAPI	20A	20A 1P	SPARE	10
11		2P	20A 1P	SPARE	12
13	WIND CONE	20A 1P	20A 1P	VAULT INTERIOR LIGHTS	14
15	AIRPORT ROTATING BEACON	30A	20A 1P	VAULT EXTERIOR LIGHTS	16
17		2P	20A 1P	VAULT RECEPTACLES	18
19	RUNWAY 25 REILS	20A	20A 1P	L-854 RADIO & CONTROL POWER	20
21		2P	20A 1P	VAULT EXHAUST FAN	22
23	SPARE	20A			24
25		2P			26
27	ELECTRIC HEATER #1	25A	20A 1P	NON-DIRECTIONAL BEACON (NDB)	28
29		2P	20A 1P	SPARE	30
31	ELECTRIC HEATER #2	25A	20A 1P	SPARE	32
33		2P	20A 1P	SPARE	34
35	SPARE	30A	---	BLANK	36
37		2P	---	BLANK	38
39	BLANK	---	---	BLANK	40
41	BLANK	---	---	BLANK	42

GND
S/N
GND

400 AMP, 120/240 VAC, 1 PHASE, 3 WIRE, 42 CIRCUIT PANELBOARD WITH 400 AMP, 2 POLE MAIN BREAKER, RATED 22,000 AIC AT 240 VAC IN A NEMA 1 ENCLOSURE, UL LISTED SUITABLE FOR SERVICE ENTRANCE. INCLUDE TWO SEPARATE COPPER GROUND BAR KITS. ALL FEEDER AND BRANCH BREAKERS SHALL BE BOLT-ON TYPE WITH 10,000 AIC RATING (MINIMUM) AT 120/240 VAC. PANELBOARD SHALL BE SQUARE D NQ TYPE OR APPROVED EQUAL.

NOTES

- PANELBOARD BUSES SHALL BE COPPER. NEUTRAL SHALL BE COPPER. EQUIPMENT GROUND BAR SHALL BE COPPER.
- ALL BRANCH CIRCUIT & FEEDER BREAKERS SHALL BE BOLT-ON TYPE WITH 10,000 AIC AT 120/240 VAC.
- INCLUDE ENGRAVED, PHENOLIC OR PLASTIC LEGEND PLATE LABELED "VAULT MAIN DIST. PANEL A, 120/240 VAC, 1PH, 3W". INCLUDE ADDITIONAL LEGEND PLATE FOR THE EXTERIOR VAULT MAIN BREAKER LABELED "VAULT MAIN DISCONNECT".
- PANELBOARD SHALL BE MANUFACTURED IN THE UNITED STATES TO COMPLY WITH THE AIRPORT IMPROVEMENT PROGRAM BUY AMERICAN REQUIREMENTS. PROVIDE CERTIFICATION OF MANUFACTURE IN THE UNITED STATES WITH SHOP DRAWING SUBMITTAL.
- CIRCUIT BREAKERS AND WIRING SHALL BE SIZED FOR THE ACTUAL EQUIPMENT FURNISHED IN CONFORMANCE WITH THE RESPECTIVE MANUFACTURER'S RECOMMENDATION AND N.E.C. CONTRACTOR SHALL ADJUST CIRCUIT BREAKER SIZES & WIRING WHERE APPLICABLE TO CONFORM WITH THE MANUFACTURER'S RECOMMENDATIONS AND N.E.C.

REVISION

DATE

ROCHELLE MUNICIPAL AIRPORT
MAJOR THOMAS F. KORITZ FIELD
ROCHELLE, ILLINOIS

IL PROJ.: RPJ-4136 A.I.P. PROJ.: 3-17-0087-B14

Hanson Project No. 10A0139D

Filename E-203-ELV.dwg

Scale AS SHOWN

Date 11/22/11

LAYOUT JFC 10/21/11

DRAWN JFC 10/21/11

REVIEWED CHY/KNL 10/21/11



© Copyright Hanson Professional Services Inc. 2011
Hanson Professional Services Inc.
 1525 South Sixth Street
 Springfield, Illinois 62703-2886
 Ph: (217) 788-2450 Fax: (217) 788-2503
 www.hanson-inc.com
 Offices Nationwide

CONSTRUCT
ELECTRICAL VAULT

PROPOSED AIRPORT VAULT
ELEVATIONS (SHEET 1)

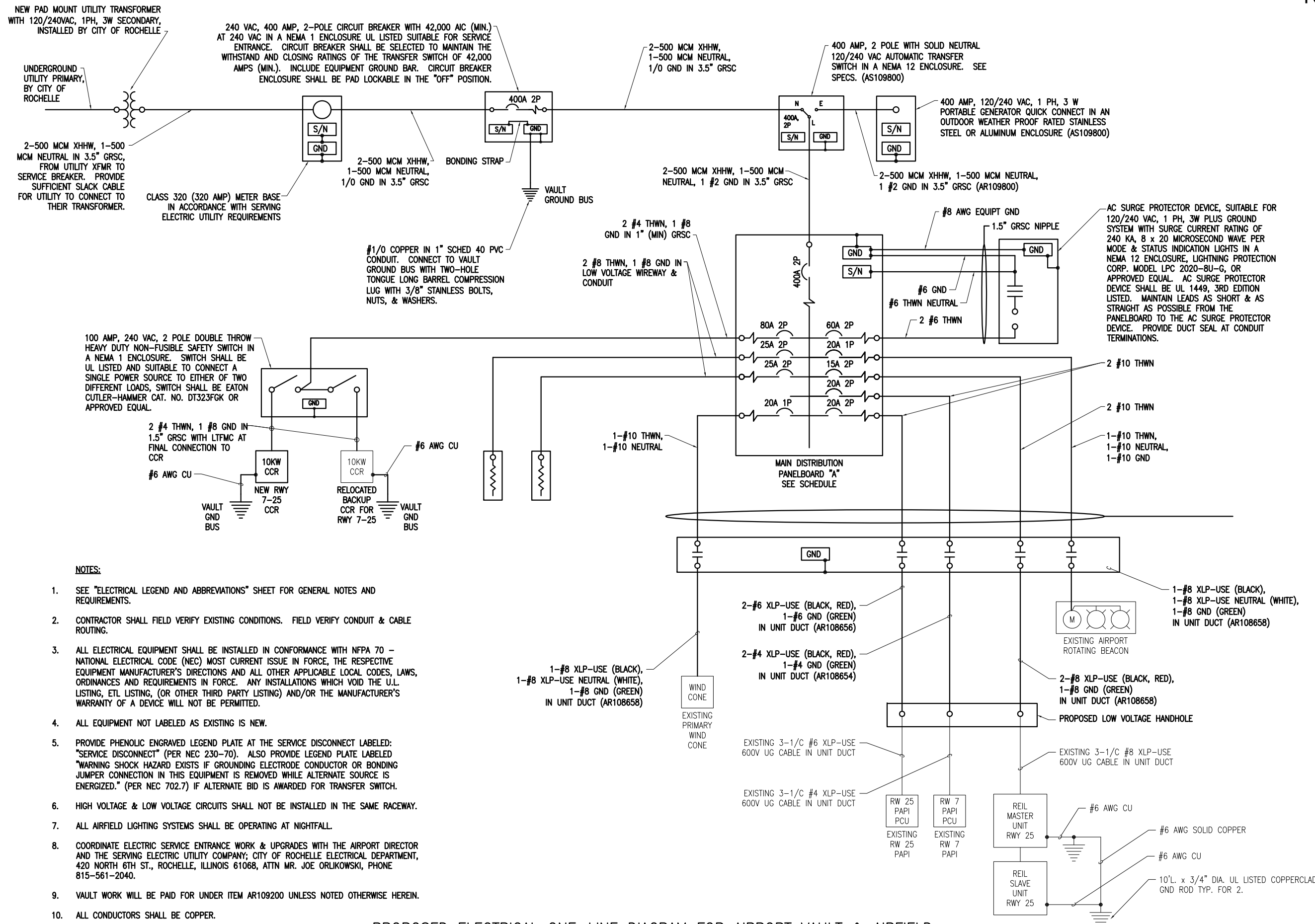

NOTES:

1. SEE "ELECTRICAL LEGEND AND ABBREVIATIONS" SHEET FOR GENERAL NOTES AND REQUIREMENTS.
2. CONTRACTOR SHALL FIELD VERIFY EXISTING CONDITIONS. FIELD VERIFY CONDUIT & CABLE ROUTING.
3. ALL ELECTRICAL EQUIPMENT SHALL BE INSTALLED IN CONFORMANCE WITH NFPA 70 - NATIONAL ELECTRICAL CODE (NEC) MOST CURRENT ISSUE IN FORCE, THE RESPECTIVE EQUIPMENT MANUFACTURER'S DIRECTIONS AND ALL OTHER APPLICABLE LOCAL CODES, LAWS, ORDINANCES AND REQUIREMENTS IN FORCE. ANY INSTALLATIONS WHICH VOID THE U.L. LISTING, ETL LISTING, (OR OTHER THIRD PARTY LISTING) AND/OR THE MANUFACTURER'S WARRANTY OF A DEVICE WILL NOT BE PERMITTED.
4. ALL EQUIPMENT NOT LABELED AS EXISTING IS NEW.
5. PROVIDE PHENOLIC ENGRAVED LEGEND PLATE AT THE SERVICE DISCONNECT LABELED: "SERVICE DISCONNECT" (PER NEC 230-70). ALSO PROVIDE LEGEND PLATE LABELED "WARNING SHOCK HAZARD EXISTS IF GROUNDING ELECTRODE CONDUCTOR OR BONDING JUMPER CONNECTION IN THIS EQUIPMENT IS REMOVED WHILE ALTERNATE SOURCE IS ENERGIZED." (PER NEC 702.7) IF ALTERNATE BID IS AWARDED FOR TRANSFER SWITCH.
6. HIGH VOLTAGE & LOW VOLTAGE CIRCUITS SHALL NOT BE INSTALLED IN THE SAME RACEWAY.
7. ALL AIRFIELD LIGHTING SYSTEMS SHALL BE OPERATING AT NIGHTFALL.
8. COORDINATE ELECTRIC SERVICE ENTRANCE WORK & UPGRADES WITH THE AIRPORT DIRECTOR AND THE SERVING ELECTRIC UTILITY COMPANY; CITY OF ROCHELLE ELECTRICAL DEPARTMENT, 420 NORTH 6TH ST., ROCHELLE, ILLINOIS 61068, ATTN MR. JOE ORLIKOWSKI, PHONE 815-561-2040.
9. VAULT WORK WILL BE PAID FOR UNDER ITEM AR109200 UNLESS NOTED OTHERWISE HEREIN.
10. ALL CONDUCTORS SHALL BE COPPER.

PROPOSED ELECTRICAL ONE-LINE DIAGRAM FOR AIRPORT VAULT & AIRFIELD

REVISION	DATE

ROCHELLE MUNICIPAL AIRPORT
 MAJOR THOMAS F. KORITZ FIELD
 ROCHELLE, ILLINOIS

IL PROJ.: RPJ-4136 A.I.P. PROJ.: 3-17-0087-B14

Hanson Project No. 10A0139D	File Name E-602-WRG.dwg	Scale AS SHOWN	Date 11/22/11
LAYOUT	JFC	10/21/11	
DRAWN	JFC	10/21/11	
REVIEWED	CAH/KNL	10/21/11	

HANSON
 Professional Services Inc. 2011
 Hanson Professional Services Inc.
 1525 South Sixth Street
 Springfield, Illinois 62703-2886
 Ph: (217) 788-2450 Fax: (217) 788-2503
 www.hanson-inc.com
 Offices Nationwide

CONSTRUCT
 ELECTRICAL VAULT

PROPOSED ELECTRICAL
 ONE-LINE FOR VAULT
 AND AIRFIELD

NOV 23, 2011 12:35 PM WALLE00723
 pw:\sgr-svr306\hanson\dom\hanson\Projects\Documents\10A0139D\10A0139D\CAD\Airport\Sheet\E-602-WRG

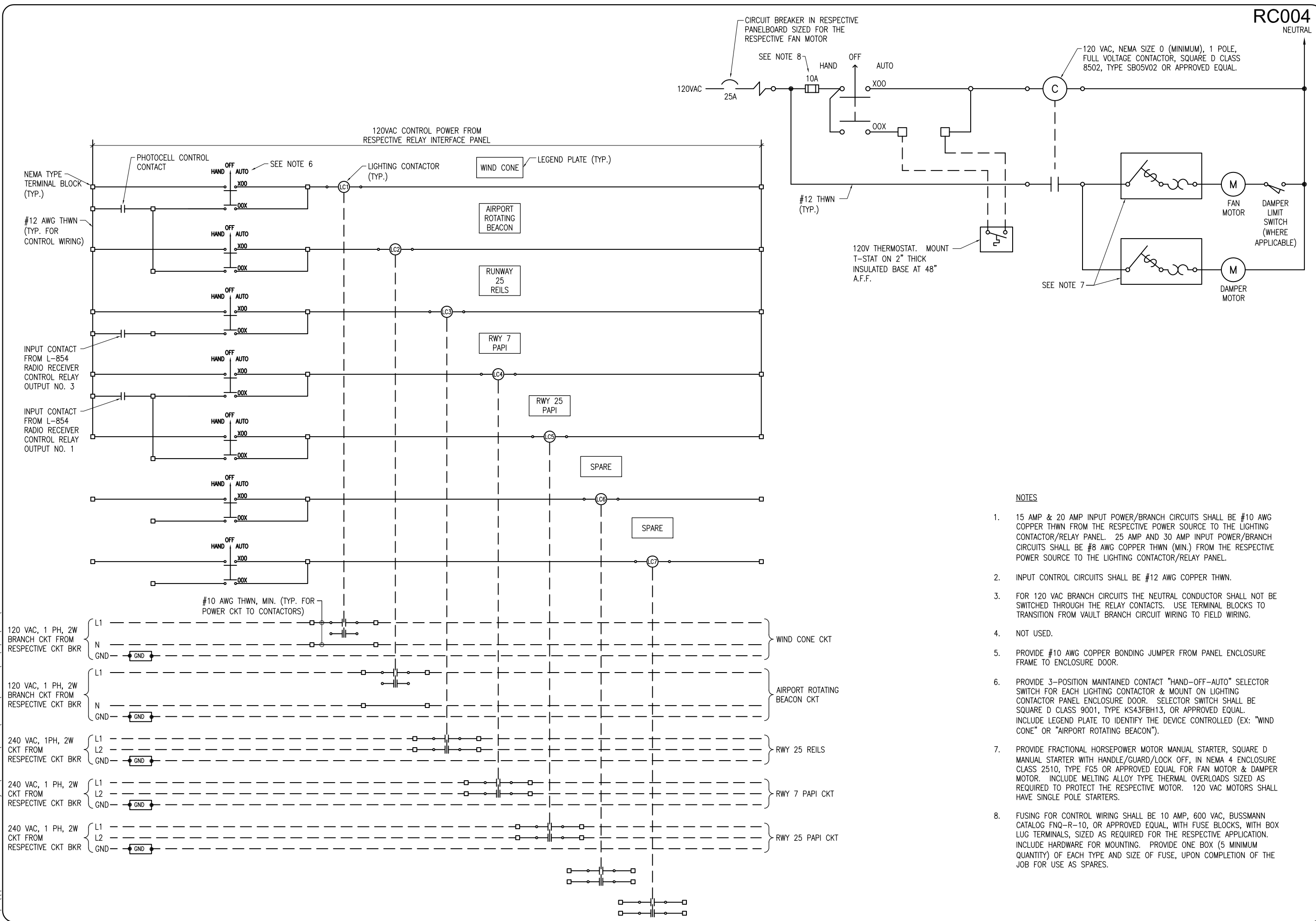

NOTES

- 15 AMP & 20 AMP INPUT POWER/BRANCH CIRCUITS SHALL BE #10 AWG COPPER THWN FROM THE RESPECTIVE POWER SOURCE TO THE LIGHTING CONTACTOR/RELAY PANEL. 25 AMP AND 30 AMP INPUT POWER/BRANCH CIRCUITS SHALL BE #8 AWG COPPER THWN (MIN.) FROM THE RESPECTIVE POWER SOURCE TO THE LIGHTING CONTACTOR/RELAY PANEL.
- INPUT CONTROL CIRCUITS SHALL BE #12 AWG COPPER THWN.
- FOR 120 VAC BRANCH CIRCUITS THE NEUTRAL CONDUCTOR SHALL NOT BE SWITCHED THROUGH THE RELAY CONTACTS. USE TERMINAL BLOCKS TO TRANSITION FROM VAULT BRANCH CIRCUIT WIRING TO FIELD WIRING.
- NOT USED.
- PROVIDE #10 AWG COPPER BONDING JUMPER FROM PANEL ENCLOSURE FRAME TO ENCLOSURE DOOR.
- PROVIDE 3-POSITION MAINTAINED CONTACT "HAND-OFF-AUTO" SELECTOR SWITCH FOR EACH LIGHTING CONTACTOR & MOUNT ON LIGHTING CONTACTOR PANEL ENCLOSURE DOOR. SELECTOR SWITCH SHALL BE SQUARE D CLASS 9001, TYPE KS43FBH13, OR APPROVED EQUAL. INCLUDE LEGEND PLATE TO IDENTIFY THE DEVICE CONTROLLED (EX: "WIND CONE" OR "AIRPORT ROTATING BEACON").
- PROVIDE FRACTIONAL HORSEPOWER MOTOR MANUAL STARTER, SQUARE D MANUAL STARTER WITH HANDLE/GUARD/LOCK OFF, IN NEMA 4 ENCLOSURE CLASS 2510, TYPE FG5 OR APPROVED EQUAL FOR FAN MOTOR & DAMPER MOTOR. INCLUDE MELTING ALLOY TYPE THERMAL OVERLOADS SIZED AS REQUIRED TO PROTECT THE RESPECTIVE MOTOR. 120 VAC MOTORS SHALL HAVE SINGLE POLE STARTERS.
- FUSING FOR CONTROL WIRING SHALL BE 10 AMP, 600 VAC, BUSSMANN CATALOG FNQ-R-10, OR APPROVED EQUAL, WITH FUSE BLOCKS, WITH BOX LUG TERMINALS, SIZED AS REQUIRED FOR THE RESPECTIVE APPLICATION. INCLUDE HARDWARE FOR MOUNTING. PROVIDE ONE BOX (5 MINIMUM QUANTITY) OF EACH TYPE AND SIZE OF FUSE, UPON COMPLETION OF THE JOB FOR USE AS SPARES.

REVISION	
DATE	
ROCHELLE MUNICIPAL AIRPORT MAJOR THOMAS F. KORITZ FIELD ROCHELLE, ILLINOIS	
IL PROJ.: RPJ-4136 A.I.P. PROJ.: 3-17-0087-B14	
Hanson Project No. 10A0139D	File Name E-606-CTL.dwg
Scale AS SHOWN	Date 11/22/11
LAYOUT JFC 10/21/11	REVIEWED CAH/KNL 10/21/11
DRAWN JFC 10/21/11	
© Copyright Hanson Professional Services Inc. 2011 Hanson Professional Services Inc. 1525 South Sixth Street Springfield, Illinois 62703-2886 Ph: (217) 788-2450 Fax: (217) 788-2503 www.hanson-inc.com Offices Nationwide	
CONSTRUCT ELECTRICAL VAULT	VAULT LIGHTING CONTACTOR SCHEMATIC
17 17 of 24 sheets	

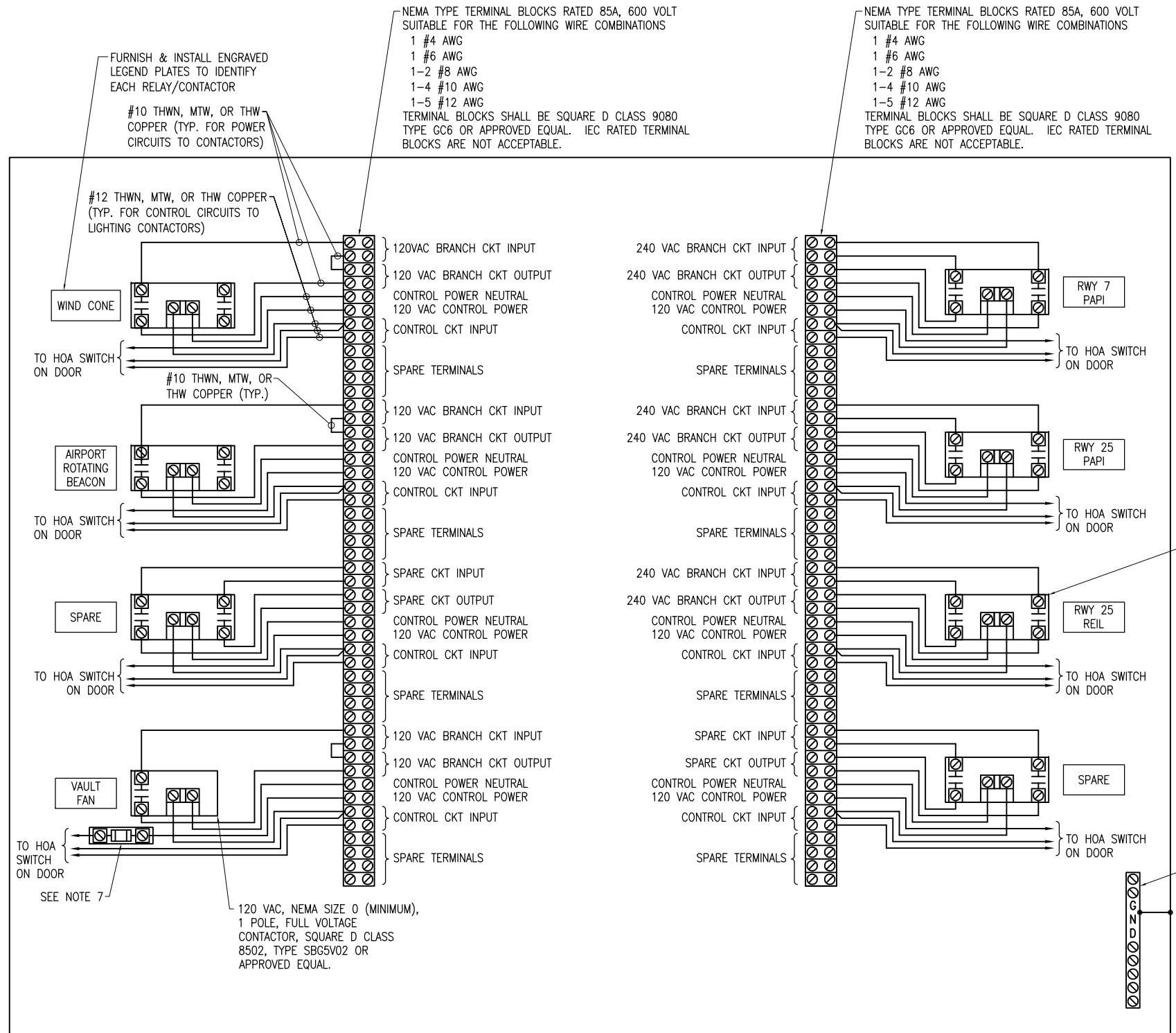

- NOTES**
- 15 AMP & 20 AMP INPUT POWER/BRANCH CIRCUITS SHALL BE #10 AWG COPPER THWN FROM THE RESPECTIVE POWER SOURCE TO THE LIGHTING CONTACTOR PANEL. 30 AMP INPUT POWER/BRANCH CIRCUITS SHALL BE #8 AWG COPPER THWN (MIN.) FROM THE RESPECTIVE POWER SOURCE TO THE LIGHTING CONTACTOR PANEL.
 - INPUT CONTROL CIRCUITS SHALL BE #12 AWG COPPER THWN.
 - FOR 120 VAC BRANCH CIRCUITS THE NEUTRAL CONDUCTOR SHALL NOT BE SWITCHED THROUGH THE RELAY CONTACTS. USE TERMINAL BLOCKS TO TRANSITION FROM VAULT BRANCH CIRCUIT WIRING TO FIELD WIRING.
 - PROVIDE #10 AWG COPPER BONDING JUMPER FROM PANEL ENCLOSURE FRAME TO ENCLOSURE DOOR.
 - PROVIDE 3-POSITION MAINTAINED CONTACT "HAND-OFF-AUTO" SELECTOR SWITCH FOR EACH LIGHTING CONTACTOR & MOUNT ON LIGHTING CONTACTOR PANEL ENCLOSURE DOOR. SELECTOR SWITCH SHALL BE SQUARE D CLASS 9001, TYPE KS43FBH13, OR APPROVED EQUAL. INCLUDE LEGEND PLATE TO IDENTIFY THE DEVICE CONTROLLED (EX: "WIND CONE" OR "AIRPORT ROTATING BEACON").
 - SEE "LIGHTING CONTACTOR SCHEMATIC" AND "EXHAUST FAN CONTROL SCHEMATIC" FOR ADDITIONAL INFORMATION ON WIRING. ALSO SEE "AIRFIELD LIGHTING CONTROL WIRING SCHEMATIC" AND "L-821 PANEL CONTROL WIRING SCHEMATIC". COORDINATE WIRING WITH L-821 PANEL MANUFACTURER.
 - FUSING FOR FAN CIRCUIT CONTROL WIRING SHALL BE 10 AMP, 600 VAC, BUSSMANN CATALOG FNQ-R-10, OR APPROVED EQUAL, WITH FUSE BLOCKS, WITH BOX LUG TERMINALS, SIZED AS REQUIRED FOR THE RESPECTIVE APPLICATION. INCLUDE HARDWARE FOR MOUNTING. PROVIDE ONE BOX (5 MINIMUM QUANTITY) OF EACH TYPE AND SIZE OF FUSE, UPON COMPLETION OF THE JOB FOR USE AS SPARES.
 - INCLUDE LEGEND PLATE LABELED "NOTICE: CONTACTORS HAVE REMOTE LOCATED CONTROLS AND MAY ACTIVATE AT ANY TIME".
 - 120/240 VAC PHASE "A" CONDUCTORS SHALL HAVE BLACK COLORED INSULATION. 120/240 VAC PHASE "B" CONDUCTORS SHALL HAVE RED COLORED INSULATION. NEUTRAL CONDUCTORS SHALL HAVE WHITE COLORED INSULATION. INSULATED EQUIPMENT GROUND WIRES SHALL HAVE GREEN COLORED INSULATION.
 - CONTROL PANEL FOR AIRFIELD NAVAIDS & VAULT FAN SHALL BE MANUFACTURED BY A UL 508 INDUSTRIAL CONTROL PANEL BUILDER OR AN FAA APPROVED L-821 PANEL BUILDER, AND SHALL BE MANUFACTURED IN THE UNITED STATES TO COMPLY WITH THE AIRPORT IMPROVEMENT PROGRAM BUY AMERICAN REQUIREMENT AND THE "BUY AMERICAN ACT". GUS BERTHOLD ELECTRIC (1900 WEST CARROLL AVENUE, CHICAGO, IL 60612, PHONE: 312-243-5767) IS AN APPROVED UL 508 INDUSTRIAL CONTROL PANEL BUILDER.

NOV 23, 2011 12:37 PM WALL00723
 p:\s\spj-svr306.hanson.com\Projects\Documents\10401390\10401390\CAD\Airport\Sheet\E-604-CTL

CONTROL PANEL FOR AIRFIELD NAVAIDS AND VAULT FAN

NEMA 12 ENCLOSURE WITH HINGED DOOR SIZED AS REQUIRED TO HOUSE LIGHTING CONTACTORS, TERMINAL BLOCKS, WIRING & INTERFACE TO EXISTING CONDUITS, MINIMUM 36"Hx24"Wx8"D AS MANUFACTURED BY HOFFMAN OR APPROVED EQUAL.

REVISION					
DATE					
ROCHELLE MUNICIPAL AIRPORT MAJOR THOMAS F. KORITZ FIELD ROCHELLE, ILLINOIS					
IL PROJ.: RPJ-4136 A.I.P. PROJ.: 3-17-0087-B14					
Hanson Project No. 10401390 Filename E-604-CTL.dwg Scale AS SHOWN Date 11/22/11		LAYOUT JFC 10/21/11 DRAWN JFC 10/21/11 REVIEWED CAH/KNL 10/21/11		© Copyright Hanson Professional Services Inc. 2011 Hanson Professional Services Inc. 1525 South Sixth Street Springfield, Illinois 62703-2886 Ph: (217) 788-2450 Fax: (217) 788-2503 www.hanson-inc.com Offices Nationwide	
CONSTRUCT ELECTRICAL VAULT			LIGHTING CONTACTOR PANEL DETAIL		
18 18 of 24 sheets					

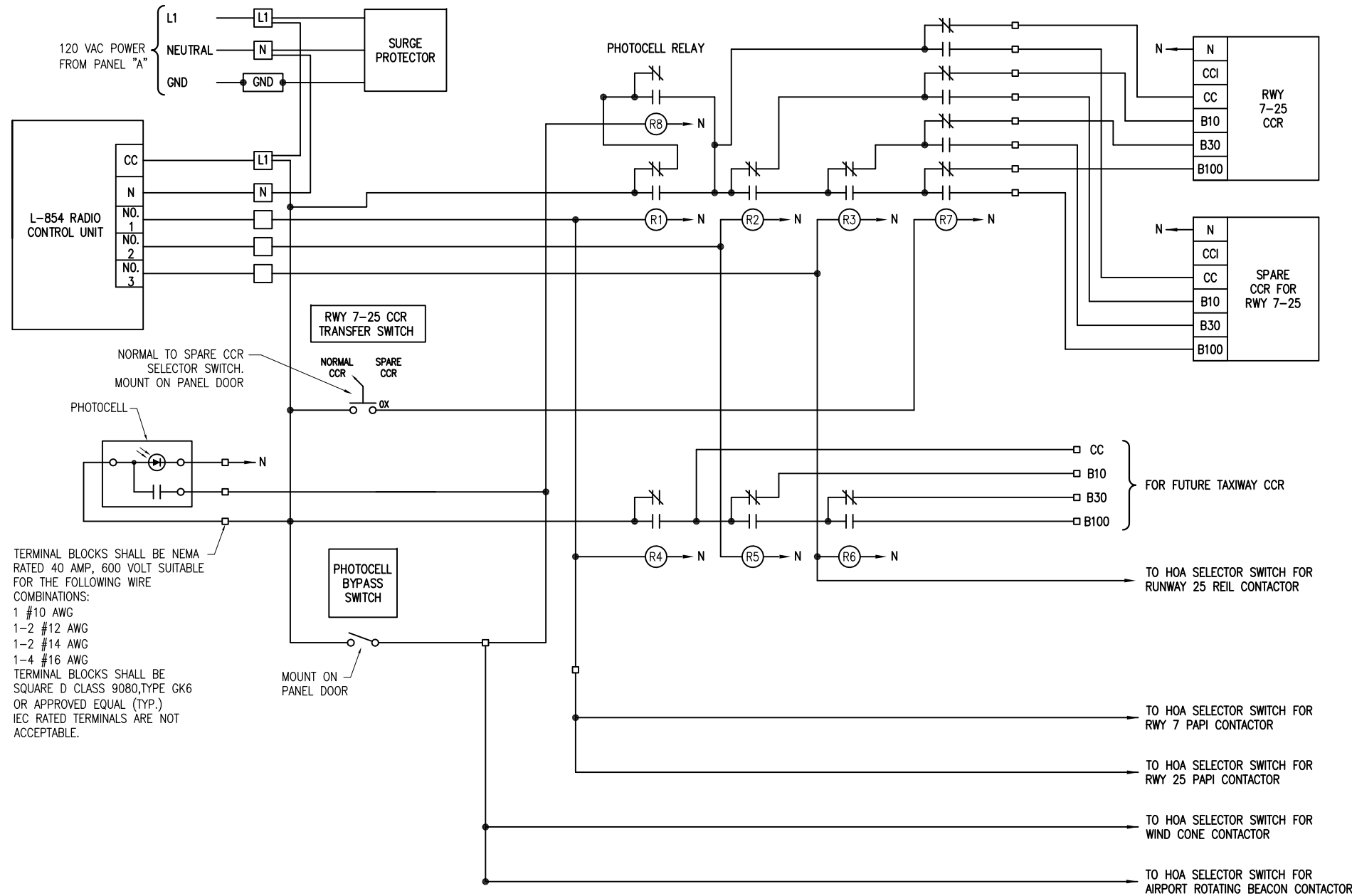

TERMINAL BLOCKS SHALL BE NEMA RATED 40 AMP, 600 VOLT SUITABLE FOR THE FOLLOWING WIRE COMBINATIONS:
 1 #10 AWG
 1-2 #12 AWG
 1-2 #14 AWG
 1-4 #16 AWG
 TERMINAL BLOCKS SHALL BE SQUARE D CLASS 9080, TYPE GK6 OR APPROVED EQUAL (TYP.)
 IEC RATED TERMINALS ARE NOT ACCEPTABLE.

AIRFIELD LIGHTING CONTROL WIRING SCHEMATIC

- NOTES:**
- RELAY INTERFACE CONTROL PANEL SHALL BE MANUFACTURED BY AN FAA APPROVED L-821 PANEL BUILDER OR A UL 508 INDUSTRIAL CONTROL PANEL BUILDER, AND SHALL BE MANUFACTURED IN THE UNITED STATES TO COMPLY WITH THE AIRPORT IMPROVEMENT PROGRAM BUY AMERICAN REQUIREMENT AND THE "BUY AMERICAN ACT".
 - PANEL SHALL BE IN A NEMA 12 ENCLOSURE WITH HINGED COVER. DRILL HOLE IN BOTTOM OF ENCLOSURE TO ALLOW CONDENSATION TO ESCAPE.
 - EXTERNAL CONTROL CABLE SHALL BE NO. 12 AWG COPPER, 600 VOLT CABLE. ALL PANEL INTERIOR CONTROL CABLE SHALL BE MINIMUM 16 AWG, COPPER, 600 VOLT CABLE.
 - IN THE AUTOMATIC MODE OF OPERATION THE RUNWAY/TAXIWAY CIRCUIT WILL BE CONTROLLED BY THE PHOTOCELL & THE L-854 RADIO CONTROL UNIT IN THE FOLLOWING MANNER:
 PHOTOCELL -10% BRIGHTNESS
 3 CLICKS -10% BRIGHTNESS
 5 CLICKS -30% BRIGHTNESS
 7 CLICKS -100% BRIGHTNESS
 - IN THE AUTOMATIC MODE OF OPERATION THE WIND CONE & AIRPORT ROTATING BEACON SHALL BE ACTIVATED BY THE PHOTOCELL OR PHOTOCELL BYPASS SWITCH.
 - IN THE AUTOMATIC MODE OF OPERATION THE RWY 7-25 PAPI'S WILL BE CONTROLLED BY THE L-854 RADIO CONTROL UNIT IN THE FOLLOWING MANNER:
 3 CLICKS - ON
 5 CLICKS - REMAIN ON
 7 CLICKS - REMAIN ON.
 - IN THE AUTOMATIC MODE OF OPERATION THE RUNWAY 25 REILS WILL BE CONTROLLED BY THE L-854 RADIO CONTROL UNIT IN THE FOLLOWING MANNER:
 3 CLICKS -OFF
 5 CLICKS -OFF
 7 CLICKS -ON
 - EQUIPMENT GROUND WIRES SHALL BE INCLUDED WITH EACH BRANCH CIRCUIT & EACH CONTROL CIRCUIT.
 - INCLUDE PHOTOCELL BYPASS SWITCH.
 - SURGE PROTECTOR SHALL BE UL LISTED PER UL 1449, SUITABLE FOR 120 VAC, 1PH, 2 WIRE PLUS GROUND SYSTEM WITH SURGE CURRENT RATING OF 40 KA (MIN.), 8x20 MICROSECOND WAVE, AND STATUS INDICATION LIGHTS IN A WEATHERPROOF HOUSING, JOSLYN MODEL 1260-21, OR APPROVED EQUAL. MAINTAIN LEADS AS SHORT & AS STRAIGHT AS POSSIBLE. INCLUDE MOUNTING BRACKET.
 - INCLUDE EQUIPMENT GROUND BAR, ILSCO D167-12 OR EQUAL.
 - CONTROL RELAYS SHALL HAVE 10 AMP CONTACT RATINGS AT 240 VAC WITH 120 VAC COILS. PROVIDE 3 SPARE RELAYS FOR EACH TYPE USED IN THE RELAY INTERFACE PANEL.
 - COLOR CODING FOR THE CONTROL WIRING TO EACH CONSTANT CURRENT REGULATOR SHALL BE CONSISTENT FOR ALL REGULATORS. COLOR CODING SHALL BE AS FOLLOWS:
 CC -RED
 10% -ORANGE
 30% -YELLOW
 100% -BLUE
 NEUTRAL -WHITE
 EQUIPT. GND -GREEN
 ALSO TAG THE CONTROL WIRES WITH THE RESPECTIVE DESIGNATION (CC, 10%, 30%, 100%)
 - "N" DESIGNATES NEUTRAL CONNECTION OR NEUTRAL CONDUCTOR.
 - TERMINAL BLOCKS SHALL BE NEMA RATED TYPE TERMINALS, IEC RATED TERMINAL BLOCKS ARE NOT ACCEPTABLE.

NOV 23, 2011 12:38 PM WALLE0723
 p:\s\spi-svr306.hanson.com\Projects\Documents\10401390\10401390\10401390\CAD\Airport\Sheet\E-605-CTL

REVISION					
DATE					
ROACHELLE MUNICIPAL AIRPORT MAJOR THOMAS F. KORITZ FIELD ROCHELLE, ILLINOIS					
IL. PROJ.: RPJ-4136 AL.P. PROJ.: 3-17-0087-B14					
Hanson Project No.	10401390	LAYOUT	JFC	10/21/11	
Filename	E-605-CTL.dwg	DRAWN	JFC	10/21/11	
Scale	AS SHOWN	REVIEWED	CAH/KNL	10/21/11	
Date	11/22/11	© Copyright Hanson Professional Services Inc. 2011 Hanson Professional Services Inc. 1525 South Sixth Street Springfield, Illinois 62703-2886 Ph: (217) 788-2450 Fax: (217) 788-2503 www.hanson-inc.com Offices Nationwide			
CONSTRUCT ELECTRICAL VAULT			AIRFIELD LIGHTING CONTROL WIRING SCHEMATIC		
19					
19 of 24 sheets					

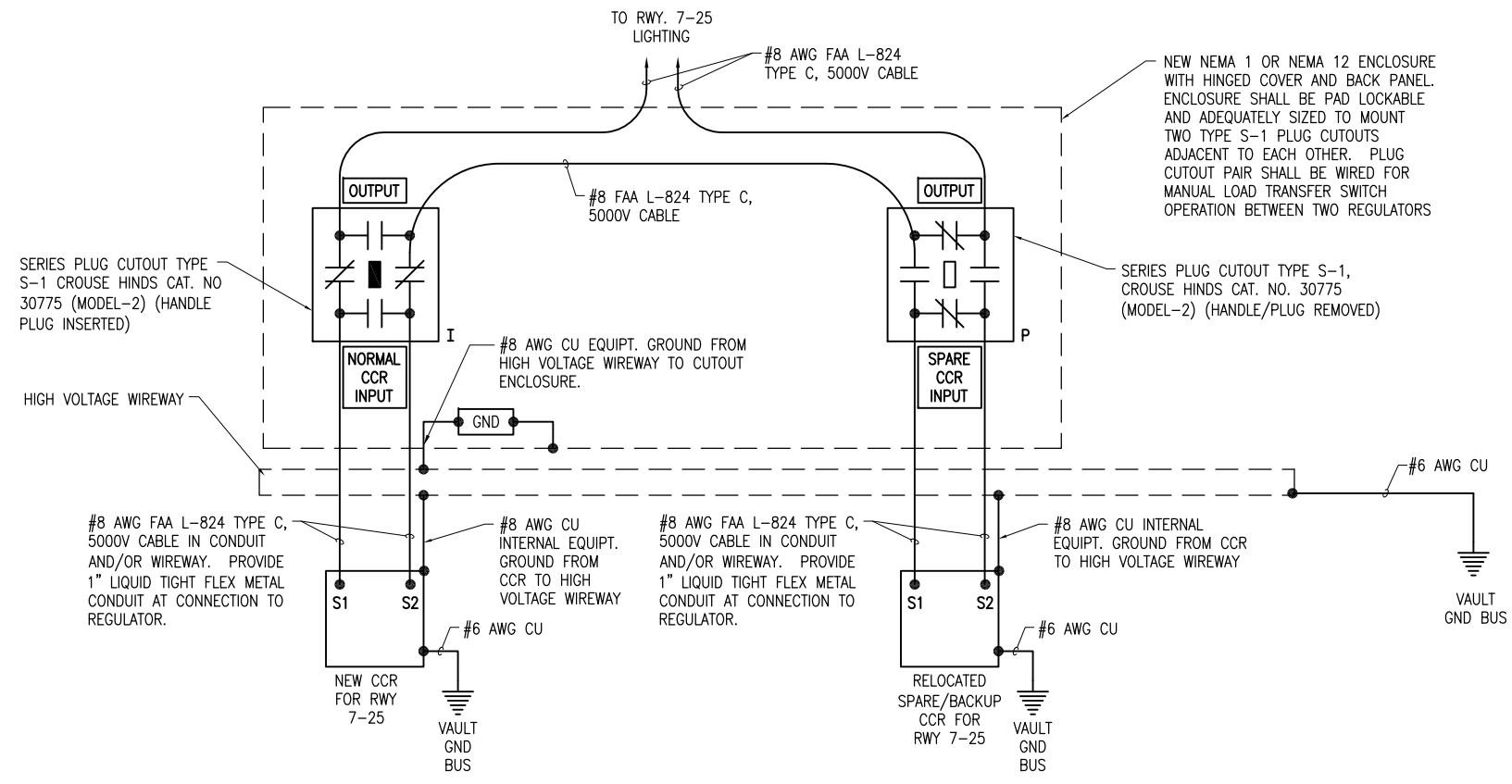

HIGH VOLTAGE WIRING SCHEMATIC FOR RUNWAY

NOT TO SCALE

NOTES

1. PROVIDE PHENOLIC ENGRAVED LEGEND PLATES FOR EACH CONSTANT CURRENT REGULATOR (EXISTING & NEW) NOTING THE RUNWAY AND/OR TAXIWAY SERVED.
2. EACH PLUG CUTOUT CABINET SHALL BE FURNISHED WITH A PHENOLIC ENGRAVED LEGEND PLATE THAT IDENTIFIES THE RESPECTIVE RUNWAY OR TAXIWAY CIRCUIT OR REGULATOR. INCLUDE AN ADDITIONAL LEGEND PLATE LABELED "CAUTION OPERATE CUTOUTS WITH CCR SHUT OFF".
3. PROVIDE PHENOLIC ENGRAVED LEGEND PLATES FOR THE CUTOUTS TO IDENTIFY THE RESPECTIVE REGULATOR OUTPUT CONNECTION AND THE RESPECTIVE CIRCUIT LOAD CONNECTION.
4. BOND EACH REGULATOR FRAME TO VAULT GROUND BUS WITH A DEDICATED #6 AWG COPPER BONDING JUMPER.
5. PROVIDE ADEQUATE WORKING SPACE IN FRONT OF EACH CUTOUT ENCLOSURE TO MEET NEC CLEARANCE REQUIREMENTS.
6. LIQUID TIGHT FLEXIBLE METAL CONDUIT AND ASSOCIATED FITTINGS SHALL BE U.L. LISTED TO MEET THE REQUIREMENTS OF NEC 350.6, SUITABLE FOR GROUNDING AND SUNLIGHT RESISTANT. LIQUID TIGHT FLEXIBLE METAL CONDUIT THAT IS USED FOR FLEXIBILITY (INCLUDING CONNECTIONS TO CCR'S & TRANSFORMERS) SHALL REQUIRE AN EXTERNAL BONDING JUMPER OR INTERNAL EQUIPMENT GROUNDING CONDUCTOR PER NEC 350.60. EXTERNAL BONDING JUMPERS USED WITH CCR INSTALLATIONS SHALL BE #6 AWG COPPER (MINIMUM). DO NOT INSTALL LIQUID TIGHT FLEXIBLE METAL CONDUIT THAT IS NOT UL LISTED. CONFIRM LIQUID TIGHT FLEXIBLE METAL CONDUIT BEARS THE UL LABEL PRIOR TO INSTALLING IT.
7. SERIES PLUG CUTOUTS SHALL BE RATED SUITABLE FOR NORMAL OPERATION WITH HANDLE REMOVED OR HANDLE INSERTED. SERIES PLUG CUTOUTS SHALL BE CROUSE-HINDS CAT. NO. 30775, OR APPROVED EQUAL. THE RESPECTIVE MANUFACTURER SHALL CERTIFY IN WRITING THAT THEIR CUTOUT IS SUITABLE AND RATED FOR THE RESPECTIVE APPLICATION. OTHER CUTOUTS THAT DO NOT FUNCTION THE SAME AS CROUSE-HINDS CAT. NO. 30775 (MODEL-2) ARE NOT ACCEPTABLE.
8. HIGH VOLTAGE & LOW VOLTAGE CIRCUITS SHALL NOT BE INSTALLED IN THE SAME WIREWAY, CONDUIT, HANDHOLE, JUNCTION BOX, OR RACEWAY.

LEGEND

- "I" DENOTES PLUG CUTOUT WITH PLUG INSERTED
- "P" DENOTES PLUG CUTOUT WITH PLUG PULLED
- "CCR" DENOTES CONSTANT CURRENT REGULATOR

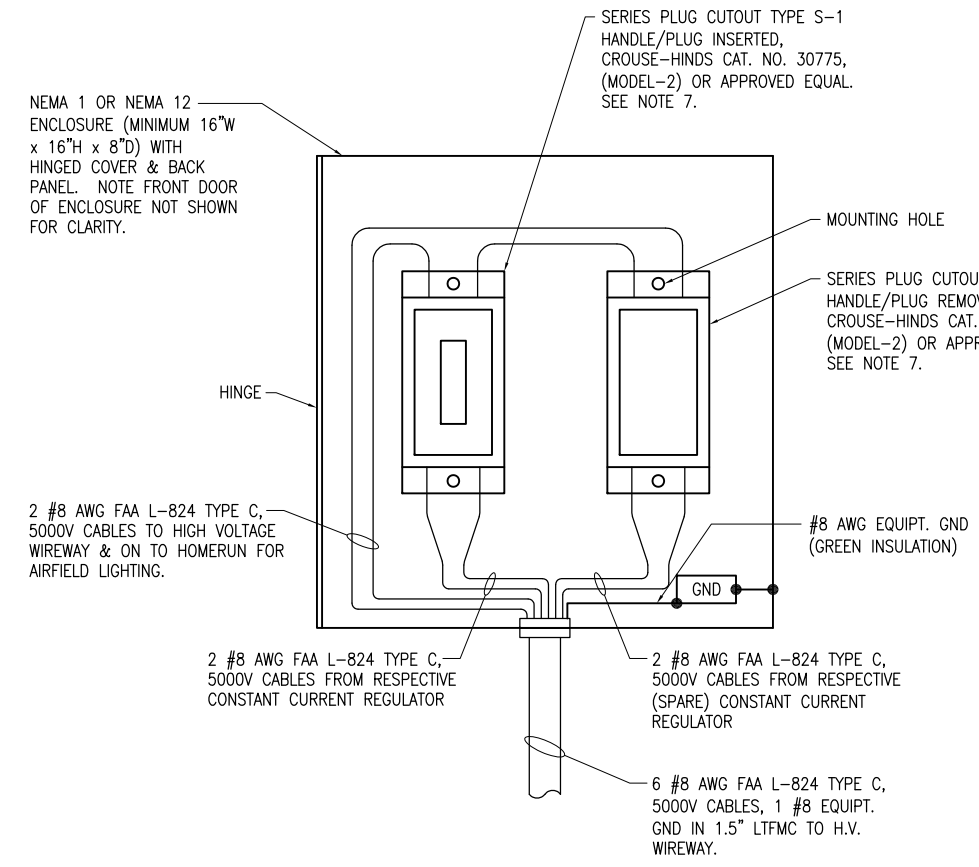

SERIES PLUG CUTOUT MOUNTING DETAIL FOR RUNWAY CIRCUIT

NOT TO SCALE

NOV 23, 2011 12:39 PM WALLE00723
 p:\s\sp\svr306.hanson.com\Projects\Documents\1040139\1040139D\CAD\Airport\Sheet\E-611-WRC

REVISION	DATE

ROCHELLE MUNICIPAL AIRPORT
 MAJOR THOMAS F. KORITZ FIELD
 ROCHELLE, ILLINOIS

IL PROJ.: RPJ-4136 A.I.P. PROJ.: 3-17-0087-B14

Hanson Project No. 1040139D	File Name E-611-WRC.dwg	Scale AS SHOWN	Date 11/22/11
LAYOUT	JFC	10/21/11	
DRAWN	JFC	10/21/11	
REVIEWED	CAH/KNL	10/21/11	

HANSON
 © Copyright Hanson Professional Services Inc. 2011
 Hanson Professional Services Inc.
 1525 South Sixth Street
 Springfield, Illinois 62703-2886
 Ph: (217) 788-2450 Fax: (217) 788-2503
 www.hanson-inc.com
 Offices Nationwide

CONSTRUCT ELECTRICAL VAULT
HIGH VOLTAGE WIRING SCHEMATIC FOR RUNWAY

LEGEND PLATE SCHEDULE	
DEVICE	LABEL
SERVICE BREAKER	SERVICE BREAKER 240 VAC, 400 AMPS, 1 PH, 3W
SERVICE BREAKER	WARNING SHOCK HAZARD EXISTS IF GROUNDING ELECTRODE CONDUCTOR OR BONDING JUMPER CONNECTION IN THIS EQUIPMENT IS REMOVED WHILE ALTERNATE SOURCE(S) IS ENERGIZED.
VAULT MAIN DISTRIBUTION PANELBOARD "A"	MAIN DISTRIBUTION PANEL "A" 120/240 VAC, 1 PH, 3W
MAIN BREAKER IN VAULT MAIN DISTRIBUTION PANEL A	MAIN BREAKER
PORTABLE GENERATOR QUICK CONNECT. SEE NOTE 1.	NOTE PORTABLE GENERATOR NEUTRAL IS BONDED TO GROUND AT THE SERVICE DISCONNECT
AUTOMATIC TRANSFER SWITCH SEE NOTE 1	AUTOMATIC TRANSFER SWITCH 120/240 VAC, 400 AMPS
RUNWAY 7-25 CCR	RUNWAY 7-25
SPARE RUNWAY 7-25 CCR	SPARE FOR RUNWAY 7-25
CUTOUT ENCLOSURE FOR RUNWAY 7-25	RUNWAY 7-25 CUTOUTS
CUTOUT ENCLOSURE	CAUTION OPERATE CUTOUTS WITH CCR SHUT OFF
NORMAL CUTOUT INPUT SIDE CONNECTION FOR RUNWAY 7-25	NORMAL CCR INPUT
SPARE CUTOUT INPUT SIDE CONNECTION FOR RUNWAY 7-25	SPARE CCR INPUT
EACH CUTOUT OUTPUT SIDE CONNECTION (2 LEGEND PLATES)	OUTPUT

NOTE 1: LEGEND PLATES ASSOCIATED WITH SERVICE TRANSFER SWITCH AND PORTABLE GENERATOR CONNECTION SHALL ONLY BE INCLUDED WITH ADDITIVE ALTERNATE BID.

LEGEND PLATE SCHEDULE CONTINUED	
DEVICE	LABEL
RADIO RELAY INTERFACE PANEL	RADIO RELAY INTERFACE PANEL
MANUAL TRANSFER SWITCH FOR RUNWAY 7-25 NORMAL CCR AND SPARE/BACKUP CCR	TRANSFER SWITCH FOR RUNWAY 7-25 CONSTANT CURRENT REGULATORS
MANUAL TRANSFER SWITCH FOR RUNWAY 7-25 NORMAL CCR AND SPARE/BACKUP CCR - NORMAL SWITCH POSITION	NORMAL CCR
MANUAL TRANSFER SWITCH FOR RUNWAY 7-25 NORMAL CCR AND SPARE/BACKUP CCR - BACKUP SWITCH POSITION	SPARE/BACKUP CCR
CONTROL PANEL FOR AIRFIELD NAVAIDS AND VAULT FAN	CONTACTOR PANEL FOR AIRFIELD NAVAIDS & VAULT FAN
CONTACTOR PANEL FOR AIRFIELD NAVAIDS AND VAULT FAN	NOTICE CONTACTORS HAVE REMOTE LOCATED CONTROLS AND MAY ACTIVATE AT ANY TIME
LOW VOLTAGE WIREWAY (PROVIDE 4 LEGEND PLATES 1/2" HIGH BLACK LETTERS WHITE BACKGROUND)	LOW VOLTAGE
HIGH VOLTAGE WIREWAY (PROVIDE 4 LEGEND PLATES 1/2" HIGH BLACK LETTERS WHITE BACKGROUND)	HIGH VOLTAGE
VAULT GROUND BUS (PROVIDE 4 LEGEND PLATES 1/2" HIGH WHITE LETTERS GREEN BACKGROUND; INSTALL ABOVE OR BELOW GROUND BUS)	VAULT GROUND BUS
GROUNDING ELECTRODE CONDUCTORS TERMINATED ON VAULT GROUND BUS. (PROVIDE 3 LEGEND PLATES & SECURE TO CONDUCTORS WITH NYLON STRING OR CABLE TIES)	DO NOT DISCONNECT

NOTE: LEGEND PLATES SHALL BE WEATHERPROOF ENGRAVED PLASTIC OR PHENOLIC MATERIAL, 1/4" HIGH BLACK LETTERS ON A WHITE BACKGROUND UNLESS NOTED OTHERWISE. SECURE WITH WEATHERPROOF ADHESIVE AND MACHINE SCREWS. FURNISH ADDITIONAL LEGEND PLATES WHERE REQUIRED BY CODE, FOR ADDITIONAL EQUIPMENT, AS DETAILED HEREIN ON THE PLANS, AND AS NOTED IN THE SPECIAL PROVISION SPECIFICATIONS.

FURNISH & INSTALL A WEATHERPROOF WARNING LABEL FOR EACH SAFETY SWITCH, PANELBOARD, LOAD CENTER, CUTOUT, & CONTROL PANEL TO WARN PERSONS OF POTENTIAL ELECTRIC ARC FLASH HAZARDS, PER THE REQUIREMENTS OF NEC 110.16 "FLASH PROTECTION". LABELS SHALL BE HAZARD COMMUNICATION SYSTEMS, LLC (190 OLD MILFORD RD., BOX 1174, MILFORD, PA 18337, PHONE: 1-877-748-0244) PART NO. H6010-9VWHBJ OR APPROVED EQUAL.

- DIRECTIONS TO TRANSFER RUNWAY 7-25 LIGHTING FROM NORMAL CCR TO SPARE/BACKUP CCR.
1. SHUT OFF INPUT POWER (CIRCUIT BREAKER) TO BOTH RWY 7-25 CCR'S & TURN CCR SELECTOR SWITCHES TO OFF.
 2. OPERATE MANUAL TRANSFER SWITCH FOR RWY 7-25 AND MOVE HANDLE FROM "NORMAL" POSITION TO "SPARE/BACKUP" POSITION.
 3. PULL CUTOUT HANDLE FROM NORMAL CCR UNIT & INSERT INTO SPARE CCR CUTOUT.
 4. GO TO RADIO RELAY INTERFACE PANEL & TURN "RWY 7-25 CCR TRANSFER" SELECTOR SWITCH FROM "NORMAL" TO "SPARE" POSITION.
 5. TURN ON INPUT POWER (CIRCUIT BREAKER) TO SPARE RWY 7-25 CCR.
 6. TURN SELECTOR SWITCH ON SPARE CCR TO "REMOTE" POSITION.

PROVIDE PLACARD OR LEGEND PLATE FOR RUNWAY CONSTANT CURRENT REGULATOR PAIR AS NOTED ABOVE: LETTERING TO BE MIN. 1/4" HIGH, BLACK ON WHITE BACKGROUND. LOCATE PLACARD ABOVE OR ADJACENT TO RESPECTIVE CUTOUT ENCLOSURE FOR RUNWAY.

CCR TRANSFER PROCEDURE PLACARD DETAIL

NOT TO SCALE



"DANGER - HIGH VOLTAGE KEEP OUT" SIGN

PROVIDE WARNING SIGN ON VAULT EXTERIOR DOORS LABELED "DANGER - HIGH VOLTAGE - KEEP OUT" PER THE REQUIREMENTS OF NEC 110.34 (C). PROVIDE MINIMUM OF 2 SIGNS (ONE ON EACH DOOR TO THE VAULT).



"DANGER - HIGH VOLTAGE" SIGN

FURNISH AND INSTALL "DANGER - HIGH VOLTAGE" LABELS/SIGNS FOR EACH CUTOUT ENCLOSURE, EACH CONSTANT CURRENT REGULATOR, AND THE HIGH VOLTAGE WIREWAY, TO COMPLY WITH FAA AC 150/5340-26B "MAINTENANCE OF AIRPORT VISUAL AID FACILITIES".

REVISION		DATE	
ROCHELLE MUNICIPAL AIRPORT MAJOR THOMAS F. KORITZ FIELD ROCHELLE, ILLINOIS			
IL. PROJ.: RPJ-4136		A.I.P. PROJ.: 3-17-0087-B14	
Hanson Project No. 10A0139D E-610-LGD.dwg AS SHOWN 11/22/11	LAYOUT JFC 10/21/11 DRAWN JFC 10/21/11 REVIEWED CAH/KNL 10/21/11	HANSON © Copyright Hanson Professional Services Inc. 2011 Hanson Professional Services Inc. 1525 South Sixth Street Springfield, Illinois 62703-2886 Ph: (217) 788-2450 Fax: (217) 788-2503 www.hanson-inc.com Offices Nationwide	
CONSTRUCT ELECTRICAL VAULT		LEGEND PLATE SCHEDULES	
21 21 of 24 sheets			

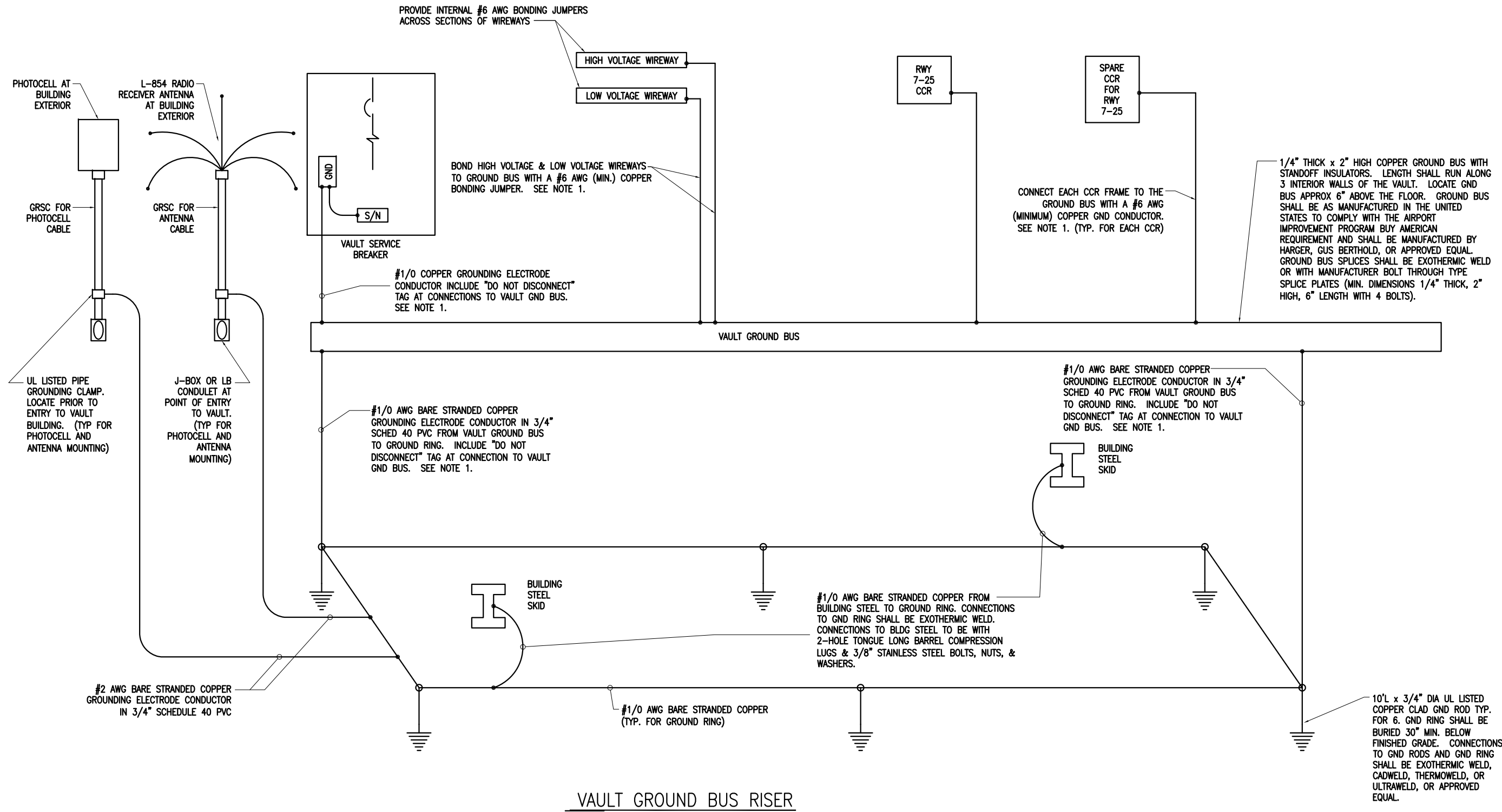

VAULT GROUND BUS RISER

- NOTES**
1. CONNECTIONS TO GROUND BUS BAR SHALL BE WITH 2-HOLE TONGUE LONG BARREL COMPRESSION LUGS BOLTED TO THE BUS BAR.
 2. ALL CONNECTIONS TO THE GROUND RING AND GROUND RODS SHALL BE EXOTHERMIC WELD.
 3. ALL INSULATED GROUND WIRES SHALL HAVE GREEN COLORED INSULATION FOR ALL CONDUCTOR AWG AND KCMIL.
 4. ALL WORK SHOWN ON THIS SHEET SHALL BE PAID FOR UNDER ITEM AR109200 "INSTALL ELECTRICAL EQUIPMENT" PER LUMP SUM.
 5. TEST GROUND RING AND RECORD RESULTS. WHERE GROUND RESISTANCE TEST RESULTS EXCEED 10 OHMS CONTACT PROJECT ENGINEER FOR FURTHER DIRECTION.

REVISION	DATE

ROCHELLE MUNICIPAL AIRPORT
 MAJOR THOMAS F. KORITZ FIELD
 ROCHELLE, ILLINOIS

IL PROJ.: RPJ-4136 A.I.P. PROJ.: 3-17-0087-B14

Hanson Project No. 10A0139D	File Name E-608-GND.dwg	Scale AS SHOWN	Date 11/22/11
LAYOUT	JFC	10/21/11	
DRAWN	JFC	10/21/11	
REVIEWED	CAH/KNL	10/21/11	

HANSON
 © Copyright Hanson Professional Services Inc. 2011
 Hanson Professional Services Inc.
 1525 South Sixth Street
 Springfield, Illinois 62703-2886
 Ph: (217) 788-2450 Fax: (217) 788-2503
 www.hanson-inc.com
 Offices Nationwide

CONSTRUCT
 ELECTRICAL VAULT

VAULT GROUND BUS RISER

NOV 23, 2011 12:41 PM WALLE00723
 p:\s\svr306.hanson.com\Projects\Documents\10A0139D\10A0139D\CAD\Airport\Sheet\E-608-GND

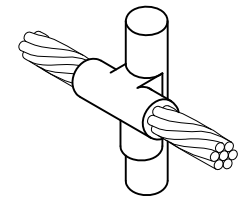

CABLE TO GROUND ROD

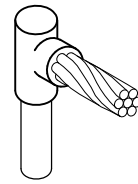

CABLE TO GROUND ROD

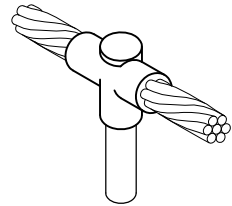

CABLE TO GROUND ROD

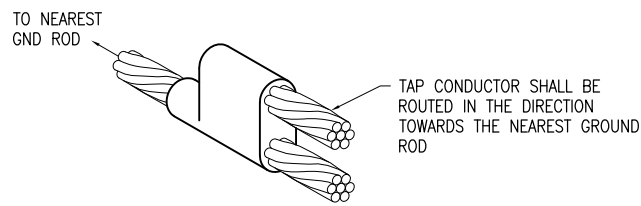

CABLE TO CABLE HORIZONTAL PARALLEL TAP

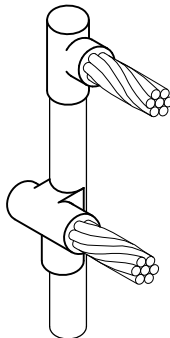

CABLES TO GROUND ROD

DETAIL NOTES

1. ALL BELOW GRADE CONNECTIONS TO GROUND RODS & GROUND RING CONDUCTORS SHALL BE EXOTHERMIC WELD TYPE CONNECTIONS. EXOTHERMIC WELDS SHALL BE CADWELD AS MANUFACTURED BY ERICO PRODUCTS, SOLON, OHIO, ULTRAWELD AS MANUFACTURED BY HARGER LIGHTNING PROTECTION & GROUNDING EQUIPMENT, GRAYSLAKE, IL, OR THERMOWELD AS MANUFACTURED BY CONTINENTAL INDUSTRIES, TULSA, OKLAHOMA. VERIFY PROPER SIZES, MOLDS, TYPES, AND REQUIREMENTS FOR THE RESPECTIVE APPLICATION WITH THE MANUFACTURER, AND INSTALL PER THEIR DIRECTIONS.
2. FOR APPLICATIONS TO GALVANIZED STEEL OR PAINTED STEEL, REMOVE GALVANIZING AND/OR PAINT & CLEAN THE SURFACE TO EXPOSE BARE STEEL BEFORE MAKING EXOTHERMIC WELD CONNECTION.
3. INDIVIDUAL GROUNDING ELECTRODE CONDUCTORS SHALL NOT BE INSTALLED IN METAL CONDUIT. INSTALL GROUNDING ELECTRODE CONDUCTORS IN SCHED 40 PVC CONDUIT AS REQUIRED IN FOUNDATIONS, FOR PROTECTION, WHERE ENTERING ENCLOSURES, ETC. WHERE PLASTIC CONDUIT IS USED FOR INDIVIDUAL GROUND WIRES, DO NOT COMPLETELY ENCIRCLE THE CONDUIT WITH FERROUS AND/OR MAGNETIC MATERIALS. WHERE METAL CLAMPS ARE INSTALLED USE NYLON BOLTS, NUTS, WASHERS, & SPACERS TO INTERRUPT A COMPLETE METALLIC PATH FROM ENCIRCLING THE CONDUIT.

EXOTHERMIC WELD DETAILS

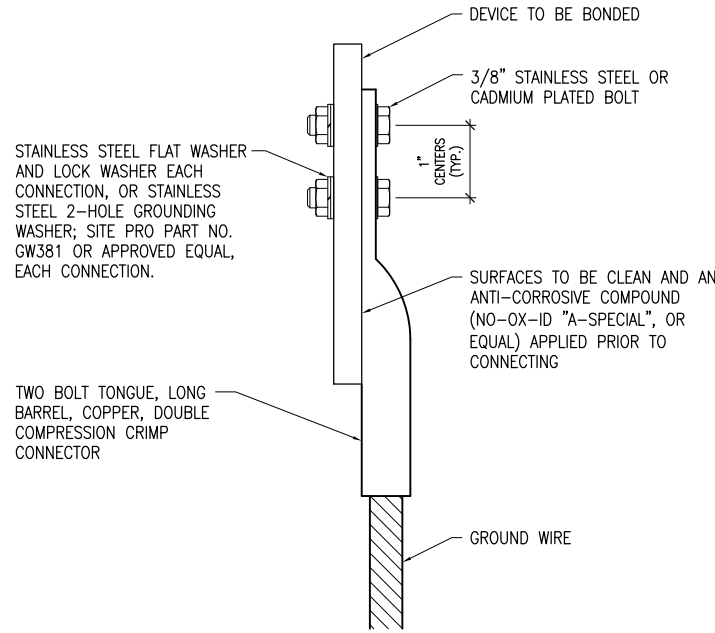

2 HOLE LONG BARREL COMPRESSION LUG TABLE			
WIRE SIZE	BURNDY CAT. NO.	THOMAS & BETTS CAT. NO.	PENN-UNION CAT. NO.
#8 AWG STRANDED	YA8C-2TC38	256-30695-1157	BBLU-8D-2TC38
#6 AWG SOLID	YA8C-2TC38 OR YGA6C-2TC38E2G1		
#6 AWG STRANDED	YA6C-2TC38	256-30695-1158	BBLU-6D-2TC38
#4 AWG STRANDED	YA4C-2TC38	256-30695-1159	BBLU-4D-2TC38
#2 AWG STRANDED	YA2C-2TC38	256-30695-1160	BBLU-2D-2TC38
#2 AWG SOLID	YA3C-2TC38	256-30695-1160	BBLU-3D-2TC38
#1/0 AWG STRANDED	YA25-2TC38	256-30695-1162	BBLU-1/OD-2TC38
#2/0 AWG STRANDED	YA26-2TC38	256-30695-1116	BBLU-2/OD-2TC38
#3/0 AWG STRANDED	YA27-2TC38	54816BE	BBLU-3/OD-2TC38
#4/0 AWG STRANDED	YA28-2TC38	256-30695-1117	BBLU-4/OD-2TC38

NOTES

1. ALL CONNECTIONS TO GROUND BUS BAR SHALL BE WITH 2 HOLE TONGUE LONG BARREL COMPRESSION LUGS BOLTED TO THE BUS BAR.
2. GROUND WIRE CONNECTIONS TO EQUIPMENT SHALL BE WITH 2 HOLE TONGUE LONG BARREL COMPRESSION LUGS BOLTED TO THE DEVICE OR WITH THE RESPECTIVE EQUIPT MANUFACTURER'S LUG OR TERMINAL WHERE APPLICABLE.
3. GROUNDING ELECTRODE CONDUCTORS, BONDING JUMPERS, & INDIVIDUAL GROUND WIRES SHALL NOT BE INSTALLED IN METAL CONDUIT. WHERE PLASTIC CONDUIT IS USED FOR INDIVIDUAL GROUND WIRES, DO NOT COMPLETELY ENCIRCLE THE CONDUIT WITH FERROUS AND/OR MAGNETIC MATERIALS. WHERE METAL CLAMPS ARE INSTALLED USE NYLON BOLTS, NUTS, WASHERS, & SPACERS TO INTERRUPT A COMPLETE METALLIC APTH FROM ENCIRCLING THE CONDUIT.
4. ALL CONNECTIONS SHALL BE COATED WITH A CORROSION PREVENTATIVE COMPOUND (SANCHEM INC. NO-OX-ID "A-SPECIAL", BURNDY PENETROX E, OR EQUAL) BEFORE JOINING. ALL COPPER BUS BARS SHALL BE CLEANED PRIOR TO MAKING CONNECTIONS TO REMOVE SURFACE OXIDATION. CLEAN SURFACES, OF RESPECTIVE DEVICES TO BE BONDED, TO BARE METAL, PER NEC 250-12.

GROUNDING LUG CONNECTION DETAIL

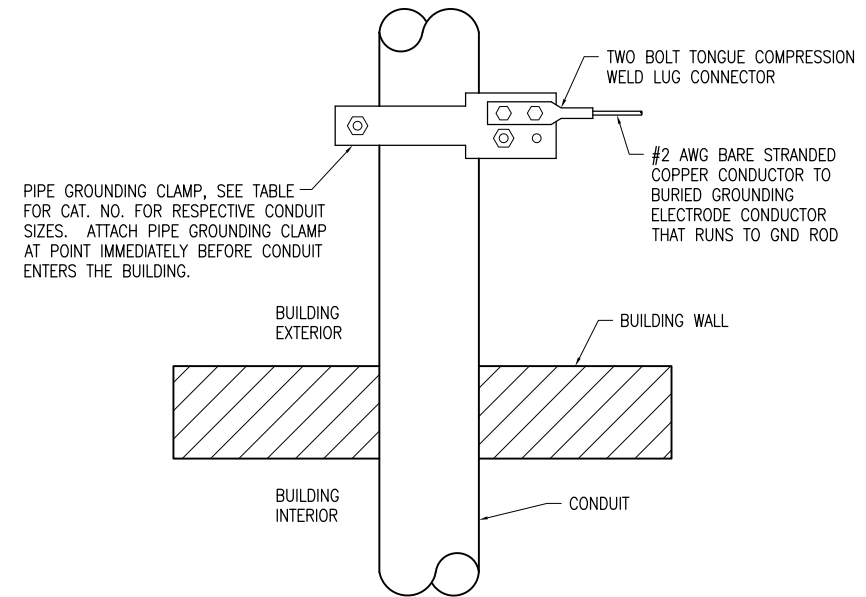

PIPE GROUNDING CLAMP TABLE	
BURNDY CAT. NO.	CONDUIT SIZE
GAR3902TC	1/2" - 1"
GAR3903TC	1 1/4" - 2"
GAR3904TC	2 1/2" - 3 1/2"
GAR3905TC	4" - 5"
GAR3906TC	6"
GAR3907TC	8"

NOTES

1. EXTERIOR CONDUIT GROUNDING IS REQUIRED FOR THE PHOTOCCELL CONDUIT, RADIO ANTENNA CONDUIT, & OTHER CONDUITS EXTENDING TO THE ROOF LEVEL.
2. CONNECTIONS TO BURIED GROUNDING ELECTRODE CONDUCTOR SHALL BE EXOTHERMIC WELD.

EXTERIOR CONDUIT GROUNDING DETAIL

NOV 23, 2011 12:42 PM WALLE00723
 pw:\sps-sv306.hanson.com\Projects\Documents\10401390\10401390\CAD\Airport\Sheet\E-507-GND

REVISION	DATE

ROCHELLE MUNICIPAL AIRPORT
 MAJOR THOMAS F. KORITZ FIELD
 ROCHELLE, ILLINOIS
 I.L. PROJ.: RPJ-4136 A.I.P. PROJ.: 3-17-0087-B14

Hanson Project No. 10401390	10/21/11
Filename E-507-GND.dwg	JFC
Scale AS SHOWN	JFC
Date 11/22/11	10/21/11
LAYOUT	REVIEWED
DRAWN	CHK/KNL

HANSON
 © Copyright Hanson Professional Services Inc. 2011
 Hanson Professional Services Inc.
 1525 South Sixth Street
 Springfield, Illinois 62703-2886
 Ph: (217) 788-2450 Fax: (217) 788-2503
 www.hanson-inc.com
 Offices Nationwide

CONSTRUCT ELECTRICAL VAULT
 GROUNDING DETAILS

GROUNDING NOTES

1. THE CONTRACTOR SHALL FURNISH AND INSTALL ALL GROUNDING AS MAY BE NECESSARY OR REQUIRED TO MAKE A COMPLETE GROUNDING SYSTEM AS REQUIRED BY THE LATEST NATIONAL ELECTRICAL CODE (NFPA 70) IN FORCE AND FAA-STD-019e (LIGHTNING AND SURGE PROTECTION, GROUNDING, BONDING, AND SHIELDING REQUIREMENTS FOR FACILITIES AND ELECTRONIC EQUIPMENT). THE RELIABILITY OF THE GROUNDING SYSTEM IS DEPENDENT ON CAREFUL, PROPER INSTALLATION AND CHOICE OF MATERIALS. IMPROPER PREPARATION OF SURFACES TO BE JOINED TO MAKE AN ELECTRICAL PATH, LOOSE JOINTS OR CORROSION CAN INTRODUCE IMPEDANCE THAT WILL SERIOUSLY IMPAIR THE ABILITY OF THE GROUND PATH TO PROTECT PERSONNEL AND EQUIPMENT AND TO ABSORB TRANSIENTS THAT CAN CAUSE NOISE IN COMMUNICATIONS CIRCUITS. THE FOLLOWING FUNCTIONS ARE PARTICULARLY IMPORTANT TO ENSURE A RELIABLE GROUND SYSTEM:
 2. FURNISH AND INSTALL GROUND RODS AS DETAILED HEREIN. GROUND RODS FOR AIRFIELD LIGHTING (RUNWAY LIGHTING, TAXIWAY LIGHTING, TAXI GUIDANCE SIGNS, & DISTANCE REMAINING SIGNS) SHALL BE MINIMUM 5/8-IN. DIAMETER BY 8-FT LONG, UL-LISTED COPPER CLAD WITH 10-MIL MINIMUM COPPER COATING. GROUND RODS FOR OTHER APPLICATIONS SHALL BE MINIMUM 3/4-IN. DIAMETER BY 10-FT LONG, UL-LISTED, COPPER CLAD WITH 10-MIL MINIMUM COPPER COATING. GROUND RODS SHALL BE SPACED OR AS DETAILED ON THE RESPECTIVE PLANS, AND IN NO CASE SPACED LESS THAN ONE ROD LENGTH APART. ALL CONNECTIONS TO GROUND RODS AND THE GROUND RING SHALL BE MADE WITH EXOTHERMIC WELD TYPE CONNECTORS, CADWELD BY ERICO PRODUCTS, INC., SOLON, OHIO, (PHONE 1-800-248-9353), THERMOWELD BY CONTINENTAL INDUSTRIES, INC., TULSA, OKLAHOMA (PHONE 918-663-1440) ULTRAWELD BY HARGER, GRAYSLAKE, ILLINOIS (PHONE 1-800-842-7437) OR APPROVED EQUAL. EXOTHERMIC WELD CONNECTIONS SHALL BE INSTALLED IN CONFORMANCE WITH THE RESPECTIVE MANUFACTURER'S DIRECTIONS USING MOLDS AS REQUIRED FOR EACH RESPECTIVE APPLICATION. BOLTED CONNECTIONS WILL NOT BE PERMITTED AT GROUND RODS OR AT BURIED GROUNDING ELECTRODE CONDUCTORS.
 3. CONTRACTOR SHALL TEST EACH MADE ELECTRODE GROUND ROD/GROUND FIELD/GROUND RING WITH AN INSTRUMENT SPECIFICALLY DESIGNED FOR TESTING GROUND FIELD SYSTEMS. IF GROUND RESISTANCE EXCEEDS 10 OHMS, CONTACT THE ENGINEER FOR FURTHER DIRECTION. COPIES OF GROUND FIELD TEST RESULTS SHALL BE FURNISHED TO THE RESIDENT ENGINEER, UPON REQUEST, FOR REVIEW AND RECORD PURPOSES.
 4. ALL PRODUCTS ASSOCIATED WITH THE GROUNDING SYSTEM SHALL BE UL-LISTED AND LABELED.
 5. ALL BOLTED OR MECHANICAL CONNECTIONS SHALL BE COATED WITH A CORROSION PREVENTATIVE COMPOUND BEFORE JOINING, SANCHEM INC. "NO-OX-ID "A-SPECIAL" COMPOUND, BURNDY PENETROX E, OR APPROVED EQUAL.
 6. METALLIC SURFACES TO BE JOINED SHALL BE PREPARED BY THE REMOVAL OF ALL NON-CONDUCTIVE MATERIAL, PER 2011 NATIONAL ELECTRICAL CODE ARTICLE 250-12. ALL COPPER BUS BARS MUST BE CLEANED PRIOR TO MAKING CONNECTIONS TO REMOVE SURFACE OXIDATION.
 7. METALLIC RACEWAY FITTINGS SHALL BE MADE UP TIGHT TO PROVIDE A PERMANENT LOW IMPEDANCE PATH FOR ALL CIRCUITS. METAL CONDUIT TERMINATIONS IN ENCLOSURES SHALL BE BONDED TO THE ENCLOSURE WITH UL-LISTED FITTINGS SUITABLE FOR GROUNDING. PROVIDE GROUNDING BUSHINGS WITH BONDING JUMPER FOR ALL METAL CONDUITS ENTERING SERVICE EQUIPMENT (METER BASE, CT CABINET, MAIN SERVICE BREAKER ENCLOSURE, ETC.). PROVIDE GROUNDING BUSHINGS WITH BONDING JUMPER FOR ALL METAL CONDUITS ENTERING AN ENCLOSURE THROUGH CONCENTRIC OR ECCENTRIC KNOCKOUTS THAT ARE PUNCHED OR OTHERWISE FORMED SO AS TO IMPAIR THE ELECTRICAL CONNECTION TO GROUND. STANDARD LOCKNUTS OR BUSHINGS SHALL NOT BE THE SOLE MEANS FOR BONDING WHERE A CONDUIT ENTERS AN ENCLOSURE THROUGH A CONCENTRIC OR ECCENTRIC KNOCKOUT
 8. ALL CONNECTIONS, LOCATED ABOVE GRADE, BETWEEN THE DIFFERENT TYPES OF GROUNDING CONDUCTORS SHALL BE MADE USING UL-LISTED DOUBLE COMPRESSION CRIMP TYPE CONNECTORS OR UL-LISTED BOLTED GROUND CONNECTORS. FOR GROUND CONNECTIONS TO ENCLOSURES, CASES AND FRAMES OF ELECTRICAL EQUIPMENT NOT SUPPLIED WITH GROUND LUGS THE CONTRACTOR SHALL DRILL REQUIRED HOLES FOR MOUNTING A BOLTED GROUND CONNECTOR. ALL BOLTED GROUND CONNECTORS SHALL BE BURNDY, THOMAS AND BETTS, OR EQUAL. TIGHTEN CONNECTIONS TO COMPLY WITH TIGHTENING TORQUES IN UL STANDARD 486A TO ASSURE PERMANENT AND EFFECTIVE GROUNDING.
 9. ALL METAL EQUIPMENT ENCLOSURES, CONDUITS, CABINETS, BOXES, RECEPTACLES, MOTORS, ETC. SHALL BE BONDED TO THE RESPECTIVE GROUNDING SYSTEM.
 10. PROVIDE ALL BOXES FOR PROPOSED OUTLETS, SWITCHES, CIRCUIT BREAKERS, ETC. WITH GROUNDING SCREWS. PROVIDE ALL PANELBOARD, SWITCHGEAR, ETC., ENCLOSURES WITH GROUNDING BARS WITH INDIVIDUAL SCREWS, LUGS, CLAMPS, ETC., FOR EACH OF THE GROUNDING CONDUCTORS THAT ENTER THEIR RESPECTIVE ENCLOSURES.
 11. EACH NEW FEEDER CIRCUIT AND/OR BRANCH CIRCUIT SHALL INCLUDE AN EQUIPMENT GROUND WIRE. METAL RACEWAY OR CONDUIT SHALL NOT MEET THIS REQUIREMENT. THE EQUIPMENT GROUND WIRE FROM EQUIPMENT SHALL NOT BE SMALLER THAN ALLOWED BY 2011 NEC TABLE 250-122 "MINIMUM SIZE CONDUCTORS OR GROUNDING RACEWAY AND EQUIPMENT." WHEN CONDUCTORS ARE ADJUSTED IN SIZE TO COMPENSATE FOR VOLTAGE DROP, EQUIPMENT-GROUNDING CONDUCTORS SHALL BE ADJUSTED PROPORTIONATELY ACCORDING TO CIRCULAR MIL AREA. ALL EQUIPMENT GROUND WIRES SHALL BE COPPER, EITHER BARE OR INSULATED GREEN IN COLOR. WHERE THE EQUIPMENT GROUNDING CONDUCTORS ARE INSULATED, THEY SHALL BE IDENTIFIED BY THE COLOR GREEN, AND SHALL BE THE SAME INSULATION TYPE AS THE PHASE CONDUCTORS.
12. ALL EXTERIOR METAL CONDUIT, WHERE NOT ELECTRICALLY CONTINUOUS BECAUSE OF MANHOLES, HANDHOLES, NON-METALLIC JUNCTION BOXES, ETC., SHALL BE BONDED TO ALL OTHER METAL CONDUIT IN THE RESPECTIVE DUCT RUN, AND AT EACH END, WITH A COPPER-BONDING JUMPER SIZED IN CONFORMANCE WITH 2011 NEC 250-102. WHERE METAL CONDUITS TERMINATE IN AN ENCLOSURE (SUCH AS A MOTOR CONTROL CENTER, SWITCHBOARD, ETC) WHERE THERE IS NOT ELECTRICAL CONTINUITY WITH THE CONDUIT AND THE RESPECTIVE ENCLOSURE, PROVIDE A BONDING JUMPER FROM THE RESPECTIVE ENCLOSURE GROUND BUS TO THE CONDUIT SIZED PER 2011 NEC 250-102.
13. IT IS THE INTENT OF THIS SPECIFICATION THAT ALL MOTOR FRAMES, PUMP BASES ELECTRICAL EQUIPMENT ENCLOSURES, PANEL HOUSINGS, CONDUITS, BOXES, ETC. HAVE A CONTINUOUS COPPER WIRE GROUND CONNECTION AND SHALL BE POSITIVELY BONDED TO THE RESPECTIVE GROUNDING SYSTEM. CONDUIT CONNECTORS WILL NOT BE CONSIDERED AS ADEQUATE GROUNDING.
14. PROVIDE A POSITIVE GROUND BOND FOR ALL OUTLET BOXES, ELECTRICAL EQUIPMENT ENCLOSURES, GROUNDING RECEPTACLES, TOGGLE SWITCHES, ETC. INSTALL A GROUNDING CONDUCTOR IN ALL WIRE AND CABLE RACEWAYS. GROUND CONDUCTOR TO HAVE 600-VOLT INSULATION AND BE IDENTIFIED BY A CONTINUOUS GREEN COLOR COATING. THEY SHALL BE USED SOLELY FOR GROUNDING PURPOSES AND BE ENTIRELY SEPARATE FROM WHITE GROUNDED NEUTRAL CONDUCTOR, EXCEPT AT SUPPLY SIDE OF SERVICE DISCONNECTING MEANS, WHERE GROUNDING AND NEUTRAL SYSTEMS ARE TO BE CONNECTED TO SERVICE GROUND.
15. EACH AND ALL GROUNDED CASED AND METAL PARTS ASSOCIATED WITH ELECTRICAL EQUIPMENT SHALL BE TESTED FOR CONTINUITY OF CONNECTION WITH GROUND BUS SYSTEM BY CONTRACTOR IN PRESENCE OF OWNER'S REPRESENTATIVE.
16. ALL CONNECTIONS BETWEEN THE DIFFERENT TYPES OF GROUNDING CONDUCTORS ABOVE GRADE SHALL BE MADE USING BOLTED GROUND CONNECTORS. GROUND LUGS SHALL BE PROVIDED IN ALL ENCLOSURES AND WIRING TERMINATION JUNCTION BOXES. EQUIPMENT GROUNDS AND GROUNDING CONDUCTOR SHALL BE CONNECTED TO THESE GROUND LUGS. FOR GROUND CONNECTIONS TO ENCLOSURES, CASES AND FRAMES OF ELECTRICAL EQUIPMENT NOT SUPPLIED WITH GROUND LUGS THE CONTRACTOR SHALL DRILL REQUIRED HOLES FOR MOUNTING A BOLTED GROUND CONNECTOR. ALL BOLTED GROUND CONNECTORS SHALL BE BURNDY, OR EQUAL.
17. BOND ALL NONCURRENT-CARRYING PARTS OF METAL EQUIPMENT TO GROUND SYSTEM.
18. BUILDING STRUCTURAL STEEL SYSTEM SHALL BE BONDED TO ELECTRICAL GROUND SYSTEM.
19. INSTALL GROUNDING ELECTRODE CONDUCTORS, LIGHTNING PROTECTION DOWN CONDUCTORS AND SEPARATE GROUND CONDUCTORS IN SCHEDULE 40 OR SCHEDULE 80 PVC CONDUIT OR EXPOSED WHERE ACCEPTABLE TO LOCAL CODES. WHERE GROUNDING ELECTRODE CONDUCTORS, LIGHTNING PROTECTION DOWN CONDUCTORS OR INDIVIDUAL GROUND CONDUCTORS ARE RUN IN PVC CONDUIT, DO NOT COMPLETELY ENIRCLE CONDUIT WITH FERROUS AND/OR MAGNETIC MATERIALS. USE NON-METALLIC REINFORCED FIBERGLASS STRUT SUPPORT. WHERE METAL CONDUIT CLAMPS ARE INSTALLED, USE NYLON BOLTS, NUTS, WASHERS AND SPACERS TO INTERRUPT A COMPLETE METALLIC PATH FROM ENCIRCLING THE CONDUIT. THIS IS REQUIRED TO AVOID GIRDLING OF GROUND CONDUCTORS. GIRDLING OF A GROUND CONDUCTOR IS THE RESULT OF PLACING THE CONDUCTOR IN A RING OF MAGNETIC MATERIAL. THIS RING COULD BE A METALLIC CONDUIT, U-BOLT OR STRUT SUPPORT PIPE CLAMP, OR OTHER SUPPORT HARDWARE. THE RESULT OF GIRDLING GROUND CONDUCTORS SIGNIFICANTLY INCREASES THE INDUCTIVE IMPEDANCE OF THE GROUND CONDUCTOR. INDUCTIVE AND CAPACITIVE IMPEDANCE IS A TYPE OF RESISTANCE THAT OPPOSES THE FLOW OF ALTERNATING CURRENT. ANY INCREASE IN THE IMPEDANCE OF A GROUND CONDUCTOR REDUCES ITS ABILITY TO EFFECTIVELY MITIGATE RADIO FREQUENCY NOISE IN THE GROUND SYSTEM. THE CONDITION WHERE A GROUND CONDUCTOR IS GIRDLED DURING A LIGHTNING STRIKE RESULTS IN PHENOMENA KNOWN AS SURGE IMPEDANCE LOADING. SURGE IMPEDANCE LOADING IS A RESULT OF VOLTAGE AND CURRENT REACHING 500,000 VOLTS AND 10,000 AMPS FOR A SHORT DURATION. GIRDLING FURTHER INCREASES THE IMPEDANCE AT LIGHTNING FREQUENCIES OF 100 KILOHERTZ TO 100 MEGAHERTZ. AT THESE POWER AND FREQUENCY LEVELS ANY INCREASE IN THE IMPEDANCE OF THE GROUND CONDUCTOR MUST BE CONTROLLED. DURING LIGHTNING DISCHARGE CONDITIONS A LOW INDUCTIVE IMPEDANCE PATH IS MORE IMPORTANT THAN A LOW DC RESISTANCE PATH.
20. IF LOCAL CODES DICTATE THAT INDIVIDUAL GROUNDING CONDUCTORS MUST BE RUN IN METAL CONDUIT OR RACEWAY, THEN THE CONDUIT OR RACEWAY MUST BE BONDED AT EACH END OF THE RUN WITH A BONDING JUMPER SIZED EQUAL TO THE INDIVIDUAL GROUNDING CONDUCTOR OR AS REQUIRED BY 2011 NEC 250-102. NOTE THIS DOES NOT APPLY TO AC EQUIPMENT GROUNDING CONDUCTORS RUN WITH AC CIRCUITS.
21. WHERE A CONFLICT IS DETERMINED WITH RESPECT TO GROUNDING REQUIREMENTS PER MANUFACTURER INSTALLATION INSTRUCTIONS, NEC, AND/OR THE CONTRACT DOCUMENTS, CONTACT THE RESIDENT ENGINEER OR PROJECT ENGINEER FOR FURTHER DIRECTIONS.

NOV 23, 2011 12:47 PM WALLE00723
 pw:\sps-svr306\hanson.dom\hanson_projects\Documents\10jobs\1040139\1040139D\CAD\Airport\Sheet\E-003-NOI

REVISION	DATE

ROCHELLE MUNICIPAL AIRPORT
 MAJOR THOMAS F. KORITZ FIELD
 ROCHELLE, ILLINOIS

IL PROJ.: RPJ-4136 A.I.P. PROJ.: 3-17-0087-B14

Hanson Project No. 1040139D	File Name E-003-NOI.dwg	Scale AS SHOWN	Date 11/22/11
LAYOUT	JFC	JFC	10/21/11
DRAWN	CAH/KNL	REVIEWED	10/21/11



© Copyright Hanson Professional Services Inc. 2011
Hanson Professional Services Inc.
 1525 South Sixth Street
 Springfield, Illinois 62703-2886
 Ph: (217) 788-2450 Fax: (217) 788-2503
 www.hanson-inc.com
 Offices Nationwide

CONSTRUCT
 ELECTRICAL VAULT

GROUNDING NOTES