

40-13 #91 8-5-05

JEFFERSON

TR

#91

CONTRACT NO. 74073

F.A.P. RTE.	SECTION	COUNTY	TOTAL SHEETS	SHEET NO.
726		JEFFERSON	10	1

D-7 JOINT REPAIR 2005-1

8-5-05 Letting, Item 091

99.5%  
1-13-2006

SEE SHEET 2 FOR INDEX OF SHEETS

STATE OF ILLINOIS DEPARTMENT OF TRANSPORTATION

DIVISION OF HIGHWAYS

# PROPOSED HIGHWAY PLANS

FAP ROUTE 726 (IL 148)

D-7 JOINT REPAIR 2005-1

JEFFERSON COUNTY

C-97-094-04

D-97-054-04

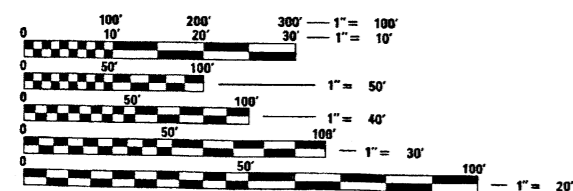
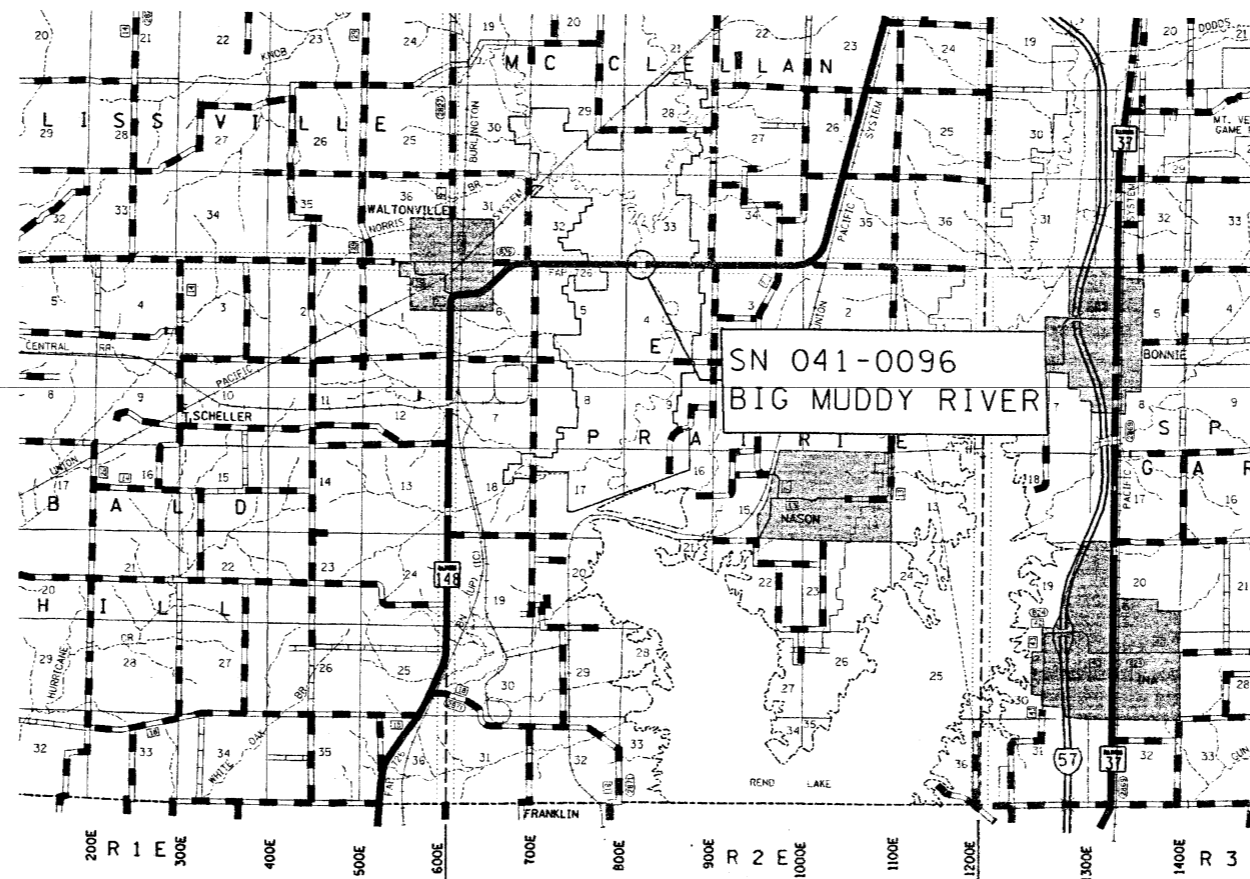

FULL SIZE PLANS HAVE BEEN PREPARED USING STANDARD ENGINEERING SCALES. REDUCED SIZED PLANS WILL NOT CONFORM TO STANDARD SCALES. IN MAKING MEASUREMENTS ON REDUCED PLANS, THE ABOVE SCALES MAY BE USED.

J.U.L.I.E.  
JOINT UTILITY LOCATION INFORMATION FOR EXCAVATION  
1-800-892-0123

CONTRACT NO. 74073 **041-0096** 2004 ADT = 2650

GROSS LENGTH = 646.7 FT  
NET LENGTH = 646.7 FT

STATE OF ILLINOIS  
DEPARTMENT OF TRANSPORTATION  
DIVISION OF HIGHWAYS

SUBMITTED MARCH 29 2005

Christine M. Reed  
DEPUTY DIRECTOR OF HIGHWAYS, REGION FOUR ENGINEER

May 13 2005  
Mike Neal  
ENGINEER OF DESIGN AND ENVIRONMENT

May 13 2005  
Victor Madorsky  
DIRECTOR OF HIGHWAYS, CHIEF ENGINEER

PRINTED BY THE AUTHORITY OF THE STATE OF ILLINOIS

PROJECT ENGINEER : MIKE ALLEN  
SQUAD LEADER : ALEC RING  
DESIGNER : ALEC RING  
TELEPHONE : 217/342-3951 EX 316

F.A.P. RTE.	SECTION	COUNTY	TOTAL SHEETS	SHEET NO.
726	*	JEFFERSON	10	3
STA.		TO STA.		
FED. ROAD DIST. NO.	ILLINOIS	FED. AID PROJECT		

SUMMARY OF QUANTITIES			TOTAL QUANTITIES	CONSTRUCTION TYPE CODE	
CODE NO	ITEM	UNIT		5FTY-2A	
50102400	CONCRETE REMOVAL	CU YD	34.1	34.1	
50300155	NEOPRENE EXPANSION JOINT 2 1/2"	FOOT	68	68	
50300160	NEOPRENE EXPANSION JOINT 4"	FOOT	34	34	
50300255	CONCRETE SUPERSTRUCTURE	CU YD	34.3	34.3	
50800205	REINFORCEMENT BARS, EPOXY COATED	POUND	6296	6296	
51500200	RELOCATING NAME PLATES	EACH	1	1	
67100100	MOBILIZATION	L SUM	1	1	
70100100	TRAFFIC CONTROL AND PROTECTION, STANDARD 701316	EACH	1	1	
70100450	TRAFFIC CONTROL AND PROTECTION, STANDARD 701201	L SUM	1	1	
70103815	TRAFFIC CONTROL SURVEILLANCE	CAL DA	4	4	
70106500	TEMPORARY BRIDGE TRAFFIC SIGNALS	EACH	1	1	
70300100	SHORT-TERM PAVEMENT MARKING	FOOT	57	57	
70300220	TEMPORARY PAVEMENT MARKING - LINE 4"	FOOT	5940	5940	
70301000	WORK ZONE PAVEMENT MARKING REMOVAL	SQ FT	1386	1386	
*78001110	PAINT PAVEMENT MARKING - LINE 4"	FOOT	1942	1942	
*78100300	REPLACEMENT REFLECTOR	EACH	8	8	
78300100	PAVEMENT MARKING REMOVAL	SQ FT	637	637	
X0322050	RAISED REFLECTIVE PAVEMENT MARKER, REFLECTOR REMOVAL	EACH	8	8	
Z0002600	BAR SPLICERS	EACH	40	40	

steffernmk  
 3/29/2005  
 c:\projects\74073\d05404.psdgn  
 SOQ

\*SPECIALTY ITEMS

REVISIONS	
NAME	DATE

ILLINOIS DEPARTMENT OF TRANSPORTATION

## SUMMARY OF QUANTITIES

SCALE: VERT. \_\_\_\_\_  
 HORIZ. \_\_\_\_\_  
 DATE \_\_\_\_\_

DRAWN BY \_\_\_\_\_  
 CHECKED BY \_\_\_\_\_

PLOT DATE = 3/29/2005  
 FILE NAME = #FILE#  
 PLOT SCALE = #SCALE#  
 REFERENCE = #REF#

F.A.P. RTE.	SECTION	COUNTY	TOTAL SHEETS	SHEET NO.
726		JEFFERSON	10	5
STA.		TO STA.		
FED. ROAD DIST. NO.	ILLINOIS	FED. AID PROJECT		



D-T JOINT REPAIRS 2005-1

Structure 041-0096 was constructed in 1980 as an 8 span bridge over the Big Muddy River. The superstructure consists of 5 precast prestressed concrete I-beams supporting a 7-1/2" deck.

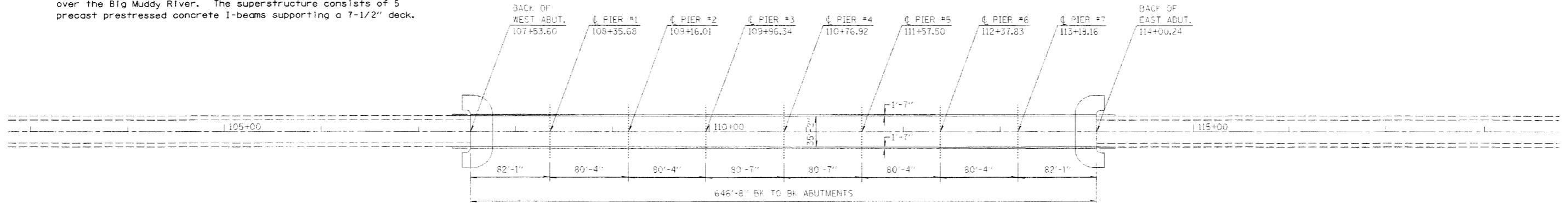

PLAN

GENERAL NOTES

Prior to pouring the new concrete deck, all loose rust, loose mill scale, and other loose potentially detrimental foreign material shall be removed from the surfaces of the beams or girders in contact with concrete. The cost of this work will be included in the pay item covering removal of the existing concrete. All heavy rust and other tightly adhered potentially detrimental foreign matter shall be removed from the surfaces of the beams or girders in contact with concrete. Tightly adhered paint may remain unless otherwise noted. This removal shall be accomplished by methods that will not damage the steel. The cost of the work will be paid for according to Article 109.04 of the Standard Specifications.

The Contractor shall use extreme care during concrete removal so as not to damage the PPC I-Beams.

The removal and reinstallation of the first section of guardrail at each abutment to allow construction of the neoprene expansion joint shall be included in the contract unit price for concrete superstructure.

Reinforcement bars shall conform to the requirements of AASHTO M-31, OR M322 Grade 60.

Plan dimensions and details relative to the existing structure have been taken from existing plans and are subject to nominal construction variations. It shall be the contractor's responsibility to verify such dimensions and details in the field and make necessary approved adjustments prior to construction or ordering of materials. Such variations shall not be cause for additional compensation for a change in the scope of the work; however, the contractor will be paid for the quantity actually furnished at the unit price bid for the work.

Existing reinforcement bars shall be cleaned and incorporated into the new construction. Any reinforcement bars that are damaged during concrete removal operations shall be replaced using an approved bar splicer or anchorage system (cost included in CONCRETE REMOVAL).

Joint openings shall be adjusted according to Article 503.10(c) of the STANDARD SPECIFICATIONS when the deck is poured at an ambient temperature other than 50 degrees Fahrenheit.

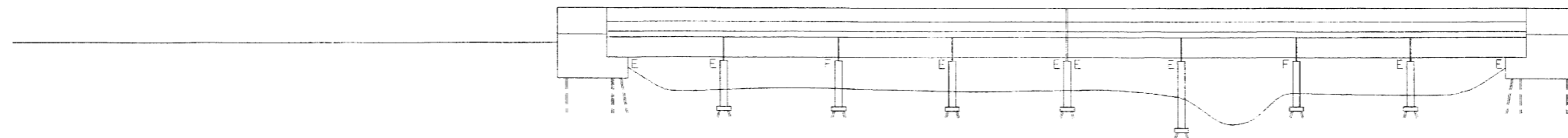

ELEVATION

BILL OF MATERIAL

Concrete Removal	CU YD	34.1
Neoprene Expansion Joint 2 1/2"	FOOT	68
Neoprene Expansion Joint 4"	FOOT	34
Concrete Superstructure	CU YD	34.1
Reinforcement Bars, Epoxy Coated	POUND	6296
Relocating Name Plates	EACH	1
Bar Splicers	EACH	40

REVISIONS	
NAME	DATE

ILLINOIS DEPARTMENT OF TRANSPORTATION

**GENERAL PLAN  
AND ELEVATION  
STR #041-0096**

SCALE: VERT.  
HORIZ.  
DATE

DRAWN BY  
CHECKED BY

steffemk  
 3/29/2005  
 c:\projects\74073d\05404p.dgn

PLOT DATE = 3/29/2005  
 PLOT SCALE = 1/8"=1'-0"  
 PLOT SOURCE = REF  
 REFERENCE = AREF

F.A.P. RTE.	SECTION	COUNTY	TOTAL SHEETS	SHEET NO.
726		JEFFERSON	10	6
STA.	TO STA.			
FED. ROAD DIST. NO.	ILLINOIS	FED. AID PROJECT		
D-7 JOINT REPAIRS 2005-1				

steffemk  
 3/29/2005  
 c:\projects\74073d\05404pe.dgn

STAGE

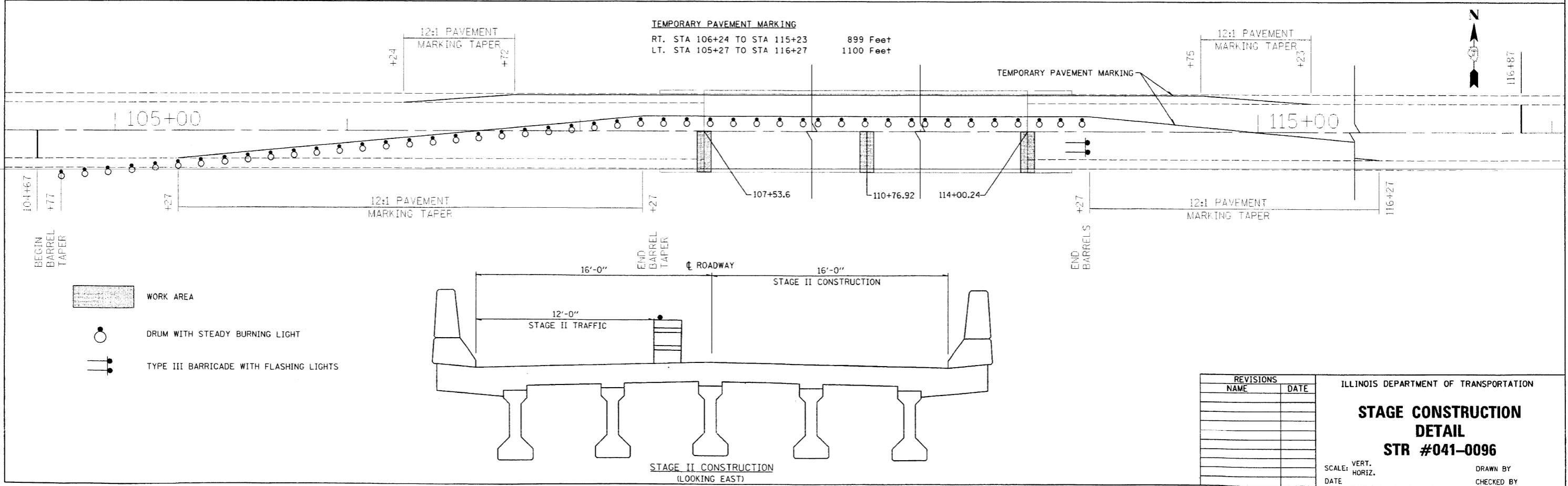
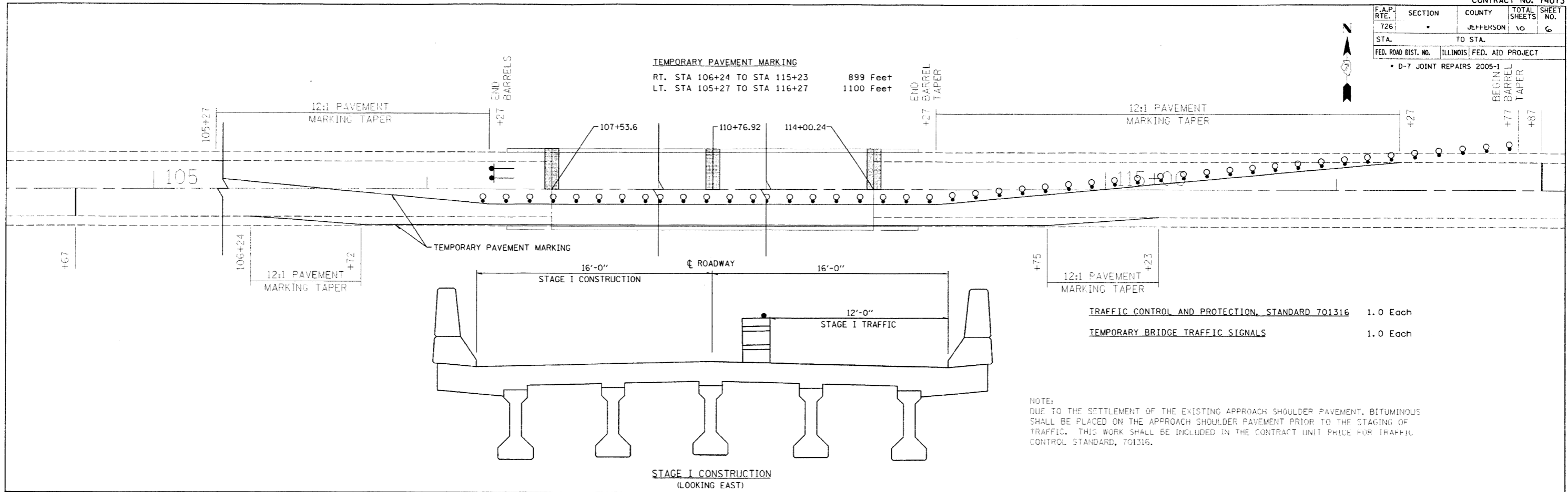

REVISIONS	
NAME	DATE

ILLINOIS DEPARTMENT OF TRANSPORTATION

**STAGE CONSTRUCTION  
 DETAIL**

**STR #041-0096**

SCALE: VERT. \_\_\_\_\_  
 HORIZ. \_\_\_\_\_

DATE \_\_\_\_\_

DRAWN BY \_\_\_\_\_  
 CHECKED BY \_\_\_\_\_

PLOT DATE: 3/29/2005  
 FILE NAME: 05404PE.DGN  
 PLOT SCALE: 1"=40'  
 REFERENCE: 05404PE.DGN



F.A.P. RTE.	SECTION	COUNTY	TOTAL SHEETS	SHEET NO.
726		JEFFERSON	10	7
STA.	TO STA.			
FED. ROAD DIST. NO.	ILLINOIS	FED. AID PROJECT		
• D-7 JOINT REPAIRS 2005-1				

BAR LIST - PER ABUTMENTS - STR #041-0096

BAR	NUMBER OF BARS		TOTAL	SIZE	LENGTH	SHAPE
	STAGE I	STAGE II				
a (E)	8	8	16	#7	15'-1"	
a1(E)	10	10	20	#6	6'-6"	
a2(E)	5	5	10	#6	4'-0"	
d(E)	5	5	10	#4	4'-10"	
d2(E)	5	5	10	#5	4'-1"	
h(E)	4	4	8	#6	15'-0"	
x(E)	26	26	52	#6	6'-11"	
u(E)	16	16	32	#6	2'-8"	

CONCRETE REMOVAL (LIMITS ARE FROM OUT TO OUT OF DECK)

REINFORCEMENT BARS DESIGNATED (E) SHALL BE EPOXY COATED

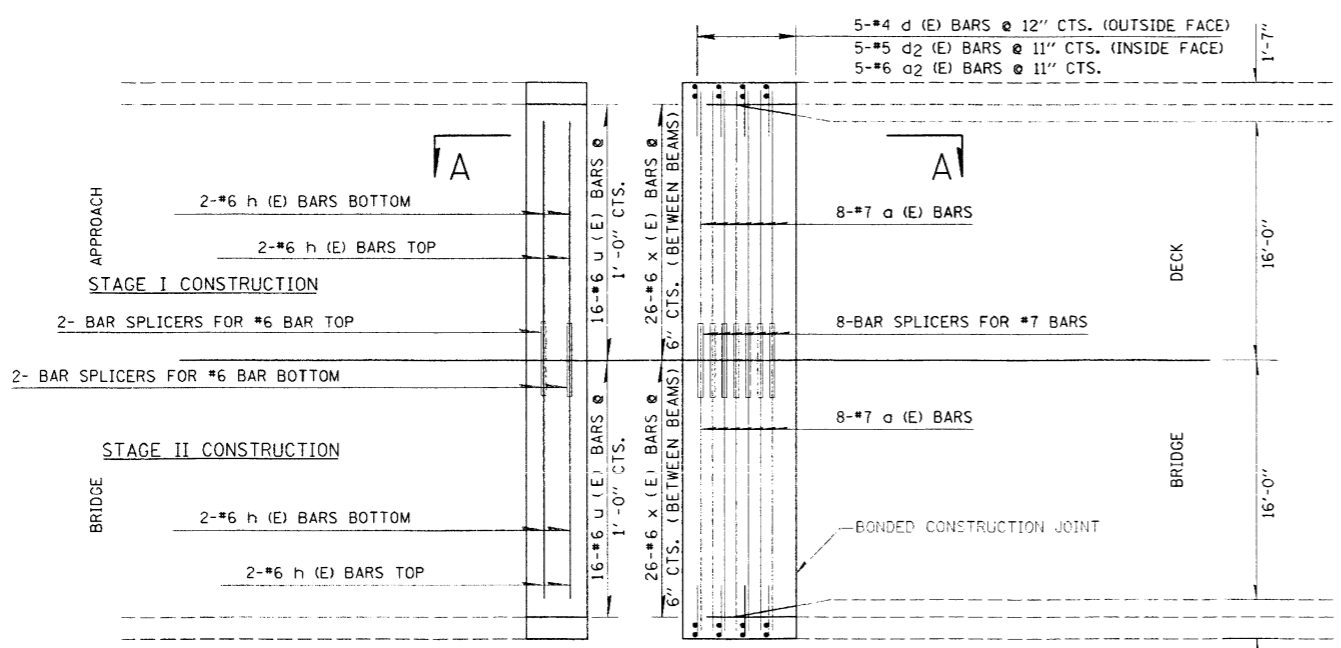

REINFORCEMENT DETAIL  
EAST ABUTMENT (WEST ABUTMENT SIMILAR)

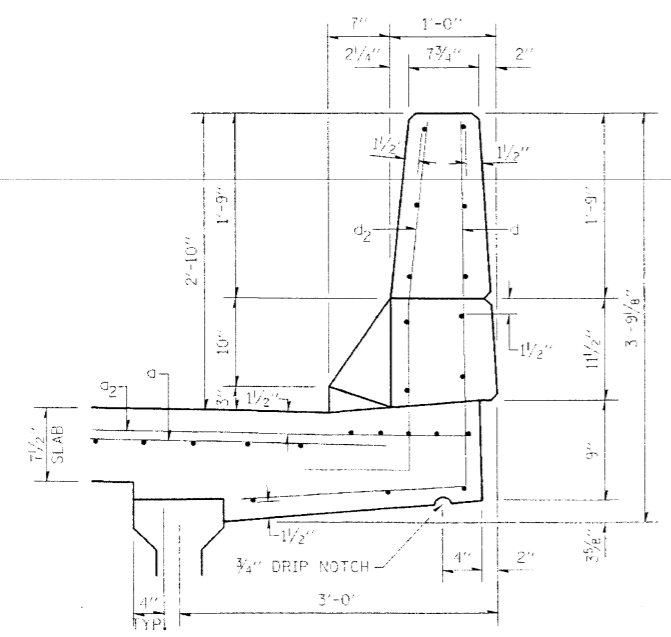

PARAPET DETAIL

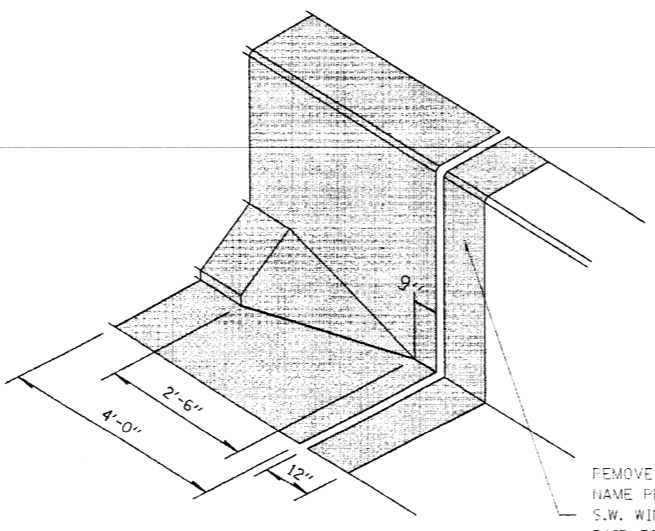

TYPICAL CONCRETE REPLACEMENT  
AT EACH ABUTMENT

REMOVE AND REINSTALL NAME PLATE LOCATED ON S.W. WING STR. 041-0096, PAID FOR AS RELOCATING NAME PLATE 1.0 EACH

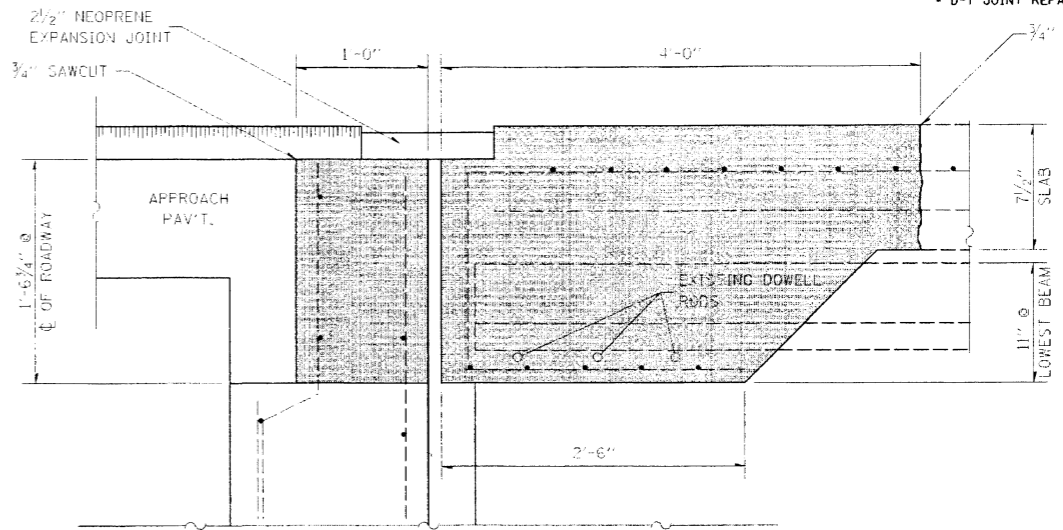

EXISTING EXPANSION JOINTS AT ABUTMENTS

PLACE a1(E) AND h1(E) BARS IN BACK OF ANCHOR BOLT AS SHOWN IF REQUIRED TO MAINTAIN 1" CLEARANCE (+/- 1/8"). ANCHOR BOLTS SHOULD BE TIED TO a1(E) AND h1(E) BARS.

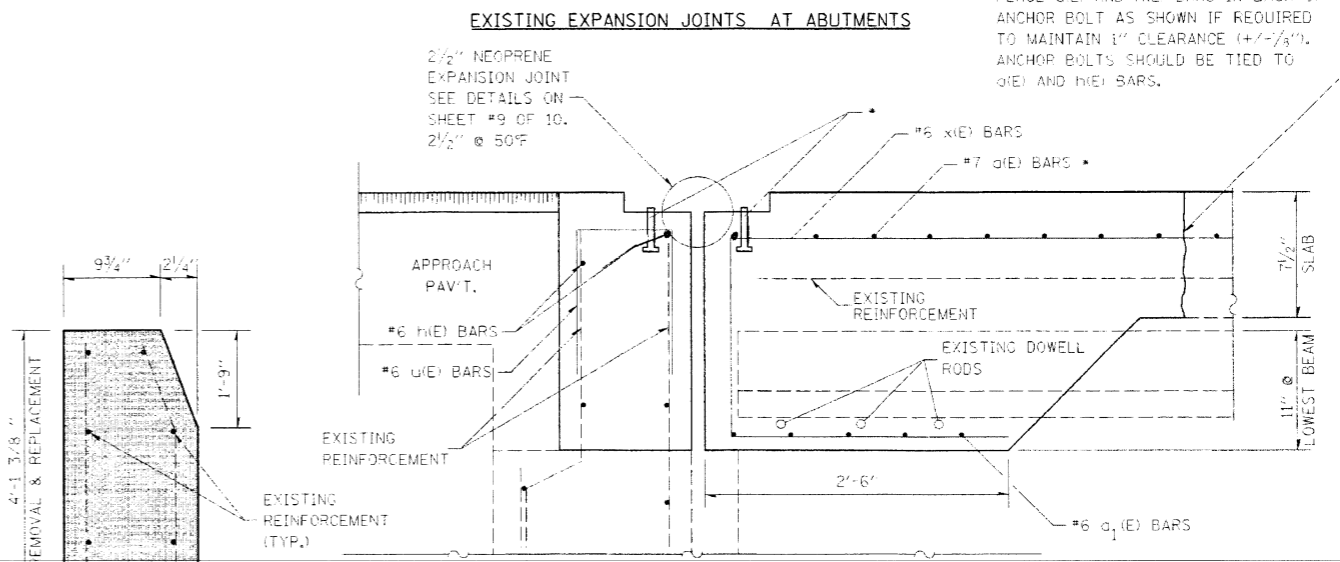

PROPOSED EXPANSION JOINTS AT ABUTMENTS

NOTE: EXISTING REINFORCEMENT BARS AND DOWELL RODS ARE TO BE CLEANED, STRIGHTENED AND INCORPORATED INTO THE NEW CONSTRUCTION. ANY REINFORCEMENT BARS THAT ARE DAMAGED DURING CONCRETE REMOVAL OPERATIONS SHALL BE REPLACED USING AN APPROVED BAR SPLICER OR ANCHORAGE SYSTEM (COST INCLUDED IN CONCRETE REMOVAL).

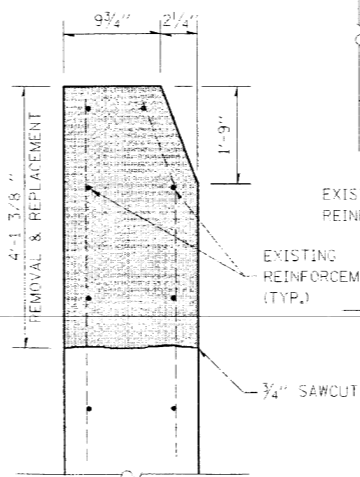

WINGWALL DETAIL

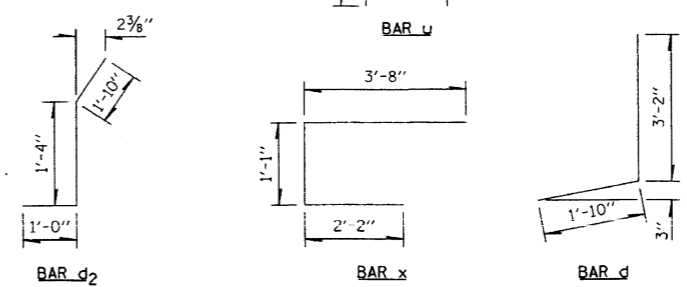

REVISIONS	
NAME	DATE

ILLINOIS DEPARTMENT OF TRANSPORTATION  
**EXPANSION JOINT DETAILS  
EAST & WEST ABUTMENTS  
STR #041-0096**

SCALE: VERT. \_\_\_\_\_  
          HORIZ. \_\_\_\_\_

DRAWN BY \_\_\_\_\_  
CHECKED BY \_\_\_\_\_

steffennk  
 3/29/2005  
 c:\projects\74073\d05404\pa.dgn

PLOT DATE = 3/29/2005  
 FILE NAME = 041E1.dwg  
 PLOT SCALE = 1/8"=1'-0"  
 REFERENCE = 041E1.dwg

F.A.P. RTE.	SECTION	COUNTY	TOTAL SHEET SHEETS NO.
726		JEFFERSON	10 8
STA.	TO STA.		
FED. ROAD DIST. NO.	ILLINOIS	FED. AID PROJECT	

D-7 JOINT REPAIRS 2005-1

BAR LIST - PIER 4 - STR #041-0096

BAR	NUMBER OF BARS		TOTAL	SIZE	LENGTH	SHAPE
	STAGE I	STAGE II				
a (E)	16	16	32	#7	15'-1"	—
a1(E)	20	20	40	#6	6'-6"	—
a2(E)	10	10	20	#6	4'-0"	—
d(E)	10	10	20	#4	4'-10"	J
d1(E)	10	10	20	#5	4'-1"	J
x(E)	52	52	104	#6	6'-11"	—

REINFORCEMENT BARS DESIGNATED (E) SHALL BE EPOXY COATED

CONCRETE REMOVAL (LIMITS ARE FROM OUT TO OUT OF DECK)

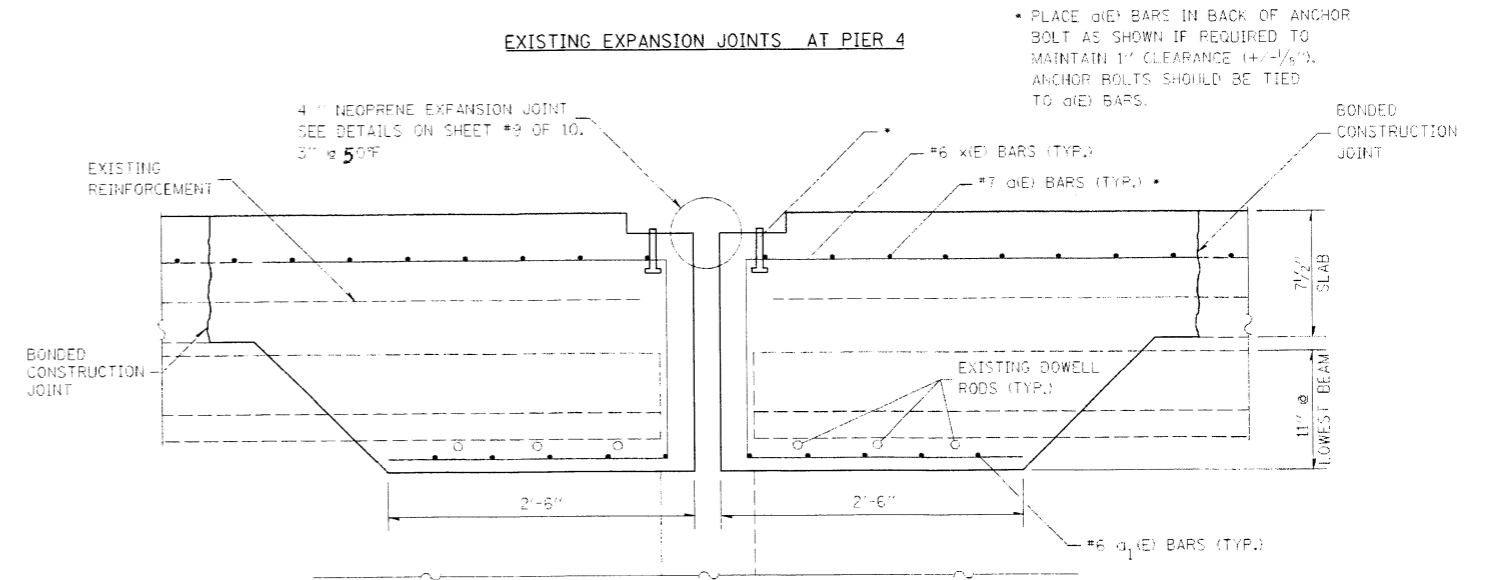
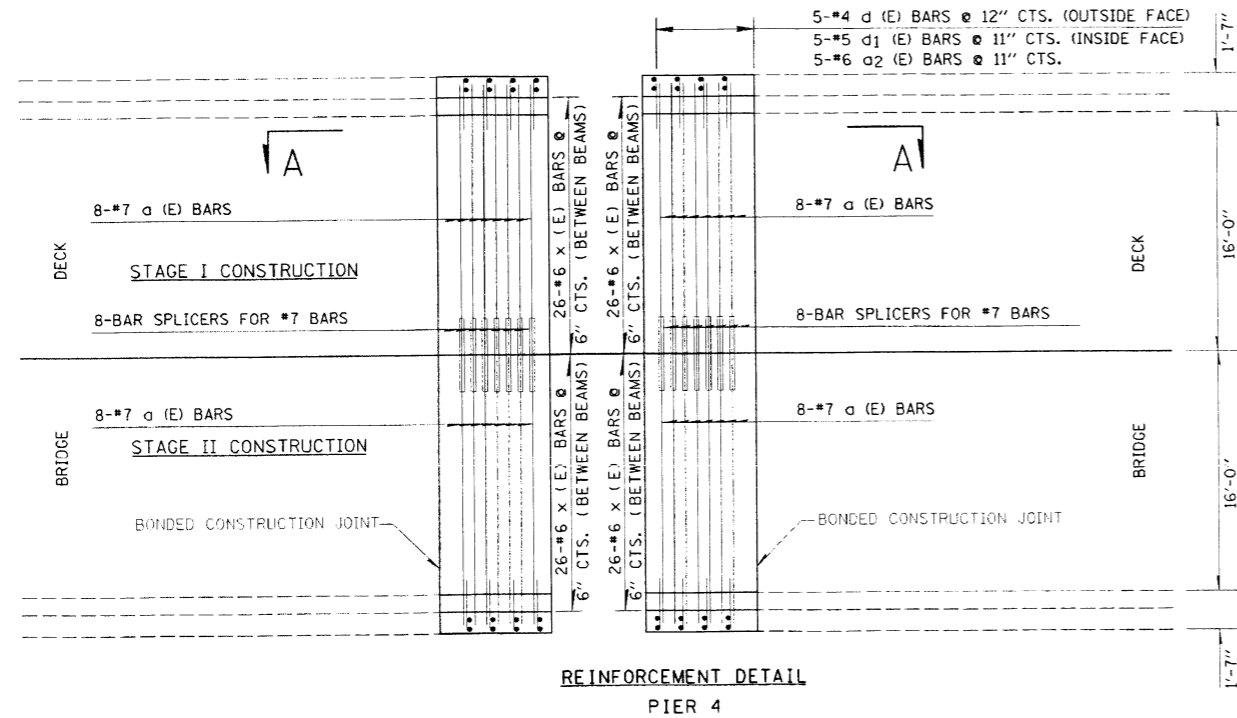
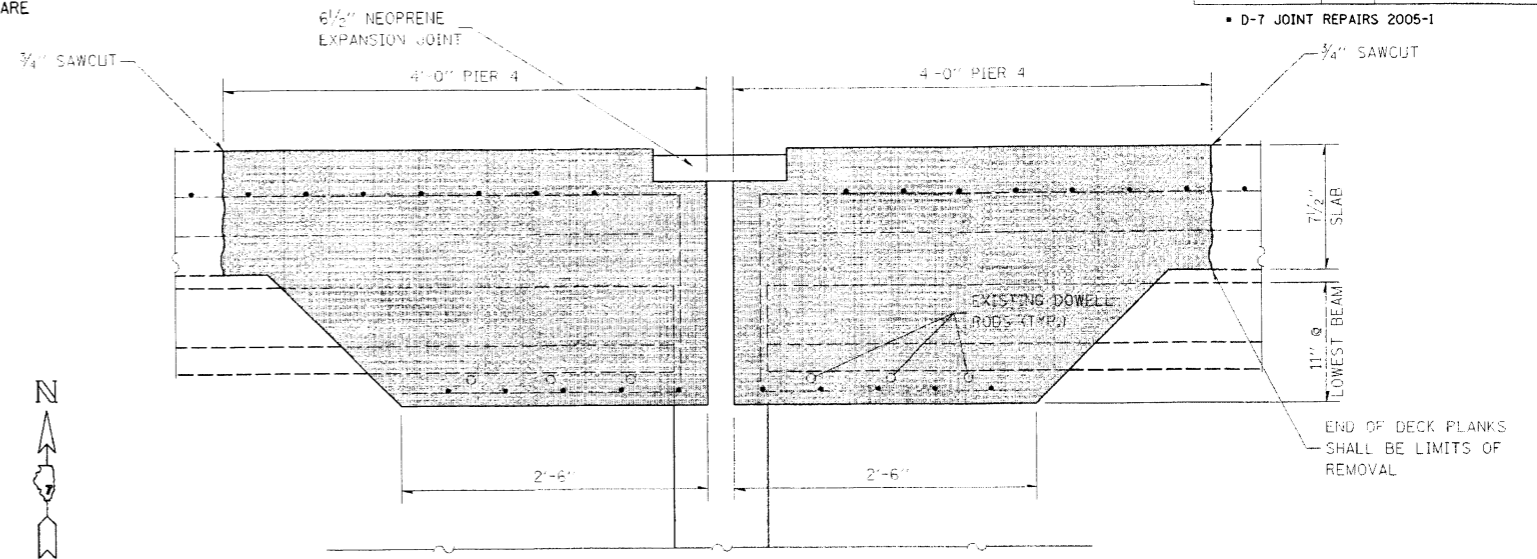

NOTE: EXISTING REINFORCEMENT BARS AND DOWELL RODS ARE TO BE CLEANED, STRIGHTENED AND INCORPORATED INTO THE NEW CONSTRUCTION. ANY REINFORCEMENT BARS THAT ARE DAMAGED DURING CONCRETE REMOVAL OPERATIONS SHALL BE REPLACED USING AN APPROVED BAR SPLICER OR ANCHORAGE SYSTEM (COST INCLUDED IN CONCRETE REMOVAL).

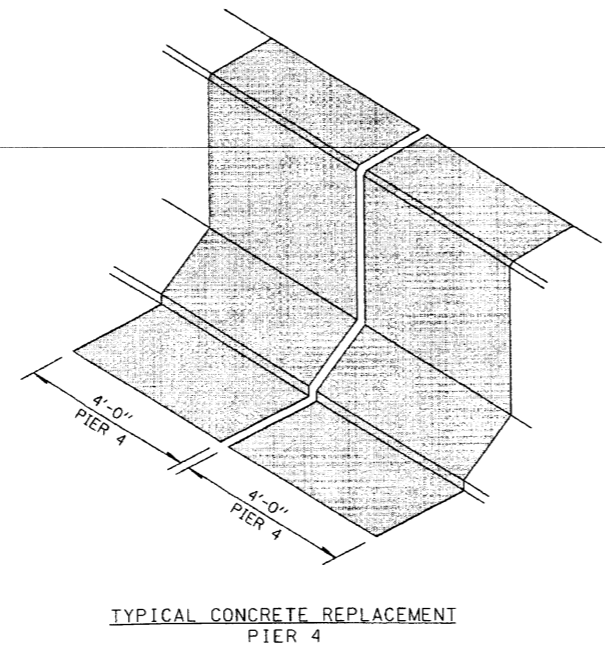
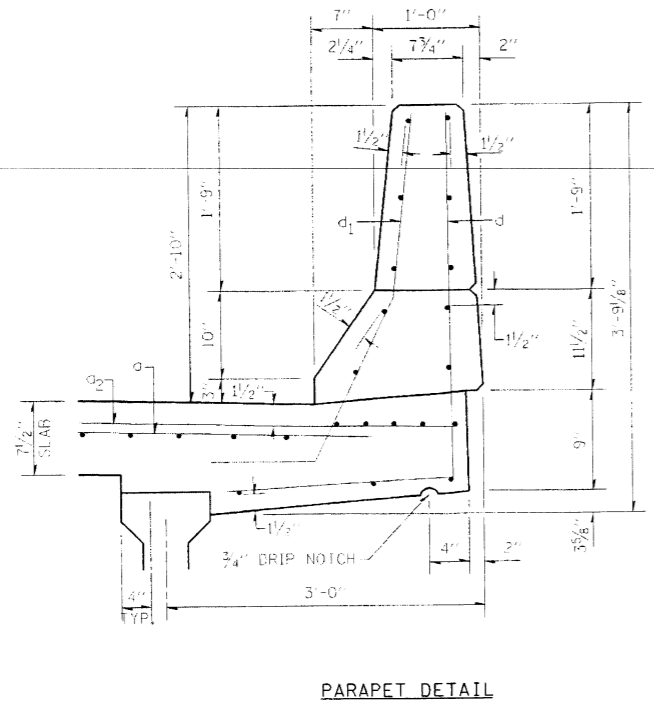
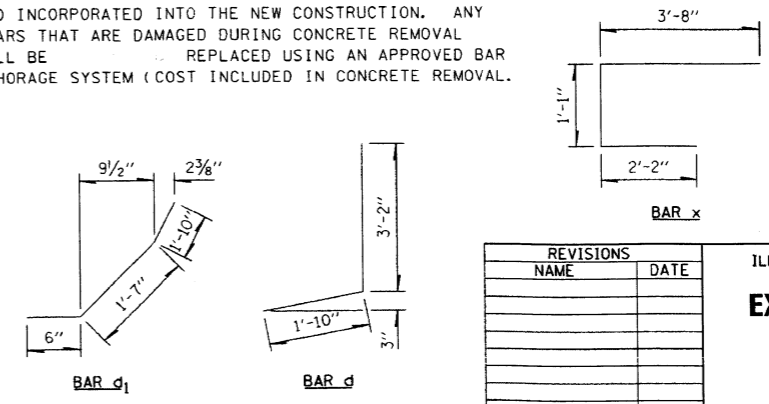

REVISIONS		ILLINOIS DEPARTMENT OF TRANSPORTATION
NAME	DATE	
		<b>EXPANSION JOINT DETAILS</b> <b>PIER 4</b> <b>STR #041-0096</b>

SCALE: VERT. DATE  
HORIZ. DRAWN BY  
CHECKED BY

steffernmk  
 3/29/2005  
 c:\projects\74073\041\0096\041.dgn

PLOT DATE = 3/29/2005  
 PLOT NAME = 041.dgn  
 PLOT SCALE = AS CALLED  
 REFERENCE = #REF#

F.A.P. RTE.	SECTION	COUNTY	TOTAL SHEETS	SHEET NO.
726		JEFFERSON	10	9
STA.		TO STA.		
FED. ROAD DIST. NO.		ILLINOIS FED. AID PROJECT		

• D-7 JOINT REPAIRS 2005-1

Joint Size	"C" at 50°F	"D" at 50°F
2"	2"	1 1/2" Min.
2 1/2"	2 1/2"	1 3/4" Min.
4"	3"	2 1/2" Min.

**INSTALLATION NOTES**

1. Install continuous seal in roadway, parapet, curb, and sidewalk.
2. Install anchor blocks as indicated.

Note A:  
Maximum spacing of anchor bolts shall be 12" centers.

**SKREW LIMITATIONS**

The details of the anchor blocks and the elastomeric membrane in the parapet, as shown, are for up to 50° skews. For skews greater than 50°, the anchor blocks and the elastomeric membrane, installed according to dimension "D", might require modifications to insure a minimum clearance of 1/2" from centerline of anchor studs to edge of parapet opening. The anchor blocks and the elastomeric membrane shall also be installed to the top of the parapet with the anchor studs spaced at ±12" sts.

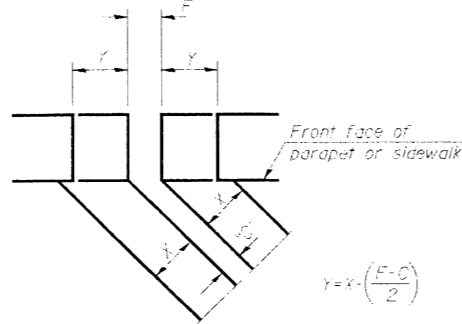

**FORMING BLOCKOUT SKETCH**

$$Y = X - \left( \frac{F - C}{2} \right)$$

For dimension "F" see sheet # 7-8

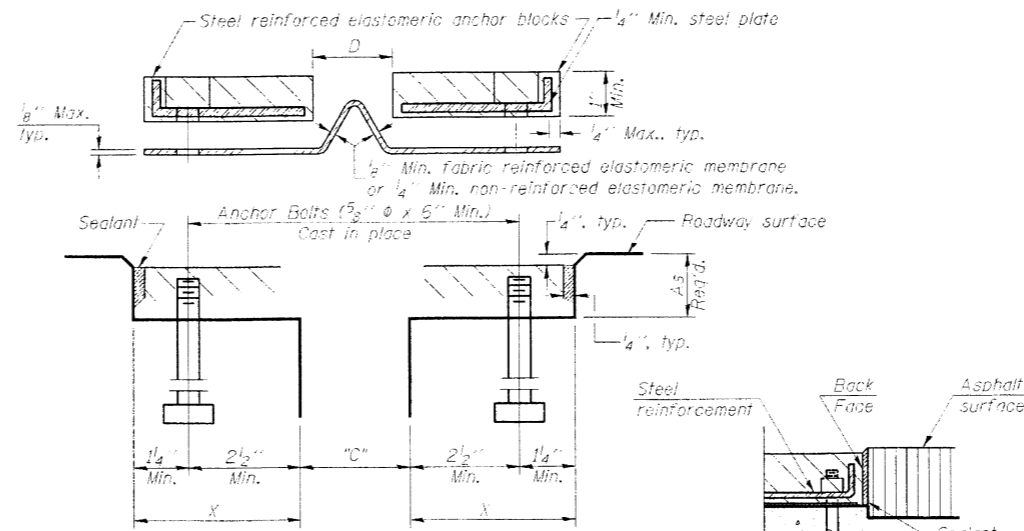

**CROSS SECTION**

**ANCHOR BLOCK WITH ASPHALT SURFACE**

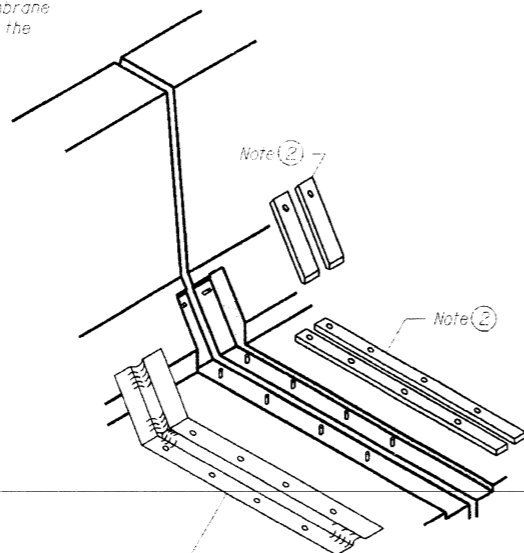

**AT PARAPET**

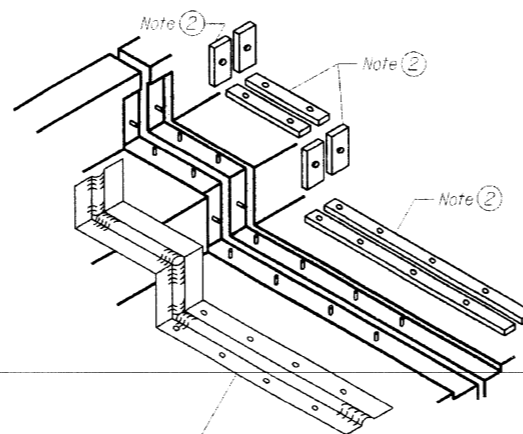

**AT SIDEWALK OR MEDIAN**

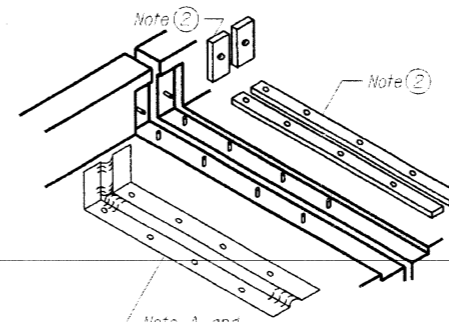

**AT WALL**

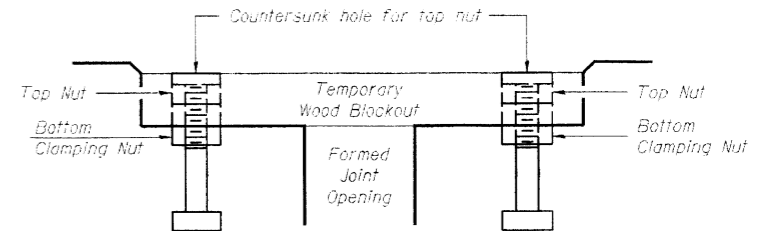

**RECOMMENDED BLOCKOUT DETAIL**

Note:  
Stud needs to be threaded lower to allow for use of clamping nut.

Anchor studs should be stainless

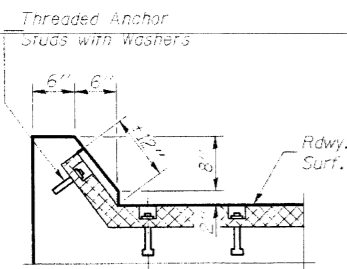

**AT CURB**

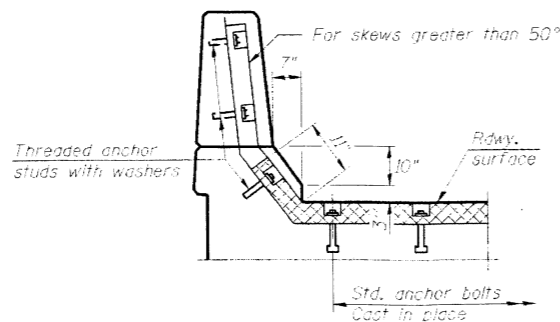

**AT PARAPET**

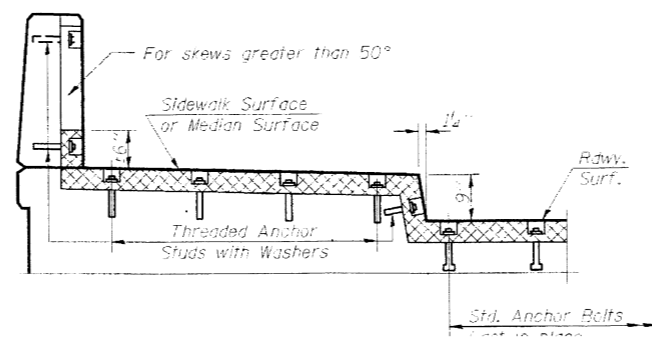

**AT SIDEWALK OR MEDIAN TYPICAL END TREATMENTS**

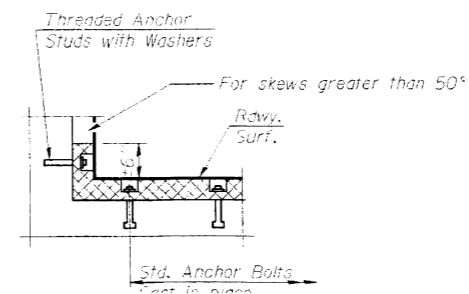

**AT WALL**

**CONTINUOUS SEAL TYPE NEOPRENE EXPANSION JOINTS**

REVISIONS	
NAME	DATE

ILLINOIS DEPARTMENT OF TRANSPORTATION

**CONTINUOUS SEAL TYPE NEOPRENE EXPANSION JOINTS STR #041-0096**

SCALE: VERT. HORIZ. DATE

DRAWN BY CHECKED BY

F.A.P. RTE.	SECTION	COUNTY	TOTAL SHEETS	SHEET NO.
726	*	JEFFERSON	10	10
STA.		TO STA.		
FED. ROAD DIST. NO.	ILLINOIS	FED. AID PROJECT		

D-T JOINT REPAIRS 2005-1

**NOTES**

Bar splicer assemblies shall be of an approved type and shall develop in tension at least 125 percent of the yield strength of the lapped reinforcement bars.  
 Splicer rods shall be of minimum 60 ksi yield strength, threaded or coiled full length.  
 All reinforcement bars shall be lapped and tied to the splicer rods or dowel bars.  
 Bar splicer assemblies shall be epoxy coated according to the requirements for reinforcement bars.

Other systems of similar design may be submitted to the Engineer for approval. Approval shall be based on certified test results from an approved testing laboratory that the proposed bar splicer assembly satisfies the following requirements:

- ① Minimum Capacity =  $1.25 \times f_y \times A_t$   
 (Tension in kips)
- ② Minimum \*Pull-out Strength =  $1.25 \times f_{sallow} \times A_t$   
 (Tension in kips)

Where  $f_y$  = Yield strength of lapped reinforcement bars in ksi.  
 $f_{sallow}$  = Allowable tensile stress in lapped reinforcement bars in ksi (Service Load)  
 $A_t$  = Tensile stress area of lapped reinforcement bars.  
 \* = 28 day concrete

Bar Size to be Spliced	Splicer Rod or Dowel Bar Length	Strength Requirements	
		Min. Capacity kips - tension	Min. Pull-Out Strength kips - tension
#4	1'-8"	14.7	5.9
#5	2'-0"	23.0	9.2
#6	2'-7"	33.1	13.3
#7	3'-5"	45.1	18.0
#8	4'-6"	58.9	23.6
#9	5'-9"	75.0	30.0
#10	7'-3"	95.0	38.0
#11	9'-0"	117.4	46.8

Bar splicer assemblies shall be according to Section 508 of the Standard Specifications, except as noted. The furnishing and installation of bar splicer assemblies will be measured and paid for at the contract unit price each for "BAR SPLICERS."

The diameter of this part is equal or larger than the diameter of bar spliced.

**ROLLED THREAD DOWEL BAR**



\*\* ONE PIECE

Wire Connector

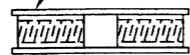

WELDED SECTIONS

**BAR SPLICER ASSEMBLY ALTERNATIVES**

\*\* Heavy Hex Nuts conforming to ASTM A 563, Grade C, D or DH may be used.

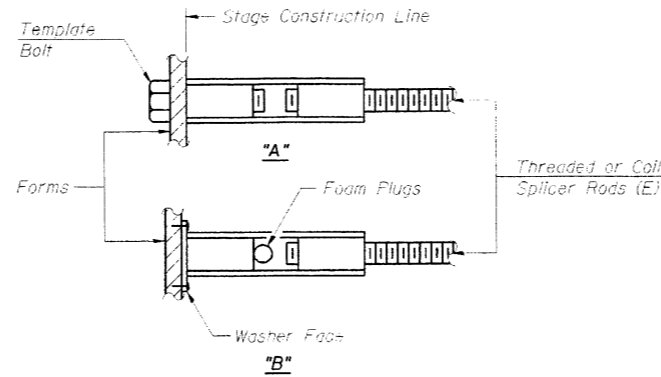

**INSTALLATION AND SETTING METHODS**

"A" : Set bar splicer assembly by means of a template bolt.  
 "B" : Set bar splicer assembly by nailing to wood forms or cementing to steel forms.  
 (E) : Indicates epoxy coating.

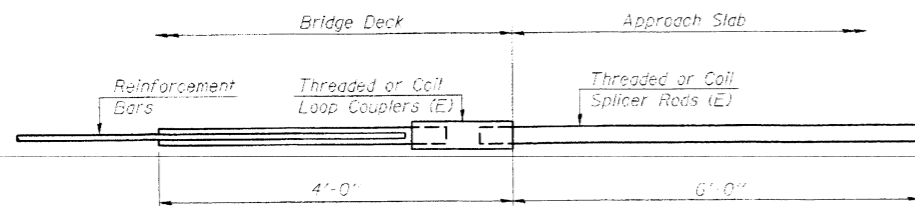

**FOR INTEGRAL OR SEMI-INTEGRAL ABUTMENTS**

Bar Splicer for #5 bar
Min. Capacity = 23.0 kips - tension
Min. Pull-out Strength = 9.2 kips - tension
No. Required =

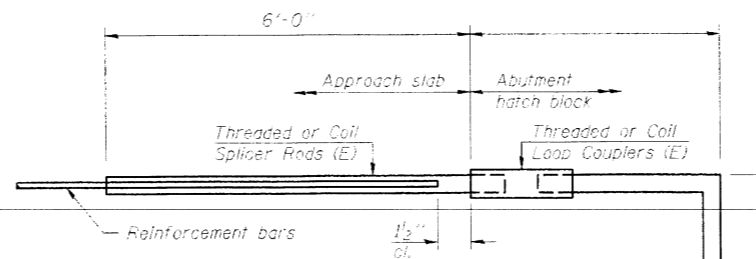

**FOR PILE BENT ABUTMENTS**

Bar Splicer for #5 bar
Min. Capacity = 23.0 kips - tension
Min. Pull-out Strength = 9.2 kips - tension
No. Required =

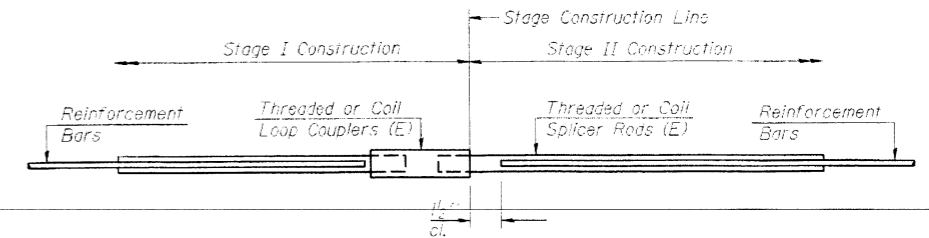

**STANDARD**

Bar Size	No. Assemblies Required	Location
#6	8	E. & W. ABUTMENTS
#7	16	ABUTMENTS
#7	16	PIER 4

REVISIONS	
NAME	DATE

ILLINOIS DEPARTMENT OF TRANSPORTATION

**BAR SPLICER ASSEMBLY DETAILS STR #041-0096**

SCALE: VERT. DATE  
 HORIZ.

DRAWN BY  
 CHECKED BY

steffernk  
 3/29/2005  
 c:\projects\74073\1\05404pa.dgn  
 BDET

PLOT DATE = 3/29/2005  
 PLOT SCALE = 1/8"=1'-0"  
 REFERENCE = #REF\*

Jefferson S.N. 041-0096 (120-BRI-DL)

STATE OF ILLINOIS  
DEPARTMENT OF TRANSPORTATION

S.S.L. ROUTE NO.	SEC.	COUNTY	TOTAL SHEETS	SHEET NO.
FA 726	*	JEFFERSON	4	1

F. H. W. A. REG. NO. 4 ILLINOIS PROJECT  
\*120BRI-DL  
SLT-97-001-90

INDEX OF SHEETS

SHEET NO.	TITLE
1	TITLE SHEET, INDEX OF SHEETS, GENERAL NOTES AND SUMMARY OF QUANTITIES
2	GENERAL PLAN AND ELEVATION
3	EXPANSION JOINT DETAILS
4	CONTINUOUS SEAL TYPE NEOPRENE EXPANSION JOINTS

THE FOLLOWING STANDARDS ARE PART OF THESE PLANS AND ARE INCLUDED AFTER SHEET 4

STANDARD 1868-4	STANDARD SYMBOLS AND ABBREVIATIONS
STANDARD 2298-7	TYPICAL APPLICATION OF TRAFFIC CONTROL DEVICES
STANDARD 2299-10	DESIGN OF TRAFFIC CONTROL DEVICES
STANDARD 2300-3	FLAGGER TRAFFIC CONTROL SIGN
STANDARD 2303-6	TYPICAL APPLICATION OF TRAFFIC CONTROL DEVICES

PLANS FOR PROPOSED  
FEDERAL AID HIGHWAY

DISTRICT 7  
F.A. 726 (ILL. 148)  
SECTION 120BRI-DL  
JEFFERSON COUNTY

STR. NO. 041-0096

GENERAL NOTES

THIS SECTION SHALL BE CONSTRUCTED IN ACCORDANCE WITH THE PLANS, "THE STANDARD SPECIFICATIONS FOR ROAD AND BRIDGE CONSTRUCTION", ADOPTED JULY 1, 1988, "THE STANDARD SPECIFICATIONS FOR TRAFFIC CONTROL ITEMS" ADOPTED APRIL 1, 1983, THE SUPPLEMENTAL SPECIFICATIONS, THE "RECURRING SPECIAL PROVISIONS" AND THE SPECIAL PROVISIONS IN THE PROPOSAL.

THE WORK INCLUDED IN THIS SECTION IS LOCATED ON ILL. ROUTE 148 OVER BIG MUDDY RIVER IN JEFFERSON COUNTY (AT MILE MARKER NO. 8.0) AND CONSISTS OF THE REMOVAL AND REPLACEMENT OF EXISTING EXPANSION JOINTS AND OTHER WORK NECESSARY TO COMPLETE THIS SECTION.

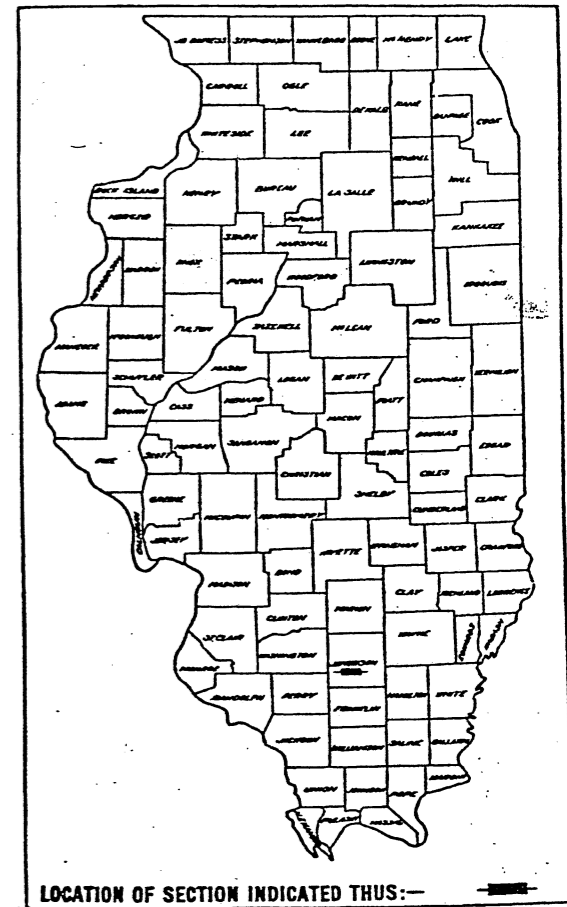

STATE OF ILLINOIS  
DEPARTMENT OF TRANSPORTATION

SUBMITTED: \_\_\_\_\_ BY \_\_\_\_\_

EXAMINED: \_\_\_\_\_ BY \_\_\_\_\_

PASSED: \_\_\_\_\_ BY \_\_\_\_\_

APPROVED: \_\_\_\_\_ BY \_\_\_\_\_

DIRECTOR OF HIGHWAYS

SUMMARY OF QUANTITIES			
CODE NO.	ITEM	UNIT	QUANTITY
50300155	NEOPRENE EXPANSION JOINT 2 1/2"	LIN FT	66
50300165	NEOPRENE EXPANSION JOINT 4"	LIN FT	34
64800450	TRAFFIC CONTROL AND PROTECTION 2303	L SUM	1
65000100	MOBILIZATION	L SUM	1

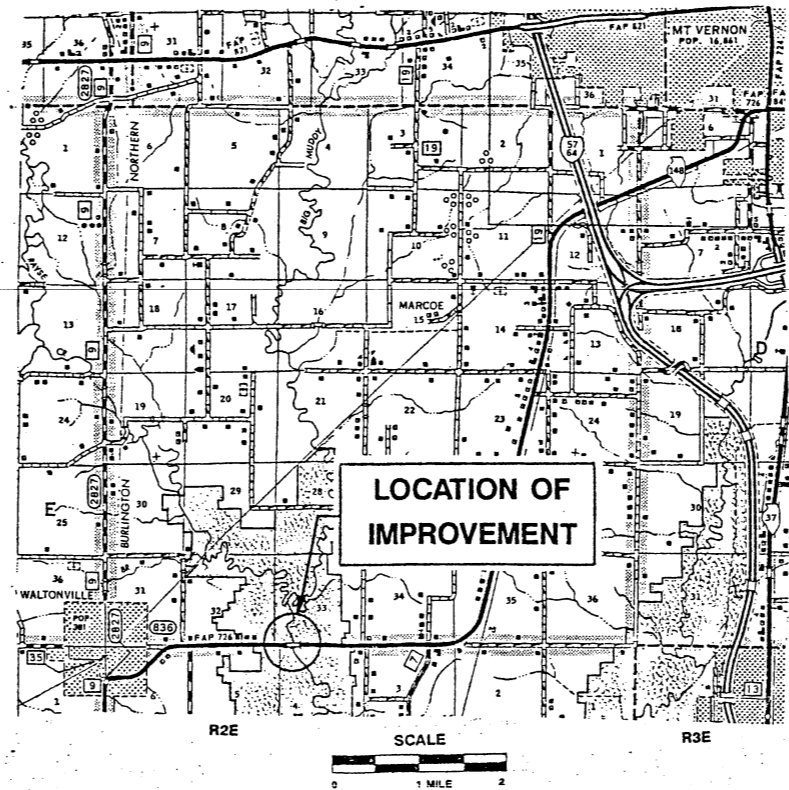

CONTRACT NO.

REEL DL2

STATE OF ILLINOIS  
DEPARTMENT OF TRANSPORTATION

ROUTE NO.	SECTION	COUNTY	TOTAL SHEETS	SHEET NO.
FA 726	*	JEFFERSON	4	2
FED. ROAD DIST. NO. 7	ILLINOIS	FED. AID PROJECT		

\*120BRI-DL

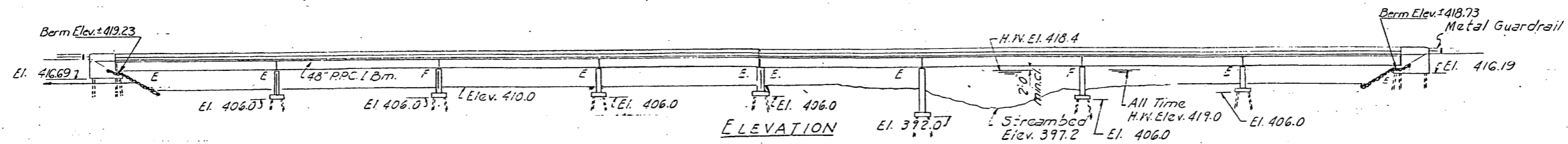

GENERAL NOTES

PLAN DIMENSIONS AND DETAILS RELATIVE TO THE EXISTING STRUCTURE HAVE BEEN TAKEN FROM THE EXISTING PLANS AND ARE SUBJECT TO NOMINAL CONSTRUCTION VARIATIONS. IT SHALL BE THE CONTRACTORS RESPONSIBILITY TO VERIFY SUCH DIMENSIONS AND DETAILS IN THE FIELD AND MAKE NECESSARY APPROVED ADJUSTMENTS PRIOR TO CONSTRUCTION OR ORDERING OF MATERIALS. SUCH VARIATIONS SHALL NOT BE CAUSE FOR ADDITIONAL COMPENSATION FOR A CHANGE IN THE WORK. HOWEVER, THE CONTRACTOR WILL BE PAID FOR THE QUANTITY ACTUALLY FURNISHED AT THE UNIT PRICE BID FOR THE WORK.

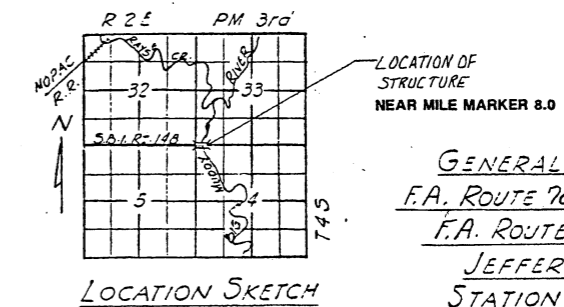
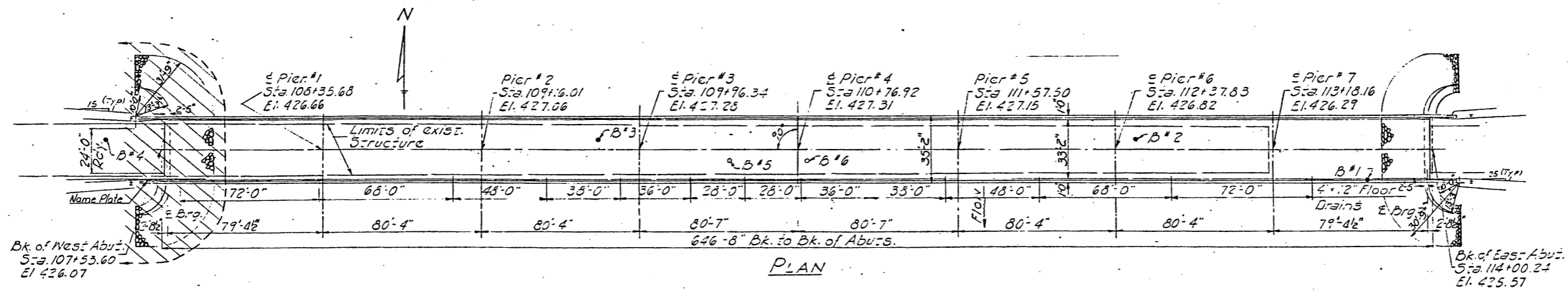

LOCATION OF STRUCTURE  
NEAR MILE MARKER 8.0

GENERAL PLAN AND ELEVATION  
F.A. ROUTE 726 OVER BIG MUDDY RIVER  
F.A. ROUTE 726 SECTION 120 B RI-DL  
JEFFERSON COUNTY  
STATION 110+76.92

CONTRACT NO.

\* 120BRI-DL

INDEX

SHEET NO

- 1
- 2
- 3
- 4

TH  
IN  
ST  
ST  
ST  
ST

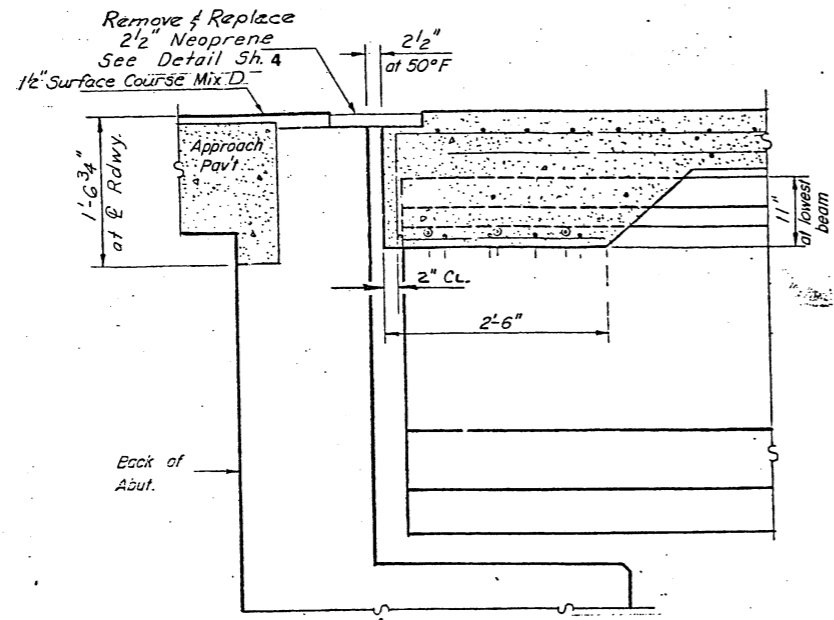

SECTION THRU EXISTING EAST & WEST ABUTMENTS

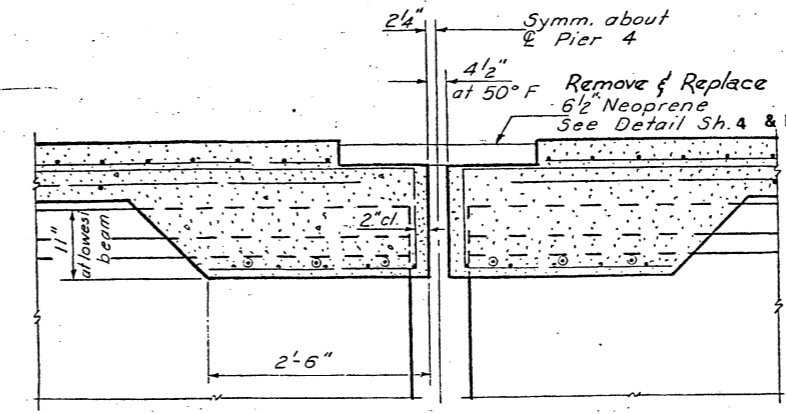

SECTION THRU EXISTING JOINT AT PIER #4

NOTES:  
 SHOULD THE EXISTING ANCHOR BOLTS FAIL TO MATCH THE NEOPRENE EXPANSION JOINT SELECTED, THEY SHALL BE REMOVED AND REPLACED WITH NEW ANCHOR BOLTS OF THE CAPSULE CARTRIDGE TYPE. THESE ANCHORS SHALL BE INSTALLED IN PRE-DRILLED HOLES IN ACCORDANCE WITH THE MANUFACTURERS RECOMMENDED PROCEDURES. THIS WORK SHALL BE CONSIDERED INCIDENTAL TO THE CONTRACT AND NO ADDITIONAL COMPENSATION SHALL BE ALLOWED.

THE EXISTING 6 1/2" NEOPRENE EXPANSION JOINT AT PIER NO. 4 SHALL BE REMOVED AND REPLACED WITH 4" NEOPRENE EXPANSION JOINT. THE AREA BETWEEN THE BACK OF THE NEW 4" ANCHOR BLOCKS AND THE EXISTING CONCRETE DECK SHALL BE FILLED WITH HOT-POURED RUBBERIZED ASPHALT MEETING THE REQUIREMENTS OF ARTICLE 716.04 OF THE STANDARD SPECIFICATIONS (THIS MATERIAL COMPLEIES WITH THE REQUIREMENTS OF ASTM D 3505). THIS WORK IS INCIDENTAL TO THE COST OF NEOPRENE EXPANSION JOINT 4".

~ BILL OF MATERIAL ~		
ITEM	UNIT	QUANTITY
NEOPRENE EXPANSION JOINT 2 1/2"	LIN FT	66
NEOPRENE EXPANSION JOINT 4"	LIN FT	34
TRAFFIC CONTROL AND PROTECTION 2303	L SUM	1
MOBILIZATION	L SUM	1

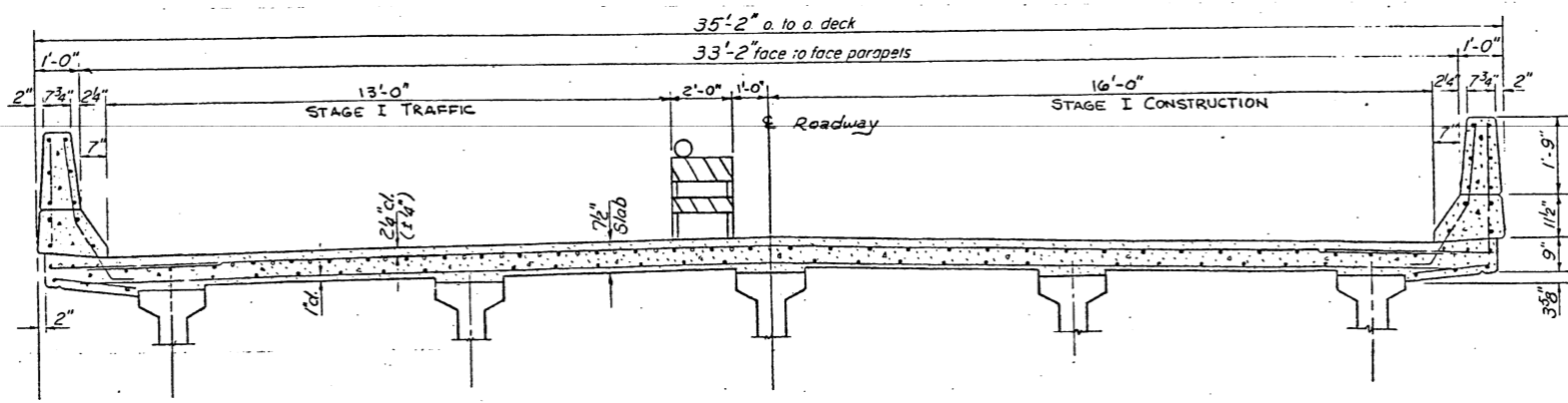

CROSS SECTION OF EXISTING DECK (LOOKING WEST)

FA ROUTE 726 SECTION 120BRI-DL  
 JEFFERSON COUNTY  
 STATION 110+76.92

EXPANSION JOINT DETAILS

CONTRACT NO.

CO  
503  
503  
648  
6501







INDEX OF SHEETS

SHEET NO.	TITLE
1	TITLE SHEET
2-3	TYPICAL SECTIONS
4	GENERAL NOTES
5	SUMMARY OF QUANTITIES
6-7	PLAN & PROFILE SHEETS
8-28	BRIDGE PLANS
29-37	CROSS SECTIONS
37A	TRAFFIC BARRIER TERMINAL TYPE 6 (SPECIAL)

THE FOLLOWING STANDARDS ARE A PART OF THESE PLANS AND ARE ATTACHED AFTER SHEET NO. 37

- STANDARD 1686-4 STANDARD SYMBOLS
- STANDARD 1744-4 STANDARD DESIGN FOR R.O.W. MARKERS
- STANDARD 2230-11 STEEL PLATE BEAM GUARD RAIL
  
- STANDARD 2298-4 TYPICAL APPLICATION TRAFFIC CONTROL DEVICES
- STANDARD 2299-7 STANDARD DESIGN TRAFFIC CONTROL DEVICES
- STANDARD 2300-1 FLAGMAN TRAFFIC CONTROL SIGN
- STANDARD 2302-3 STANDARD DESIGN TRAFFIC CONTROL DEVICES
- STANDARD 2305-3 STANDARD DESIGN TRAFFIC CONTROL DEVICES
- STANDARD 2306-4 STANDARD DESIGN TRAFFIC CONTROL DEVICES
- STANDARD 2307-4 STANDARD DESIGN TRAFFIC CONTROL DEVICES
- STANDARD 2310-3 BRIDGE CONSTRUCTION TRAFFIC CONTROL DEVICES
- STANDARD 2324-3 BRIDGE APPROACH SHOULDER PAVEMENT
  
- STANDARD 2228-4 METAL END SECTION
- STANDARD 2336 TRAFFIC BARRIER TERMINAL TYPE I & IA
  
- STANDARD 2360 BRIDGE APPROACH PAVEMENT
- STANDARD 2113-1 DETAIL OF NAME PLATE FOR BRIDGES
- STANDARD 2237-10 SHOULDER DETAIL

STATE OF ILLINOIS

DEPARTMENT OF TRANSPORTATION

PLANS FOR PROPOSED FEDERAL AID HIGHWAY

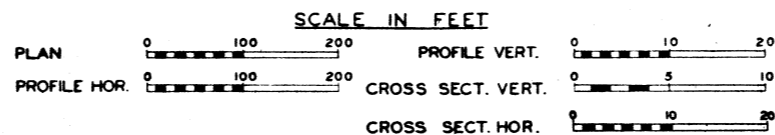

F. A. ROUTE 726  
PROJECT BR-F-726(9)  
SECTION 120BR  
JEFFERSON COUNTY  
C-97-429-71

FEDERAL AID ROUTE NO.	SEC.	COUNTY	TOTAL SHEETS	SHEET NO.
726	120BR	JEFFERSON	37	1

B. P. R. REG. NO. 4 ILLINOIS PROJECT BR-F-726(9)  
P-97-429-70

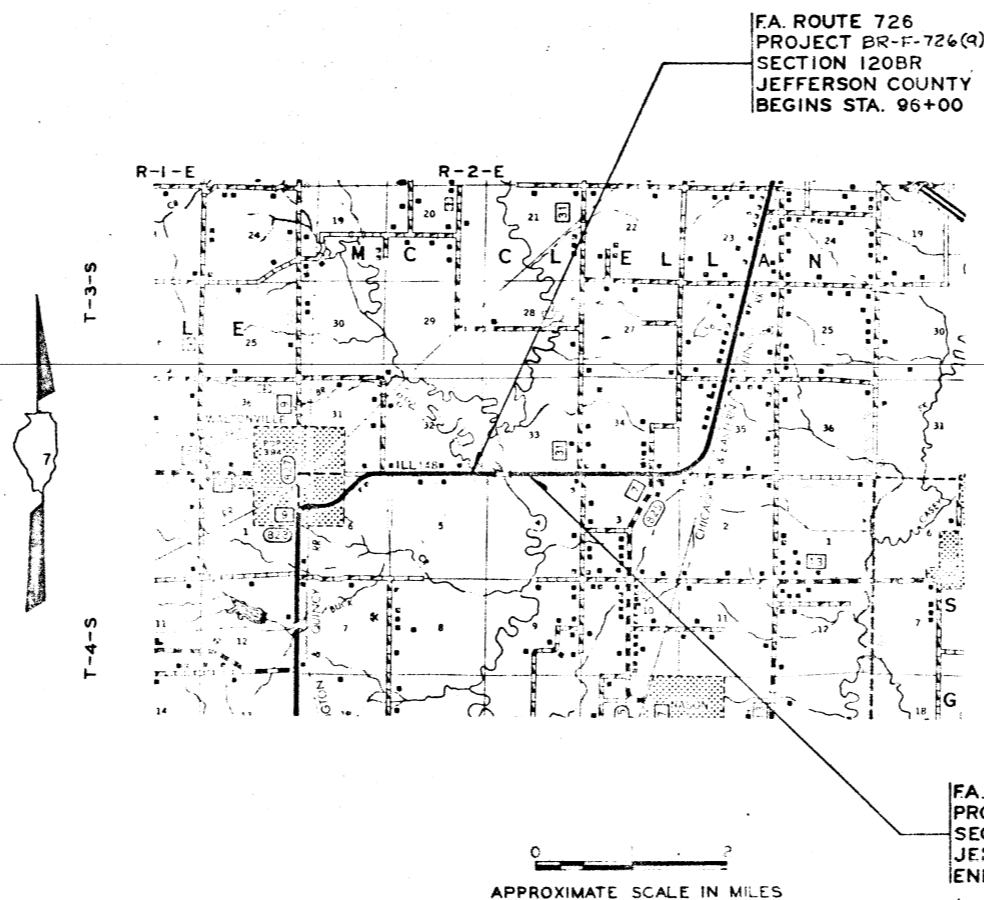
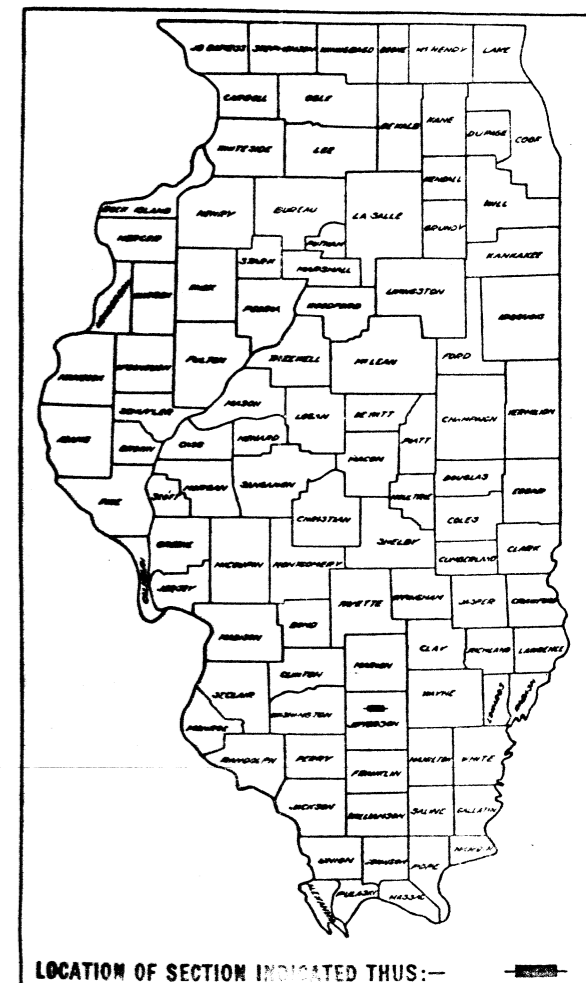

DESIGN DESIGNATION 480(95)  
AREA SERVICE 4 25 (B-20)

NET LENGTH OF PROJECT = 2,900.00 FT. = 0.549 MILES

STATE OF ILLINOIS  
DEPARTMENT OF TRANSPORTATION

SUBMITTED: \_\_\_\_\_ DISTRICT ENGINEER

EXAMINED: \_\_\_\_\_ ASST. DISTRICT ENGINEER

PASSED: \_\_\_\_\_ ASST. DISTRICT ENGINEER

APPROVED: \_\_\_\_\_ ENGINEER OF DESIGN

\_\_\_\_\_  
DIRECTOR OF HIGHWAYS

DEPARTMENT OF TRANSPORTATION  
FEDERAL HIGHWAY ADMINISTRATION

APPROVED: \_\_\_\_\_

\_\_\_\_\_  
DIVISION ADMINISTRATOR

\_\_\_\_\_  
DATE

Branch Work #3 Channel on bank #15 So Side of Ex. St. Bridge  
 Right Sta 108+87.5 Elev 419.84  
 Ex. St. Structure Built as 5 B/Rtc 148 Sec 120 B  
 Sta 111+80 in 1931 Contractor shall remove existing  
 structure after completion of details.  
 No Salvage. Ex. St. Structure No. 041-0037  
 Existing Structure is one 100' span Truss and fifteen I Beam  
 approach spans at 43'-6". Truss and approach spans are  
 24'-8" out to out.

STATE OF ILLINOIS  
 DEPARTMENT OF TRANSPORTATION

ROUTE NO.	SECTION	COUNTY	TOTAL SHEETS	SHEET NO.	SHEET NO. 1 A
P.A. 726	120 BR	Jefferson	37	8	21 SHEETS
FED. ROAD DIST. NO. 7	ILLINOIS	FED. AID PROJECT			

GENERAL NOTES

See Proposal for Boring Data.  
 All structural steel shall be shop painted with two coats of basic lead silico chromate paint.  
 Layout of Stone Rip Rap Walls may be varied in the field to suit ground conditions as directed by the Engineer.  
 The Contractor shall drive 3 Steel HP10x42 test piles, one each in a permanent location at each abutment and pier 4 as directed by the Engineer before ordering the remainder of piles.  
 The embankment configuration shown shall be the minimum embankment that must be constructed prior to construction of the abutments.  
 Reinforcement bars shall conform to the requirements of AASHTO M31 or M53 Grade 60.

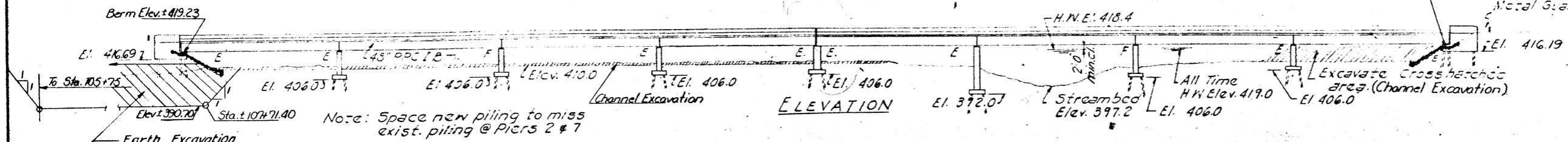

Note: Space new piling to miss exist. piling @ Piers 2 & 7

Earth Excavation  
 Replace with Porous Granular Embankment to natural ground or 2' above water elevation at time of replacement, whichever ever is higher.

WATERWAY INFORMATION

Drainage Area	205 Sq Miles
Design Discharge (50 yr)	24058 c.f.s.
Existing Opening (below 50 yr H.W.E.)	6600 Sq.Ft.
Required Opening (below 50 yr H.W.E.)	5800 Sq.Ft.
Proposed Opening (below 50 yr H.W.E.)	5800 Sq.Ft.
Creepage Head for design flood	0.8'

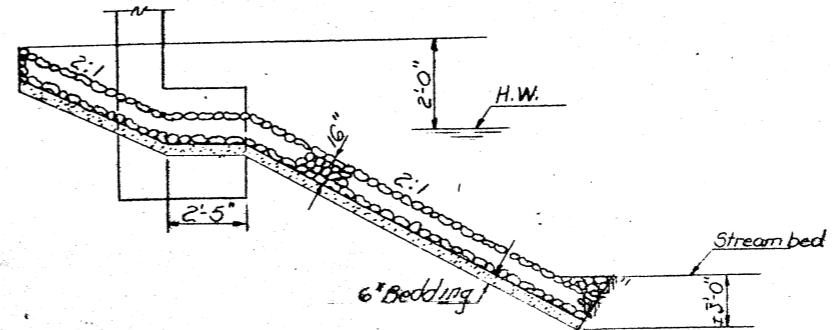
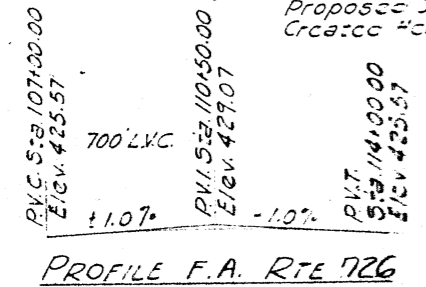

SEC. THRU STONE RIP RAP SLOPEWALL  
 (Billed with Road Plans)

TOTAL BILL OF MATERIAL

Item	Unit	Super	Sub	Total
Precast Prestressed Concrete I Beams (48")	Lin. Ft.	3202		3202
Class X Concrete	Cu. Yd.	746.9	622.0	1368.9
Reinforcement Bars	Pound	70230	31780	102,030
Reinforcement Bars (Epoxy Coated)	Pound	103,780		103,780
Neoprene Expansion Joint (6')	Lin. Ft.	34		34
Neoprene Expansion Joint (26')	Lin. Ft.	69		69
Steel Pile HP10x42	Lin. Ft.		6213	6213
Test Pile Steel HP10x42	Each		3	3
Name Plates	Each	1		1
Removal of Existing Structures	Each			1
Protective Coat	Sq. Yd.	2812	26	2838
Floor Drains	Each	26		26
Structure Excavation	Cu. Yd.		66	66
Channel Excavation	Cu. Yd.		3780	3780
Earth Excavation*	Cu. Yd.		8475	8475
Porous Granular Embankment	Cu. Yd.		7782	7782
Cofferdam Excavation	Cu. Yd.		590	590
Cofferdam (Pier #1)	Each		1	1
Cofferdam (Pier #2)	Each		1	1
Cofferdam (Pier #3)	Each		1	1
Cofferdam (Pier #4)	Each		1	1
Cofferdam (Pier #5)	Each		1	1
Cofferdam (Pier #6)	Each		1	1
Cofferdam (Pier #7)	Each		1	1
Temporary Bridge Complete	Each			1

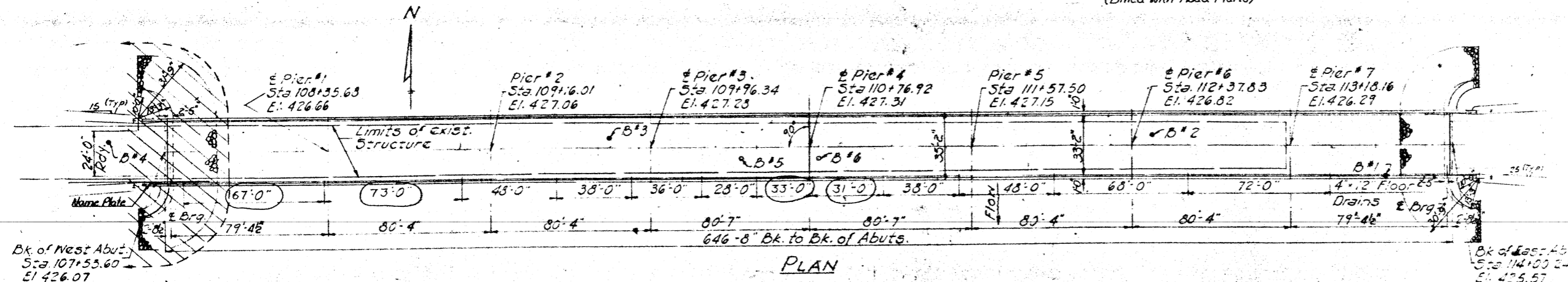

PLAN

STATION 110+76.92  
 BUILT BY  
 STATE OF ILLINOIS  
 F.A. RT. 726 SEC. 120 BR  
 F.A. PROJ. BR-F-726(4)  
 LOADING HS20  
 STR. NO.

NAME PLATE

Std. 2113  
 Structure Number to be supplied by District

DESIGN STRESSES

FIELD UNITS	PRECAST PRESTRESSED UNITS
$f_c = 3500$ psi.	$f_c = 6000$ psi.
$f_y = 60,000$ psi.	$f_s = 50,000$ psi.
	$f_s = 270,000$ psi. (2" strands)
	$f_s = 189,000$ psi. (1 1/2" strands)

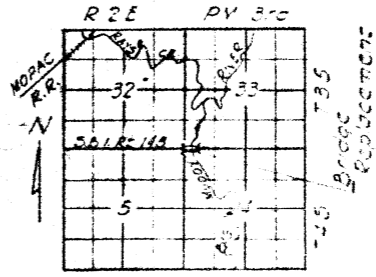

LOCATION SKETCH

DESIGNED	DAU KRULL
CHECKED	
DRAWN	
CHECKED	

March 27, 1979  
 EXAMINED  
 PASSED  
 APPROVED

Design Specifications 1977 AASHTO and 1978 Interim Specifications.

DESIGN LOADINGS HS 20-44

Included in Mainline Quantity  
 GENERAL PLAN AND ELEVATION  
 F.A. ROUTE 726 OVER BIG MOODY RIVER  
 F.A. ROUTE 726 SECTION 120 BR  
 JEFFERSON COUNTY  
 STATION 110+76.92

Bench Mark #3 Collected on Bent #15 So Side of Exst. Bridge  
 Right Sta 118+13.75 Elev 419.92  
 Exst. Structure Built as 5.5' Rte 148 Sec 120 B  
 Sta 111+80 in 1931 Contractor shall remove existing  
 structure after completion of detour.  
 No Salvage. Exst. Structure No. 041-0037  
 Existing Structure is one 100' span Truss and fifteen I Beam  
 approach spans at 143'-6". Truss and approach spans are  
 24'-8" out to out.

STATE OF ILLINOIS  
 DEPARTMENT OF TRANSPORTATION

ROUTE NO.	SECTION	COUNTY	TOTAL SHEETS	SHEET NO.
726	120 BR	Jefferson	37	8

SHEET NO. 1  
21 SHEETS

GENERAL NOTES

See Proposal for Boring Data.  
 All structural steel shall be shop painted with two coats of basic lead silico chromate paint.  
 Layout of Stone Rip Rap Walls may be varied in the field to suit ground conditions as directed by the Engineer.  
 The Contractor shall drive 3 Steel HP10x42 test piles, one each in a permanent location at each abutment and pier 4 as directed by the Engineer before ordering the remainder of piles.  
 The embankment configuration shown shall be the minimum embankment that must be constructed prior to construction of the abutments.  
 Reinforcement bars shall conform to the requirements of AASHTO M31 or M53 Grade 60.

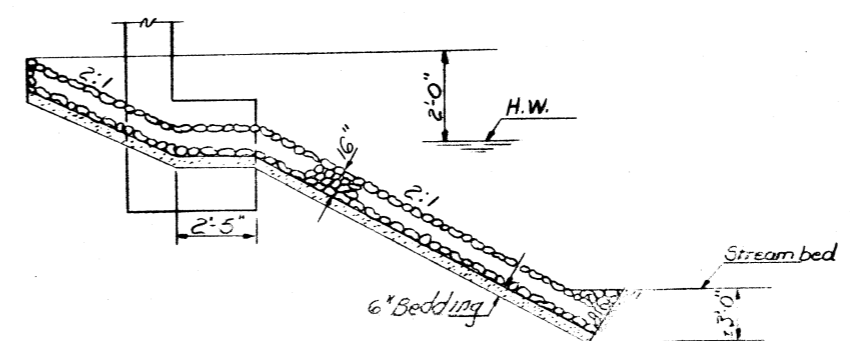
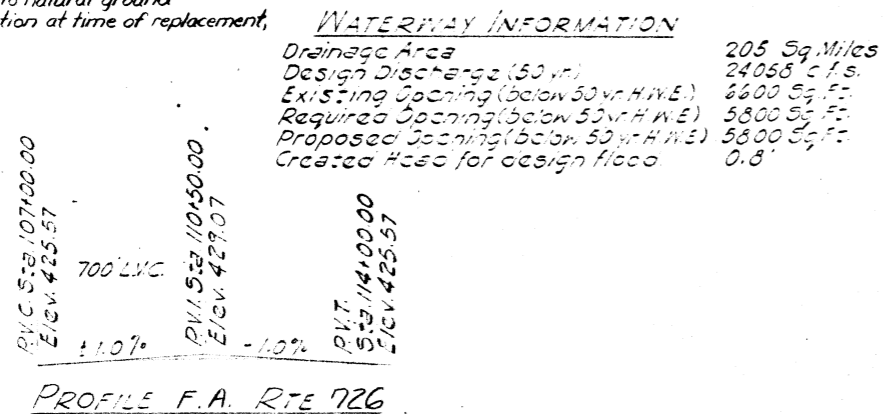
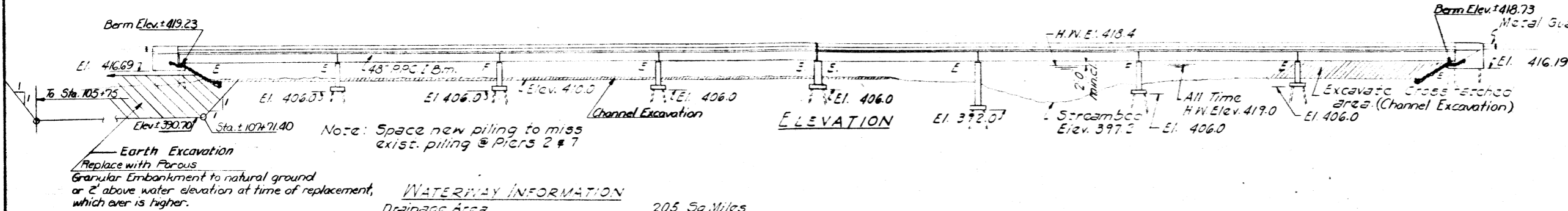

SEC. THRU STONE RIP RAP SLOPEWALL  
 (Based with Road Plans)

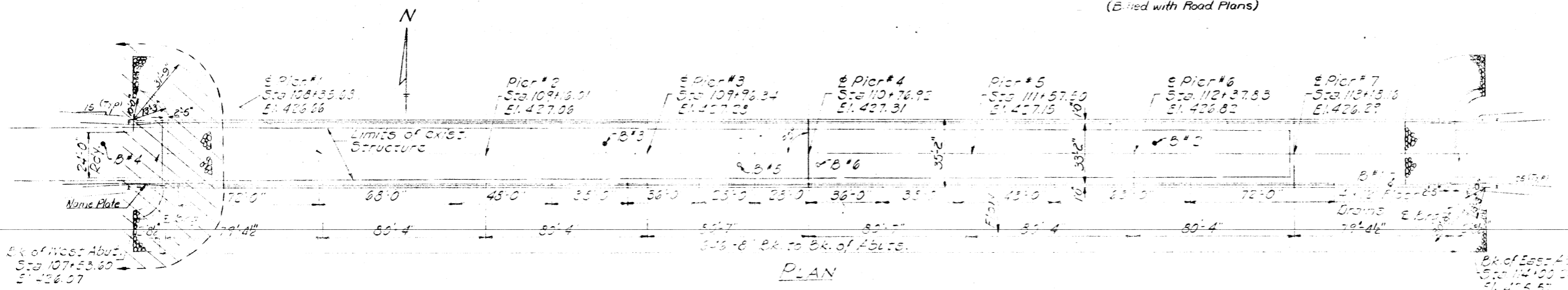

TOTAL BILL OF MATERIAL

Item	Unit	Super	Sub	Total
Precast Prestressed Concrete I Beams (48")	Lin. Ft.	3202		3202
Class X Concrete	Cu. Yd.	746.9	622.0	1368.9
Reinforcement Bars	Pound	70250	31760	102010
Reinforcement Bars (Epoxy Coated)	Pound	103790		103790
Neoprene Expansion Joint (62")	Lin. Ft.	34		34
Neoprene Expansion Joint (24")	Lin. Ft.	69		69
Steel Pile HP10x42	Lin. Ft.		6213	6213
Test Pile Steel HP10x42	Each		3	3
Name Plates	Each	1		1
Removal of Existing Structures	Each		1	1
Protective Coat	Sq. Yd.	2812	26	2838
Floor Drains	Each	26		26
Structure Excavation	Cu. Yd.		66	66
Channel Excavation	Cu. Ft.		3780	3780
Earth Excavation*	Cu. Yd.		8475	8475
Porous Granular Embankment	Cu. Yd.		7752	7752
Cofferdam Excavation	Cu. Yd.		530	530
Cofferdam (Pier #1)	Each		1	1
Cofferdam (Pier #2)	Each		1	1
Cofferdam (Pier #3)	Each		1	1
Cofferdam (Pier #4)	Each		1	1
Cofferdam (Pier #5)	Each		1	1
Cofferdam (Pier #6)	Each		1	1
Cofferdam (Pier #7)	Each		1	1
Temporary Bridge Complete	Each		1	1

DESIGNED	DAU K200
CHECKED	
DRAWN	
CHECKED	

EXAMINED  
 PASSED  
 APPROVED

NAME PLATE  
 Std. 2113  
 Structure Number to be supplied by District

DESIGN STRESSSES

FIELD JOINTS	PRECAST PRESTRESSED JOINTS
f <sub>c</sub> = 3000 psi	f <sub>c</sub> = 4000 psi
f <sub>s</sub> = 60000 psi	f <sub>s</sub> = 50000 psi
f <sub>s</sub> = 100000 psi (16" strands)	f <sub>s</sub> = 100000 psi (16" strands)

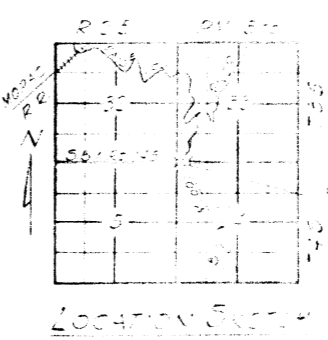

GENERAL PLAN AND ELEVATION  
 FA. ROUTE 726 SEC. 120 BR. JEFFERSON COUNTY  
 STATION 110+76.92

13 inches each side  
Sealed in town or street  
222 5/8" dia. pipe  
4 1/2" x 1/2" dia. pipe

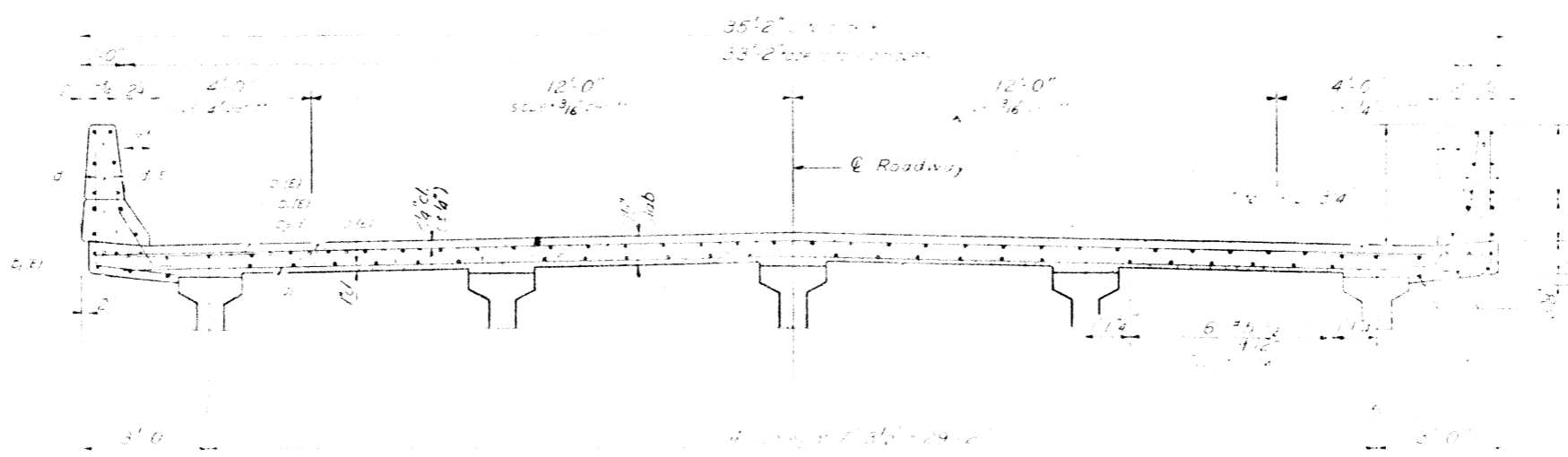
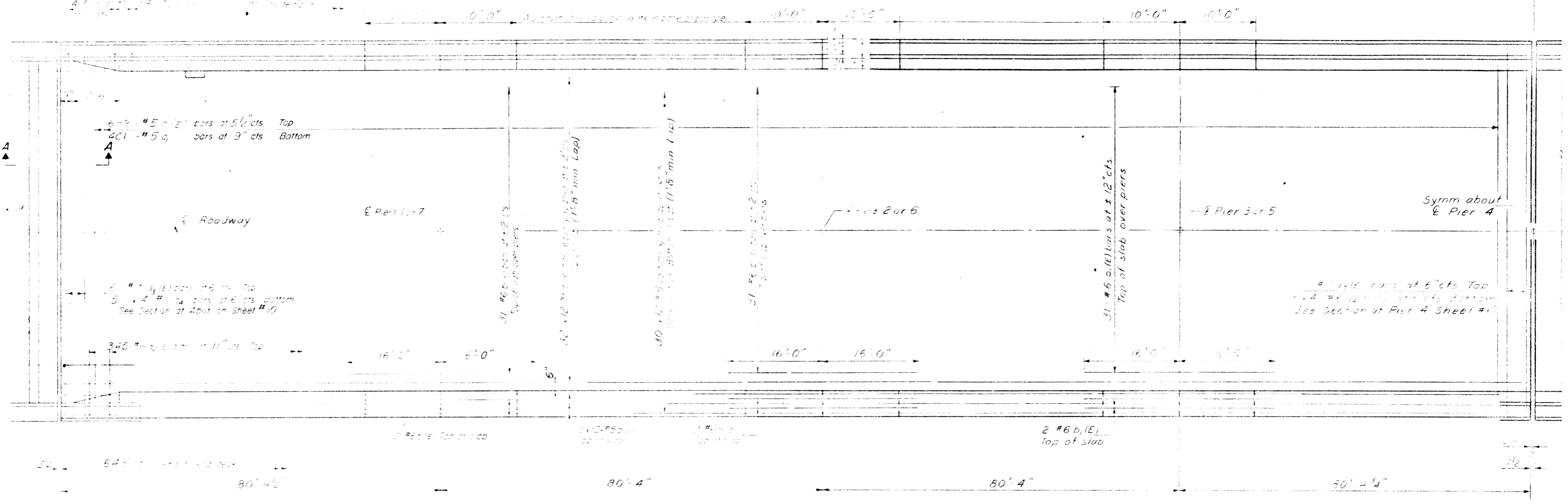

Notes:  
 1. Reinforcement #5 for 12" dia. pipe and 18" dia. pipe.  
 2. See sheet # 0 for Section of Abutments and Piers.  
 3. Reinforcement #6 for 12" dia. pipe and 18" dia. pipe.  
 4. Reinforcement #4 for 6" dia. pipe and 8" dia. pipe.

March 27 1939  
 C. E. ...

SUPERSTRUCTURE  
 FA RT 106 SEC 1 FOR  
 JEFFERSON COUNTY  
 STA. 110+76.92

STATE OF ILLINOIS  
DEPARTMENT OF TRANSPORTATION

ROUTE NO.	SECTION	COUNTY	POST MILE	SHEET NO.	SHEET NO.
726	120BR	Jefferson	37	9	21 SHEETS
FED. ROAD DIST. NO. 1					

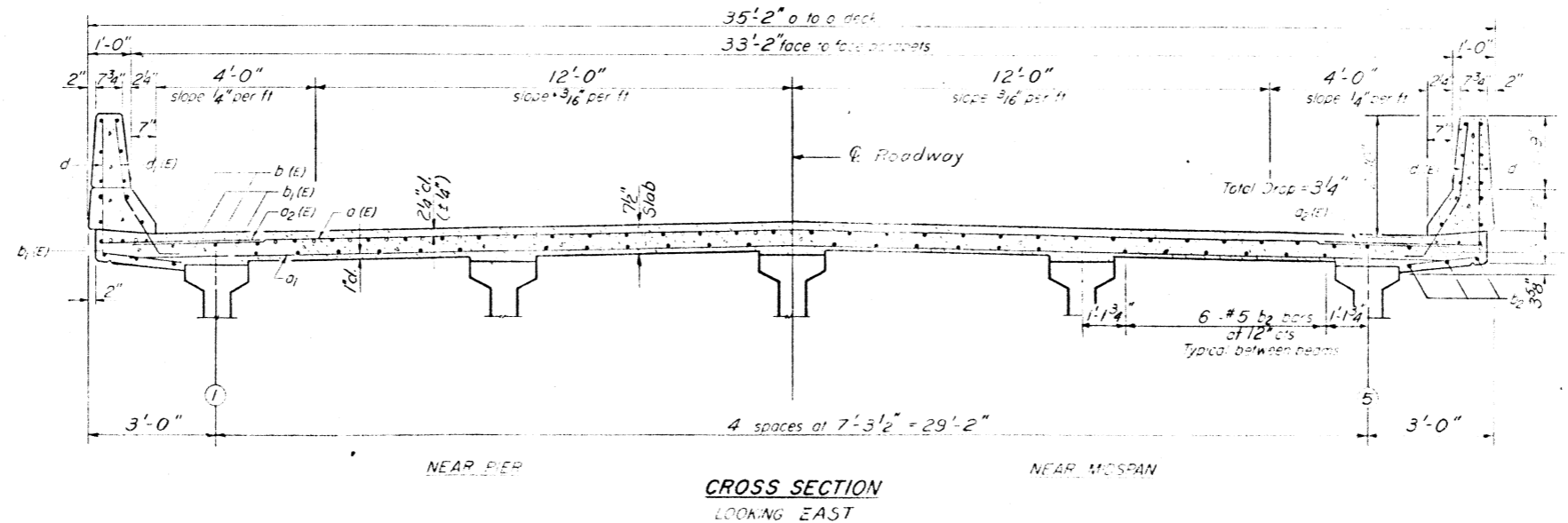
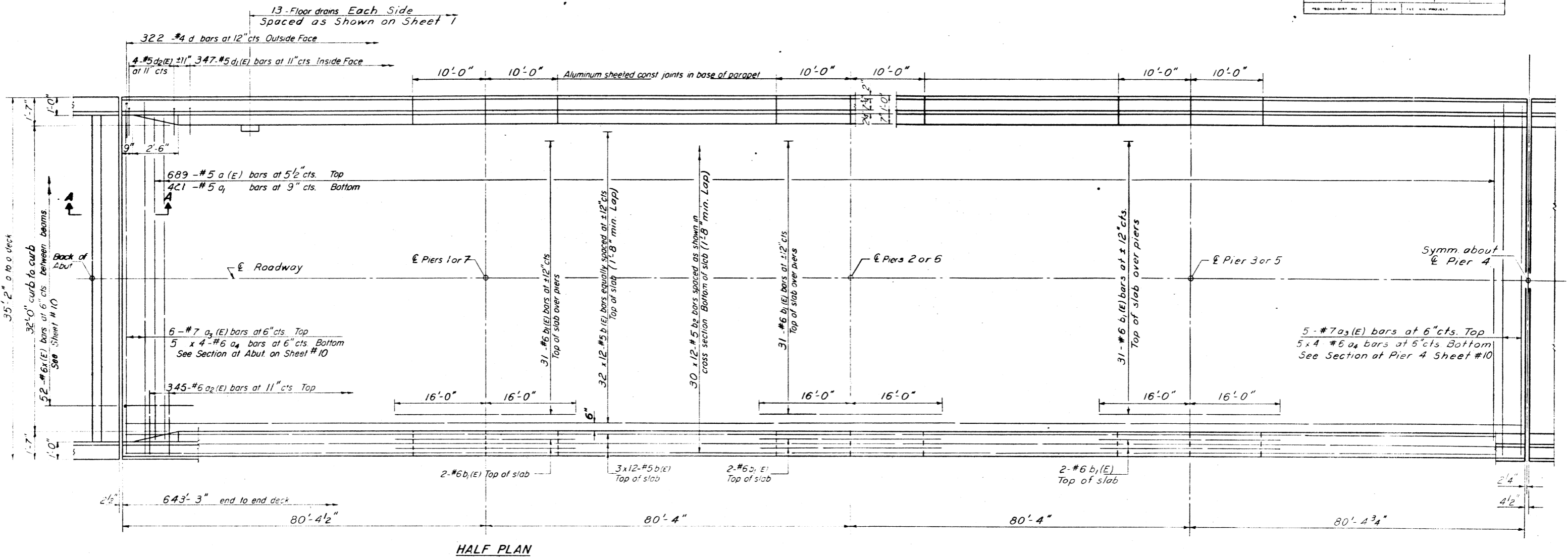

NOTES:  
See sheet #5 for Bill of Material and Parapet Details.  
See sheet #10 for Sections at Abutments and Piers.  
Reinforcement bars designated (E) shall be epoxy coated. See special provisions.  
Piers indicated thus: 20" x 3 #6 etc. indicates 20 inches of bars with 3 lengths per line.

DESIGNED: JAU KRULL  
CHECKED: J. M. BRADY  
DRAWN: P. P. SUMMER  
CHECKED: J. J.  
EXAMINED: *March 27 1979*  
PASSED:  
APPROVED:

SUPERSTRUCTURE  
F.A. RT. 726 SEC 120BR  
JEFFERSON COUNTY  
STA. 110+76.92

STATE OF ILLINOIS  
DEPARTMENT OF TRANSPORTATION

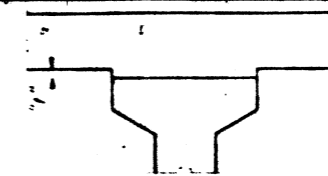
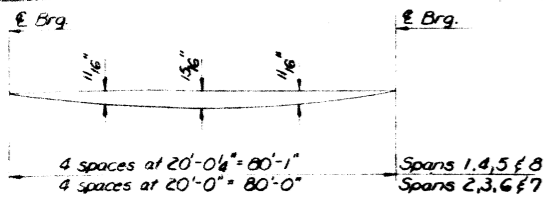

To determine "y" after all precast prestressed beams have been erected, elevations of the top flanges of the beams shall be taken at intervals shown below. Their elevations subtracted algebraically from the "Theoretical Grade Elevations Adjusted for Dead Load Deflections" shown below, minus slab thickness, equals the fillet heights "y". A positive value of "y" equals the fillet height above the top of the beam. A negative value of "y", not to exceed 2", equals the embedment of the beam above the theoretical bottom of slab elevation.

FILLET HEIGHTS

DEAD LOAD DEFLECTION DIAGRAM

(Typical for all Spans except as shown.)  
(Includes weight of concrete slab only)  
Note: The above deflections are not to be used in the field if the engineer is working from the grade elevations adjusted for dead load deflections as shown below.

BEAM #1

Location	Station	Offset	Theoretical Grade Elevations	Theoretical Grade Elevations Adjusted For Dead Load Deflection
£ Brg. West Abut.	10756.310	-14.583	425.847	425.847
A	10766.310	-14.533	425.529	425.958
B	10776.310	-14.583	426.009	426.066
C	10786.310	-14.583	426.085	426.155
D	10796.310	-14.583	426.159	426.238
E	10806.310	-14.583	426.230	426.298
F	10816.310	-14.583	426.299	426.352
G	10826.310	-14.583	426.364	426.388
West £ Brg. Pier 1	10834.727	-14.583	426.417	426.417
East £ Brg. Pier 1	10836.643	-14.583	426.428	426.428
H	10846.643	-14.583	426.488	426.517
I	10856.643	-14.583	426.545	426.602
J	10866.643	-14.583	426.598	426.667
K	10876.643	-14.583	426.649	426.729
L	10886.643	-14.583	426.699	426.765
M	10896.643	-14.583	426.743	426.797
N	10906.643	-14.583	426.795	426.810
West £ Brg. Pier 2	10915.352	-14.583	426.820	426.820
East £ Brg. Pier 2	10916.685	-14.583	426.825	426.825
O	10926.685	-14.583	426.862	426.891
P	10936.685	-14.583	426.895	426.953
Q	10946.685	-14.583	426.926	426.995
R	10956.685	-14.583	426.959	427.034
S	10966.685	-14.583	426.980	427.047
T	10976.685	-14.583	427.002	427.056
U	10986.685	-14.583	427.021	427.047
West £ Brg. Pier 3	10995.393	-14.583	427.036	427.036
East £ Brg. Pier 3	10997.310	-14.583	427.039	427.039
V	11007.310	-14.583	427.053	427.082
W	11017.310	-14.583	427.064	427.121
X	11027.310	-14.583	427.071	427.141
Y	11037.310	-14.583	427.076	427.155
Z	11047.310	-14.583	427.079	427.146
AA	11057.310	-14.583	427.078	427.131
BB	11067.310	-14.583	427.074	427.099
West £ Brg. Pier 4	11075.143	-14.583	427.069	427.069
East £ Brg. Pier 4	11078.143	-14.583	427.067	427.067
CC	11088.143	-14.583	427.058	427.037
DD	11098.143	-14.583	427.045	427.103
EE	11108.143	-14.583	427.030	427.130
FF	11118.143	-14.583	427.012	427.091
GG	11128.143	-14.583	426.992	427.059
HH	11138.143	-14.583	426.969	427.021
II	11148.143	-14.583	426.941	426.966
West £ Brg. Pier 5	11156.560	-14.583	426.917	426.917
East £ Brg. Pier 5	11158.477	-14.583	426.911	426.911
JJ	11168.477	-14.583	426.879	426.927
KK	11178.477	-14.583	426.843	426.900
LL	11188.477	-14.583	426.805	426.874
MM	11198.477	-14.583	426.764	426.843
NN	11208.477	-14.583	426.727	426.807
OO	11218.477	-14.583	426.683	426.727
PP	11228.477	-14.583	426.624	426.649
West £ Brg. Pier 6	11237.185	-14.583	426.578	426.578

BEAM #1 CONTINUED

Location	Station	Offset	Theoretical Grade Elevations	Theoretical Grade Elevations Adjusted For Dead Load Deflection
East £ Brg. Pier 6	11238.518	-14.583	426.571	426.571
QQ	11248.518	-14.583	426.516	426.545
RR	11258.518	-14.583	426.458	426.515
SS	11268.518	-14.583	426.397	426.466
TT	11278.518	-14.583	426.333	426.412
UU	11288.518	-14.583	426.266	426.334
VV	11298.518	-14.583	426.196	426.251
WW	11308.518	-14.583	426.124	426.149
West £ Brg. Pier 7	11317.227	-14.583	426.059	426.059
East £ Brg. Pier 7	11319.143	-14.583	426.044	426.044
XX	11329.143	-14.583	425.966	425.995
YY	11339.143	-14.583	425.884	425.942
ZZ	11349.143	-14.583	425.800	425.869
AAA	11359.143	-14.583	425.713	425.792
BBB	11369.143	-14.583	425.624	425.691
CCC	11379.143	-14.583	425.531	425.585
DDD	11389.143	-14.583	425.436	425.460
£ Brg. East Abut.	11397.560	-14.583	425.353	425.353

BEAM #2 CONTINUED

Location	Station	Offset	Theoretical Grade Elevations	Theoretical Grade Elevations Adjusted For Dead Load Deflection
East £ Brg. Pier 4	11078.143	-7.292	427.195	427.195
CC	11088.143	-7.292	427.185	427.214
DD	11098.143	-7.292	427.173	427.230
EE	11108.143	-7.292	427.158	427.227
FF	11118.143	-7.292	427.140	427.219
GG	11128.143	-7.292	427.119	427.186
HH	11138.143	-7.292	427.095	427.149
II	11148.143	-7.292	427.068	427.093
West £ Brg. Pier 5	11156.560	-7.292	427.044	427.044
East £ Brg. Pier 5	11158.477	-7.292	427.038	427.038
JJ	11168.477	-7.292	427.006	427.034
KK	11178.477	-7.292	426.970	427.028
LL	11188.477	-7.292	426.932	427.001
MM	11198.477	-7.292	426.891	426.970
NN	11208.477	-7.292	426.847	426.915
OO	11218.477	-7.292	426.801	426.855
PP	11228.477	-7.292	426.751	426.776
West £ Brg. Pier 6	11237.185	-7.292	426.706	426.706
East £ Brg. Pier 6	11238.518	-7.292	426.698	426.698
QQ	11248.518	-7.292	426.643	426.672
RR	11258.518	-7.292	426.585	426.642
SS	11268.518	-7.292	426.524	426.593
TT	11278.518	-7.292	426.460	426.539
UU	11288.518	-7.292	426.393	426.461
VV	11298.518	-7.292	426.324	426.378
WW	11308.518	-7.292	426.251	426.277
West £ Brg. Pier 7	11317.227	-7.292	426.186	426.186
East £ Brg. Pier 7	11319.143	-7.292	426.171	426.171
XX	11329.143	-7.292	426.093	426.122
YY	11339.143	-7.292	426.012	426.069
ZZ	11349.143	-7.292	425.928	425.997
AAA	11359.143	-7.292	425.841	425.920
BBB	11369.143	-7.292	425.751	425.818
CCC	11379.143	-7.292	425.658	425.712
DDD	11389.143	-7.292	425.563	425.587
£ Brg. East Abut.	11397.560	-7.292	425.480	425.480

BEAM #3 AND £ ROADWAY CONTINUED

Location	Station	Offset	Theoretical Grade Elevations	Theoretical Grade Elevations Adjusted For Dead Load Deflection
East £ Brg. Pier 2	10916.685	0.000	427.066	427.066
O	10926.685	0.000	427.103	427.132
P	10936.685	0.000	427.137	427.194
Q	10946.685	0.000	427.168	427.237
R	10956.685	0.000	427.196	427.275
S	10966.685	0.000	427.221	427.288
T	10976.685	0.000	427.243	427.237
U	10986.685	0.000	427.263	427.288
West £ Brg. Pier 3	10995.393	0.000	427.277	427.277
East £ Brg. Pier 3	10997.310	0.000	427.280	427.280
V	11007.310	0.000	427.294	427.323
W	11017.310	0.000	427.305	427.362
X	11027.310	0.000	427.313	427.382
Y	11037.310	0.000	427.318	427.357
Z	11047.310	0.000	427.320	427.387
AA	11057.310	0.000	427.314	427.373
BB	11067.310	0.000	427.316	427.340
West £ Brg. Pier 4	11075.727	0.000	427.311	427.311
East £ Brg. Pier 4	11078.143	0.000	427.309	427.309
CC	11088.143	0.000	427.299	427.328
DD	11098.143	0.000	427.287	427.344
EE	11108.143	0.000	427.272	427.341
FF	11118.143	0.000	427.254	427.333
GG	11128.143	0.000	427.233	427.300
HH	11138.143	0.000	427.209	427.262
II	11148.143	0.000	427.182	427.227
West £ Brg. Pier 5	11156.560	0.000	427.158	427.158
East £ Brg. Pier 5	11158.477	0.000	427.152	427.152
JJ	11168.477	0.000	427.117	427.148
KK	11178.477	0.000	427.084	427.141
LL	11188.477	0.000	427.045	427.115
MM	11198.477	0.000	427.005	427.084
NN	11208.477	0.000	426.961	427.029
OO	11218.477	0.000	426.915	426.959
PP	11228.477	0.000	426.865	426.910
West £ Brg. Pier 6	11237.185	0.000	426.819	426.819
East £ Brg. Pier 6	11238.518	0.000	426.812	426.812
QQ	11248.518	0.000	426.757	426.786
RR	11258.518	0.000	426.699	426.746
SS	11268.518	0.000	426.638	426.707
TT	11278.518	0.000	426.574	426.653
UU	11288.518	0.000	426.507	426.595
VV	11298.518	0.000	426.438	426.492
WW	11308.518	0.000	426.365	426.390
West £ Brg. Pier 7	11317.227	0.000	426.310	426.310
East £ Brg. Pier 7	11319.143	0.000	426.295	426.285
XX	11329.143	0.000	426.237	426.236
YY	11339.143	0.000	426.176	426.183
ZZ	11349.143	0.000	426.112	426.111
AAA	11359.143	0.000	426.045	426.044
BBB	11369.143	0.000	425.972	425.971
CCC	11379.143	0.000	425.897	425.896
DDD	11389.143	0.000	425.826	425.825
£ Brg. East Abut.	11397.560	0.000	425.594	425.594

BEAM #2

Location	Station	Offset	Theoretical Grade Elevations	Theoretical Grade Elevations Adjusted For Dead Load Deflection
£ Brg. West Abut.	10756.310</			



STATE OF ILLINOIS  
DEPARTMENT OF TRANSPORTATION

BEAM #4

BEAM #4 CONTINUED

BEAM #5

BEAM #5 CONTINUED

Location	Station	Offset	Theoretical Grade Elevations	Theoretical Grade Elevations Adjusted For Dead Load Deflection
E. Brg. West Abut.	10756.310	7.292	425.974	425.974
A B C D E F G	10766.310	7.292	426.056	426.085
	10776.310	7.292	426.136	426.193
	10786.310	7.292	426.213	426.282
	10796.310	7.292	426.287	426.366
	10806.310	7.292	426.358	426.425
	10816.310	7.292	426.426	426.479
	10826.310	7.292	426.491	426.516
West E. Brg. Pier 1	10834.727	7.292	426.544	426.544
East E. Brg. Pier 1	10836.643	7.292	426.556	426.556
H I J K L M N	10846.643	7.292	426.615	426.644
	10856.643	7.292	426.672	426.729
	10866.643	7.292	426.726	426.795
	10876.643	7.292	426.777	426.856
	10886.643	7.292	426.825	426.892
	10896.643	7.292	426.870	426.924
	10906.643	7.292	426.912	426.938
West E. Brg. Pier 2	10915.352	7.292	426.947	426.947
East E. Brg. Pier 2	10916.685	7.292	426.952	426.952
O P Q R S T U	10926.685	7.292	426.939	427.018
	10936.685	7.292	427.023	427.000
	10946.685	7.292	427.054	427.123
	10956.685	7.292	427.082	427.161
	10966.685	7.292	427.107	427.174
	10976.685	7.292	427.129	427.183
	10986.685	7.292	427.149	427.174
West E. Brg. Pier 3	10995.393	7.292	427.163	427.163
East E. Brg. Pier 3	10997.310	7.292	427.166	427.166
V W X Y Z AA BB	11007.310	7.292	427.180	427.209
	11017.310	7.292	427.191	427.243
	11027.310	7.292	427.199	427.268
	11037.310	7.292	427.204	427.283
	11047.310	7.292	427.206	427.273
	11057.310	7.292	427.205	427.259
	11067.310	7.292	427.202	427.226
West E. Brg. Pier 4	11075.727	7.292	427.197	427.197

Location	Station	Offset	Theoretical Grade Elevations	Theoretical Grade Elevations Adjusted For Dead Load Deflection
East E. Brg. Pier 4	11078.143	7.292	427.195	427.195
CC DD EE FF GG HH II	11088.143	7.292	427.185	427.214
	11098.143	7.292	427.173	427.230
	11108.143	7.292	427.158	427.227
	11118.143	7.292	427.140	427.219
	11128.143	7.292	427.119	427.186
	11138.143	7.292	427.095	427.149
	11148.143	7.292	427.068	427.093
West E. Brg. Pier 5	11156.560	7.292	427.044	427.044
East E. Brg. Pier 5	11158.477	7.292	427.038	427.038
JJ KK LL MM NN OO PP	11168.477	7.292	427.006	427.034
	11178.477	7.292	426.970	427.028
	11188.477	7.292	426.932	427.001
	11198.477	7.292	426.891	426.970
	11208.477	7.292	426.847	426.915
	11218.477	7.292	426.801	426.855
	11228.477	7.292	426.751	426.776
West E. Brg. Pier 6	11237.185	7.292	426.706	426.706
East E. Brg. Pier 6	11238.518	7.292	426.698	426.698
QQ RR SS TT UU VV WW	11248.518	7.292	426.643	426.672
	11258.518	7.292	426.585	426.642
	11268.518	7.292	426.524	426.593
	11278.518	7.292	426.460	426.539
	11288.518	7.292	426.461	426.461
	11298.518	7.292	426.324	426.378
	11308.518	7.292	426.251	426.277
West E. Brg. Pier 7	11317.227	7.292	426.186	426.186
East E. Brg. Pier 7	11319.143	7.292	426.171	426.171
XX YY ZZ AAA BBB CCC DDD	11329.143	7.292	426.093	426.122
	11339.143	7.292	426.012	426.069
	11349.143	7.292	425.928	425.957
	11359.143	7.292	425.841	425.920
	11369.143	7.292	425.751	425.818
	11379.143	7.292	425.658	425.712
	11389.143	7.292	425.563	425.587
E. Brg. East Abut.	11397.560	7.292	425.480	425.480

Location	Station	Offset	Theoretical Grade Elevations	Theoretical Grade Elevations Adjusted For Dead Load Deflection
E. Brg. West Abut.	10756.310	14.583	425.847	425.847
A B C D E F G	10766.310	14.583	425.929	425.958
	10776.310	14.583	426.009	426.066
	10786.310	14.583	426.085	426.155
	10796.310	14.583	426.159	426.238
	10806.310	14.583	426.230	426.298
	10816.310	14.583	426.299	426.352
	10826.310	14.583	426.364	426.388
West E. Brg. Pier 1	10834.727	14.583	426.417	426.417
East E. Brg. Pier 1	10836.643	14.583	426.428	426.428
H I J K L M N	10846.643	14.583	426.488	426.517
	10856.643	14.583	426.545	426.602
	10866.643	14.583	426.598	426.657
	10876.643	14.583	426.649	426.729
	10886.643	14.583	426.698	426.765
	10896.643	14.583	426.743	426.797
	10906.643	14.583	426.785	426.810
West E. Brg. Pier 2	10915.352	14.583	426.820	426.820
East E. Brg. Pier 2	10916.685	14.583	426.825	426.825
O P Q R S T U	10926.685	14.583	426.862	426.891
	10936.685	14.583	426.895	426.933
	10946.685	14.583	426.926	426.995
	10956.685	14.583	426.954	427.034
	10966.685	14.583	426.980	427.047
	10976.685	14.583	427.002	427.056
	10986.685	14.583	427.021	427.047
West E. Brg. Pier 3	10995.393	14.583	427.036	427.036
East E. Brg. Pier 3	10997.310	14.583	427.039	427.039
V W X Y Z AA BB	11007.310	14.583	427.053	427.082
	11017.310	14.583	427.063	427.121
	11027.310	14.583	427.071	427.141
	11037.310	14.583	427.076	427.195
	11047.310	14.583	427.079	427.146
	11057.310	14.583	427.073	427.131
	11067.310	14.583	427.074	427.099
West E. Brg. Pier 4	11075.727	14.583	427.069	427.069

Location	Station	Offset	Theoretical Grade Elevations	Theoretical Grade Elevations Adjusted For Dead Load Deflection
East E. Brg. Pier 4	11078.143	14.583	427.067	427.067
CC DD EE FF GG HH II	11088.143	14.583	427.058	427.087
	11098.143	14.583	427.046	427.103
	11108.143	14.583	427.030	427.100
	11118.143	14.583	427.012	427.091
	11128.143	14.583	426.992	427.059
	11138.143	14.583	426.968	427.021
	11148.143	14.583	426.941	426.966
West E. Brg. Pier 5	11156.560	14.583	426.917	426.917
East E. Brg. Pier 5	11158.477	14.583	426.911	426.911
JJ KK LL MM NN OO PP	11168.477	14.583	426.878	426.907
	11178.477	14.583	426.843	426.900
	11188.477	14.583	426.805	426.874
	11198.477	14.583	426.764	426.843
	11208.477	14.583	426.720	426.877
	11218.477	14.583	426.674	426.827
	11228.477	14.583	426.624	426.649
West E. Brg. Pier 6	11237.185	14.583	426.578	426.578
East E. Brg. Pier 6	11238.518	14.583	426.571	426.571
QQ RR SS TT UU VV WW	11248.518	14.583	426.516	426.545
	11258.518	14.583	426.458	426.515
	11268.518	14.583	426.397	426.466
	11278.518	14.583	426.333	426.412
	11288.518	14.583	426.266	426.334
	11298.518	14.583	426.196	426.251
	11308.518	14.583	426.124	426.149
West E. Brg. Pier 7	11317.227	14.583	426.059	426.059
East E. Brg. Pier 7	11319.143	14.583	426.054	426.044
XX YY ZZ AAA BBB CCC DDD	11329.143	14.583	425.976	425.955
	11339.143	14.583	425.894	425.942
	11349.143	14.583	425.800	425.866
	11359.143	14.583	425.713	425.742
	11369.143	14.583	425.624	425.641
	11379.143	14.583	425.531	425.549
	11389.143	14.583	425.436	425.450
E. Brg. East Abut.	11397.560	14.583	425.353	425.353

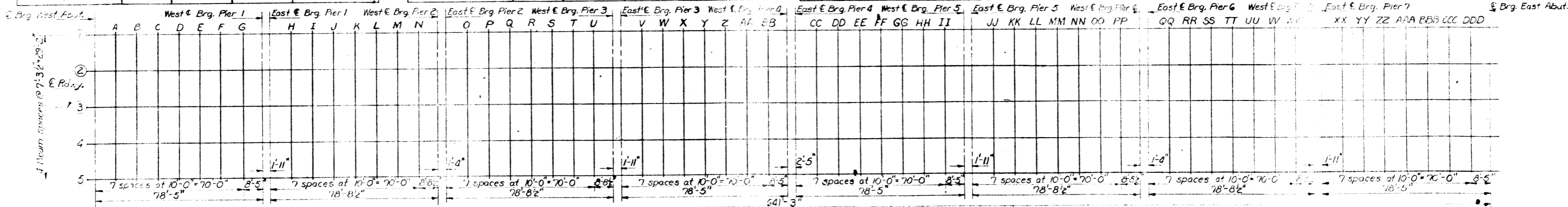

DAU KRULL  
 EXAMINED  
 PASSED  
 JRS  
 APR 22 1977  
 CARL E. KRULL

PLAN

TOP OF SLAB ELEVATIONS  
 FA. RT. 726 SEC. 120 BR  
 JEFFERSON COUNTY  
 STATION 110+76.92





STATE OF ILLINOIS  
DEPARTMENT OF TRANSPORTATION

ROUTE NO.	SECTION	COUNTY	TOTAL SHEETS	SHEET NO.	SHEET NO. 6 21 SHEETS
726	120BR	Jefferson	37	13	
FED. ROAD DIST. NO. 7		ILLINOIS	FED. AID PROJECT		

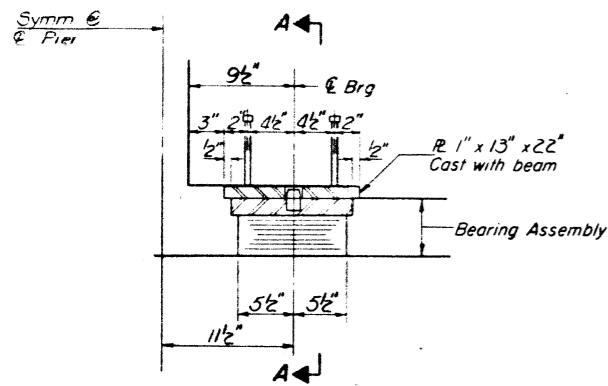

SECTION AT PIERS

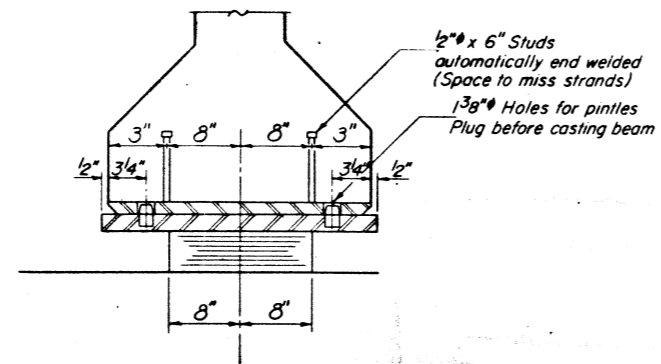

SECTION A-A

TYPE I ELASTOMERIC EXP. BRG.

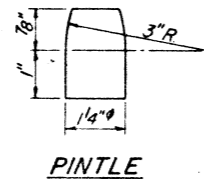
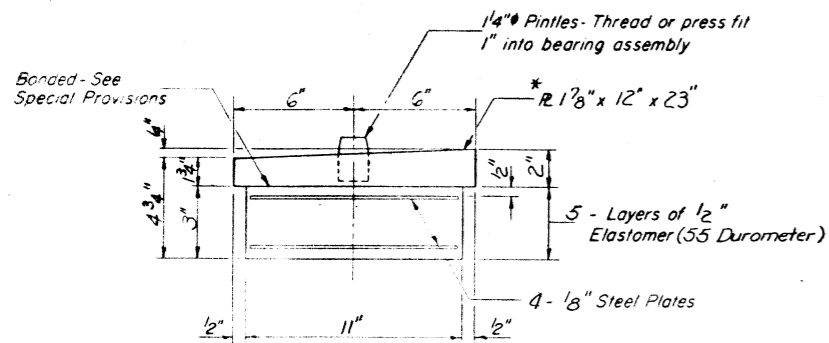

PINTLE

BEARING ASSEMBLY

\* Top Bearing Plate is tapered as shown. 1 3/4" Dimension shall be placed towards nearest abutment.

DESIGNED	DAV KRULL
CHECKED	SCOTT BECKETT
DRAWN	de Sutherland
CHECKED	SNZ

EXAMINED *Walt 27 1979*  
 PASSED  
 APPROVED  
 ENGINEER OF DESIGN  
 DIRECTOR OF HIGHWAYS

STATE OF ILLINOIS  
DEPARTMENT OF TRANSPORTATION

ROUTE NO.	SECTION	COUNTY	TOTAL SHEETS	SHEET NO.
726	120 BR	Jefferson	37	14
FED. ROAD DIST. NO.		ILLINOIS	FED. AID PROJECT	

SHEET NO. 7  
21 SHEETS

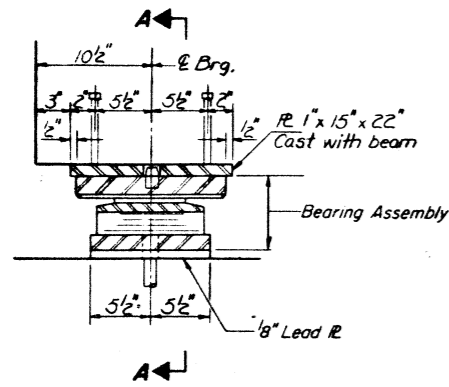

SECTION AT ABUTS. AND PIER 4

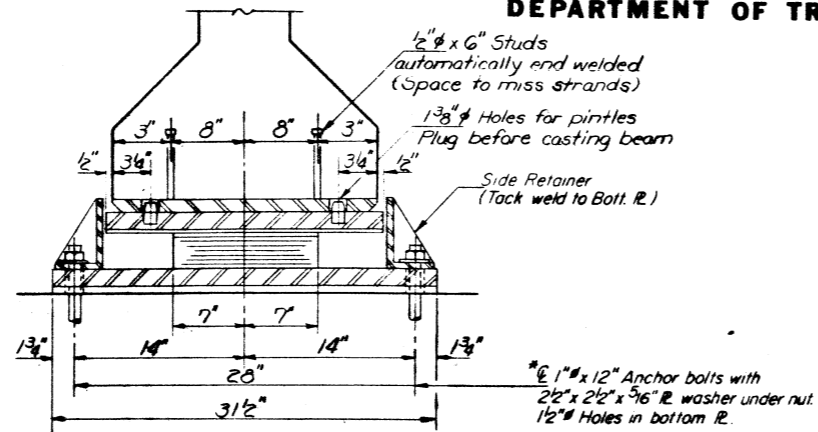

SECTION A-A

TYPE II TFE ELASTOMERIC EXP. BRG.

\*Note: After beams have been erected holes of expansion bearings shall be drilled and anchor bolts grouted in place.

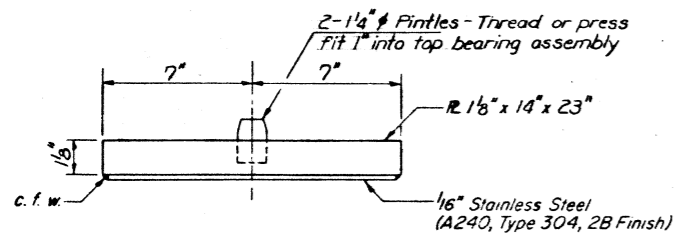

TOP BEARING ASSEMBLY

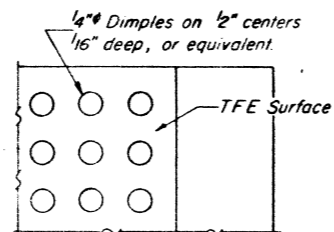

PLAN - TFE SURFACE

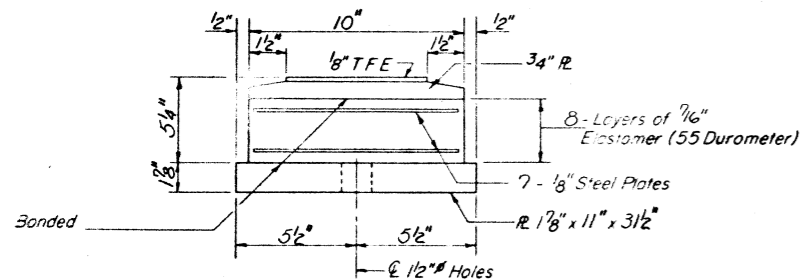

BOTTOM BEARING ASSEMBLY

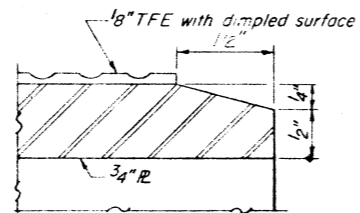

SECTION THRU TFE

Note: The 1/8" TFE sheet shall be bonded directly to the top steel plate with a two-component, medium viscosity epoxy resin, conforming to the requirements of the Federal Specification MMM-A-134, Type I. The bond agent shall be applied on the full area of the contact surfaces. Bonding of 1/8" TFE sheet during vulcanizing process will be permitted provided the process and method of adjusting assembly height is approved by the Engineer.

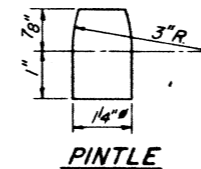

PINTLE

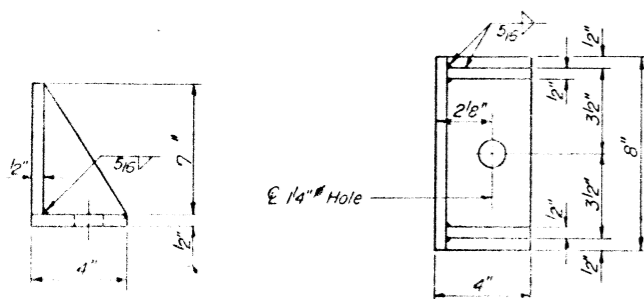

SIDE RETAINER

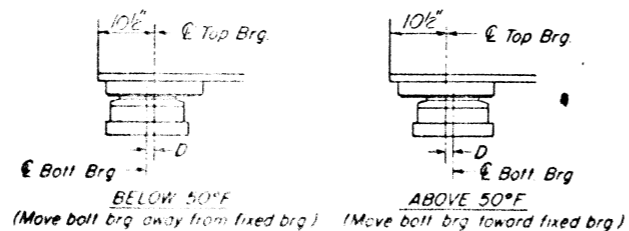

BELOW 50°F (Move bolt brg. away from fixed brg.)  
ABOVE 50°F (Move bolt brg. toward fixed brg.)  
**SETTING ANCHOR BOLTS AT EXP. BRG.**  
D = 1/8" per each 100' of expansion for every 15° temp. change from the normal temp. of 50°F

DESIGNED	DAN KRULL
CHECKED	EDWARD REYNOLDS
DRAWN	Joe Sutherland
CHECKED	TS

EXAMINED  
Mars 27 1979  
PASSED  
APPROVED  
ENGINEER OF RECORD  
DIRECTOR OF HIGHWAYS

ABUTMENTS AND PIER 4  
BEARING DETAILS  
FA. RT. 726 SEC. 120 BR  
JEFFERSON COUNTY  
STATION 110+70.92

STATE OF ILLINOIS  
DEPARTMENT OF TRANSPORTATION

PROJECT NO.	SECTION	COUNTY	TOTAL SHEETS	SHEET NO.	SHEET NO.
726	120BR	Jefferson	37	15	21 SHEETS
FED. ROAD DIST. NO. 7		BLANKING	FED. AID PROJECT		

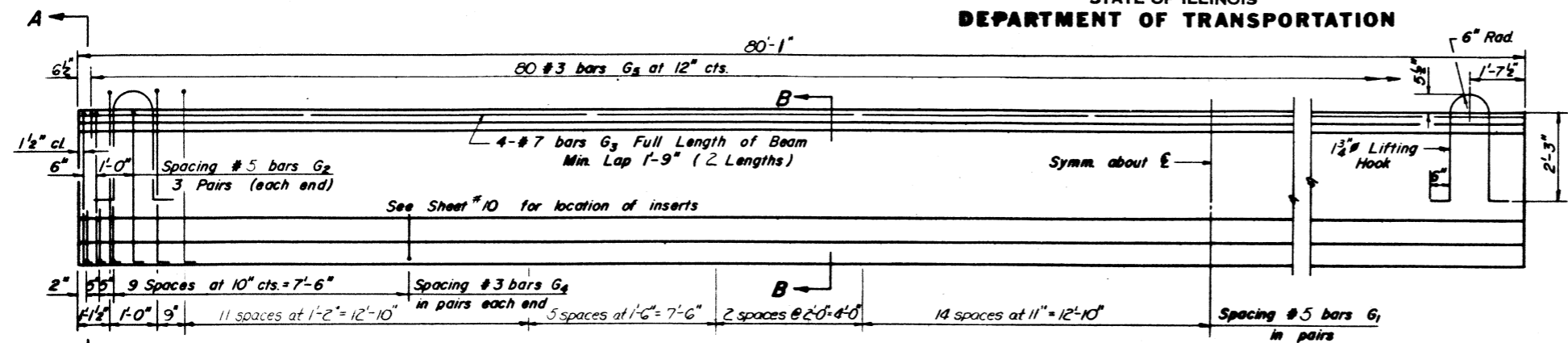

**ELEVATION OF BEAMS**  
Showing Reinforcement & Dimensions

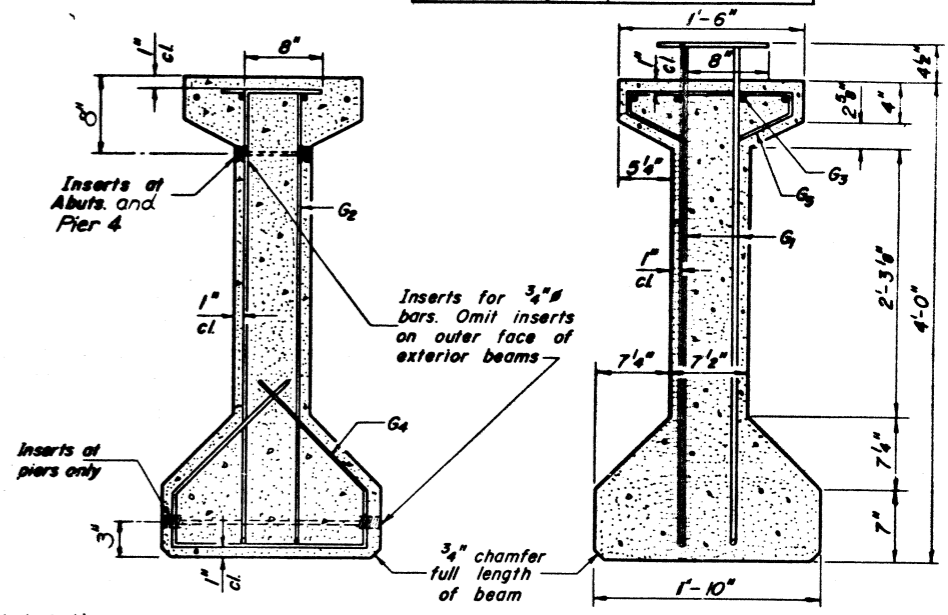

**SECTION A-A**

**SECTION B-B**

Cut 8 strands in bottom rows with a 12" projection at ends of all beams over piers. Shop bend.

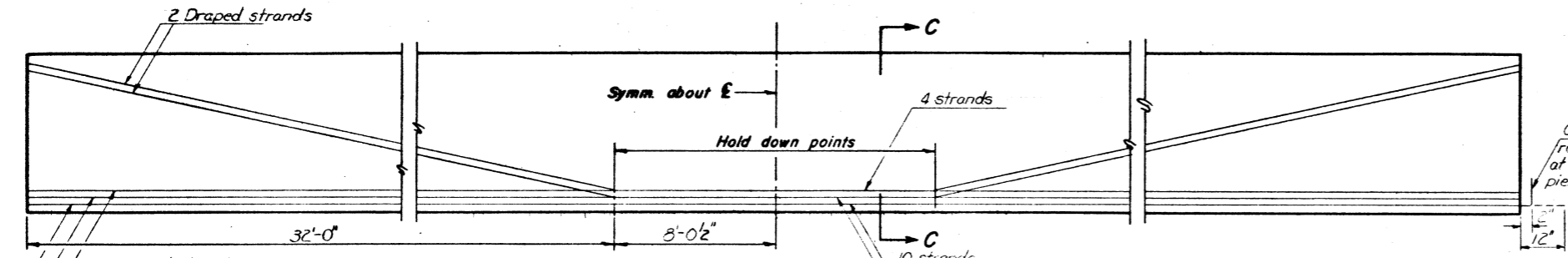

**ELEVATION OF BEAMS**  
Showing Prestressing Steel

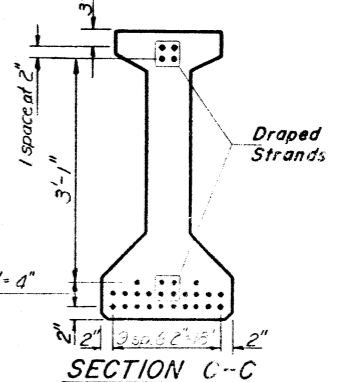

**SECTION C-C**

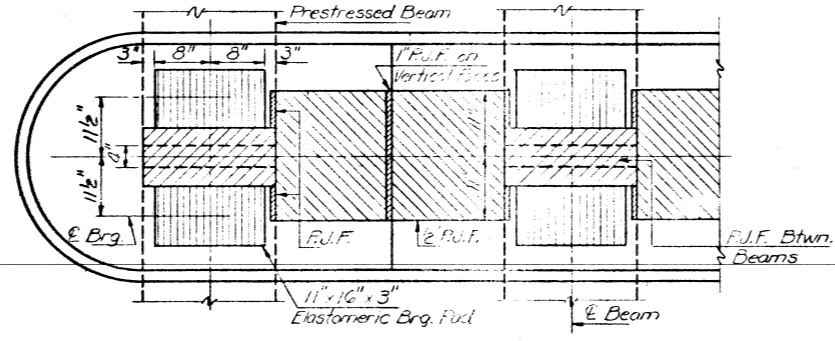

**EXPANSION PIERS**  
(Piers 1, 3, 5 & 7)

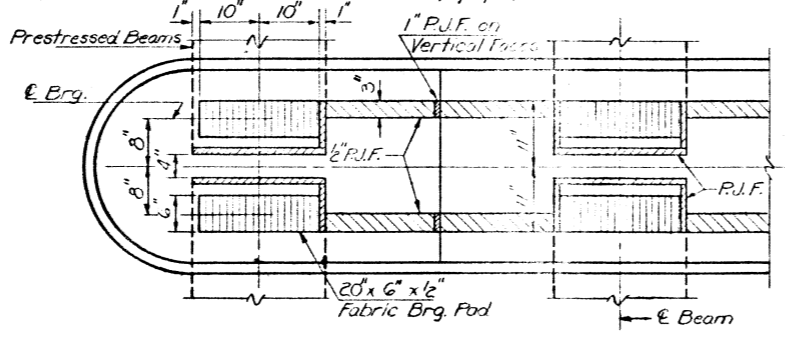

**FIXED PIER**  
(Piers 2 & 6)

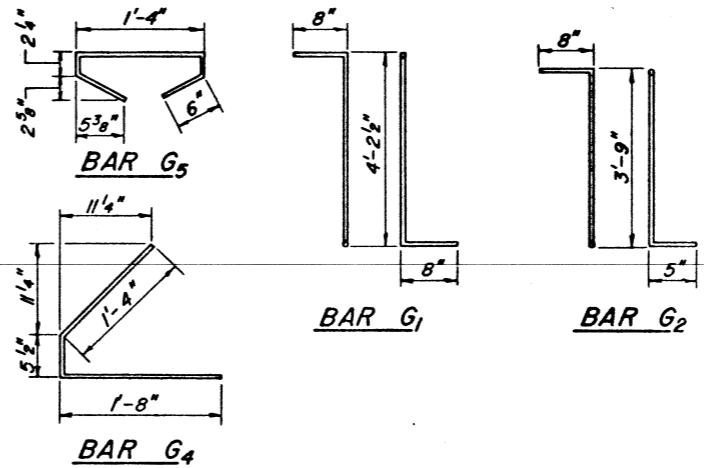

**\*BAR LIST**

Bar	No.	Size	Length	Shape
G1	140	#3	5'-6 1/2"	7L
G2	12	#3	4'-10"	7L
G3	8	#7	40'-9"	
G4	48	#3	3'-5 1/2"	∟
G5	80	#3	2'-8 1/2"	∩

\*For one beam only.

**BILL OF MATERIAL**

Item	Unit	Total
Furnishing & Erecting Precast Prestressed Concrete I-Beams, 48"	Lin. Ft.	1602

**NOTES**

All inserts and threaded rods for inserts, reinforcing and Prestressing Steel, and other items which are cast into the Precast Concrete I-Beams shall be included in the contract unit price per lineal foot of "Furnishing And Erecting Precast Prestressed Concrete I-Beams, 48 In."

Prestressing Steel shall have a nominal diameter of 1/2".  
Inserts for 3/4" threaded rods are to be two strut, coil type for interior I-Beams and single coil, flared loop type for exterior I-Beams.  
Steel for lifting hooks shall be non-deformed bars fy = 40,000 psi.

**BEAM DETAILS**  
SPANS 1, 4, 5 and 8  
FA. RT. 726 SEC. 120BR  
JEFFERSON COUNTY  
STATION 110-7692

DESIGNED	Jan 1974
CHECKED	
DRAWN	
CHECKED	

EXAMINED *March 19 74*  
PASSED  
APPROVED  
UNDER SECRETARY, CHIEF TRANSPORTATION ENGINEER

STATE OF ILLINOIS  
DEPARTMENT OF TRANSPORTATION

DESIGN NO.	SECTION	COUNTY	TOTAL SHEETS	SHEET NO.
726	120BR	Jefferson	37	16
SHEET NO. 9 21 SHEETS				

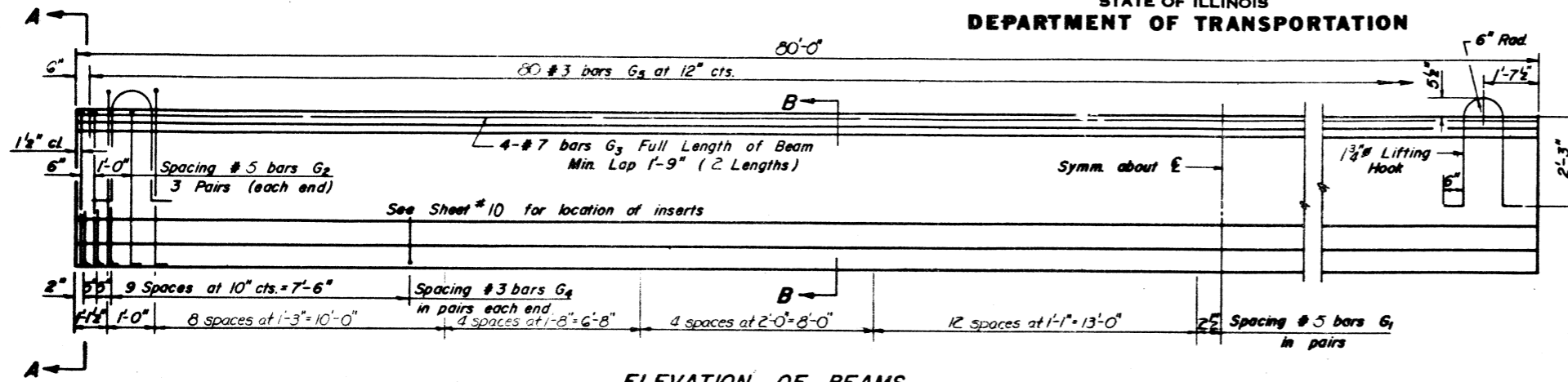

ELEVATION OF BEAMS  
Showing Reinforcement & Dimensions

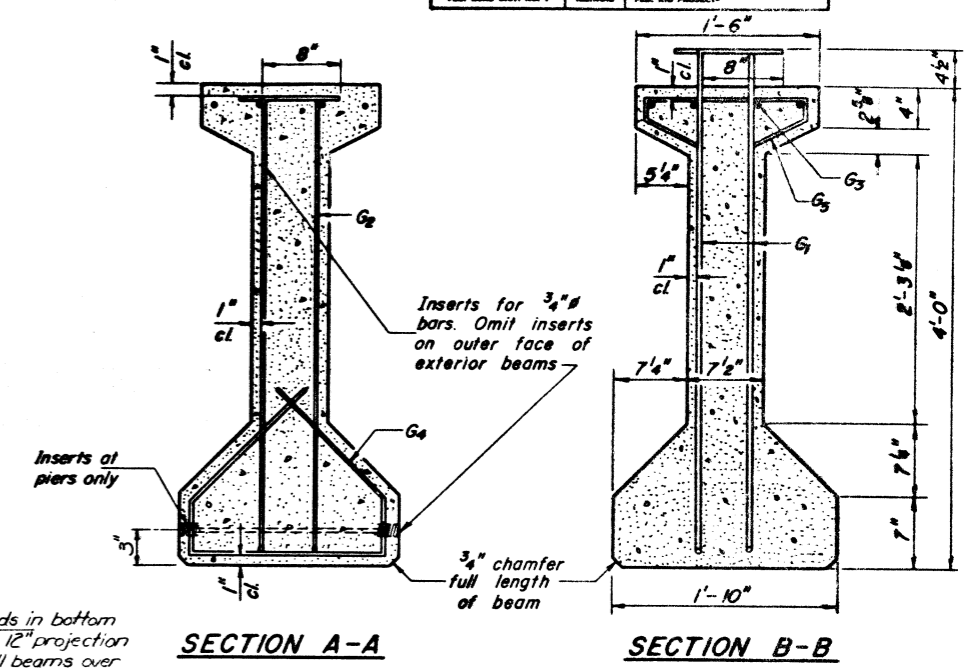
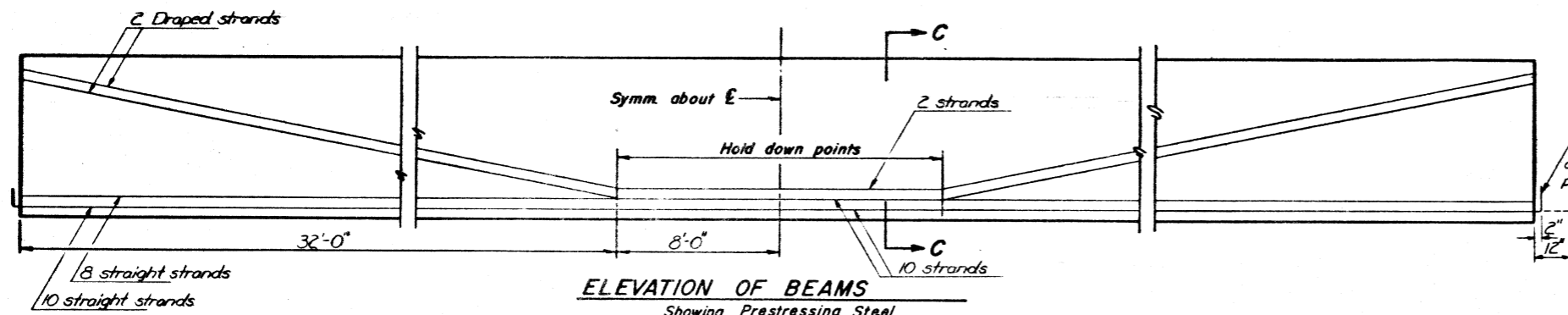

Cut 8 strands in bottom rows with a 12" projection at ends of all beams over piers. Shop bend. (Both ends)

SECTION A-A

SECTION B-B

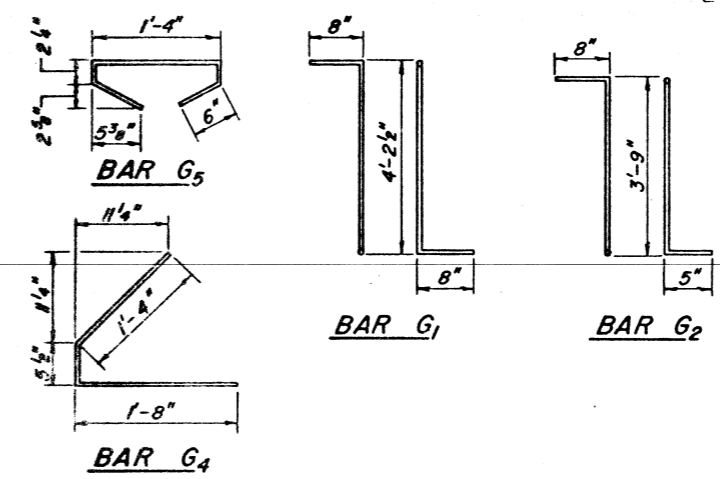
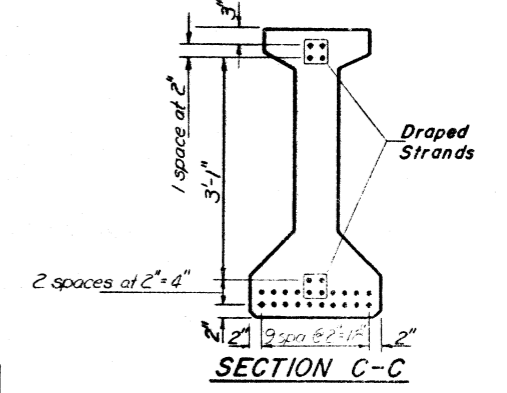

\*BAR LIST

Bar	No.	Size	Length	Shape
G <sub>1</sub>	120	#5	5'-6 1/2"	7L
G <sub>2</sub>	12	#6	4'-10"	7L
G <sub>3</sub>	8	#7	7'-0"	7L
G <sub>4</sub>	48	#3	3'-5 1/2"	L
G <sub>5</sub>	80	#3	2'-8 1/2"	U

\*For one beam only.

BILL OF MATERIAL

Item	Unit	Total
Furnishing & Erecting Precast Prestressed Concrete I-Beams, 48"	Lin. Ft.	1600

NOTES

All inserts and threaded rods for inserts, reinforcing and Prestressing Steel, and other items which are cast into the Precast Concrete I-Beams shall be included in the contract unit price per lineal foot of "Furnishing And Erecting Precast Prestressed Concrete I-Beams, 48 In."

Prestressing Steel shall have a nominal diameter of 1/2".  
Inserts for 3/4" threaded rods are to be two strut, coil type for interior I-Beams and single coil, flared loop type for exterior I-Beams.  
Steel for lifting hooks shall be non-deformed bars f<sub>y</sub> = 40,000 psi.

BEAM DETAILS  
SPANS 2, 3, 6 and 7  
F.A. RT 726 SEC. 120BR  
JEFFERSON COUNTY  
STATION 110+76.92

DESIGNED	JAC KULL	EXAMINED	March 21 1979 C. E. [Signature]
CHECKED	[Signature]	PASSED	[Signature]
DRAWN	[Signature]	APPROVED	[Signature]
CHECKED	RAB	UNDER SECRETARY, CHIEF TRANSPORTATION ENGINEER	

STATE OF ILLINOIS  
DEPARTMENT OF TRANSPORTATION

ROUTE NO.	SECTION	COUNTY	TOTAL SHEETS	SHEET NO.	SHEET NO. 10 21 SHEETS
726	120BR	Jefferson	37	17	
FED. ROAD DIST. NO. 1					

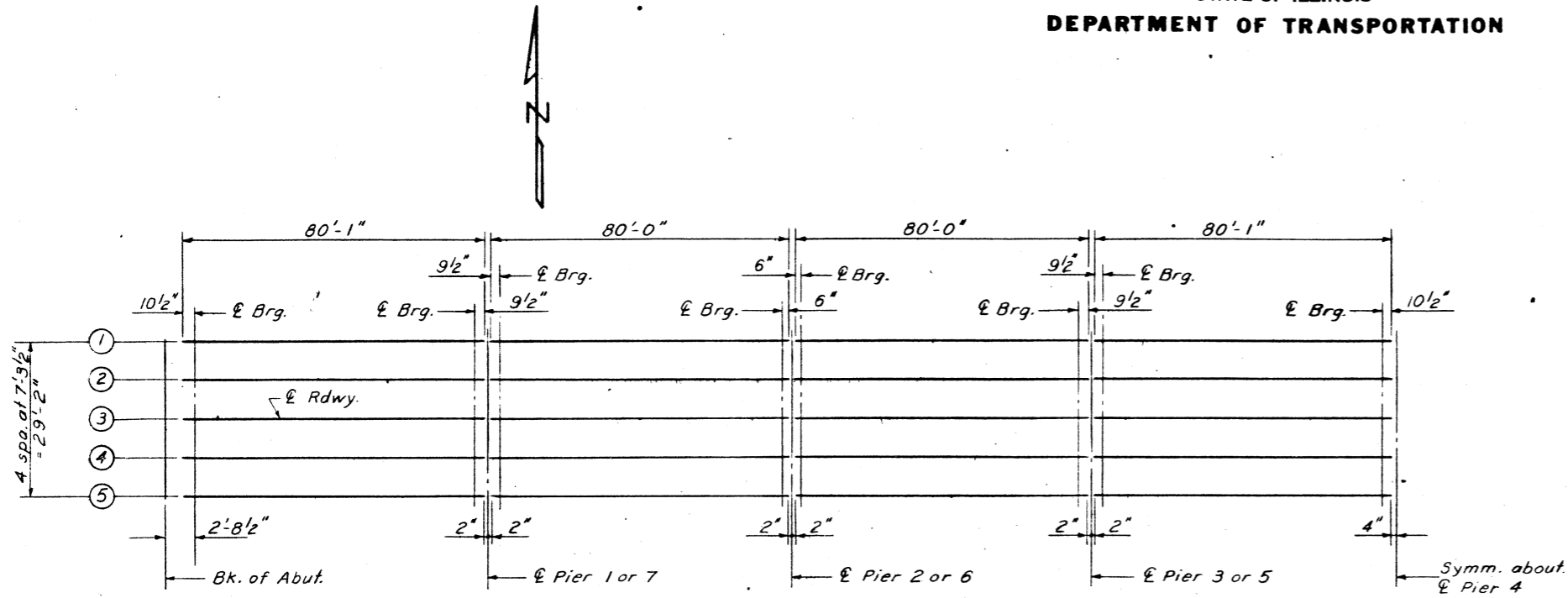

HALF FRAMING PLAN

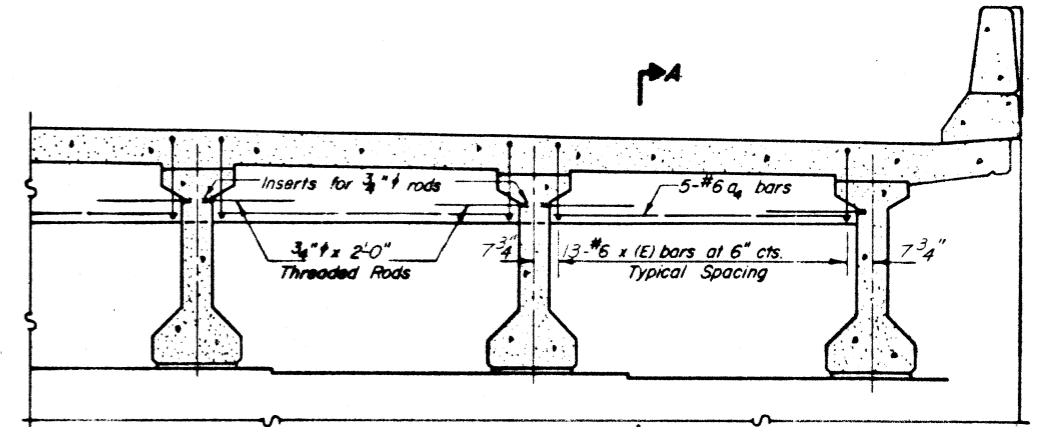

DIAPHRAGM AT ABUTMENTS  
AND PIER 4

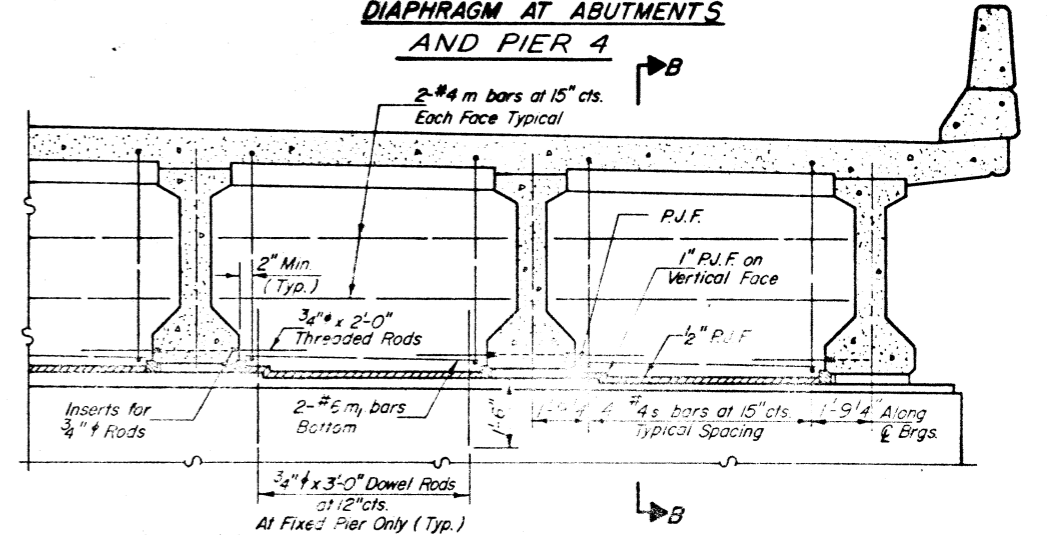

DIAPHRAGM AT PIERS  
1, 2, 3, 5, 6 & 7

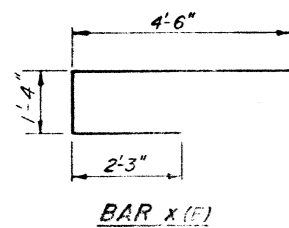

BAR X (E)

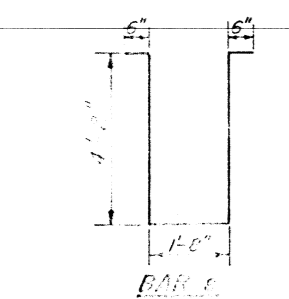

BAR Y

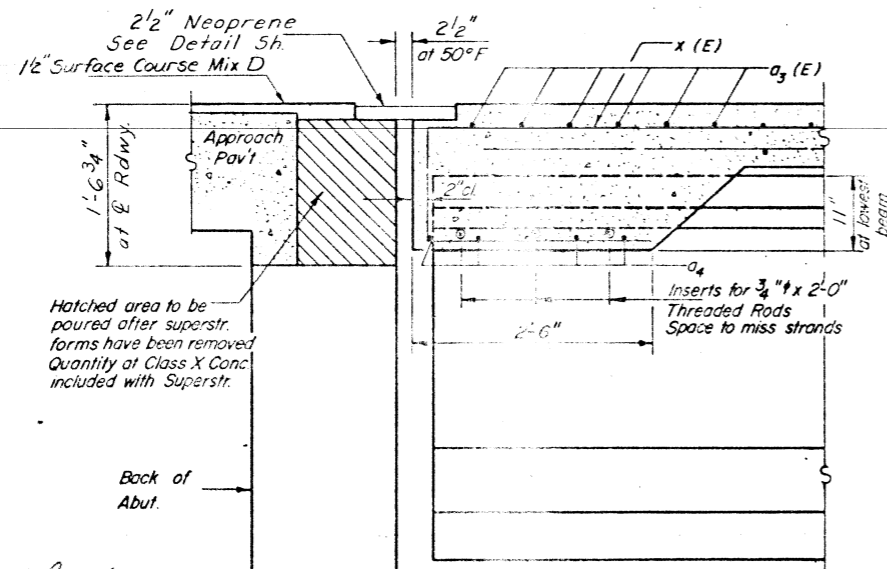

SECTION A-A  
AT ABUTMENT  
(at Rt 2 s)

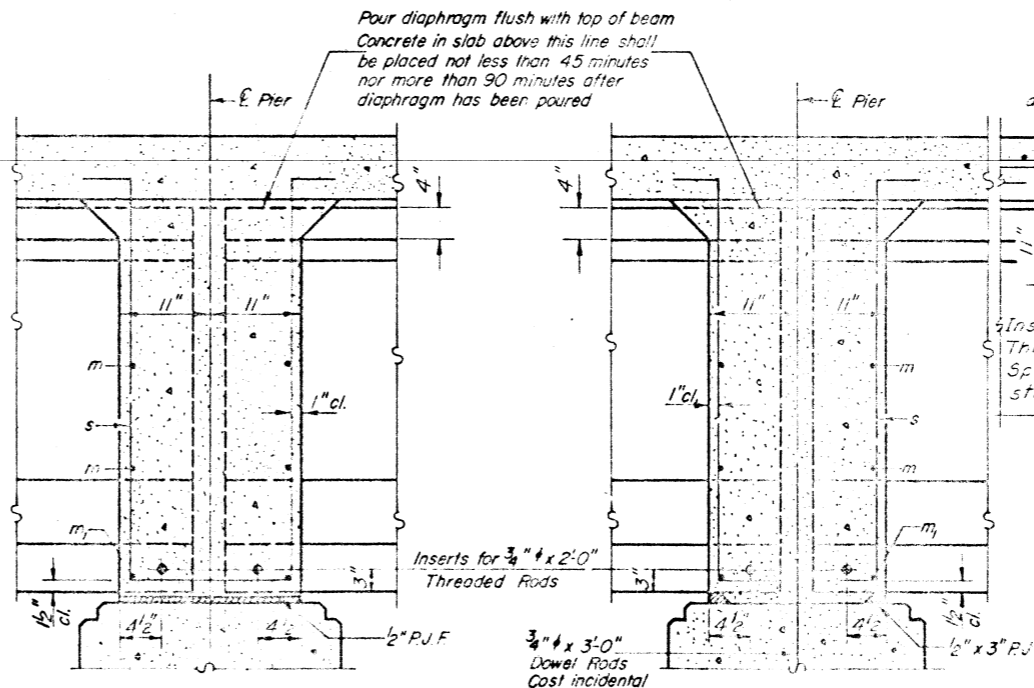

SECTION B-B  
AT PIER  
(Expansion)

SECTION B-B  
AT PIER  
(Fixed)

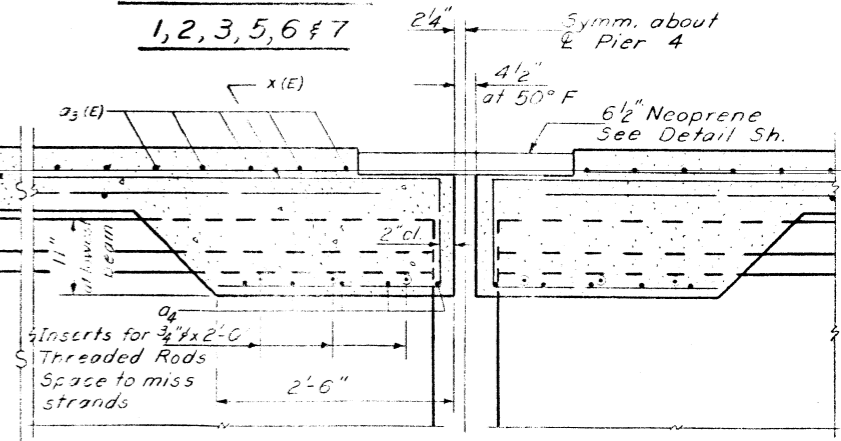

SECTION A-A  
AT PIER 4  
(at Rt 2 s)

NOTE: Reinforcement bars shown on this sheet are included in Bill of Material on sheet # 5

DESIGNED	...
CHECKED	...
DRAWN	R. P. Summer
CHECKED	...

March 27 1977  
EXAMINED  
PASSED  
APPROVED  
DIRECTOR OF HIGHWAYS

FRAMING PLAN  
FA. RT. 725 SEC. 120BR  
JEFFERSON COUNTY  
STA. 110+76.92

**ALTERNATE NEOPRENE EXPANSION JOINTS (2 1/2")**  
(See Special Provisions)

Model	Supplier	Blockout Dimensions
TRANSFLEX, MODEL 250 Use 5/8" x 6" Anchor Bolts.	General Tire Company	T = 2 1/8", A = 1 1/2", B = 4 1/4"
WABOFLEX, MODEL SR 2.5 Use 5/8" x 6" Anchor Bolts.	Watson Bowman Associates, Inc.	T = 2 1/8", A = 1 1/2", B = 4 1/4"
FEL-SPAN, MODEL T-30 Set joint seal 1 5/8" at 50°F.	Fel-Pro Building Products Inc.	T = 1 3/4", A = 2 1/4", B = 2 9/16"
WABO ELASTODAM, TYPE 300 Set joint seal 1 5/8" at 50°F.	Watson Bowman Associates, Inc.	T = 1 3/4", A = 2 1/4", B = 2 9/16"
WABO ALU-STRIP, TYPE III S300 Set joint seal 1 1/2" at 50°F. Permitted for 0° skew only.	Watson Bowman Associates, Inc.	T = 1 3/4", A = 1 5/8", B = 2 1/2"
LOW PROFILE ONFLEX-25 Set joint seal 1 1/2" at 50°F. Roadway bolt channel shall be filled with approved grout. Permitted for up to 50° skew.	Structural Accessories, Inc.	T = 1 3/4", A = 1 5/8", B = 2 1/8"

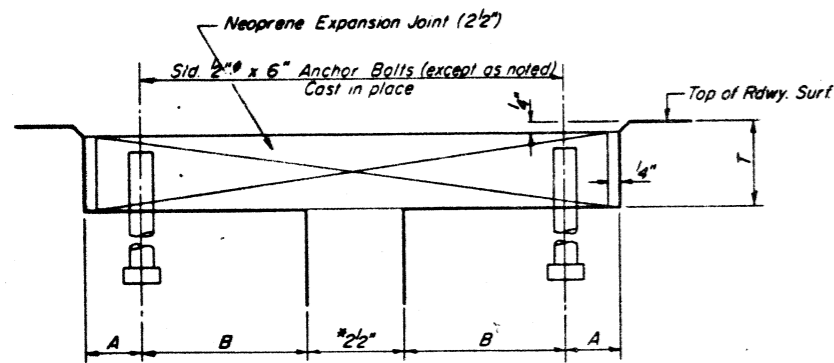

**CROSS SECTION**

\*At 50°F  
Dimensions are at right angles.

**NOTE:**  
Joint openings shall be adjusted in accordance with Article 503.07(c) of the Std Specs. when the deck is poured at an ambient temperature other than 50°F.

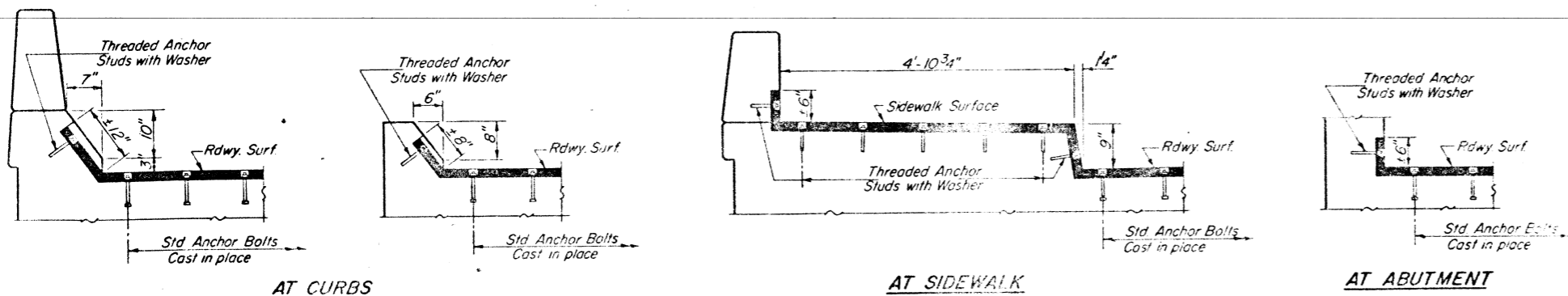

**TYPICAL END TREATMENTS**

DESIGNED	JAN KRULL
CHECKED	DAVID BRUNETTE
DRAWN	Joe Sutherland
CHECKED	P+5

March 27 1979  
EXAMINED *Carl E. Harman*  
PASSED  
APPROVED  
DIRECTOR OF HIGHWAYS

**ABUTMENTS**  
NEOPRENE EXPANSION JOINTS (2 1/2")  
FOR EXPANSION LENGTH OF DECK = 160 ft to 200 ft

F.A. RT. 726 SEC. 120 BR  
JEFFERSON COUNTY  
STATION 110+76.92

STATE OF ILLINOIS  
DEPARTMENT OF TRANSPORTATION

ROUTE NO.	SECTION	COUNTY	TOTAL SHEETS	SHEET NO.	SHEET NO. 12
726	120 BR	Jefferson	37	19	21 SHEETS
FED. ROAD DIST. NO. 7	ILLINOIS	FED. AID PROJ. ELY.			

**ALTERNATE NEOPRENE EXPANSION JOINTS (6 1/2")**

( See Special Provisions )

**Model**  
TRANSFLEX, MODEL 650

**Supplier**  
General Tire Company

**Blockout Dimensions**  
T = 3 1/4", A = 2 1/8", B = 9 7/8"

**WABOFLEX, MODEL SR 6.5**  
Use 3/4" x 6" Anchor Bolts

**Watson Bowman Associates, Inc.**

T = 3 1/4", A = 2 1/8", B = 9 7/8"

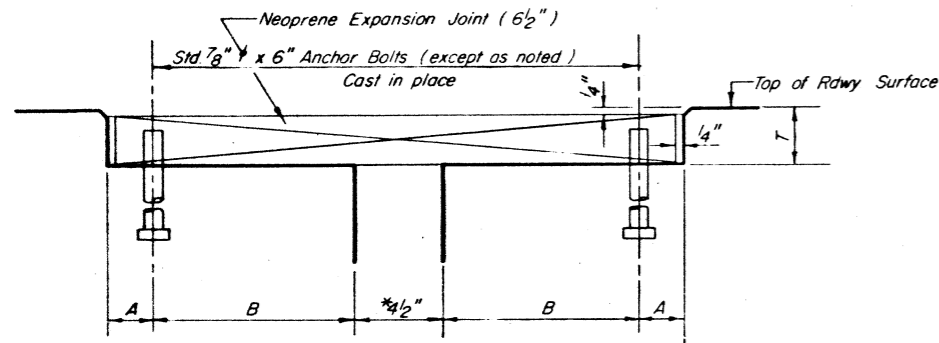

**CROSS SECTION**  
\*At 50° F  
Dimensions are at right angles.

**NOTE:**  
Joint openings shall be adjusted in accordance with Article 503.07 (c) of the Std. Spec's when the deck is poured at an ambient temperature other than 50° F.

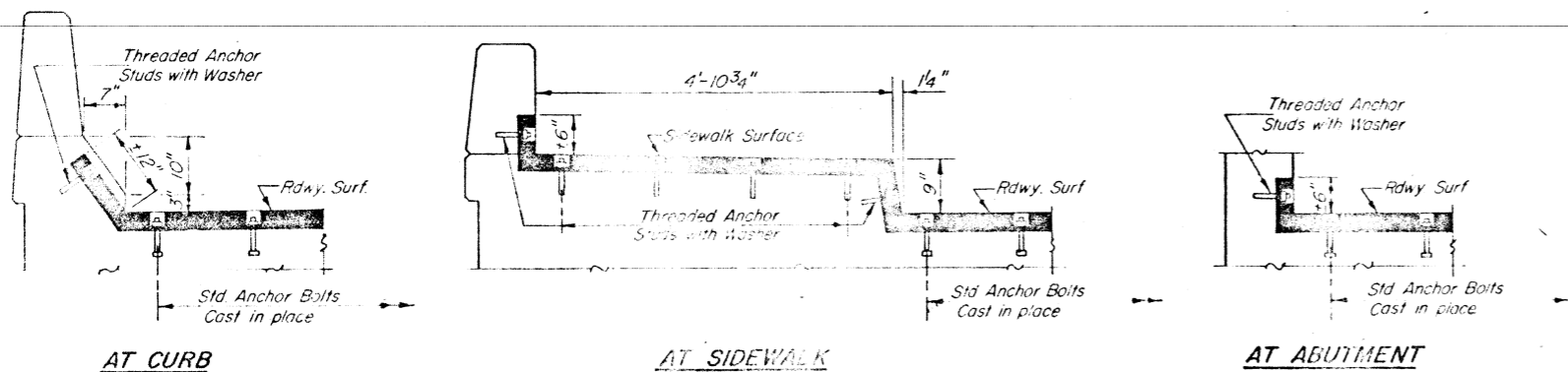

**TYPICAL END TREATMENTS**

DESIGNED: JAG KRULL  
CHECKED: JAG KRULL  
DRAWN: R. Sutherland  
CHECKED: JAG

EXAMINED: *March 22, 1979*  
PASSED: *Carl E. ...*  
APPROVED:

PIER 4

NEOPRENE EXPANSION JOINTS (6 1/2")  
FOR EXPANSION LENGTH OF DECK = 320 ft. to 520 ft.

F.A. RT. 726 SEC. 120 BR  
JEFFERSON COUNTY  
STATION 110+76.92



STATE OF ILLINOIS  
DEPARTMENT OF TRANSPORTATION

ROUTE NO.	SECTION	COUNTY	TOTAL SHEETS	SHEET NO.	SHEET NO. 13
74	120BR	Jefferson	37	20	21 SHEETS
FED. ROAD DIST. NO. 7					
ILLINOIS					
FED. AID PROGRAM					

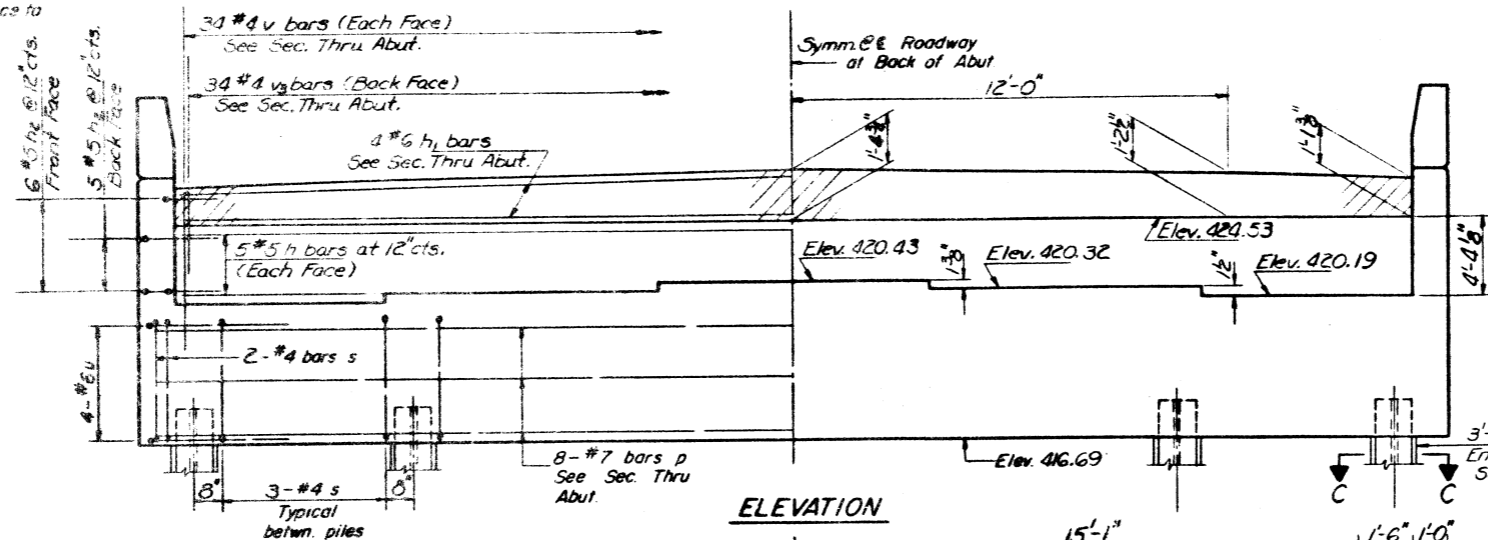
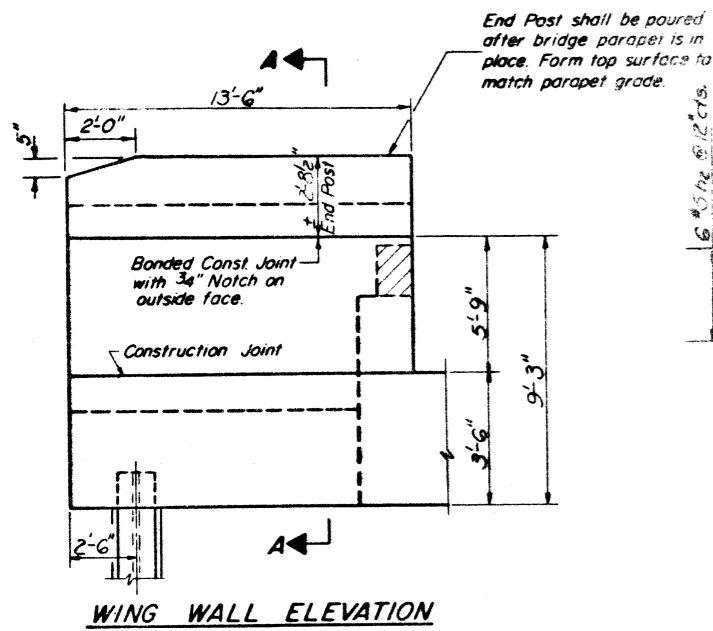

Space reinforcement in cap to miss anchor bolts.  
Four steps monolithically with cap.  
Hatched area shall be poured after superstructure is in place.  
All edges shall have a 3/8\"/>

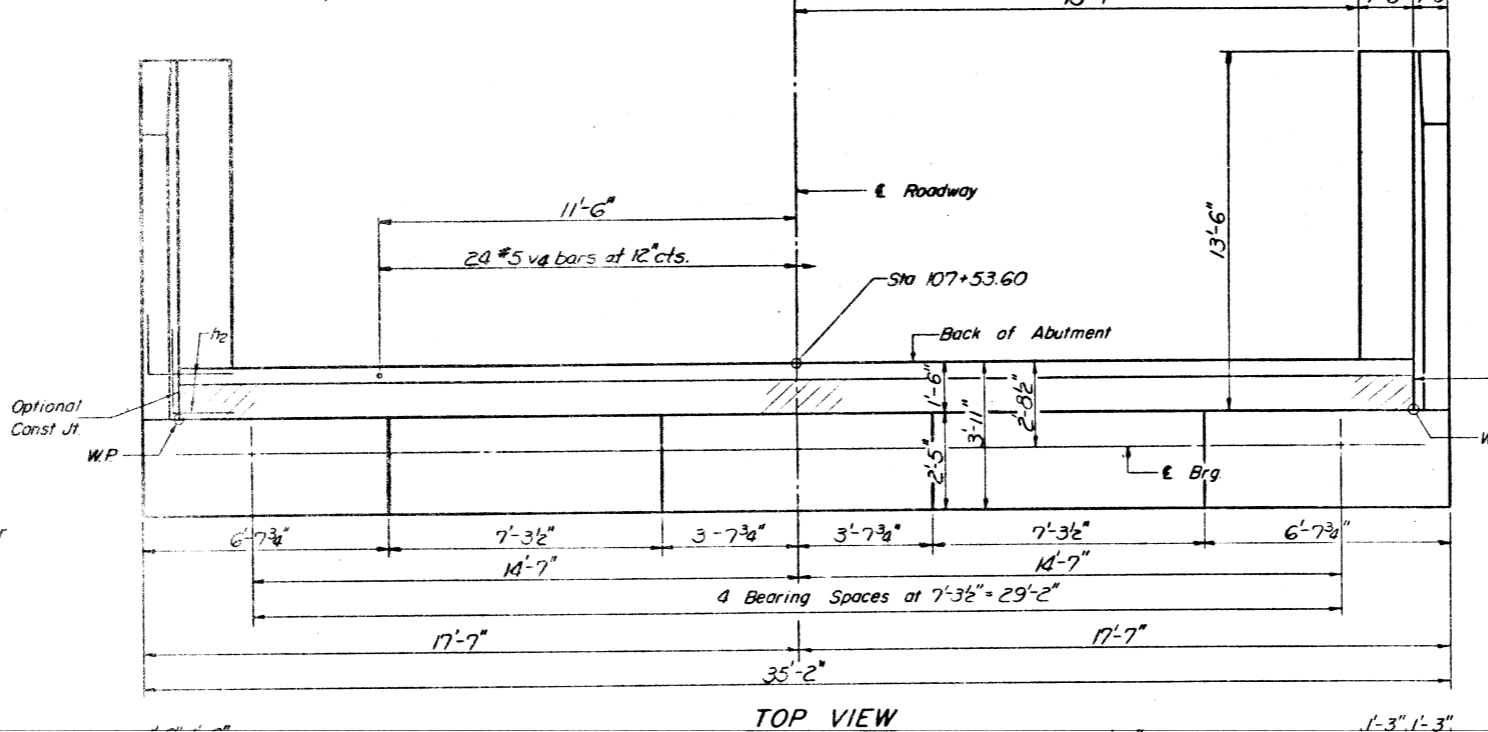
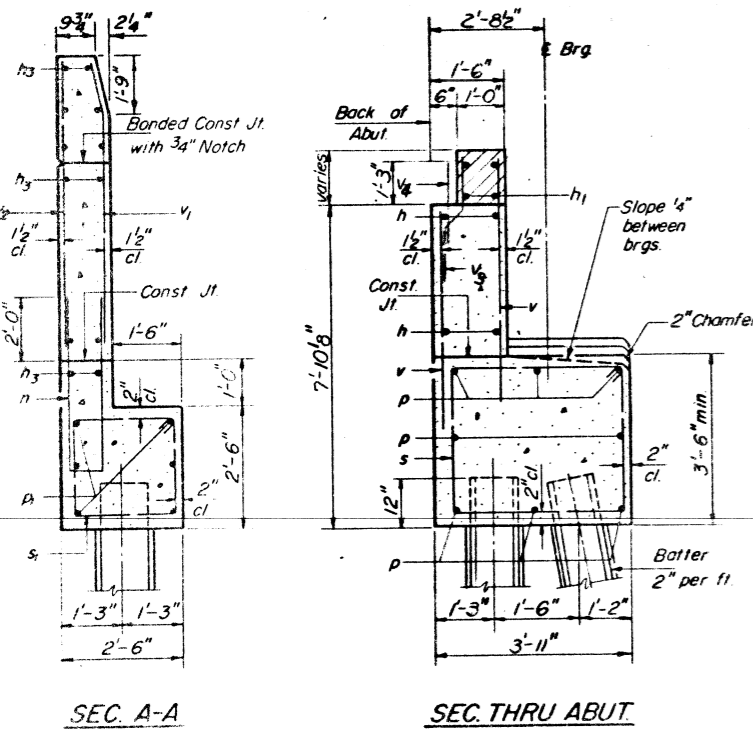
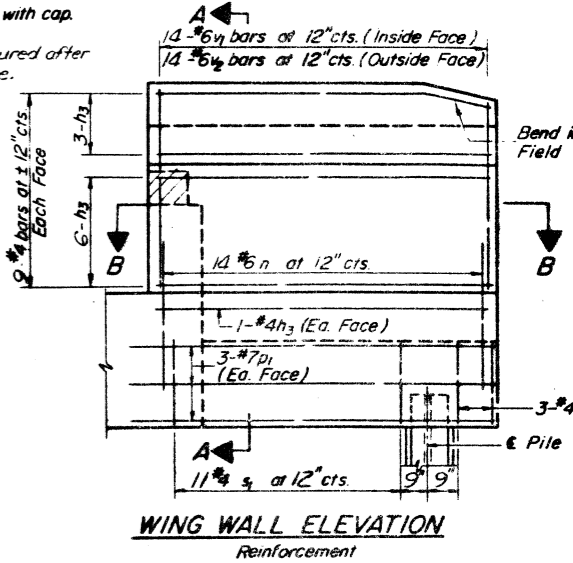

Welded wire fabric 6"x6" mesh #4 wire - weighing 58#/100 sq. ft. The cost of Class X Concrete Encasement and Reinforcement is incidental to the cost of furnishing piles. Forms for encasement may be omitted when soil conditions will permit.  
SEC. C-C

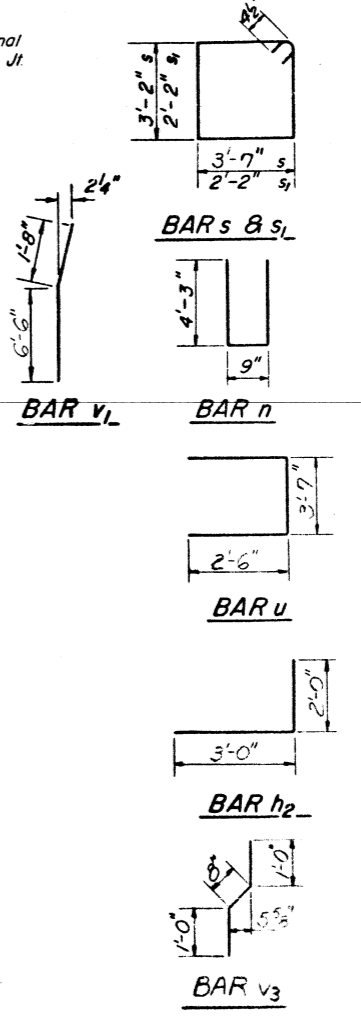

Bar	No	Size	Length	Shape
h	10	#5	33'-0"	—
h1	4	#6	33'-0"	—
h2	22	#5	3'-0"	—
h3	40	#4	13'-3"	—
n	25	#6	9'-3"	U
p	8	#7	34'-11"	—
pi	17	#7	13'-6"	—
s	32	#4	14'-3"	□
s1	28	#4	9'-5"	□
u	8	#6	8'-7"	—
v	65	#4	7'-0"	—
v1	25	#6	8'-2"	—
v2	20	#6	8'-2"	—
v3	33	#4	2'-8"	—
w	24	#5	2'-6"	—

Class X Concrete	Cu Yds	40.8
Reinforcement Bars	Lbs	4030
Steel Piles (HF10x42)	Lin Ft	1720
Test Piles (Steel HF10x42)	Ea.	1

DESIGNED: DAVID KRULL  
CHECKED: [Signature]  
DRAWN: [Signature]  
CHECKED: [Signature]

EXAMINED: [Signature]  
PASSED: [Signature]  
APPROVED: [Signature]  
DIRECTOR OF HIGHWAYS

WEST ABUTMENT  
F.A. RT. 746 SEC. 120BR  
JEFFERSON COUNTY  
STATION 110+76.92



STATE OF ILLINOIS  
DEPARTMENT OF TRANSPORTATION

ROUTE NO.	SECTION	PROJECT	TOTAL SHEETS	SHEET NO.	SHEET NO. 14
726	120BR	Jefferson	37	21	21 SHEETS

End Post shall be poured after bridge parapet is in place. Form top surface to match parapet grade.

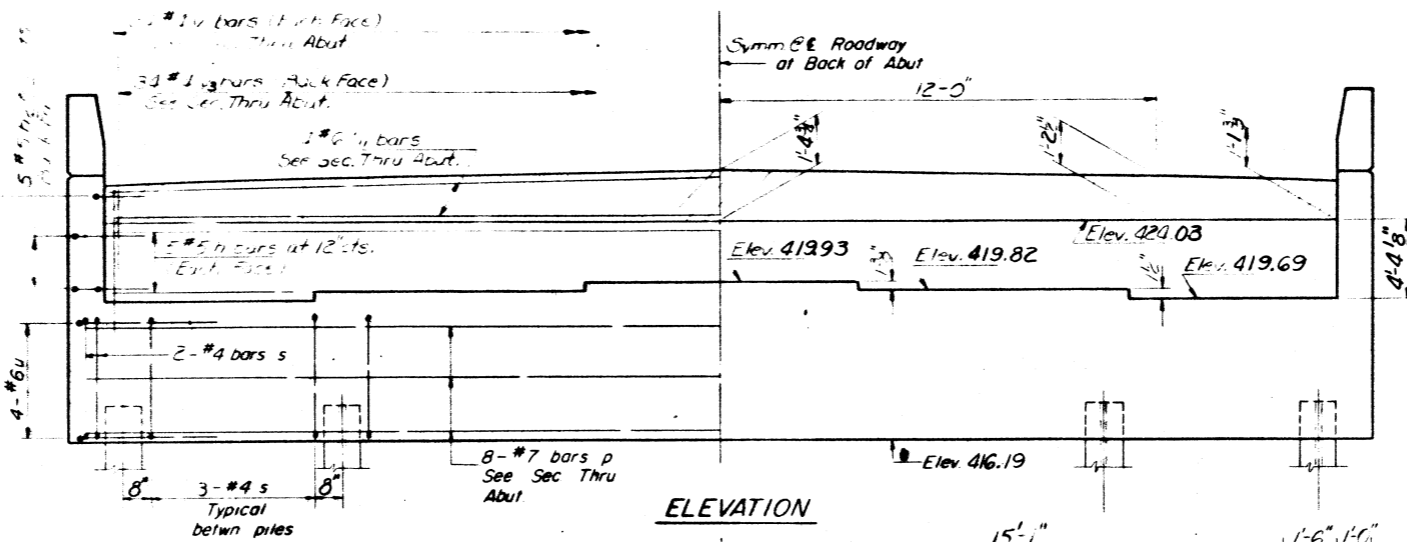
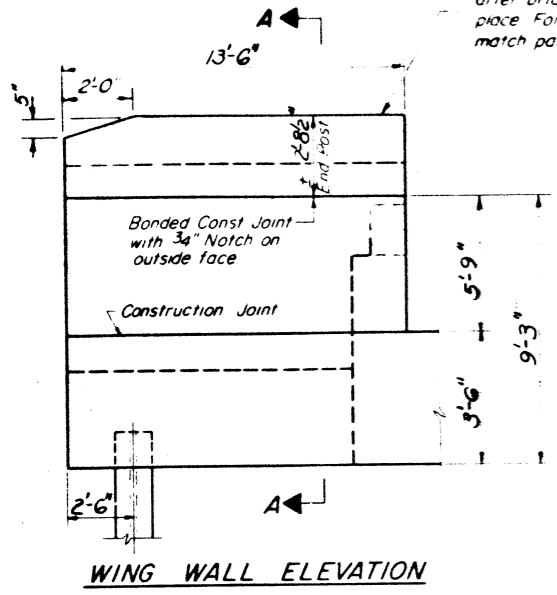

Space reinforcement in cap to miss anchor bolts.  
Four steps monolithically with cap.  
Hand finished shall be required after superstructure is in place.  
All edges shall have a 3/8\"/>

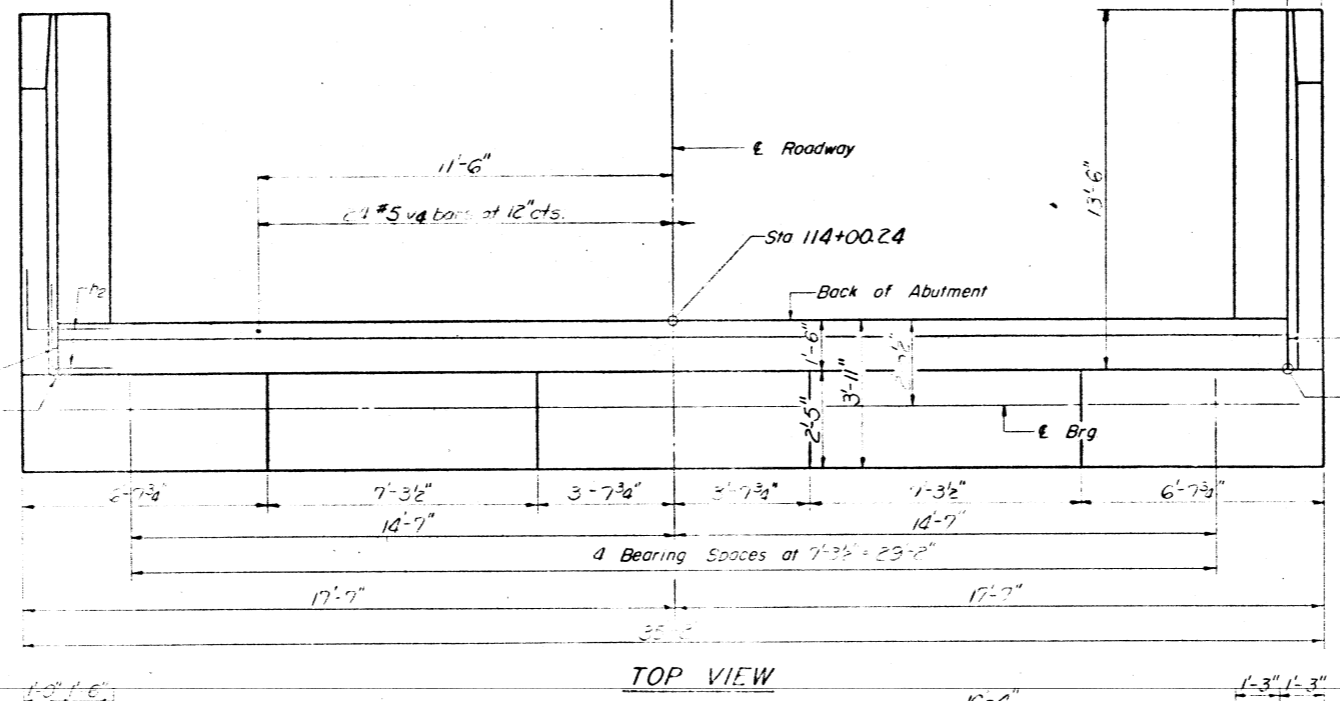
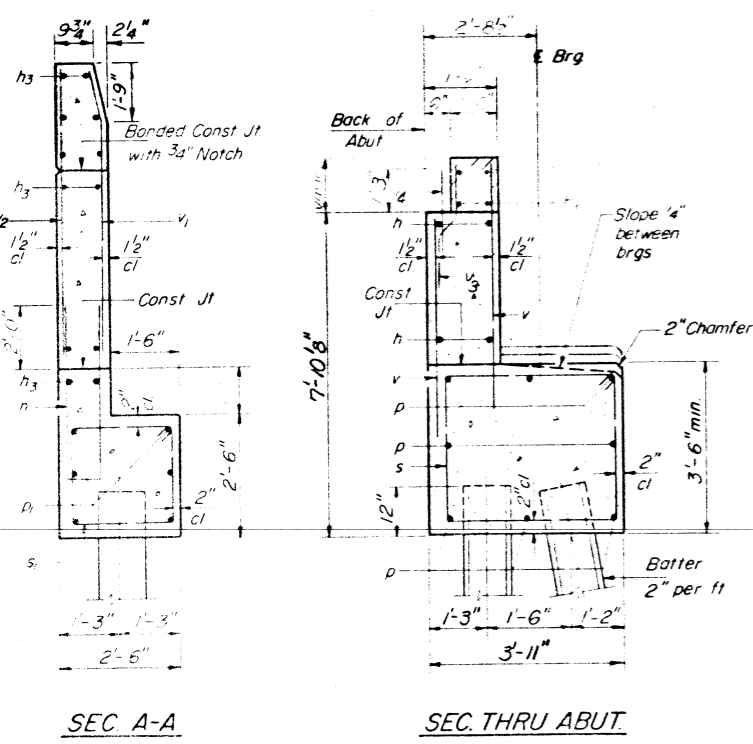
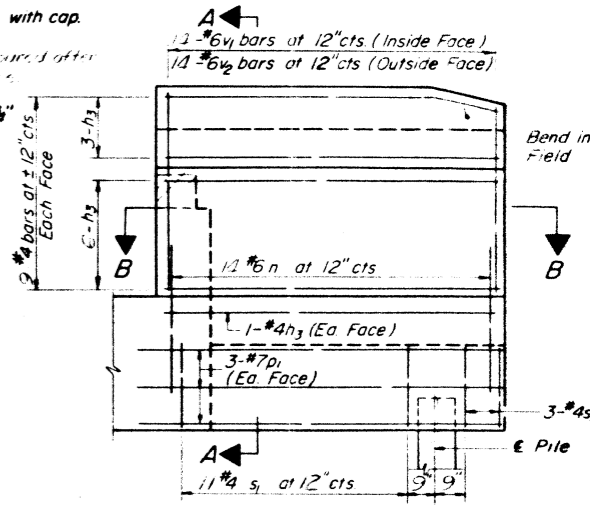

**PILE DATA**

Type	Steel HPI0x42
Capacity	Drive to Refusal
Est Length	34
No. Required	10 + 1 Test Pile
	placed in a convenient location.

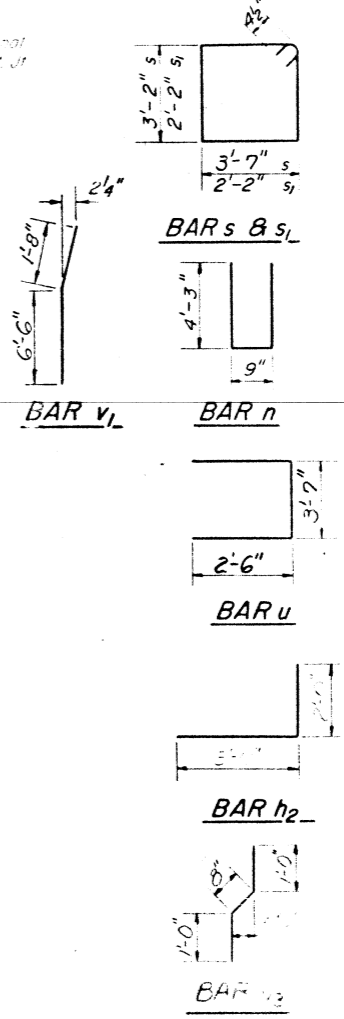

**BILL OF MATERIAL**

Bar	Qty	Size	Shape
h1		#6	U
h2		#5	U
h3		#4	U
n		#5	U
s		#2	U
s		#3	U
u		#6	U
v		#2	U
v1		#6	U
v2		#6	U
v3		#6	U
W.P.		#6	U

Class X Concrete      60 KPS      20.9  
Reinforcement Bars      25      2030  
Steel Piles (HPI0x42)      10 + 1      1068  
Test Piles (HPI0x42)      1      1

DESIGNED JAU KRULL  
CHECKED GUYO BEMETTE  
DRAWN J  
CHECKED JAU

EXAMINED *March 27 1977*  
PASSED *Carl E. ...*  
APPROVED \_\_\_\_\_  
DIRECTOR OF HIGHWAYS

EAST ABUTMENT  
F.A. RT. 106

STATE OF ILLINOIS  
DEPARTMENT OF TRANSPORTATION

ROUTE NO.	SECTION	COUNTY	TOTAL SHEETS	SHEET NO.	SHEET NO. 15 21 SHEETS
726	120 BR	Jefferson	37	22	
FED. ROAD DIST. NO. 7		ILLINOIS	FED. AID PROJ. NO.		

FILE DATA

Type: Steel (HP 10x42)  
Capacity: Drive to Refusal  
Est. Length: 53  
No. Reqd.: 14

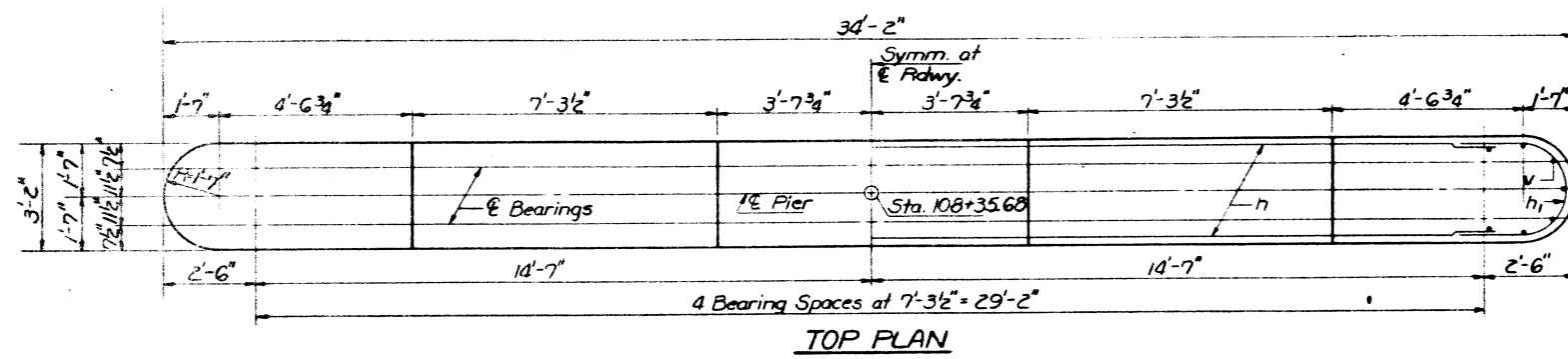

TOP PLAN

Notes: Four steps monolithically.  
All edges shall have a 3/8" chamfer except as noted.

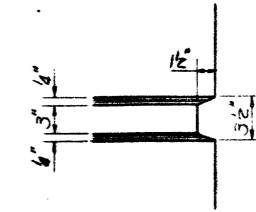

NOTCH DETAIL

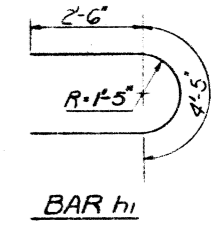

BAR h1

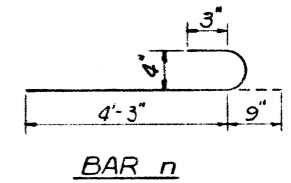

BAR n

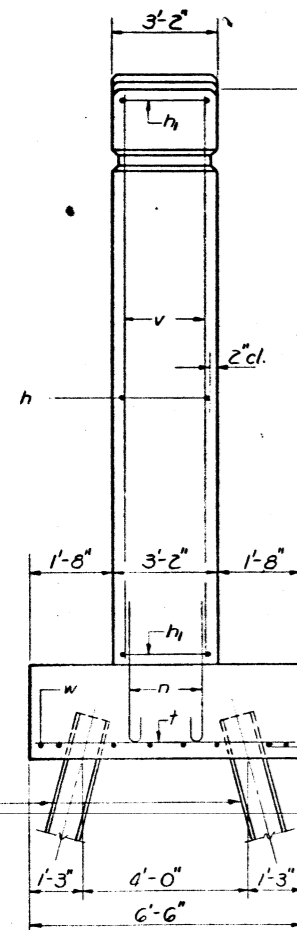

END VIEW

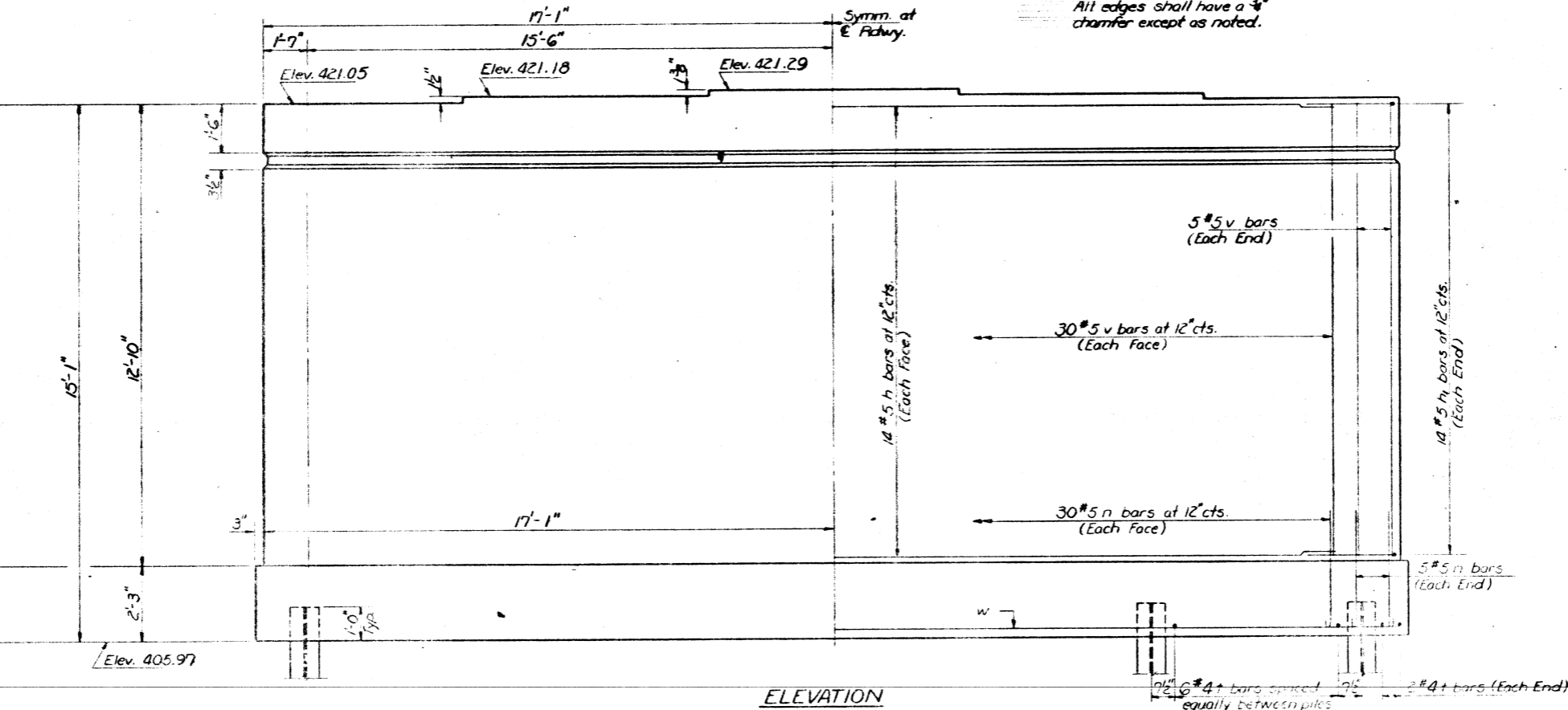

ELEVATION

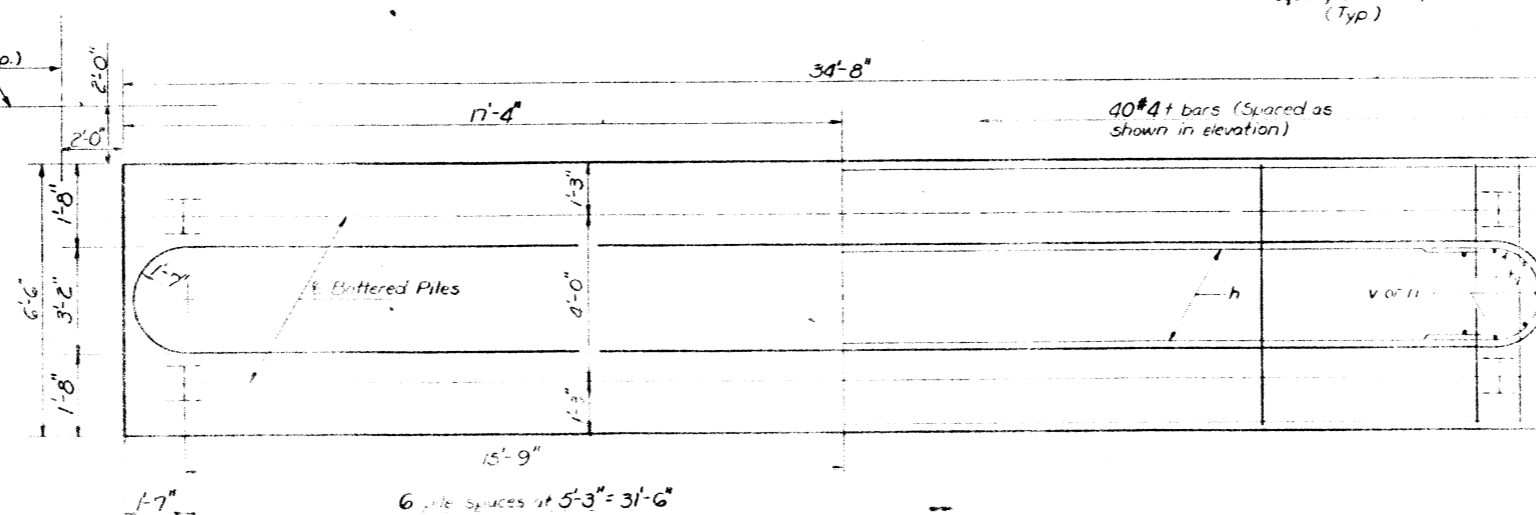

LAYOUT PLAN

BILL OF MATERIAL

Bar	No	Size	Length	Shape
h	28	#5	29'-4"	U
h1	28	#5	9'-5"	U
n	70	#5	5'-0"	U
t	40	#4	6'-3"	—
v	70	#5	12'-7"	—
w	8	#5	34'-5"	—
Class X Concrete		Cu Yd	69.5	
Reinforcement Bars		Pound	2870	
Steel Piles (HP 10x42)		Lin Ft	742	

DESIGNED DAN KRULL  
CHECKED R. J. BOHRE  
DRAWN  
CHECKED RAB

EXAMINED *Carl E. ...*  
PASSED  
APPROVED

March 27 1977

PIER 1  
F.A. RT. 726 SEC. 120 BR  
JEFFERSON COUNTY  
STATION 110+16.92

STATE OF ILLINOIS  
DEPARTMENT OF TRANSPORTATION

ROUTE NO.	SECTION	COUNTY	TOTAL SHEETS	SHEET NO.	SHEET NO. 16 21 SHEETS
726	120 BR	Jefferson	37	23	
FED. ROAD DIST. NO. 7		ILLINOIS	PIER AND PROJECT		

PILE DATA

Type: Steel (HP10x42)  
Capacity: Drive to Refusal  
Est. Length: 53'  
No. Req'd.: 12

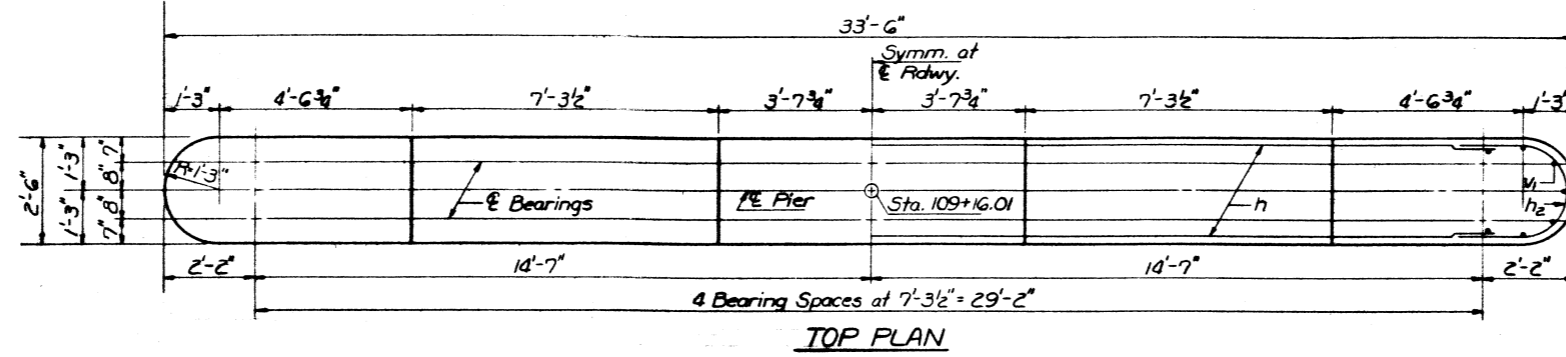

TOP PLAN

Notes: Four steps monolithically.  
All edges shall have a 3/8" chamfer except as noted.

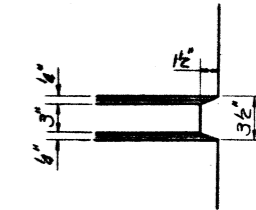

NOTCH DETAIL

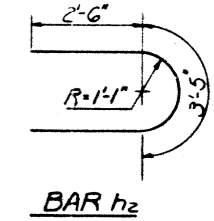

BAR h2

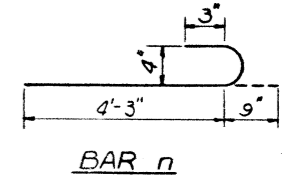

BAR n

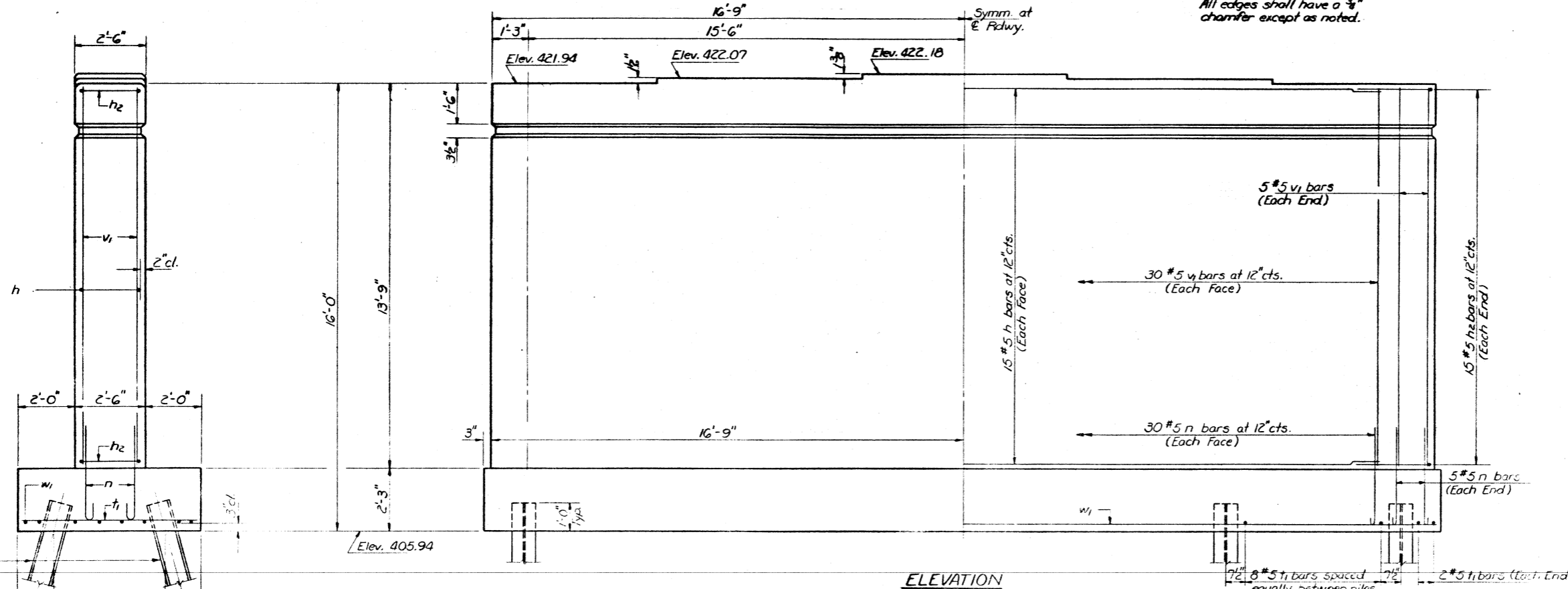

ELEVATION

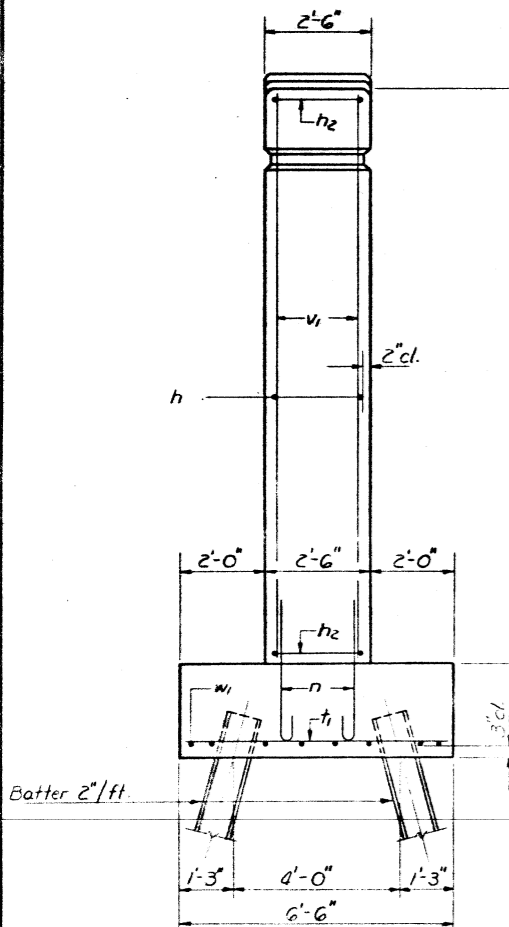

END VIEW

Batter 2" / ft.

Sheet Piling (Typ)

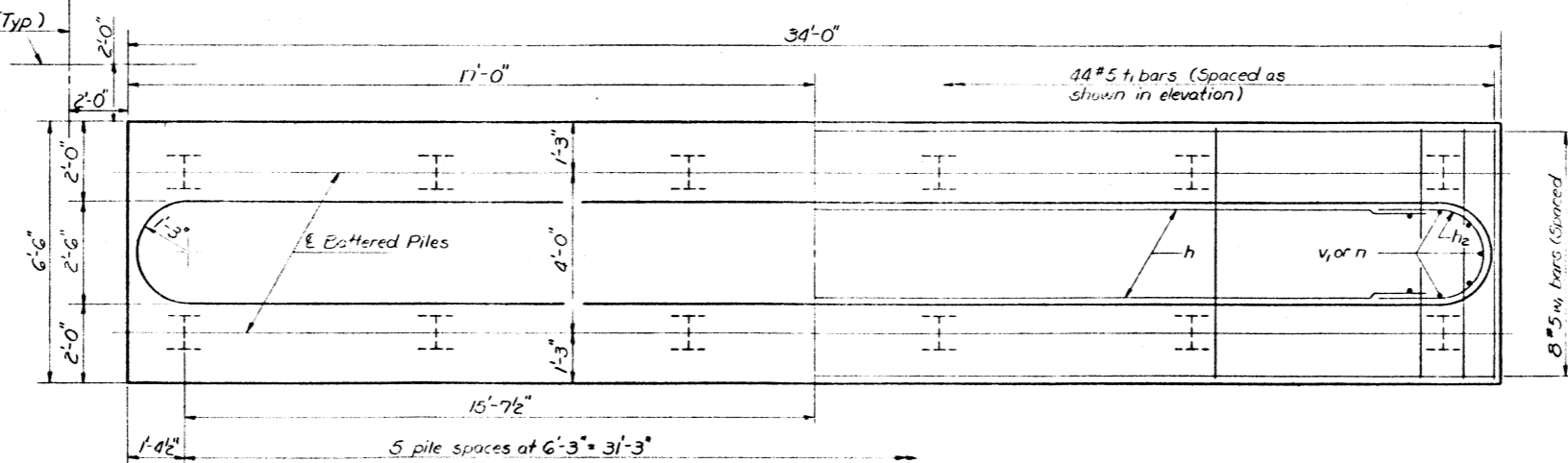

FOOTING PLAN

BILL OF MATERIAL

Bar	No	Size	Length	Slope
h	30	#5	29'-4"	—
h2	30	#5	8'-5"	—
n	70	#5	5'-0"	—
t1	44	#5	6'-3"	—
v1	70	#5	13'-6"	—
w1	8	#5	33'-9"	—
Class X Concrete		Cu Yd.	20.6	
Reinforcement Bars		Pounds	3,100	
Steel Piles (HP10x42)		Lin Ft	632	

DESIGNED	D.M. KULL
CHECKED	RICHARD R. KENNEDY
DRAWN	Joe Sutherland
CHECKED	C.M.

Examined *Mud 27 1979*  
PASSED  
APPROVED  
DIRECTOR OF HIGHWAYS

PIER 2  
FA. RT. 726 SEC. 120 BR  
JEFFERSON COUNTY  
STATION 110+16.92

STATE OF ILLINOIS  
DEPARTMENT OF TRANSPORTATION

ROUTE NO.	SECTION	COUNTY	TOTAL SHEETS	SHEET NO.	SHEET NO. 17
726	120 BR	Jefferson	37	24	21 SHEETS
FED. ROAD DIST. NO. 7		ILLINOIS	FED. AID PROJECT		

PILE DATA

Type: Steel (HP 10x42)  
Capacity: Drive to Refusal  
Est. Length: 53'  
No. Req'd.: 14

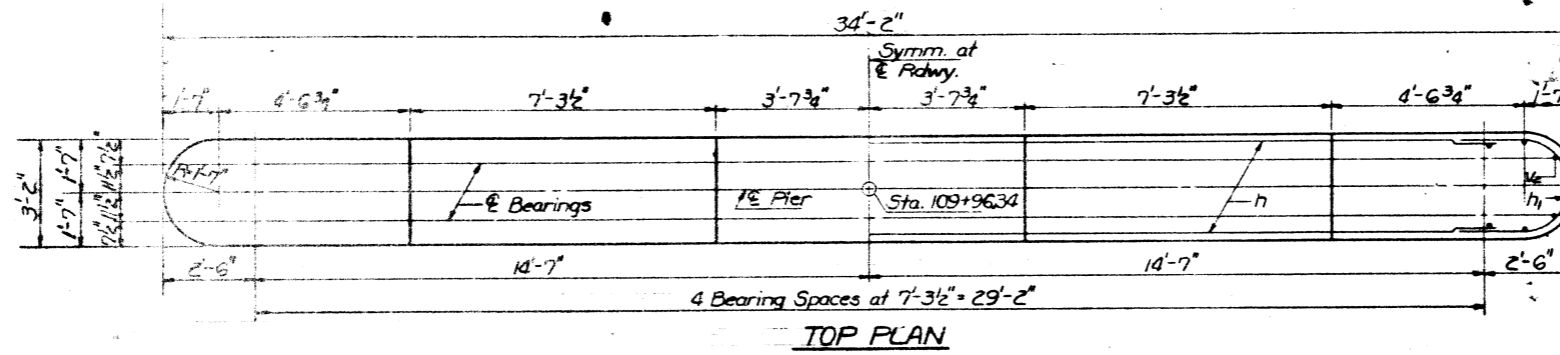

TOP PLAN

Notes: Four steps monolithically.  
All edges shall have a 3/8" chamfer except as noted.

NOTCH DETAIL

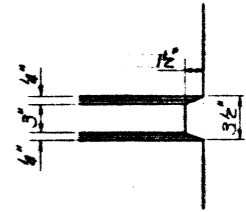

BAR h<sub>1</sub>

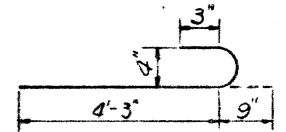

BAR n

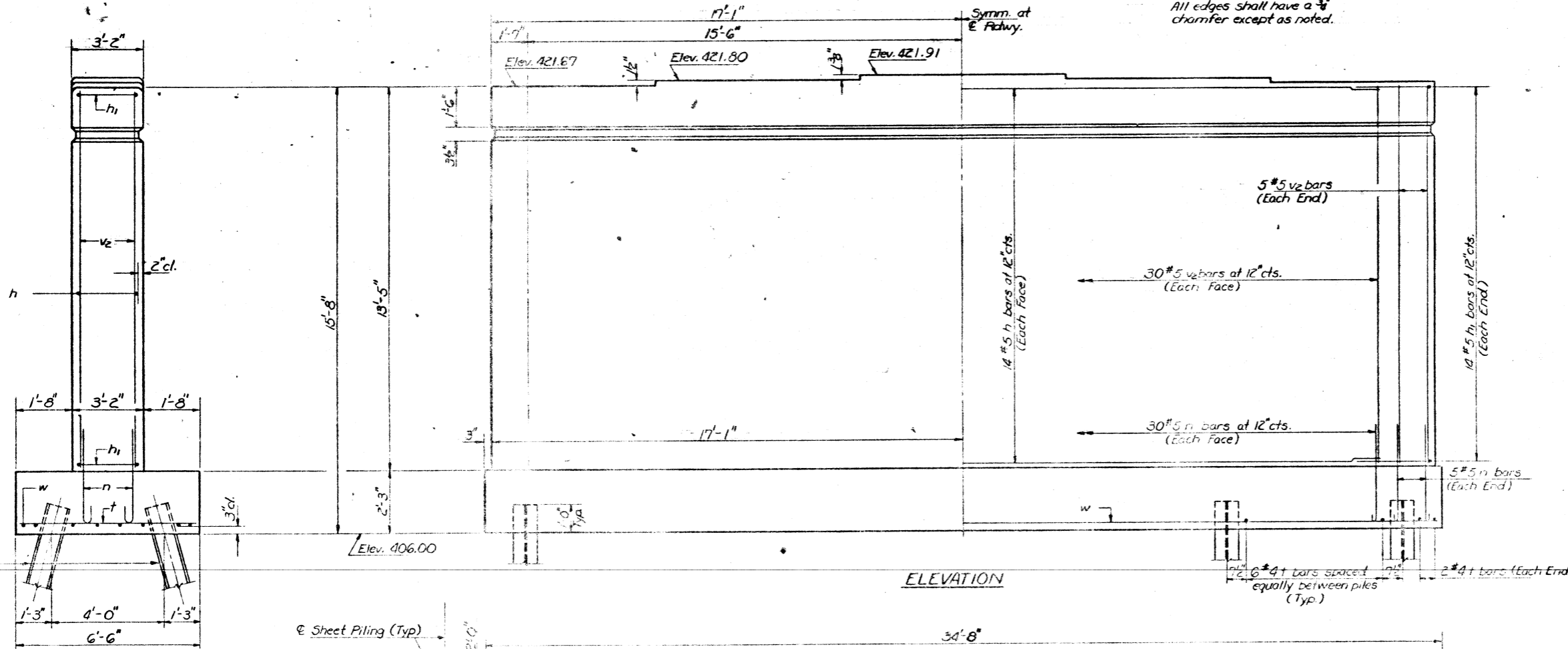

ELEVATION

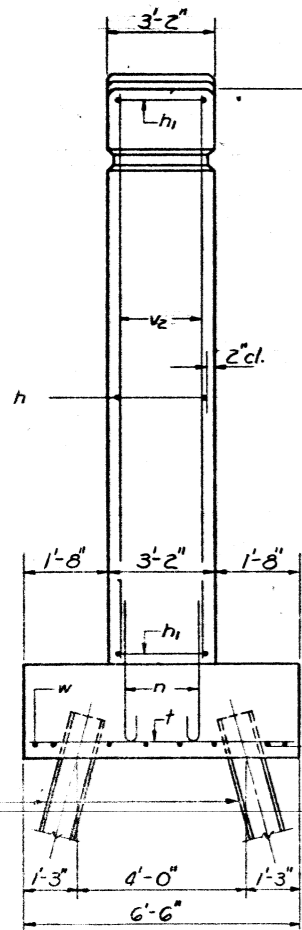

END VIEW

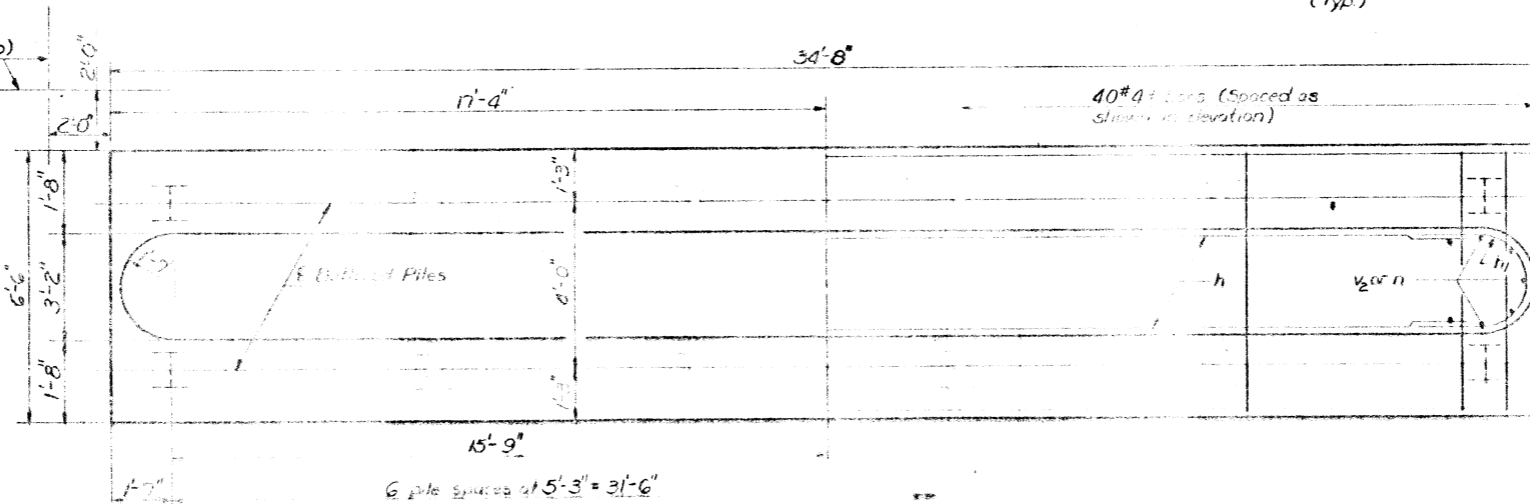

FOOTING PLAN

BILL OF MATERIAL

Bar	No	Size	Length	Shape
h	28	#5	29'-4"	—
h <sub>1</sub>	28	#5	9'-5"	—
n	70	#5	5'-0"	—
t	40	#4	6'-3"	—
v <sub>2</sub>	70	#5	13'-2"	—
w	8	#5	34'-5"	—
Class X Concrete				
Reinforcement Bars				
Steel Piles (HP 10x42)				

DESIGNED	DNO Kroll
CHECKED	W. J. Safford
DRAWN	W. J. Safford
CHECKED	W. J. Safford

EXAMINED *March 27 1979*  
PASSED *Carl E. ...*  
APPROVED

PIER 3  
F.A. RT. 726 SEC. 120 BR  
JEFFERSON COUNTY  
STATION 110+76.92

STATE OF ILLINOIS  
DEPARTMENT OF TRANSPORTATION

PROJECT NO.	SECTION	QUANTITY	TOTAL SHEETS	SHEET NO.
120 BR	Jefferson	37	25	21

SHEET NO. 18  
21 SHEETS

FILE DATA

Type: Steel (HP 10x42)  
Capacity: Drive to Refusal  
Est. Length: 53'  
No. Req'd.: 11 + 1 Test Pile placed in a permanent location

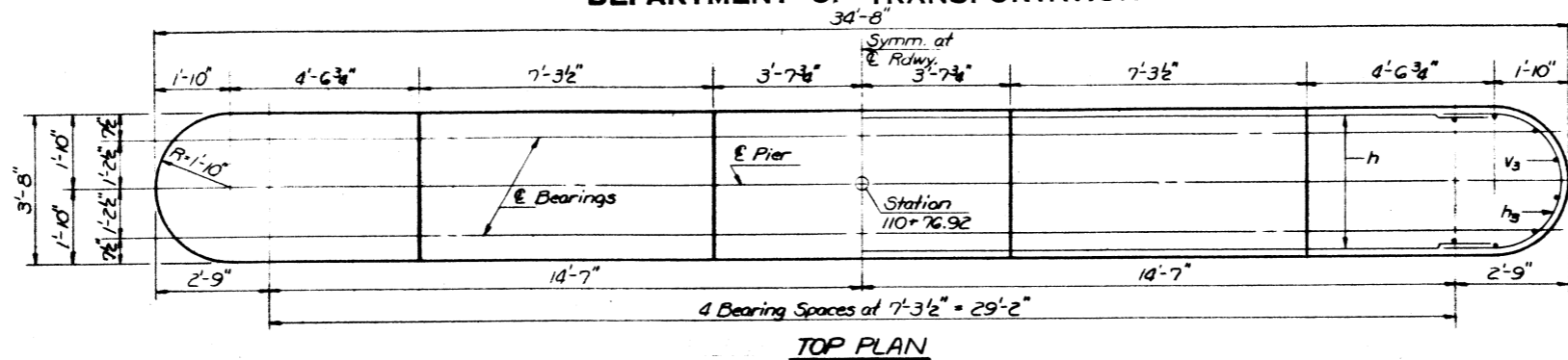

TOP PLAN

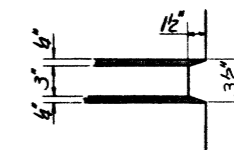

NOTCH DETAIL

Notes: Four steps monolithically.  
All edges shall have a 3/4" chamfer except as noted.

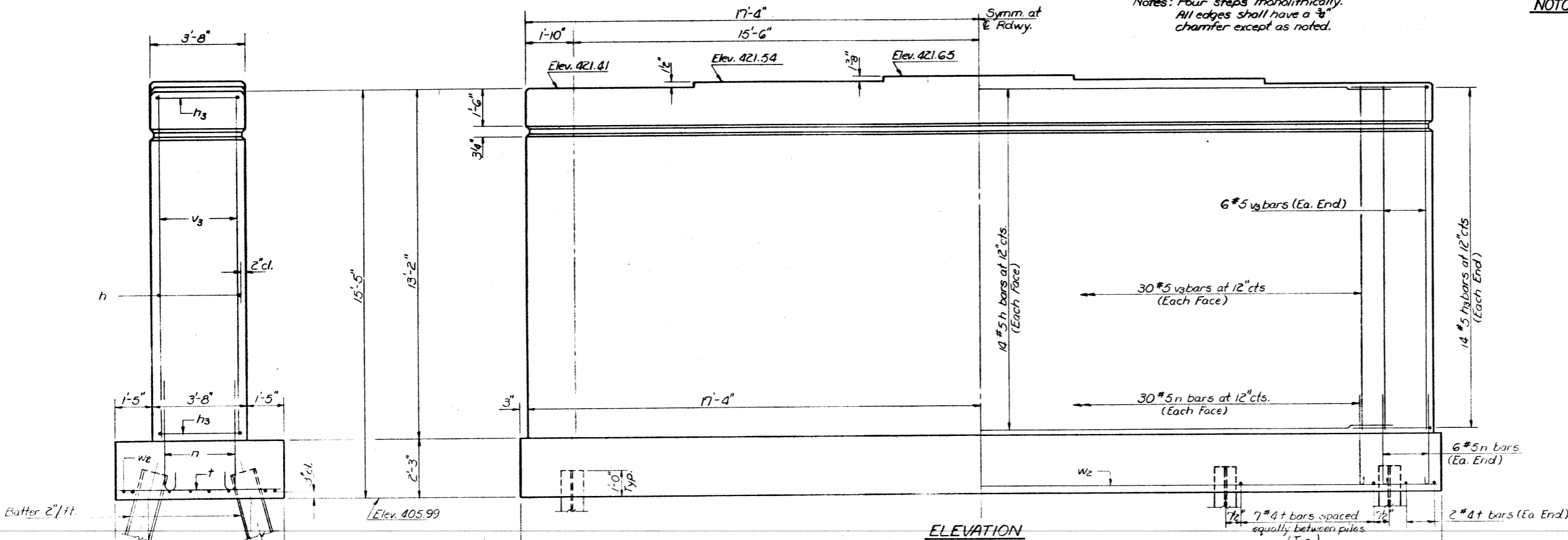

ELEVATION

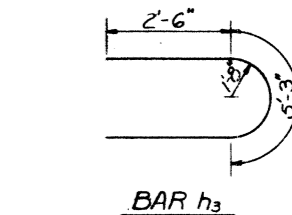

BAR h3

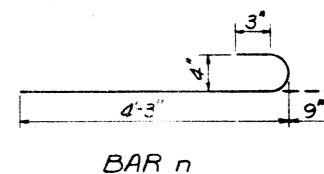

BAR n

BILL OF MATERIAL

Bar	No.	Size	Length	Shape
h	28	#5	29'-4"	U
h3	28	#5	10'-3"	U
n	72	#5	5'-0"	U
t	39	#4	6'-3"	—
v3	72	#5	12'-11"	—
w2	8	#5	34'-11"	—
Class X Concrete		Cu. Yd.	80.1	
Reinforcement Bars		Pound	2960	
Steel Piles (HP10x42)		Lin. Ft.	583	
Test Piles Steel (HP10x42)		Each	1	

Batter 2"/ft.

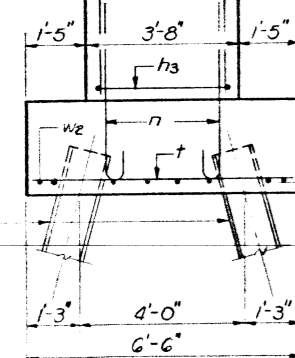

END VIEW

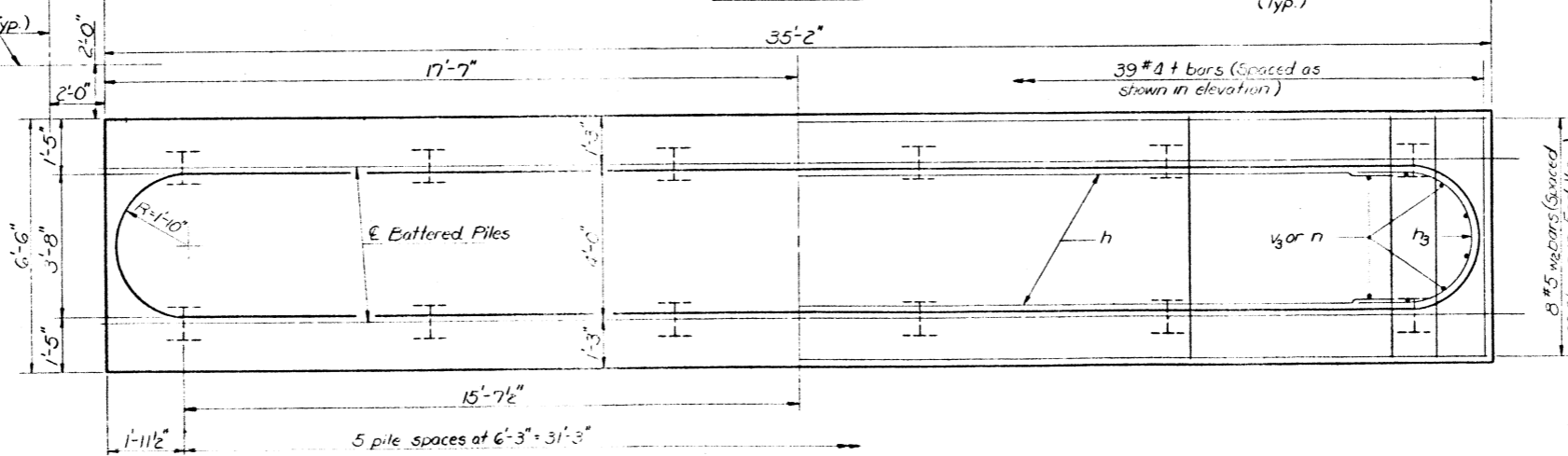

FOOTING PLAN

DESIGNED	DAU KRILL
CHECKED	J. S. WHITE
DRAWN	J. S. SUTHERLAND
CHECKED	

Examined: *March 22, 1979*  
G. J. [Signature]  
ENGINEER OF BRIDGES AND TRAFFIC STRUCTURES  
APPROVED: \_\_\_\_\_  
ENGINEER OF DESIGN  
DIRECTOR OF HIGHWAYS

PIER 4  
F.A. RT. 726 SEC 120BR  
JEFFERSON COUNTY  
STATION 110+76.92

STATE OF ILLINOIS  
DEPARTMENT OF TRANSPORTATION

PROJECT NO.	120BR	SECTION	37	26	PIER 5
DATE	120BR	JEFFERSON	37	26	21 SHEETS

FILE DATA

Type: Steel (HP 10x42)  
Drive to Refusal  
Pile Length: 38'  
No. Piles: 16

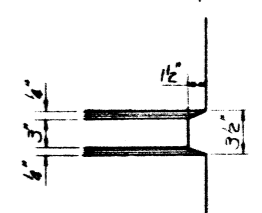
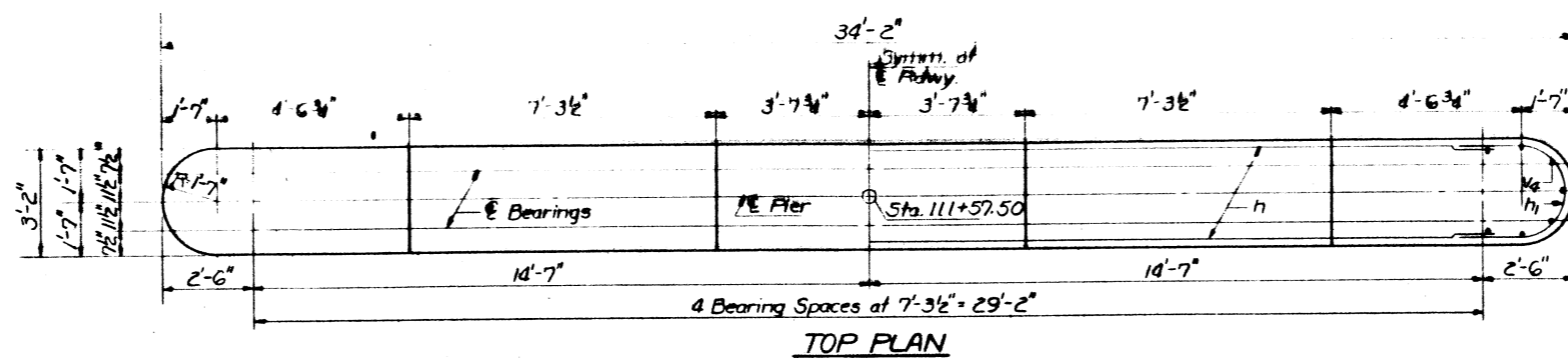

NOTCH DETAIL

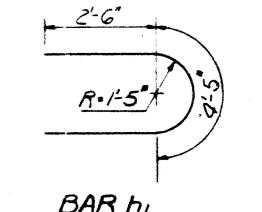

BAR h1

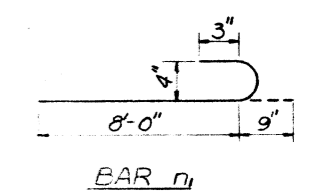

BAR n1

Notes: Four steps monolithically.  
All edges shall have a 3/8" chamfer except as noted.

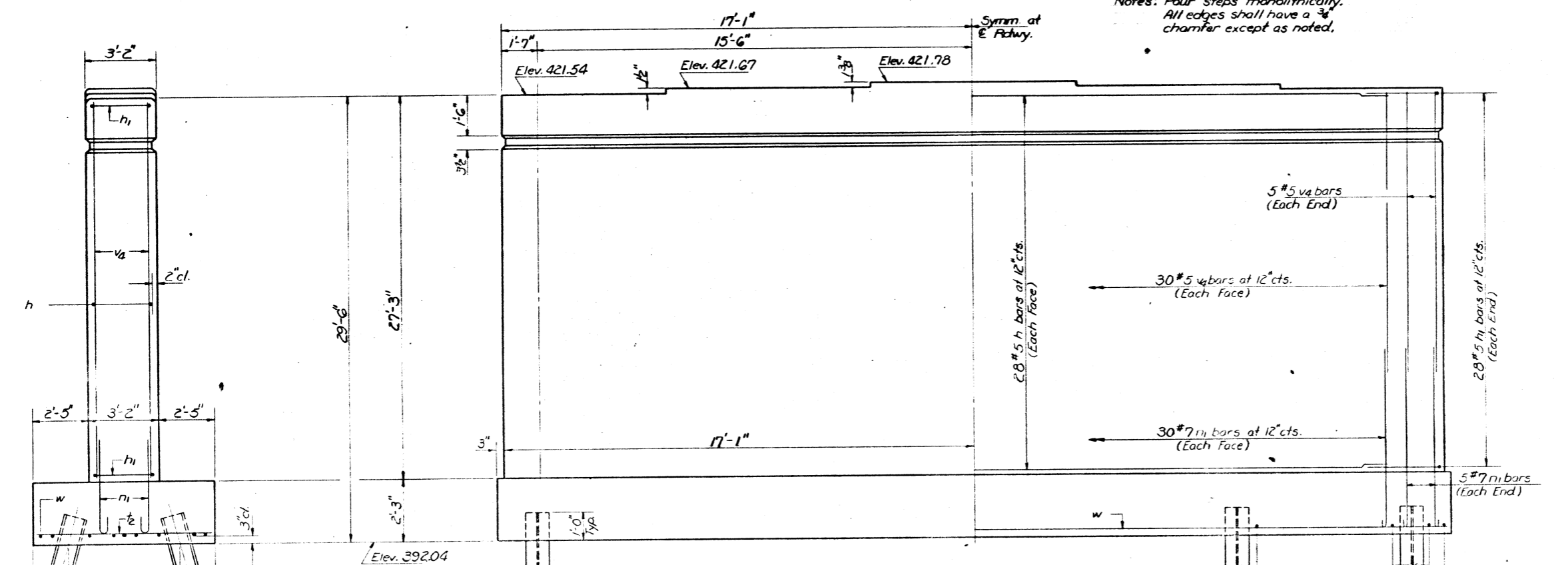

ELEVATION

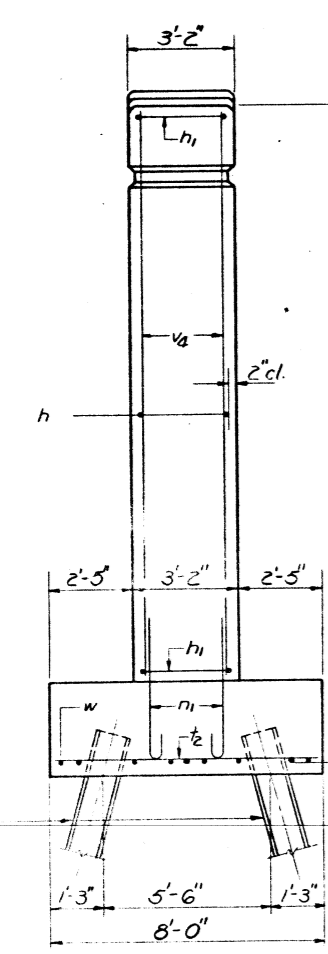

END VIEW

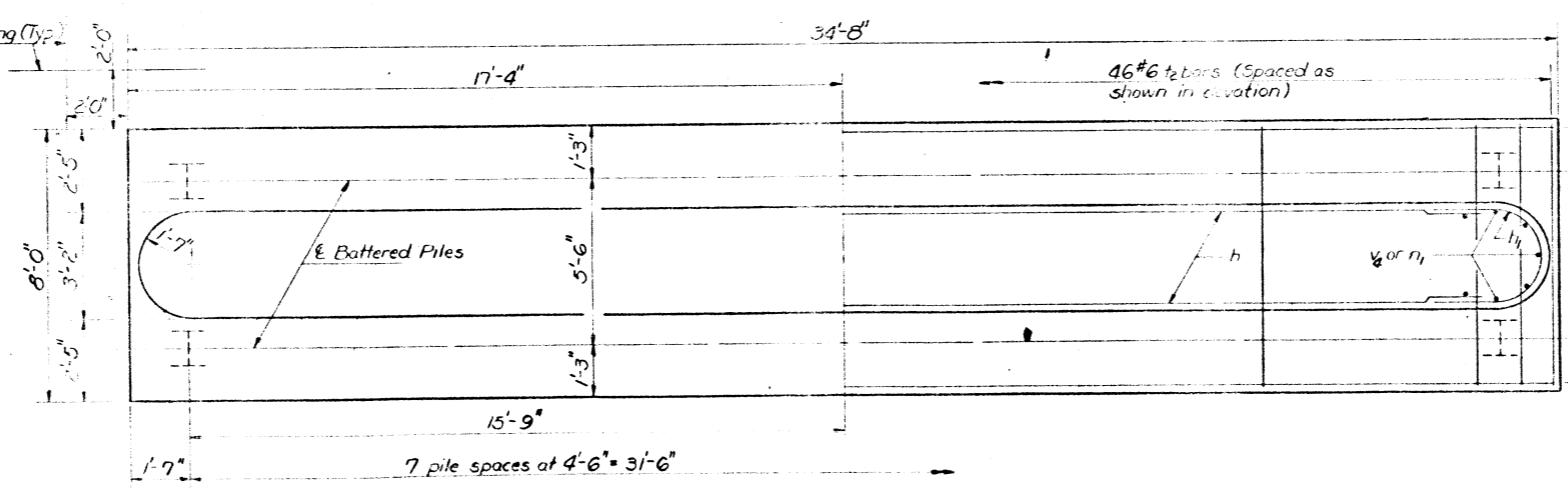

FOOTING PLAN

BILL OF MATERIAL

Exp.	No.	Size	Length	Shape
n	56	#5	29'-4"	—
h1	56	#5	9'-5"	U
n1	70	#7	8'-9"	U
t2	46	#6	7'-9"	—
va	70	#5	22'-10"	—
w	9	#5	34'-5"	—

Class X Concrete      Cu Id. 130.5  
Reinforcement Bars      Pound 6043  
Steel Piles (HP10x42)      Lin Ft 605

DESIGNED	DAN KROLL
CHECKED	
DRAWN	Joe Sutherland
CHECKED	

March 27 1977  
EXAMINED *Carl E. ...*  
PASSED  
APPROVED

PIER 5  
FA. RT 726 SEC. 120 BR  
JEFFERSON COUNTY  
STATION 110+16.92

STATE OF ILLINOIS  
DEPARTMENT OF TRANSPORTATION

PROJECT NO.	SECTION	COUNTY	TOTAL SHEETS	SHEET NO.	SHEET NO. 20 21 SHEETS
726	120 BR	Jefferson	37	27	
DESIGNED BY	ILLINOIS	FOR AID PROJECT			

PILE DATA

Type: Steel (HP 10x42)  
Capacity: Drive to Refusal  
Est. Length: 51'  
No. Req'd.: 12

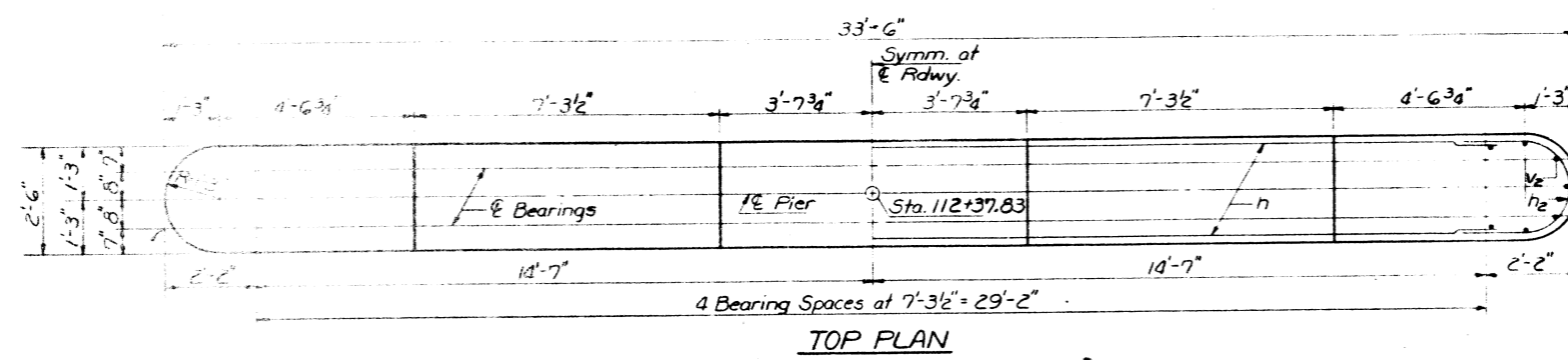

TOP PLAN

Notes: Four steps monolithically.  
All edges shall have a 3/8" chamfer except as noted.

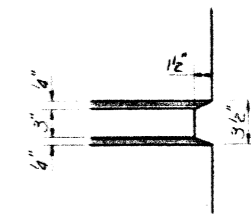

NOTCH DETAIL

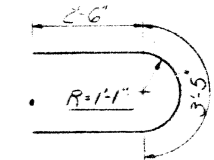

BAR h2

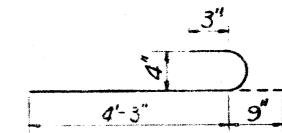

BAR n

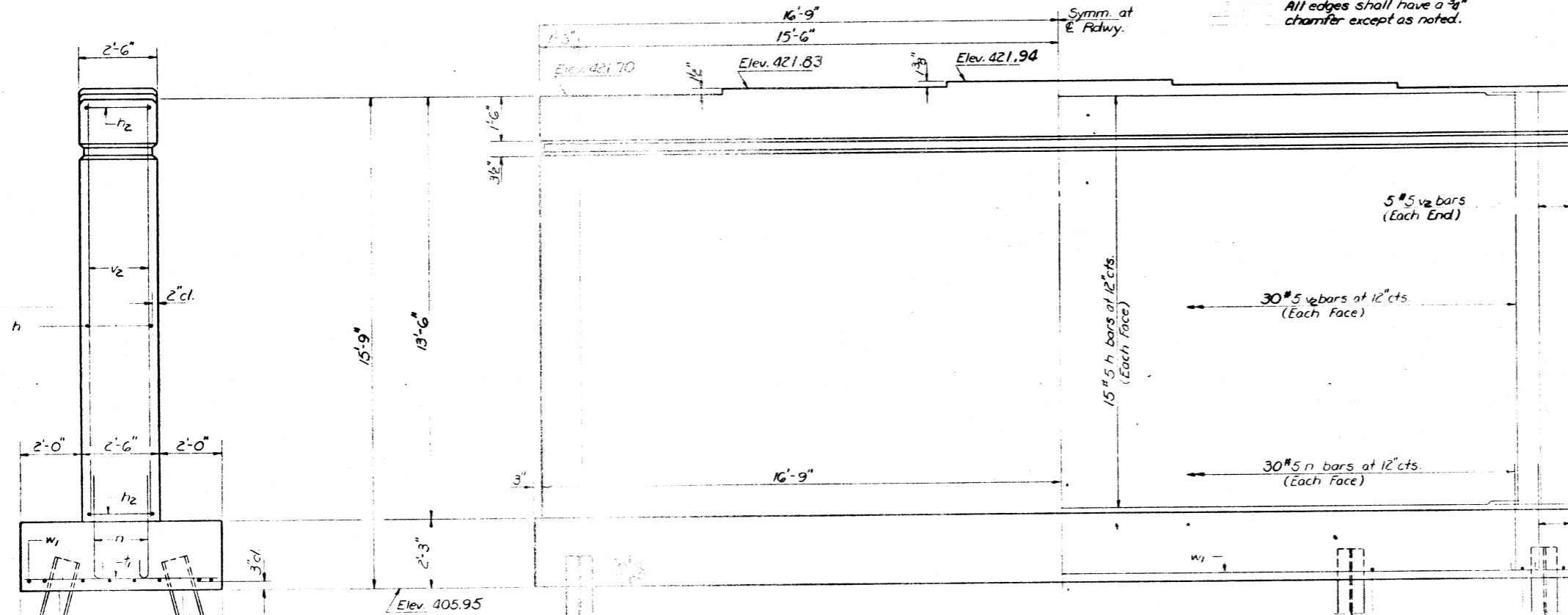

ELEVATION

BILL OF MATERIAL

Bar	No	Size	Length	Shape
h	30	#5	29'-4"	U
h2	30	#5	8'-5"	U
n	70	#5	5'-0"	U
t1	44	#5	6'-3"	—
v2	70	#5	13'-2"	—
w1	8	#5	33'-9"	—

  

Class X Concrete	Cu Yd	59.8
Reinforcement Bars	Poured	3080
Steel Piles (HP10x42)	Lin Ft	612

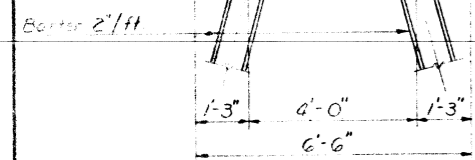

END VIEW

Sheet Piling (Typ.)

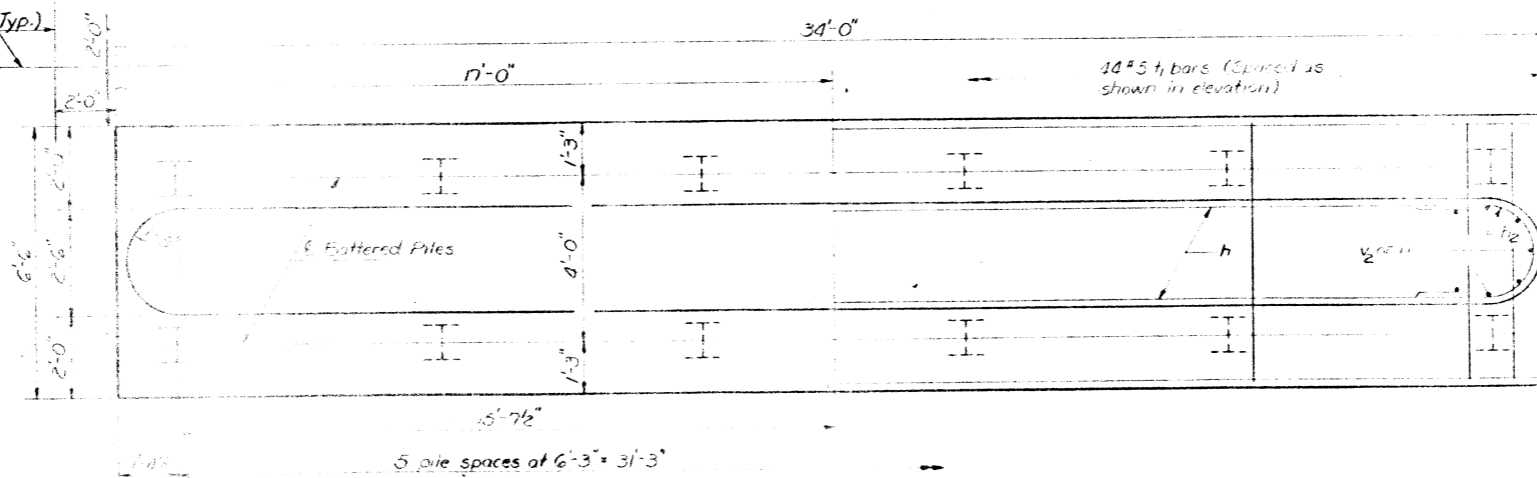

FOOTING PLAN

DESIGNED	DAV KROLL
CHECKED	PAUL B. HARRIS
DRAWN	Joe Sutherland
CHECKED	K.A.B.

EXAMINED March 27 1979  
Carl E. Hanover  
SUPERVISOR OF BRIDGE AND TRAFFIC STRUCTURES  
PASSED  
APPROVED  
DIRECTOR OF HIGHWAYS

PIER 6  
FA. RT 726 SEC. 120 BR  
JEFFERSON COUNTY  
STATION 110+76.92



STATE OF ILLINOIS  
DEPARTMENT OF TRANSPORTATION

FILE DATA

Type: Drive to Refusal  
Capacity: 53  
No. Piles: 14

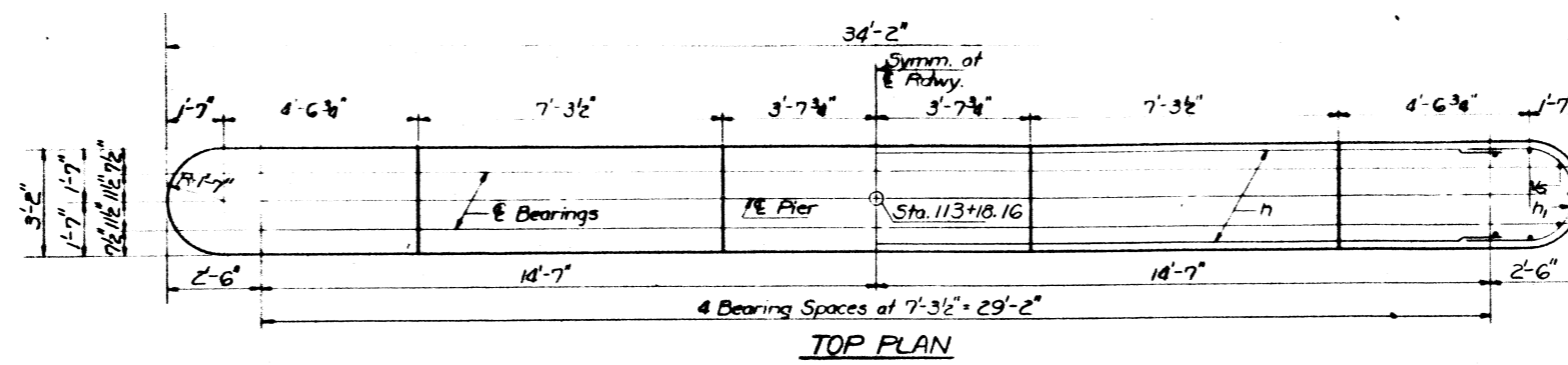

TOP PLAN

Notes: Four steps monolithically.  
All edges shall have a 3/8" chamfer except as noted.

NOTCH DETAIL

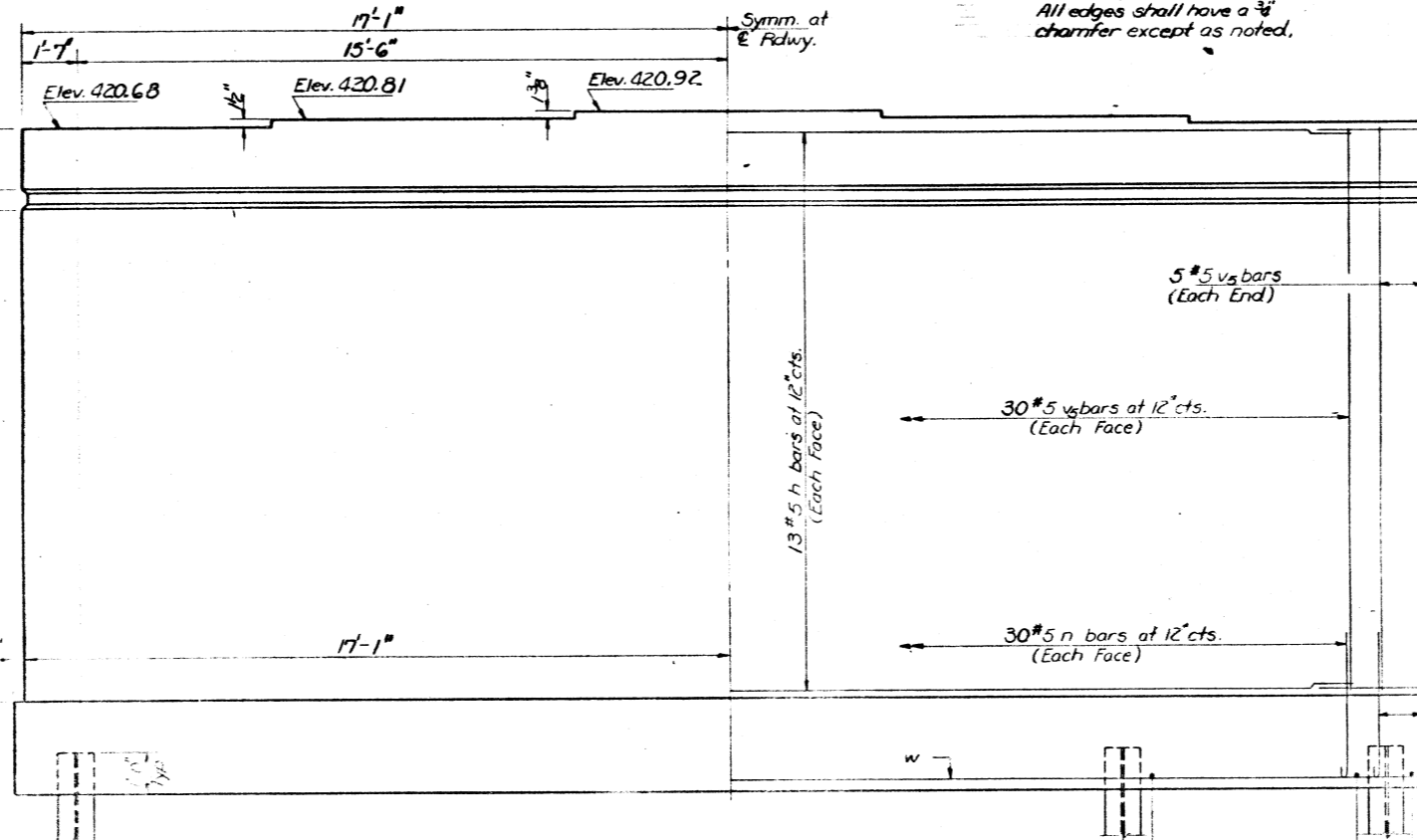
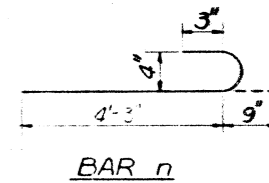
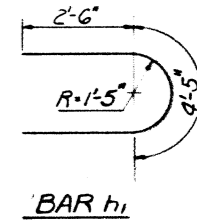
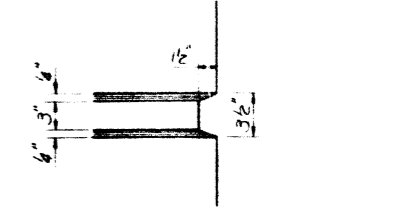

ELEVATION

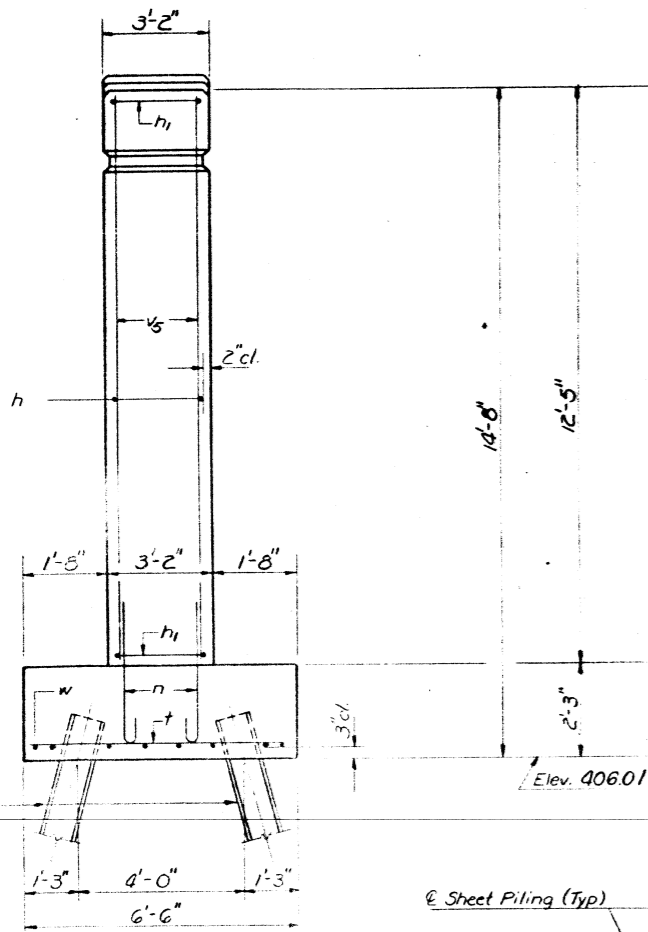

END VIEW

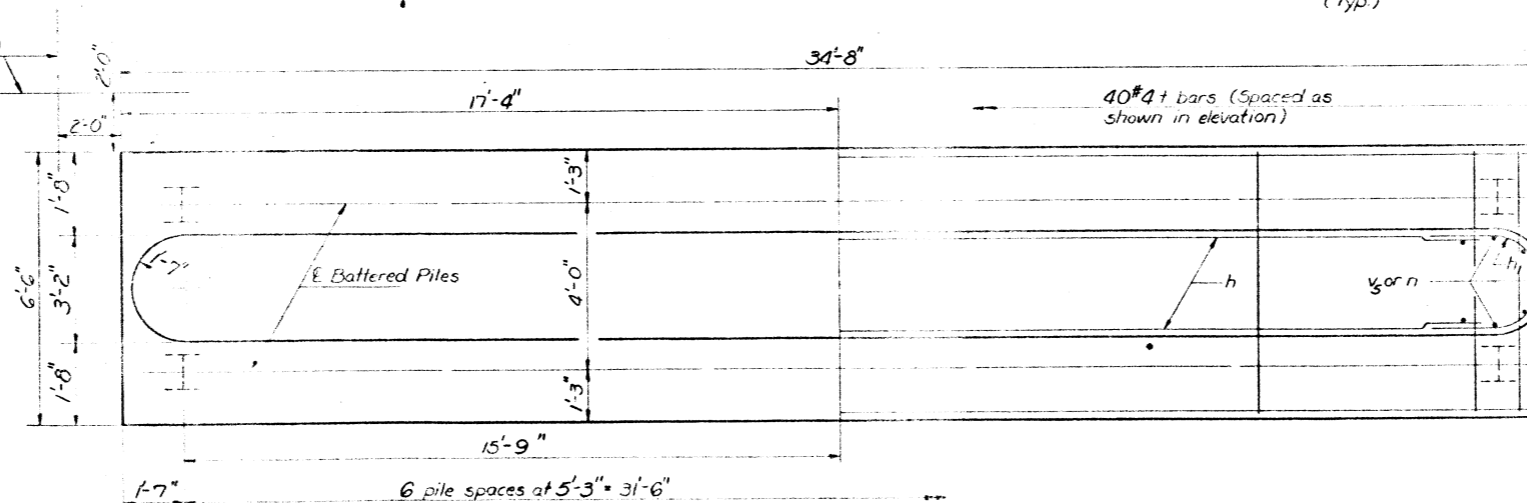

FOOTING PLAN

BILL OF MATERIAL

Bar No.	Size	Length	Slope
h	#5	29'-4"	—
n	#5	9'-5"	—
v	#5	5'-0"	—
t	#4	6'-3"	—
s	#5	12'-2"	—
4	#5	34'-5"	—

Class X Concrete 28 Day 37.8  
 Reinforcement Bars Found 27.2  
 Steel Piles (HP10x32) Lin P 142

DESIGNED DAV KRULL  
 CHECKED  
 DRAWN Joe Scherlock  
 CHECKED

EXAMINED *March 27 1979*  
 PASSED  
 APPROVED

PIER 7  
 FA. RT 726 SEC 120 BR  
 JEFFERSON COUNTY  
 STATION 110+18.92