

STATE OF ILLINOIS
DEPARTMENT OF TRANSPORTATION

F.A.P. RTE.	SECTION	COUNTY	TOTAL SHEETS	SHEET NO.
	20-00224-00-BT	COOK	89	1
ILLINOIS CONTRACT NO. 61J19				

PROPOSED HIGHWAY PLANS

FAU 1332 (OAKTON STREET) SIDEPATH
S. RIVER ROAD TO DES PLAINES RIVER TRAIL
SECTION 20-00224-00-BT
PROJECT #0E4U(312)
RESURFACING AND SHARED-USE PATH CONSTRUCTION
CITY OF DES PLAINES
COOK COUNTY
JOB NO. C-91-042-22

FOR INDEX OF SHEETS, SEE SHEET NO. 2

FOR LIST OF APPLICABLE HIGHWAY STANDARDS
SEE SHEET 2

THIS PROJECT PASSES THROUGH:
CITY OF DES PLAINES

TRAFFIC DATA
OAKTON STREET
FUNCTIONAL CLASSIFICATION: MINOR ARTERIAL
ADT=19,700 VEHICLES PER DAY
40 MPH POSTED SPEED



FEDERAL AID PROGRAM ENGINEER: CARMEN E. RAMOS, P.E., SCHALMBURG, ILLINOIS

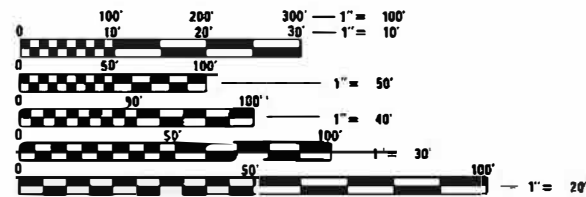

FULL SIZE PLANS HAVE BEEN PREPARED USING STANDARD ENGINEERING SCALES. REDUCED SIZED PLANS WILL NOT CONFORM TO STANDARD SCALES. IN MAKING MEASUREMENTS ON REDUCED PLANS THE ABOVE SCALES MAY BE USED.

J.U.L.I.E.
JOINT UTILITY LOCATION INFORMATION FOR EXCAVATION
1-800-892-0123
OR 811

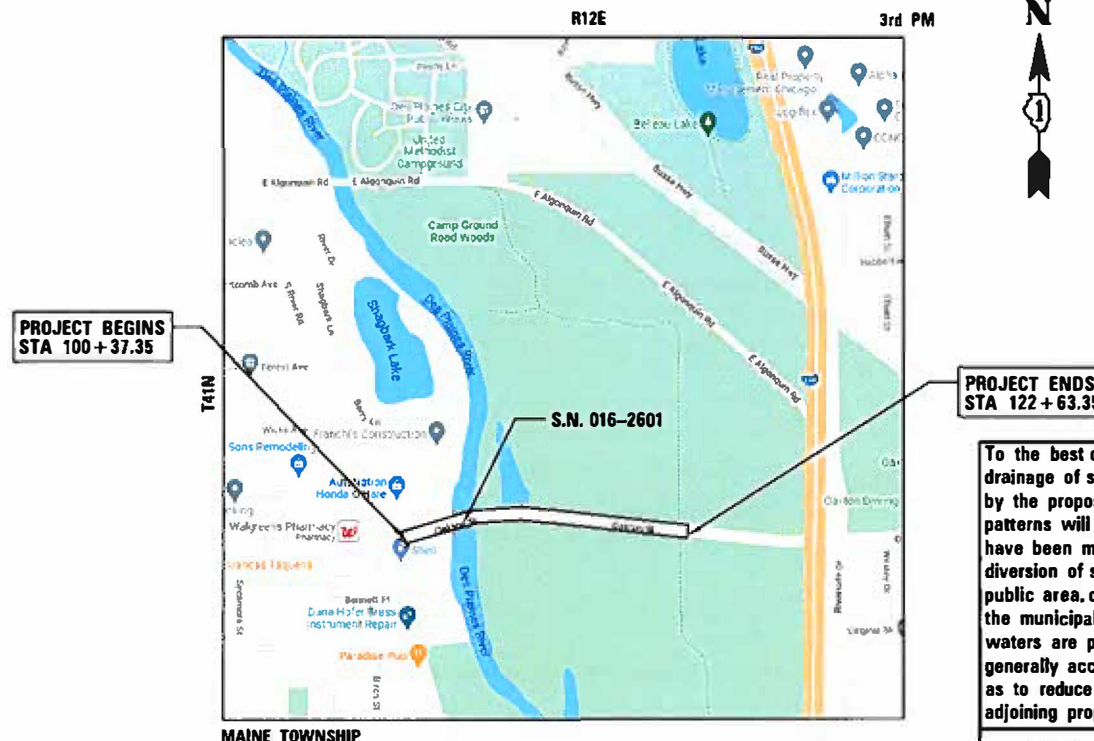

LOCATION MAP
(NOT TO SCALE)

GROSS LENGTH = 2,226 FT. = 0.42 MILE
NET LENGTH = 2,226 FT. = 0.42 MILE

To the best of my knowledge and belief, the drainage of surface waters will not be changed by the proposed development. If any drainage patterns will be changed, reasonable provisions have been made for the collection and diversion of such surface waters into the public area, or drains approved for the use by the municipal engineer, and that such surface waters are planned for in accordance with generally accepted engineering practices so as to reduce the likelihood of damages to adjoining properties.

Mark B. Thomas
ENGINEER
DATE: 11/20/2022
MARK B. THOMAS
ILLINOIS REGISTRATION No. 062-051218
EXPIRATION DATE: 11/30/2023

CB CHRISTOPHER B. BURKE ENGINEERING, LTD.
9575 W. Higgins Road, Suite 600
Rosemont, Illinois 60018
(847) 823-0500

APPROVED: *Timothy P. Oakley*
DIRECTOR OF PUBLIC WORKS AND ENGINEERING
CITY OF DES PLAINES

PASSED: *NOV 7, 2022*
CTP
DISTRICT 1 ENGINEER OF LOCAL ROADS AND STREETS

RELEASED FOR BID
BASED ON LIMITED
REVIEW: *November 7, 2022*
Jose Pires
REGIONAL ENGINEER

**PRINTED BY THE AUTHORITY
OF THE STATE OF ILLINOIS**

GENERAL NOTES

1. ALL CONSTRUCTION SHALL BE DONE IN ACCORDANCE WITH THE "STANDARD SPECIFICATIONS FOR ROAD AND BRIDGE CONSTRUCTION", ADOPTED JANUARY 1, 2022: THE LATEST EDITION OF THE "ILLINOIS MANUAL ON UNIFORM TRAFFIC CONTROL DEVICES FOR STREETS AND HIGHWAYS" (IMUTCD), THE "DETAILS" IN THE PLANS, AND THE "SPECIAL PROVISIONS" INCLUDED IN THE CONTRACT DOCUMENTS.
2. IT IS THE CONTRACTOR'S RESPONSIBILITY TO ASCERTAIN EXISTING FIELD CONDITIONS PRIOR TO BIDDING ON THIS PROJECT. NO ADDITIONAL COMPENSATION WILL BE ALLOWED FOR FAILURE TO VERIFY EXISTING DIMENSIONS OR CONDITIONS.
3. THE CONTRACTOR SHALL LIMIT HIS/HER CONSTRUCTION ACTIVITIES TO THE WORK AREAS DESIGNATED ON THE PLANS. ANY DAMAGE TO AREAS OUTSIDE OF THESE LIMITS SHALL BE REPAIRED BY THE CONTRACTOR AT HIS OWN EXPENSE TO THE SATISFACTION OF THE ENGINEER.
4. THE CONTRACTOR WILL BE REQUIRED TO RELOCATE OR REMOVE AND REPLACE SIGNS WHICH INTERFERE WITH CONSTRUCTION OPERATIONS, AND TO TEMPORARILY RESET ALL SUCH SIGNS DURING CONSTRUCTION OPERATIONS. THIS WORK WILL BE INCLUDED IN THE COST OF THE TRAFFIC CONTROL AND PROTECTION. IF EXISTING SIGNS ARE DAMAGED DURING THE REMOVAL AND REPLACEMENT PROCESS, THE SIGN SHALL BE REPLACED.
5. THE CONTRACTOR SHALL GIVE NOTICES AND COMPLY WITH APPLICABLE LAWS, ORDINANCES, RULES, REGULATIONS AND LAWFUL ORDERS OF ALL PUBLIC AUTHORITIES BEARING ON SAFETY OF PERSONS OR PROPERTY OR THEIR PROTECTION FROM DAMAGE, INJURY OR LOSS.
6. GEOTECHNICAL FABRIC FOR GROUND STABILIZATION AND/OR AGGREGATE SUBGRADE IMPROVEMENT (CU YD) HAVE BEEN PROVIDED FOR USE AT THE LOCATIONS INDICATED FOR SOILS THAT TEND TO BE UNSTABLE AND/OR UNSUITABLE. THE ACTUAL NEED FOR REMOVAL AND REPLACEMENT WITH ABOVE ITEM WILL BE DETERMINED IN THE FIELD AT THE TIME OF CONSTRUCTION BY THE GEOTECHNICAL ENGINEER. ALL POTENTIALLY UNSTABLE SOILS SHOULD BE TESTED WITH A STATIC OR DYNAMIC CONE PENETROMETER AND TREATED IN ACCORDANCE WITH ARTICLE 301.04 OF THE SSRBC AND IDOT SUBGRADE STABILITY MANUAL. IF UNSTABLE AND/OR UNSUITABLE SOILS ARE NOT ENCOUNTERED, THEN THE QUANTITY SHALL BE DEDUCTED AND NO ADDITIONAL COMPENSATION WILL BE DUE TO THE CONTRACTOR.
7. THE SUBGRADE STABILITY SHALL BE VERIFIED BY PROOF ROLLING WITH A FULLY LOADED TANDEM-AXLE TRUCK.
8. THE CONTRACTOR SHALL COORDINATE CONSTRUCTION ACTIVITIES WITH ANY OTHER ROADWAY PROJECTS WITHIN THE AREA THAT ARE UNDER CONSTRUCTION AT THE SAME TIME.
9. THE CONTRACTOR SHALL CONTACT KALPANA KANNAN-HOSADURGA, THE DISTRICT ONE TRAFFIC CONTROL SUPERVISOR, AT KALPANA.KANNAN-HOSADURGA@ILLINOIS.GOV A MINIMUM OF 72 HOURS IN ADVANCE OF BEGINNING WORK.
10. IF ANY EXISTING PAVEMENT MARKINGS AND/OR SIGNING ALONG OAKTON STREET ARE DISTURBED DUE TO THE CONSTRUCTION OF PROPOSED IMPROVEMENTS ALONG OAKTON STREET, THE CONTRACTOR SHALL REPLACE THE DISTURBED TRAFFIC CONTROL DEVICES PER IDOT AND IDOT DISTRICT 1 STANDARDS FOR PAVEMENT MARKING AND SIGNING.
11. THE RESIDENT ENGINEER SHALL CONTACT FADI SULTAN, AREA TRAFFIC FIELD ENGINEER VIA EMAIL AT FADI.SULTAN@ILLINOIS.GOV A MINIMUM OF TWO (2) WEEKS PRIOR TO THE PLACEMENT OF PERMANENT PAVEMENT MARKINGS.
12. CHANGEABLE MESSAGE SIGNS SHALL BE INSTALLED TWO WEEKS PRIOR TO ALL TRAFFIC STAGE CHANGES ON EACH APPROACH OF THE EFFECTED ROADWAY TO WARN MOTORISTS OF THE UPCOMING EVENT. THE SIGNS SHALL BE REMOVED TWO WEEKS THEREAFTER UNLESS THE SIGNS ARE NEEDED AGAIN FOR A FUTURE EVENT THAT WILL OCCUR WITHIN 2 WEEKS ON THE SAME APPROACH OF THE EFFECTED ROADWAY. THE SIGN LOCATIONS SHALL BE DETERMINED BY THE ENGINEER.
13. THE AGGREGATE GRADATION FOR THE AGGREGATE SUBGRADE IMPROVEMENT 12" LOWER LIFT SHALL BE CS 1 OR RR 1.
14. PHOSPHORUS FERTILIZER HAS BEEN INTENTIONALLY OMITTED FROM THE CONTRACT DUE TO THE PROXIMITY TO THE EXISTING WETLANDS. A PHOSPHORUS-FREE FERTILIZER SHALL BE USED (MIDDLE NUMBER SHOULD EQUAL 0).
15. ANY AGGREGATE SUBGRADE IMPROVEMENT CONTAMINATED AND/OR DAMAGED BY THE CONTRACTOR'S VEHICLES AND/OR EQUIPMENTS IS TO BE REMOVED AND REPLACED AS DIRECT BY THE ENGINEER AT CONTRACTOR EXPENSE.
16. PIPE UNDERDRAINS SHALL BE INSTALLED ACCORDING TO SECTION 601 OF THE SSRBC AND STANDARD 601001-05. TOP OF PIPE UNDERDRAINS SHALL BE PLACED MINIMUM 6" BELOW THE AGGREGATE SUBGRADE IMPROVEMENT LAYER. THE COST OF MAKING PIPE UNDERDRAINS CONNECTIONS TO DRAINAGE STRUCTURES SHALL BE INCLUDED IN THE COST OF THE PIPE UNDERDRAINS.
17. **UTILITIES**
 (A) ALL UNDERGROUND UTILITY LOCATIONS, INCLUDING BUT NOT LIMITED TO SANITARY AND STORM SEWERS, WATER MAINS AND THEIR RESPECTIVE SERVICE LINES, SHOWN ON THE PLANS ARE APPROXIMATE ONLY. UNDERGROUND FACILITIES REPRESENTS ONLY THE OPINION OF THE VILLAGE, AS TO THE LOCATION OF SUCH UTILITIES AND IS ONLY INCLUDED FOR THE CONVENIENCE OF THE BIDDER. IT SHALL BE THE CONTRACTOR'S RESPONSIBILITY TO HAVE THE RESPECTIVE UTILITY COMPANIES FIELD LOCATE ALL UTILITIES AS NECESSARY, PRIOR TO STARTING CONSTRUCTION. THE CONTRACTOR SHALL NOTIFY J.U.L.I.E. AT (800) 892-0123, AND ALL PUBLIC AND PRIVATE UTILITIES BEFORE STARTING CONSTRUCTION.
 (B) THE CONTRACTOR SHALL BE RESPONSIBLE FOR THE PROTECTION OF ALL UNDERGROUND OR SURFACE UTILITIES EVEN THOUGH THEY MAY NOT BE SHOWN ON THE PLANS. ANY UTILITY THAT IS DAMAGED DURING CONSTRUCTION SHALL BE REPAIRED OR REPLACED TO THE SATISFACTION OF THE ENGINEER.
18. **STORM SEWER CONSTRUCTION**
 FRAME ELEVATIONS GIVEN ON THE PLANS ARE ONLY TO ASSIST THE CONTRACTOR IN DETERMINING THE APPROXIMATE OVERALL HEIGHT OF THE STRUCTURE. FRAMES OF ALL NEW, ADJUSTED OR RECONSTRUCTED STRUCTURES WILL BE ADJUSTED TO THE FINAL ELEVATION OF THE AREA IN WHICH THEY ARE LOCATED AS PART OF THE STRUCTURE, ADJUSTMENT OR RECONSTRUCTION COST.
19. **SOIL EROSION AND SEDIMENT CONTROL**
 (A) SOIL EROSION AND SEDIMENT CONTROL (SESC) FEATURES MUST BE CONSTRUCTED PRIOR TO THE COMMENCEMENT OF UPLAND DISTURBANCE. SOIL DISTURBANCE MUST BE PHASED OR ENACTED IN SUCH A MANNER AS TO MINIMIZE EROSION. SOIL STABILIZATION MEASURES MUST CONSIDER THE TIME OF YEAR, SITE CONDITIONS AND THE USE OF TEMPORARY AND/OR PERMANENT MEASURES.
 (B) UNLESS OTHERWISE INDICATED, ALL VEGETATIVE AND STRUCTURAL EROSION AND SEDIMENT CONTROL PRACTICES WILL BE INSTALLED AT MINIMUM ACCORDING TO THE STANDARDS AND SPECIFICATIONS IN THE ILLINOIS URBAN MANUAL, REVISED TO LATEST VERSION AS AMENDED. A COPY OF THE APPROVED SOIL EROSION AND SEDIMENT CONTROL (SESC) PLAN AND THE STORM WATER POLLUTION PREVENTION PLAN (SWPPP) MUST BE MAINTAINED ON THE SITE AT ALL TIMES.
 (C) THE EROSION AND SEDIMENT CONTROLS SHOWN ON THE PLANS ARE THE MINIMUM REQUIREMENTS. ADDITIONAL MEASURES MAY BE REQUIRED AS DIRECTED BY THE ENGINEER. ALL ADDITIONAL MEASURES MUST BE IN PLACE WITHIN 3 DAYS OF DISTURBANCE AND ANY EMERGENCY SESC MEASURES MUST BE INSTALLED IMMEDIATELY.
 (D) THE CONTRACTOR MUST CLEAN UP, GRADE THE WORK AREAS AS THE PROJECT PROGRESSES, AND INSTALL TEMPORARY OR PERMANENT EROSION PROTECTION TO CONTROL SOIL EROSION, OR INSTALL APPROPRIATE SEDIMENT CONTROL DEVICES TO TRAP SEDIMENT. PAVEMENT MUST BE CLEANED DAILY OR AS NECESSARY TO REMOVE TRACK-OUT MATERIAL.
 (E) ACCESS TO THE WORK AREA WILL ONLY BE ALLOWED FROM STABILIZED CONSTRUCTION ENTRANCES. ANY SOIL REACHING PUBLIC OR PRIVATE ROADWAYS MUST BE REMOVED IMMEDIATELY.
 (F) DURING DE-WATERING/PUMPING OPERATIONS, ONLY UNCONTAMINATED WATER SHOULD BE ALLOWED TO DISCHARGE TO PROTECTED NATURAL AREAS, WATERS OF THE STATE, OR TO A STORM SEWER SYSTEM (IN ACCORDANCE WITH LOCAL PERMITS). INLET HOSES SHOULD BE FLOATED AT THE SURFACE OF THE WATER IN ORDER TO LIMIT THE AMOUNT OF SEDIMENT INTAKE. PUMPING OPERATIONS MAY BE DISCHARGED TO A STABILIZED AREA THAT CONSISTS OF AN ENERGY DISSIPATING DEVICE (E.G., STONE), SEDIMENT FILTER BAG, OR BOTH. ADEQUATE EROSION AND SEDIMENT CONTROLS SHOULD BE USED DURING DE-WATERING OPERATIONS AS NECESSARY.

DEWATERING SEDIMENT LADEN WATER DIRECTLY INTO FIELD TILES, STORM WATER STRUCTURES, OR "WATERS OF THE US" IS PROHIBITED.

(G) CONSTRUCTION ACTIVITIES MUST BE SCHEDULED TO MINIMIZE THE TIME SOIL IS EXPOSED AND UNPROTECTED. IN NO CASE WILL THE EXISTING VEGETATION BE DESTROYED, REMOVED, OR DISTURBED MORE THAN FOURTEEN (14) DAYS PRIOR TO THE INITIATION OF IMPROVEMENTS.

(H) ALL DISTURBED SOILS ARE TO BE STABILIZED, TEMPORARILY OR PERMANENTLY, WITHIN SEVEN (7) DAYS OF CONSTRUCTION ACTIVITY HAVING CEASED IF THE SOIL IS TO REMAIN UNDISTURBED FOR MORE THAN FOURTEEN (14) DAYS.

HIGHWAY STANDARDS

000001 - 08	STANDARD SYMBOLS, ABBREVIATIONS AND PATTERNS
424001 - 11	PERPENDICULAR CURB RAMPS FOR SIDEWALKS
424011 - 04	CORNER PARALLEL CURB RAMPS FOR SIDEWALKS
601001 - 05	PIPE UNDERDRAINS
601101 - 02	CONCRETE HEADWALL FOR PIPE UNDERDRAINS
606001 - 08	CONCRETE CURB TYPE B AND COMBINATION CONCRETE CURB AND GUTTER
630001 - 12	STEEL PLATE BEAM GUARDRAIL
630116	BACK SIDE PROTECTION OF GUARDRAIL
701101 - 05	OFF-RD OPERATIONS, MULTILANE, 15' (4.5 m) TO 24" (600 mm) FROM PAVEMENT EDGE
701106 - 02	OFF-ROAD OPERATIONS, MULTILANE, MORE THAN 15' (4.5 m) AWAY
701427 - 05	LANE CLOSURE, MULTI-LANE, INTERMITTENT OR MOVING OPER., FOR SPEEDS LESS THAN OR EQUAL TO 40 MPH
701602 - 10	URBAN LANE CLOSURE, MULTILANE, 2W WITH BIDIRECTIONAL LEFT TURN LANE
701606 - 10	URBAN SINGLE LANE CLOSURE, MULTILANE, 2W WITH MOUNTABLE MEDIAN
701611 - 01	URBAN HALF ROAD CLOSURE, MULTILANE, 2W WITH MOUNTABLE MEDIAN
701701 - 10	URBAN LANE CLOSURE, MULTILANE INTERSECTION
701801 - 06	SIDEWALK, CORNER OR CROSSWALK CLOSURE
701901 - 08	TRAFFIC CONTROL DEVICES
704001 - 08	TEMPORARY CONCRETE BARRIER
720001 - 01	SIGN PANEL MOUNTING DETAILS
720006 - 04	SIGN PANEL ERECTION DETAILS
720016 - 04	MAST ARM MOUNTED STREET NAME SIGNS
728001 - 01	TELESCOPING STEEL SIGN SUPPORT
729001 - 01	APPLICATIONS OF TYPES A & B METAL POSTS (FOR SIGNS AND MARKERS)
782006 - 01	GUARDRAIL AND BARRIER WALL REFLECTOR MOUNTING DETAILS
805001 - 01	ELECTRICAL SERVICE INSTALLATION DETAILS
814001 - 03	HANDHOLES
857001 - 01	STANDARD PHASE DESIGNATION DIAGRAMS AND PHASE SEQUENCES
862001 - 01	UNINTERRUPTABLE POWER SUPPLY (UPS)
873001 - 02	TRAFFIC SIGNAL GROUNDING & BONDING
877001 - 08	STEEL MAST ARM ASSEMBLY AND POLE 16' THROUGH 55'
878001 - 11	CONCRETE FOUNDATION DETAILS
880006 - 01	TRAFFIC SIGNAL MOUNTING DETAILS

DISTRICT ONE DETAILS

BD 01	DRIVEWAY DETAILS - DISTANCE BETWEEN R.O.W. AND FACE OF CURB & EDGE OF SHOULDER ≥15'(4.5m)
BD-7	DETAIL OF STORM SEWER CONNECTION TO EXISTING SEWER
BD-32	BUTT JOINT AND HMA TAPER DETAILS
BD 34	DETAILS FOR DEPRESSED CURB & GUTTER AND SHOULDER TREATMENT AT TBT TY. 1 SPL.
BD-51	BENCHING DETAIL FOR EMBANKMENT WIDENING
BD-55	RUMBLE STRIPS FOR CENTERLINE, NON-FREEWAY
TC-10	TRAFFIC CONTROL AND PROTECTION FOR SIDE ROADS, INTERSECTIONS AND DRIVEWAYS
TC-11	TYPICAL APPLICATIONS RAISED REFLECTIVE PAVEMENT MARKERS (SNOW-PLOW RESISTANT)
TC-13	DISTRICT ONE TYPICAL PAVEMENT MARKINGS
TC-14	TRAFFIC CONTROL AND PROTECTION AT TURN BAYS (TO REMAIN OPEN TO TRAFFIC)
TC-16	DISTRICT ONE SHORT TERM PAVEMENT MARKINGS L&S
TC-22	ARTERIAL ROAD INFORMATION SIGN

INDEX OF SHEETS

1	COVER SHEET
2	GENERAL NOTES, INDEX, AND LISTING OF HIGHWAY STANDARDS
3	MWRD GENERAL NOTES
4 - 11	SUMMARY OF QUANTITIES
12-15	TYPICAL SECTIONS
16 - 17	SCHEDULES
18 - 19	ALIGNMENTS, TIES AND BENCHMARKS
20 - 21	EXISTING CONDITIONS AND REMOVAL PLAN
22 - 25	PROPOSED PLAN AND PROFILE
26 - 31	MAINTENANCE OF TRAFFIC
32 - 33	EROSION CONTROL PLAN
34 - 36	PAVEMENT MARKING & LANDSCAPE PLAN
37	DETECTOR LOOP REPLACEMENT PLAN
38	ADA GRADING DETAILS
39 - 48	STRUCTURAL BRIDGE PLANS
49 - 53	STRUCTURAL WALL PLANS
54 - 56	BORING LOGS
57 - 58	CONSTRUCTION DETAILS
59 - 70	DISTRICT ONE DETAILS
71 - 89	CROSS SECTIONS

COMMITMENTS

NONE.

FILE NAME: \\p0138-02_01.SHT	USER NAME: rthomas	DESIGNED: -	REVISED: -	STATE OF ILLINOIS DEPARTMENT OF TRANSPORTATION	OAKTON STREET SIDEPATH INDEX OF SHEETS, HIGHWAY STANDARDS, DISTRICT 1 DETAILS, COMMITMENTS AND GENERAL NOTES.				F.A. RTE.	SECTION 20-00224-00-BT	COUNTY COOK	TOTAL SHEETS 89	SHEET NO. 2
Default	PLOT SCALE: 4#	DRAWN: -	REVISED: -		SCALE: SHEET OF SHEETS STA. TO STA.				CONTRACT NO. 61J19				
	PLOT DATE: 11/8/2022	CHECKED: -	REVISED: -						ILLINOIS FED. AID PROJECT				
		DATE: -	REVISED: -										

MWRD GENERAL NOTES

- A. **REFERENCED SPECIFICATIONS**
- ALL CONSTRUCTION SHALL BE IN ACCORDANCE WITH THE APPLICABLE SECTIONS OF THE FOLLOWING, EXCEPT AS MODIFIED HEREIN OR ON THE PLANS:
 * STANDARD SPECIFICATIONS FOR ROAD AND BRIDGE CONSTRUCTION (JAN 1, 2022), BY THE ILLINOIS DEPARTMENT OF TRANSPORTATION (IDOT SS) FOR ALL IMPROVEMENTS EXCEPT SANITARY SEWER AND WATER MAIN CONSTRUCTION;
 * STANDARD SPECIFICATIONS FOR WATER AND SEWER MAIN CONSTRUCTION IN ILLINOIS, LATEST EDITION (SSWS) FOR SANITARY SEWER AND WATER MAIN CONSTRUCTION;
 * CITY OF DES PLAINES MUNICIPAL CODE;
 * THE METROPOLITAN WATER RECLAMATION DISTRICT OF GREATER CHICAGO (MWRD) WATERSHED MANAGEMENT ORDINANCE AND TECHNICAL GUIDANCE MANUAL;
 * IN CASE OF CONFLICT BETWEEN THE APPLICABLE ORDINANCES NOTED, THE MORE STRINGENT SHALL TAKE PRECEDENCE AND SHALL CONTROL ALL CONSTRUCTION.
- B. **NOTIFICATIONS**
- THE MWRD LOCAL SEWER SYSTEMS SECTION FIELD OFFICE MUST BE NOTIFIED AT LEAST TWO (2) WORKING DAYS PRIOR TO THE COMMENCEMENT OF ANY WORK (CALL 708-588-4055).
 - THE CITY OF DES PLAINES ENGINEERING DEPARTMENT AND PUBLIC MUST BE NOTIFIED AT LEAST 24 HOURS PRIOR TO THE START OF CONSTRUCTION AND PRIOR TO EACH PHASE OF WORK. CONTRACTOR SHALL DETERMINE ITEMS REQUIRING INSPECTION PRIOR TO START OF CONSTRUCTION OR EACH WORK PHASE.
- C. **GENERAL NOTES**
- ALL ELEVATIONS SHOWN ON PLANS REFERENCE THE NORTH AMERICAN VERTICAL DATUM OF 1988 (NAVD88).
 - THE ENGINEER, IN COORDINATION WITH THE MWRD, THE MUNICIPALITY AND THE OWNER OR OWNER'S REPRESENTATIVE SHALL HAVE THE AUTHORITY TO INSPECT, APPROVE, AND REJECT THE CONSTRUCTION IMPROVEMENTS.
 - THE CONTRACTOR(S) SHALL INDEMNIFY THE OWNER, ENGINEER, MUNICIPALITY, MWRD, AND THEIR AGENTS, ETC., FROM ALL LIABILITY INVOLVED WITH THE CONSTRUCTION, INSTALLATION, OR TESTING OF THIS WORK ON THE PROJECT.
 - THE PROPOSED IMPROVEMENTS MUST BE CONSTRUCTED IN ACCORDANCE WITH THE ENGINEERING PLANS AS APPROVED BY MWRD AND THE MUNICIPALITY UNLESS CHANGES ARE APPROVED BY MWRD, THE MUNICIPALITY, OR AUTHORIZED AGENT. THE CONSTRUCTION DETAILS, AS PRESENTED ON THE PLANS, MUST BE FOLLOWED. PROPER CONSTRUCTION TECHNIQUES MUST BE FOLLOWED ON THE IMPROVEMENTS INDICATED ON THE PLANS.
 - THE UNDERGROUND CONTRACTOR SHALL MAKE ALL NECESSARY ARRANGEMENTS TO NOTIFY ALL INSPECTION AGENCIES.
 - ALL NEW AND EXISTING UTILITY STRUCTURES ON SITE AND IN AREAS DISTURBED DURING CONSTRUCTION SHALL BE ADJUSTED TO FINISH GRADE PRIOR TO FINAL INSPECTION.
 - RECORD DRAWINGS SHALL BE KEPT BY THE CONTRACTOR AND SUBMITTED TO THE ENGINEER AS SOON AS UNDERGROUND IMPROVEMENTS ARE COMPLETED. FINAL PAYMENTS TO THE CONTRACTOR SHALL BE HELD UNTIL THEY ARE RECEIVED. ANY CHANGES IN LENGTH, LOCATION OR ALIGNMENT SHALL BE SHOWN IN RED. ALL WYES OR BENDS SHALL BE LOCATED FROM THE DOWNSTREAM MANHOLE. ALL VALVES, B-BOXES, TEES OR BENDS SHALL BE TIED TO A FIRE HYDRANT.
- D. **SANITARY SEWER**
- THE CONTRACTOR SHALL TAKE MEASURES TO PREVENT ANY POLLUTED WATER, SUCH AS GROUND AND SURFACE WATER, FROM ENTERING THE EXISTING SANITARY SEWERS.
 - A WATER-TIGHT PLUG SHALL BE INSTALLED IN THE DOWNSTREAM SEWER PIPE AT THE POINT OF SEWER CONNECTION PRIOR TO COMMENCING ANY SEWER CONSTRUCTION. THE PLUG SHALL REMAIN IN PLACE UNTIL REMOVAL IS AUTHORIZED BY THE MUNICIPALITY AND/OR MWRD AFTER THE SEWERS HAVE BEEN TESTED AND ACCEPTED.
 - DISCHARGING ANY UNPOLLUTED WATER INTO THE SANITARY SEWER SYSTEM FOR THE PURPOSE OF SEWER FLUSHING OF LINES FOR THE DEFLECTION TEST SHALL BE PROHIBITED WITHOUT PRIOR APPROVAL FROM THE ENGINEER IN COORDINATION WITH DES PLAINES AND/OR MWRD.
 - ALL SANITARY SEWER CONSTRUCTION SHALL BE IN ACCORDANCE WITH THE STANDARD SPECIFICATIONS FOR WATER AND SEWER MAIN CONSTRUCTION IN ILLINOIS (LATEST EDITION).
 - ALL FLOOR DRAINS SHALL DISCHARGE TO THE SANITARY SEWER SYSTEM.
 - ALL DOWNSPOUTS AND FOOTING DRAINS SHALL DISCHARGE TO THE STORM SEWER SYSTEM.

- ALL SANITARY SEWER PIPE MATERIALS AND JOINTS (AND STORM SEWER PIPE MATERIALS AND JOINTS IN A COMBINED SEWER AREA) SHALL CONFORM TO THE FOLLOWING:

PIPE MATERIAL	PIPE SPECS	JOINT SPECS
VITRIFIED CLAY PIPE	ASTM C-700	ASTM C-425
REINFORCED CONCRETE SEWER PIPE	ASTM C-76	ASTM C-443
CAST IRON SOIL PIPE	ASTM A-74	ASTM C-564
DUCTILE IRON PIPE	AANSI A21.51	ANSI A21.11
POLYVINYL CHLORIDE (PVC) PIPE		
6-INCH TO 15-INCH DIAMETER SDR 26	ASTM D-3034	ASTM D-3212
18-INCH TO 27-INCH DIAMETER F/DY=46	ASTM F-679	ASTM D-3212
HIGH DENSITY POLYETHYLENE (HDPE)	ASTM D-3350	ASTM D-3261, F-2620 (HEAT FUSION)
	ASTM-3035	ASTM D-3212, F-477 (GASKETED)
WATER MAIN QUALITY PVC		
4-INCH TO 36-INCH	ASTM D-2241	ASTM D-3139
4-INCH TO 12-INCH	AWWA C900	ASTM D-3139
14-INCH TO 48-INCH	AWWA C905	ASTM D-3139

THE FOLLOWING MATERIALS ARE ALLOWED ON A QUALIFIED BASIS SUBJECT TO DISTRICT REVIEW AND APPROVAL PRIOR TO PERMIT ISSUANCE. A SPECIAL CONDITION WILL BE ADDED TO THE PERMIT WHEN THE PIPE MATERIAL BELOW IS USED FOR SEWER CONSTRUCTION OR A CONNECTION IS MADE.

PIPE MATERIAL	PIPE SPECS	JOINT SPECS
POLYPROPYLENE (PP) PIPE		
12-INCH TO 24-INCH DOUBLE WALL	ASTM F-2736	D-3212, F-477
30 INCH TO 60-INCH TRIPLE WALL	ASTM F-2764	D3212, F-477

- ALL SANITARY SEWER CONSTRUCTION (AND STORM SEWER CONSTRUCTION IN COMBINED SEWER AREAS), REQUIRES STONE BEDDING WITH STONE ¾" TO 1" IN SIZE, WITH MINIMUM BEDDING THICKNESS EQUAL TO ¼ THE OUTSIDE DIAMETER OF THE SEWER PIPE, BUT NOT LESS THAN FOUR (4) INCHES NOR MORE THAN EIGHT (8) INCHES. MATERIAL SHALL BE CA-7, CA-11 OR CA-13 AND SHALL BE EXTENDED AT LEAST 12" ABOVE THE TOP OF THE PIPE WHEN USING PVC.
- NON-SHEAR FLEXIBLE-TYPE COUPLINGS SHALL BE USED IN THE CONNECTION OF SEWER PIPES OF DISSIMILAR PIPE MATERIALS.
- ALL MANHOLES SHALL BE PROVIDED WITH BOLTED, WATERTIGHT COVERS. SANITARY LIDS SHALL BE CONSTRUCTED WITH A CONCEALED PICKHOLE AND WATERTIGHT GASKET WITH THE WORD "SANITARY" CAST INTO THE LID.
- WHEN CONNECTING TO AN EXISTING SEWER MAIN BY MEANS OTHER THAN AN EXISTING WYE, TEE, OR AN EXISTING MANHOLE, ONE OF THE FOLLOWING METHODS SHALL BE USED:
 - A CIRCULAR SAW-CUT OF SEWER MAIN BY PROPER TOOLS AND PROPER INSTALLATION OF HUBWYE SADDLE OR HUB-TEE SADDLE.
 - REMOVE AN ENTIRE SECTION OF PIPE (BREAKING ONLY THE TOP OF ONE BELL) AND REPLACE WITH A WYE OR TEE BRANCH SECTION.
 - WITH PIPE CUTTER, NEATLY AND ACCURATELY CUT OUT DESIRED LENGTH OF PIPE FOR INSERTION OF PROPER FITTING, USING COUPLINGS TO HOLD IT FIRMLY IN PLACE.
- WHENEVER A SANITARY/COMBINED SEWER CROSSES UNDER A WATERMAIN, THE MINIMUM VERTICAL DISTANCE FROM THE TOP OF THE SEWER TO THE BOTTOM OF THE WATERMAIN SHALL BE 18 INCHES. FURTHERMORE, A MINIMUM HORIZONTAL DISTANCE OF 10 FEET BETWEEN SANITARY/COMBINED SEWERS AND WATERMANS SHALL BE MAINTAINED UNLESS: THE SEWER IS LAID IN A SEPARATE TRENCH, KEEPING A MINIMUM 18" VERTICAL SEPARATION; OR THE SEWER IS LAID IN THE SAME TRENCH WITH THE WATERMAIN LOCATED AT THE OPPOSITE SIDE ON A BENCH OF UNDISTURBED EARTH, KEEPING A MINIMUM 18" VERTICAL SEPARATION. IF EITHER THE VERTICAL OR HORIZONTAL DISTANCES DESCRIBED CANNOT BE MAINTAINED, OR THE SEWER CROSSES ABOVE THE WATER MAIN, THE SEWER SHALL BE CONSTRUCTED TO WATER MAIN STANDARDS OR IT SHALL BE ENCASED WITH A WATER MAIN QUALITY CARRIER PIPE WITH THE ENDS SEALED.
- ALL EXISTING SEPTIC SYSTEMS SHALL BE ABANDONED. ABANDONED TANKS SHALL BE FILLED WITH GRANULAR MATERIAL OR REMOVED.
- ALL SANITARY MANHOLES, (AND STORM MANHOLES IN COMBINED SEWER AREAS), SHALL HAVE A MINIMUM INSIDE DIAMETER OF 48 INCHES, AND SHALL BE CAST IN PLACE OR PRE-CAST REINFORCED CONCRETE.
- ALL SANITARY MANHOLES, (AND STORM MANHOLES IN COMBINED SEWER AREAS), SHALL HAVE PRECAST "RUBBER BOOTS" THAT CONFORM TO ASTM C-923 FOR ALL PIPE CONNECTIONS. PRECAST SECTIONS SHALL CONSIST OF MODIFIED GROOVE TONGUE AND RUBBER GASKET TYPE JOINTS.

- ALL ABANDONED SANITARY SEWERS SHALL BE PLUGGED AT BOTH ENDS WITH AT LEAST 2 FEET LONG NON-SHRINK CONCRETE OR MORTAR PLUG.
 - EXCEPT FOR FOUNDATION/FOOTING DRAINS PROVIDED TO PROTECT BUILDINGS, OR PERFORATED PIPES ASSOCIATED WITH VOLUME CONTROL FACILITIES, DRAIN TILES/FIELD TILES/UNDERDRAINS/PERFORATED PIPES ARE NOT ALLOWED TO BE CONNECTED TO OR TRIBUTARY TO COMBINED SEWERS, SANITARY SEWERS, OR STORM SEWERS TRIBUTARY TO COMBINED SEWERS IN COMBINED SEWER AREAS. CONSTRUCTION OF NEW FACILITIES OF THIS TYPE IS PROHIBITED; AND ALL EXISTING DRAIN TILES AND PERFORATED PIPES ENCOUNTERED WITHIN THE PROJECT AREA SHALL BE PLUGGED OR REMOVED, AND SHALL NOT BE CONNECTED TO COMBINED SEWERS, SANITARY SEWERS, OR STORM SEWERS TRIBUTARY TO COMBINED SEWERS.
 - A BACKFLOW PREVENTER IS REQUIRED FOR ALL DETENTION BASINS TRIBUTARY TO COMBINED SEWERS. REQUIRED BACKFLOW PREVENTERS SHALL BE INSPECTED AND EXERCISED ANNUALLY BY THE PROPERTY OWNER TO ENSURE PROPER OPERATION, AND ANY NECESSARY MAINTENANCES SHALL BE PERFORMED TO ENSURE FUNCTIONALITY. IN THE EVENT OF A SEWER SURCHARGE INTO AN OPEN DETENTION BASIN TRIBUTARY TO COMBINED SEWERS, THE PERMITTEE SHALL ENSURE THAT CLEAN UP AND WASH OUT OF SEWAGE TAKES PLACE WITHIN 48 HOURS OF THE STORM EVENT.
- E. **SOIL EROSION AND SEDIMENT CONTROL PLAN**
- CONTRACTOR SHALL INSTALL INLET PROTECTION FOR ALL STRUCTURES WITHIN THE PROPOSED LIMITS OF DISTURBANCE.
 - THE CONTRACTOR SHALL INSTALL THE EROSION AND SEDIMENT CONTROL DEVICES AS SHOWN ON THE APPROVED EROSION AND SEDIMENT CONTROL PLAN. EROSION AND SEDIMENT CONTROL PRACTICES SHALL BE FUNCTIONAL PRIOR TO HYDROLOGIC DISTURBANCE OF THE SITE.
 - ALL DESIGN CRITERIA, SPECIFICATIONS, AND INSTALLATION OF EROSION AND SEDIMENT CONTROL PRACTICES SHALL BE IN ACCORDANCE WITH THE ILLINOIS URBAN MANUAL.
 - A COPY OF THE APPROVED EROSION AND SEDIMENT CONTROL PLAN SHALL BE MAINTAINED ON THE SITE AT ALL TIMES.
 - INSPECTIONS AND DOCUMENTATION SHALL BE PERFORMED, AT A MINIMUM:
 - UPON COMPLETION OF INITIAL EROSION AND SEDIMENT CONTROL MEASURES, PRIOR TO ANY SOIL DISTURBANCE.
 - ONCE EVERY SEVEN (7) CALENDAR DAYS AND WITHIN 24 HOURS OF THE END OF A STORM EVENT WITH GREATER THAN 0.5 INCH OF RAINFALL OR LIQUID EQUIVALENT PRECIPITATION.
 - SOIL DISTURBANCE SHALL BE CONDUCTED IN SUCH A MANNER AS TO MINIMIZE EROSION. IF STRIPPING, CLEARING, GRADING, OR LANDSCAPING ARE TO BE DONE IN PHASES, THE CO-PERMITTEE SHALL PLAN FOR APPROPRIATE SOIL EROSION AND SEDIMENT CONTROL MEASURES.
 - A STABILIZED MAT OF CRUSHED STONE MEETING THE STANDARDS OF THE ILLINOIS URBAN MANUAL SHALL BE INSTALLED AT ANY POINT WHERE TRAFFIC WILL BE ENTERING OR LEAVING A CONSTRUCTION SITE. SEDIMENT OR SOIL REACHING AN IMPROVED PUBLIC RIGHT-OF-WAY, STREET, ALLEY OR PARKING AREA SHALL BE REMOVED BY SCRAPING OR STREET CLEANING AS ACCUMULATIONS WARRANT AND TRANSPORTED TO A CONTROLLED SEDIMENT DISPOSAL AREA.
 - CONCRETE WASHOUT FACILITIES SHALL BE CONSTRUCTED IN ACCORDANCE WITH THE ILLINOIS URBAN MANUAL AND SHALL BE INSTALLED PRIOR TO ANY ON SITE CONSTRUCTION ACTIVITIES INVOLVING CONCRETE.
 - MORTAR WASHOUT FACILITIES SHALL BE CONSTRUCTED IN ADDITION TO CONCRETE WASHOUT FACILITIES FOR ANY BRICK AND MORTAR BUILDING ENVELOPE CONSTRUCTION ACTIVITIES.
 - TEMPORARY DIVERSIONS SHALL BE CONSTRUCTED AS NECESSARY TO DIRECT ALL RUNOFF FROM HYDROLOGICALLY DISTURBED AREAS TO AN APPROPRIATE SEDIMENT TRAP OR BASIN. VOLUME CONTROL FACILITIES SHALL NOT BE USED AS TEMPORARY SEDIMENT BASINS.
 - DISTURBED AREAS OF THE SITE WHERE CONSTRUCTION ACTIVITIES HAVE TEMPORARILY OR PERMANENTLY CEASED SHALL BE STABILIZED WITH TEMPORARY OR PERMANENT MEASURES WITHIN SEVEN (7) DAYS.
 - ALL FLOOD PROTECTION AREAS AND VOLUME CONTROL FACILITIES SHALL, AT A MINIMUM, BE PROTECTED WITH A DOUBLE-ROW OF SILT FENCE (OR EQUIVALENT).
 - VOLUME CONTROL FACILITIES SHALL NOT BE CONSTRUCTED UNTIL ALL OF THE CONTRIBUTING DRAINAGE AREA HAS BEEN STABILIZED.
 - SOIL STOCKPILES SHALL, AT A MINIMUM, BE PROTECTED WITH PERIMETER SEDIMENT CONTROLS. SOIL STOCKPILES SHALL NOT BE PLACED IN FLOOD PROTECTION AREAS OR THEIR BUFFERS.
 - EARTHEN EMBANKMENT SIDE SLOPES SHALL BE STABILIZED WITH APPROPRIATE EROSION CONTROL BLANKET.
 - STORM SEWERS THAT ARE OR WILL BE FUNCTIONING DURING CONSTRUCTION SHALL BE PROTECTED BY APPROPRIATE SEDIMENT CONTROL MEASURES.
 - THE CONTRACTOR SHALL EITHER REMOVE OR REPLACE ANY EXISTING DRAIN TILES AND INCORPORATE THEM INTO THE DRAINAGE PLAN FOR THE DEVELOPMENT. DRAIN TILES CANNOT BE TRIBUTARY TO A SANITARY OR COMBINED SEWER.

- DRAIN TILES ALLOWED IN COMBINED SEWER AREA FOR GREEN INFRASTRUCTURE PRACTICES.
- IF DEWATERING SERVICES ARE USED, ADJOINING PROPERTIES AND DISCHARGE LOCATIONS SHALL BE PROTECTED FROM EROSION AND SEDIMENTATION. DEWATERING SYSTEMS SHOULD BE INSPECTED DAILY DURING OPERATIONAL PERIODS. THE SITE INSPECTOR MUST BE PRESENT AT THE COMMENCEMENT OF DEWATERING ACTIVITIES.
- THE CONTRACTOR SHALL BE RESPONSIBLE FOR TRENCH DEWATERING AND EXCAVATION FOR THE INSTALLATION OF SANITARY SEWERS, STORM SEWERS, WATERMANS AS WELL AS THEIR SERVICES AND OTHER APPURTENANCES. ANY TRENCH DEWATERING, WHICH CONTAINS SEDIMENT SHALL PASS THROUGH A SEDIMENT SETTLING POND OR EQUALLY EFFECTIVE SEDIMENT CONTROL DEVICE. ALTERNATIVES MAY INCLUDE DEWATERING INTO A SUMP PIT, FILTER BAG OR EXISTING VEGETATED UPSLOPE AREA. SEDIMENT LADEN WATERS SHALL NOT BE DISCHARGE TO WATERWAYS, FLOOD PROTECTION AREAS OR THE COMBINED SEWER SYSTEM.
- ALL PERMANENT EROSION CONTROL PRACTICES SHALL BE INITIATED WITHIN SEVEN (7) DAYS FOLLOWING THE COMPLETION OF SOIL DISTURBING ACTIVITIES.
- ALL EROSION AND SEDIMENT CONTROL MEASURES SHALL BE MAINTAINED AND REPAIRED AS NEEDED ON A YEAR-ROUND BASIS DURING CONSTRUCTION AND ANY PERIODS OF CONSTRUCTION SHUTDOWN UNTIL PERMANENT STABILIZATION IS ACHIEVED.
- ALL TEMPORARY EROSION AND SEDIMENT CONTROL MEASURES SHALL BE REMOVED WITHIN THIRTY (30) DAYS AFTER PERMANENT SITE STABILIZATION.
- THE EROSION AND SEDIMENT CONTROL MEASURES SHOWN ON THE PLANS ARE THE MINIMUM REQUIREMENTS. ADDITIONAL MEASURES MAY BE REQUIRED, AS DIRECTED BY THE ENGINEER, SITE INSPECTOR, OR MWRD.

FILE NAME =	USER NAME = mthomas	DESIGNED -	REVISED -	STATE OF ILLINOIS DEPARTMENT OF TRANSPORTATION	OAKTON STREET SIDEPATH MWRD GENERAL NOTES				F.A. RTE.	SECTION	COUNTY	TOTAL SHEETS	SHEET NO.
N:\DESPLAINES\190138.00003\Civil\NOT_OAK	ON_19138-03_01.SHT	DRAWN -	REVISED -							20-00224-00-BT	COOK	89	3
Default	PLOT SCALE = 48'	CHECKED -	REVISED -						CONTRACT NO. 61J19				
	PLOT DATE = 11/8/2022	DATE -	REVISED -						SCALE:	SHEET	OF	SHEETS	STA.

CONSTRUCTION CODE ITEP FUNDS 80% FEDS / 20% STATE

SPECIALTY	SPECIAL PROVISION	CODED PAY ITEM NO.	ITEM	UNIT	TOTAL QUANTITY	FACILITIES FOR BICYCLE/PEDESTRIAN TRAILS 0028 URBAN	TRAINEES 0042 URBAN
		20101100	TREE TRUNK PROTECTION	EACH	14	14	
X		20101200	TREE ROOT PRUNING	EACH	14	14	
X		20101300	TREE PRUNING (1 TO 10 INCH DIAMETER)	EACH	11	11	
X		20101350	TREE PRUNING (OVER 10 INCH DIAMETER)	EACH	3	3	
	*	20200100	EARTH EXCAVATION	CU YD	665	665	
		20201200	REMOVAL AND DISPOSAL OF UNSUITABLE MATERIAL	CU YD	475	475	
		20800150	TRENCH BACKFILL	CU YD	149	149	
		20900110	POROUS GRANULAR BACKFILL	CU YD	70	70	
		21001000	GEOTECHNICAL FABRIC FOR GROUND STABILIZATION	SQ YD	100	100	
		21101615	TOPSOIL FURNISH AND PLACE, 4"	SQ YD	1612	1612	
X		25000210	SEEDING, CLASS 2A	ACRE	0.50	0.50	
X		25000300	SEEDING, CLASS 3	ACRE	0.25	0.25	
X		25000350	SEEDING, CLASS 7	ACRE	0.50	0.50	
X		25000400	NITROGEN FERTILIZER NUTRIENT	POUND	32	32	
X		25000600	POTASSIUM FERTILIZER NUTRIENT	POUND	32	32	
		28000400	PERIMETER EROSION BARRIER	FOOT	2558	2558	

CONSTRUCTION CODE ITEP FUNDS 80% FEDS / 20% STATE

SPECIALTY	SPECIAL PROVISION	CODED PAY ITEM NO.	ITEM	UNIT	TOTAL QUANTITY	FACILITIES FOR BICYCLE/PEDESTRIAN TRAILS 0028 URBAN	TRAINEES 0042 URBAN
		28000510	INLET FILTERS	EACH	66	66	
		28001100	TEMPORARY EROSION CONTROL BLANKET	SQ YD	1151	1151	
		28001200	TEMPORARY HEAVY DUTY EROSION CONTROL BLANKET	SQ YD	311	311	
	*	30300001	AGGREGATE SUBGRADE IMPROVEMENT	CU YD	50	50	
	*	30300112	AGGREGATE SUBGRADE IMPROVEMENT 12"	SQ YD	1007	1007	
		35101600	AGGREGATE BASE COURSE, TYPE B 4"	SQ YD	1057	1057	
		35101800	AGGREGATE BASE COURSE, TYPE B 6"	SQ YD	1359	1359	
		40600275	BITUMINOUS MATERIALS (PRIME COAT)	POUND	2564	2564	
		40600290	BITUMINOUS MATERIALS (TACK COAT)	POUND	7521	7521	
		40600370	LONGITUDINAL JOINT SEALANT	FOOT	6513	6513	
		40600982	HOT-MIX ASPHALT SURFACE REMOVAL - BUTT JOINT	SQ YD	113	113	
	*	40603085	HOT-MIX ASPHALT BINDER COURSE, IL-19.0, N70	TON	37	37	
	*	40603200	POLYMERIZED HOT-MIX ASPHALT BINDER COURSE, IL-4.75, N50	TON	468	468	
	*	40604060	HOT-MIX ASPHALT SURFACE COURSE, IL-9.5, MIX "D", N50	TON	192	192	
	*	40604062	HOT-MIX ASPHALT SURFACE COURSE, IL-9.5, MIX "D", N70	TON	936	936	
		42000060	WELDED WIRE REINFORCEMENT	SQ YD	269	269	

CONSTRUCTION CODE ITEP FUNDS 80% FEDS / 20% STATE

SPECIALTY	SPECIAL PROVISION	CODED PAY ITEM NO.	ITEM	UNIT	TOTAL QUANTITY	CONSTRUCTION CODE ITEP FUNDS 80% FEDS / 20% STATE	
						FACILITIES FOR BICYCLE/PEDESTRIAN TRAILS 0028 URBAN	TRAINEES 0042 URBAN
		42001300	PROTECTIVE COAT	SQ YD	1830	1830	
		42300400	PORTLAND CEMENT CONCRETE DRIVEWAY PAVEMENT, 8 INCH	SQ YD	109	109	
		42400200	PORTLAND CEMENT CONCRETE SIDEWALK 5 INCH	SQ FT	1497	1497	
		42400800	DETECTABLE WARNINGS	SQ FT	80	80	
		44000100	PAVEMENT REMOVAL	SQ YD	817	817	
		44000158	HOT-MIX ASPHALT SURFACE REMOVAL, 2 1/4"	SQ YD	11141	11141	
		44000200	DRIVEWAY PAVEMENT REMOVAL	SQ YD	52	52	
		44000500	COMBINATION CURB AND GUTTER REMOVAL	FOOT	1920	1920	
		44000600	SIDEWALK REMOVAL	SQ FT	2563	2563	
		48203009	HOT-MIX ASPHALT SHOULDERS, 3"	SQ YD	102	102	
		50102400	CONCRETE REMOVAL	CU YD	48.2	48.2	
		50104000	BRIDGE RAIL REMOVAL	FOOT	199	199	
		50200100	STRUCTURE EXCAVATION	CU YD	185	185	
		50300225	CONCRETE STRUCTURES	CU YD	300.6	300.6	
		50300255	CONCRETE SUPERSTRUCTURE	CU YD	88.0	88.0	
		50300300	PROTECTIVE COAT	SQ YD	587	587	

CONSTRUCTION CODE ITEP FUNDS 80% FEDS / 20% STATE

SPECIALTY	SPECIAL PROVISION	CODED PAY ITEM NO.	ITEM	UNIT	TOTAL QUANTITY	FACILITIES FOR BICYCLE/PEDESTRIAN TRAILS 0028 URBAN	TRAINEES 0042 URBAN
		50301350	CONCRETE SUPERSTRUCTURE (APPROACH SLAB)	CU YD	45.2	45.2	
		50800205	REINFORCEMENT BARS, EPOXY COATED	POUND	41910	41910	
X		50901720	BICYCLE RAILING	FOOT	879	879	
X		50901750	PARAPET RAILING	FOOT	264	264	
		52000110	PREFORMED JOINT STRIP SEAL	FOOT	25	25	
		52200015	PERMANENT SHEET PILING	SQ FT	10140	10140	
		550A0050	STORM SEWERS, CLASS A, TYPE 1 12"	FOOT	71	71	
		550A0340	STORM SEWERS, CLASS A, TYPE 2 12"	FOOT	192	192	
		55100500	STORM SEWER REMOVAL 12"	FOOT	328	328	
		60108204	PIPE UNDERDRAINS, TYPE 2, 4"	FOOT	557	557	
		60201330	CATCH BASINS, TYPE A, 4'-DIAMETER, TYPE 23 FRAME AND GRATE	EACH	11	11	
		60205030	CATCH BASINS, TYPE A, 5'-DIAMETER, TYPE 23 FRAME AND GRATE	EACH	4	4	
		60207605	CATCH BASINS, TYPE C, TYPE 8 GRATE	EACH	1	1	
		60208230	CATCH BASINS, TYPE C, TYPE 23 FRAME AND GRATE	EACH	2	2	
		60208240	CATCH BASINS, TYPE C, TYPE 24 FRAME AND GRATE	EACH	2	2	
		60250200	CATCH BASINS TO BE ADJUSTED	EACH	3	3	

CONSTRUCTION CODE ITEP FUNDS 80% FEDS
/ 20% STATE

SPECIALTY	SPECIAL PROVISION	CODED PAY ITEM NO.	ITEM	UNIT	TOTAL QUANTITY	FACILITIES FOR BICYCLE/PEDESTRIAN TRAILS 0028 URBAN	TRAINEES 0042 URBAN
		60255500	MANHOLES TO BE ADJUSTED	EACH	3	3	
		60500050	REMOVING CATCH BASINS	EACH	17	17	
		60603800	COMBINATION CONCRETE CURB AND GUTTER, TYPE B-6.12	FOOT	1910	1910	
		60605000	COMBINATION CONCRETE CURB AND GUTTER, TYPE B-6.24	FOOT	401	401	
		60618300	CONCRETE MEDIAN SURFACE, 4 INCH	SQ FT	1054	1054	
X		63000001	STEEL PLATE BEAM GUARDRAIL, TYPE A, 6 FOOT POSTS	FOOT	175	175	
X		63000035	BACK SIDE PROTECTION OF GUARDRAIL	FOOT	183	183	
X		63100085	TRAFFIC BARRIER TERMINAL, TYPE 6	EACH	1	1	
X		63100167	TRAFFIC BARRIER TERMINAL, TYPE 1 (SPECIAL) TANGENT	EACH	1	1	
		63200310	GUARDRAIL REMOVAL	FOOT	683	683	
X		66900200	NON-SPECIAL WASTE DISPOSAL	CU YD	1215	1215	
X		66900530	SOIL DISPOSAL ANALYSIS	EACH	6	6	
X		66901001	REGULATED SUBSTANCES PRE-CONSTRUCTION PLAN	L SUM	1	1	
X		66901003	REGULATED SUBSTANCES FINAL CONSTRUCTION REPORT	L SUM	1	1	
X		66901006	REGULATED SUBSTANCES MONITORING	CAL DA	14	14	
		67100100	MOBILIZATION	L SUM	1	1	

CONSTRUCTION CODE ITEP FUNDS 80% FEDS
/ 20% STATE

SPECIALTY	SPECIAL PROVISION	CODED PAY ITEM NO.	ITEM	UNIT	TOTAL QUANTITY	FACILITIES FOR BICYCLE/PEDESTRIAN TRAILS	
						0028 URBAN	TRANEES 0042 URBAN
		70103815	TRAFFIC CONTROL SURVEILLANCE	CAL DA	10	10	
		70107025	CHANGEABLE MESSAGE SIGN	CAL DA	42	42	
		70300100	SHORT TERM PAVEMENT MARKING	FOOT	5650	5650	
		70300150	SHORT TERM PAVEMENT MARKING REMOVAL	SQ FT	1890	1890	
		70307100	TEMPORARY PAVEMENT MARKING LETTERS AND SYMBOLS - TYPE IV TAPE	SQ FT	73	73	
		70307120	TEMPORARY PAVEMENT MARKING - LINE 4" - TYPE IV TAPE	FOOT	15878	15878	
		70307130	TEMPORARY PAVEMENT MARKING - LINE 6" - TYPE IV TAPE	FOOT	310	310	
		70307210	TEMPORARY PAVEMENT MARKING - LINE 24" - TYPE IV TAPE	FOOT	48	48	
		70400100	TEMPORARY CONCRETE BARRIER	FOOT	375	375	
		70600240	IMPACT ATTENUATORS, TEMPORARY (NON- REDIRECTIVE), TEST LEVEL 2	EACH	1	1	
X		72000100	SIGN PANEL - TYPE 1	SQ FT	100	100	
X		72400310	REMOVE SIGN PANEL - TYPE 1	SQ FT	32	32	
X		72501000	TERMINAL MARKER - DIRECT APPLIED	EACH	1	1	
X		72800100	TELESCOPING STEEL SIGN SUPPORT	FOOT	124	124	
X		78000100	THERMOPLASTIC PAVEMENT MARKING - LETTERS AND SYMBOLS	SQ FT	73	73	
X		78000200	THERMOPLASTIC PAVEMENT MARKING - LINE 4"	FOOT	9732	9732	

CONSTRUCTION CODE ITEP FUNDS 80% FEDS / 20% STATE

SPECIALTY	SPECIAL PROVISION	CODED PAY ITEM NO.	ITEM	UNIT	TOTAL QUANTITY	FACILITIES FOR	
						BICYCLE/PEDESTRIAN TRAILS 0028 URBAN	TRAINEES 0042 URBAN
X		78000400	THERMOPLASTIC PAVEMENT MARKING - LINE 6"	FOOT	365	365	
X		78000600	THERMOPLASTIC PAVEMENT MARKING - LINE 12"	FOOT	289	289	
X		78000650	THERMOPLASTIC PAVEMENT MARKING - LINE 24"	FOOT	46	46	
X		78004620	PREFORMED PLASTIC PAVEMENT MARKING, TYPE D - LINE 4"	FOOT	227	227	
X		78009000	MODIFIED URETHANE PAVEMENT MARKING - LETTERS AND SYMBOLS	SQ FT	37	37	
X		78009004	MODIFIED URETHANE PAVEMENT MARKING - LINE 4"	FOOT	1168	1168	
X		78009006	MODIFIED URETHANE PAVEMENT MARKING - LINE 6"	FOOT	49	49	
X		78009012	MODIFIED URETHANE PAVEMENT MARKING - LINE 12"	FOOT	113	113	
X		78009024	MODIFIED URETHANE PAVEMENT MARKING - LINE 24"	FOOT	48	48	
X		78100100	RAISED REFLECTIVE PAVEMENT MARKER	EACH	362	362	
X		78200006	GUARDRAIL REFLECTORS, TYPE B	EACH	6	6	
		78300200	RAISED REFLECTIVE PAVEMENT MARKER REMOVAL	EACH	384	384	
		78300202	PAVEMENT MARKING REMOVAL - WATER BLASTING	SQ FT	750	750	
X	*	85000200	MAINTENANCE OF EXISTING TRAFFIC SIGNAL INSTALLATION	EACH	1	1	
X	*	88600600	DETECTOR LOOP REPLACEMENT	FOOT	80	80	
X	*	89502376	REBUILD EXISTING HANDHOLE	EACH	1	1	

CONSTRUCTION CODE ITEP FUNDS 80% FEDS / 20% STATE

SPECIALTY	SPECIAL PROVISION	CODED PAY ITEM NO.	ITEM	UNIT	TOTAL QUANTITY	FACILITIES FOR BICYCLE/PEDESTRIAN TRAILS 0028 URBAN	TRAINEES 0042 URBAN
X	*	89502400	REMOVE EXISTING FLASHING BEACON INSTALLATION COMPLETE	EACH	4	4	
	*	X0326806	WASHOUT BASIN	L SUM	1	1	
	*	X0326898	CENTER LINE - RUMBLE STRIP - 16"	FOOT	1603	1603	
X	*	X1400326	RECTANGULAR RAPID FLASHING BEACON ASSEMBLY (COMPLETE)	EACH	3	3	
	*	X2010400	STUMP REMOVAL ONLY	UNIT	219	219	
X	*	X2510635	HEAVY DUTY EROSION CONTROL BLANKET, SPECIAL	SQ YD	202	202	
X	*	X2511630	EROSION CONTROL BLANKET (SPECIAL)	SQ YD	1410	1410	
	*	X7010216	TRAFFIC CONTROL AND PROTECTION, (SPECIAL)	L SUM	1	1	
	*	Z0004552	APPROACH SLAB REMOVAL	SQ YD	88	88	
	*	Z0012136	BRIDGE DECK SCARIFICATION 1 1/2"	SQ YD	304	304	
	*	Z0013797	STABILIZED CONSTRUCTION ENTRANCE	SQ YD	20	20	
	*	Z0013798	CONSTRUCTION LAYOUT	L SUM	1	1	
	*	Z0030850	TEMPORARY INFORMATION SIGNING	SQ FT	52	52	
X	*	Z0073510	TEMPORARY TRAFFIC SIGNAL TIMING	EACH	1	1	
	*	Z0076600	TRAINEES	HOUR	500		500
	*	Z0076604	TRAINEES TRAINING PROGRAM GRADUATE	HOUR	500		500

FILE NAME =	USER NAME = mthomas	DESIGNED -	REVISED -	STATE OF ILLINOIS DEPARTMENT OF TRANSPORTATION	OAKTON STREET SIDEPATH SUMMARY OF QUANTITIES	F.A. RTE.	SECTION	COUNTY	TOTAL SHEETS	SHEET NO.
N:\DESIGN\AINES\190138.002203\Civil\500.Dwg	DN_19138-03_01.SHT	DRAWN -	REVISED -			20-00224-00-BT	COOK	89	11	
Default	PLOT SCALE = 4"	CHECKED -	REVISED -			CONTRACT NO. 61J19		ILLINOIS FED. AID PROJECT		
	PLOT DATE = 11/8/2022	DATE -	REVISED -			SCALE:	SHEET	OF	SHEETS	STA.

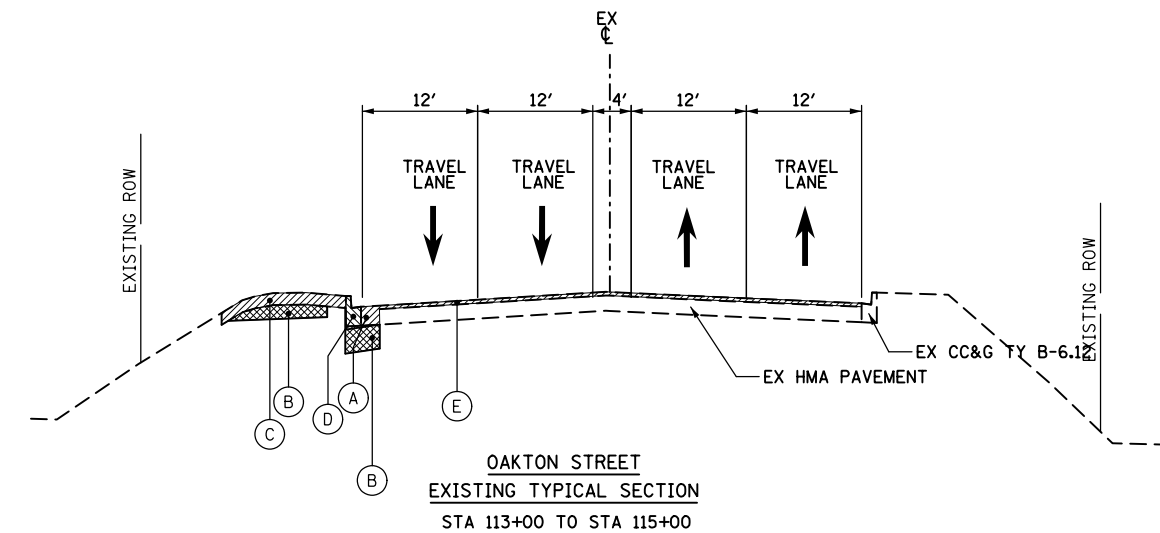
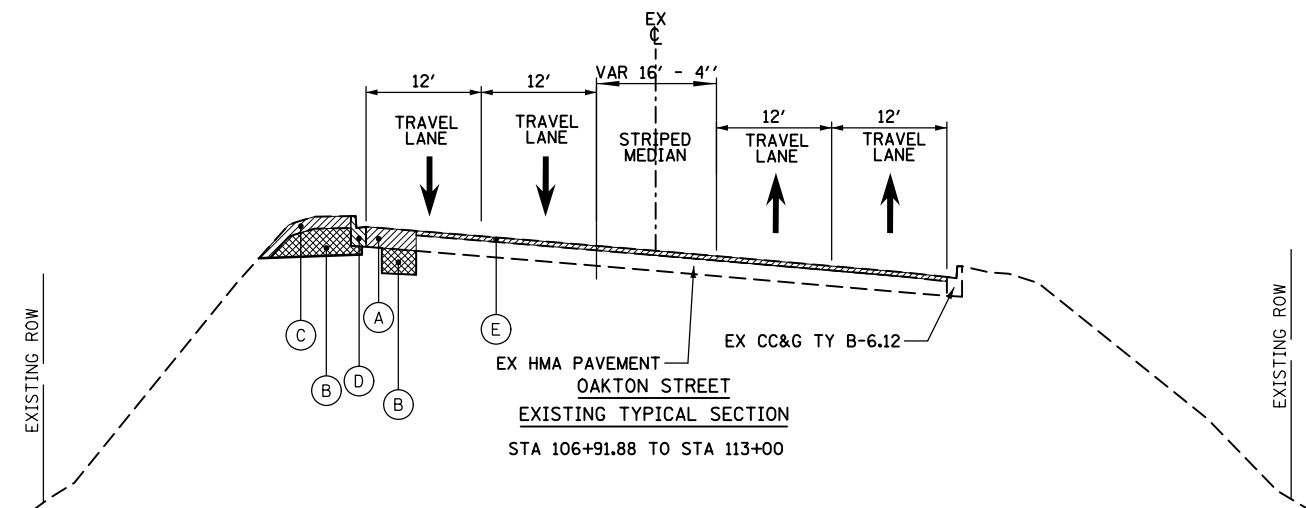
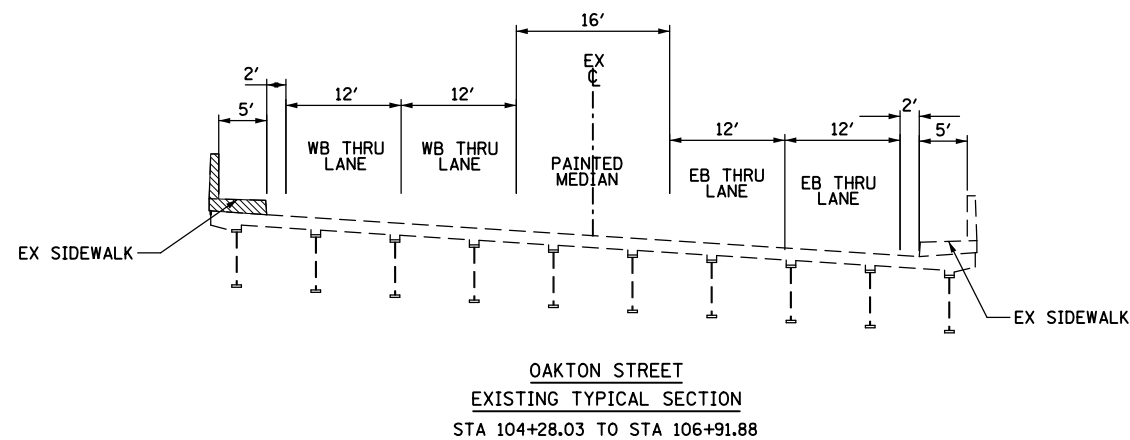
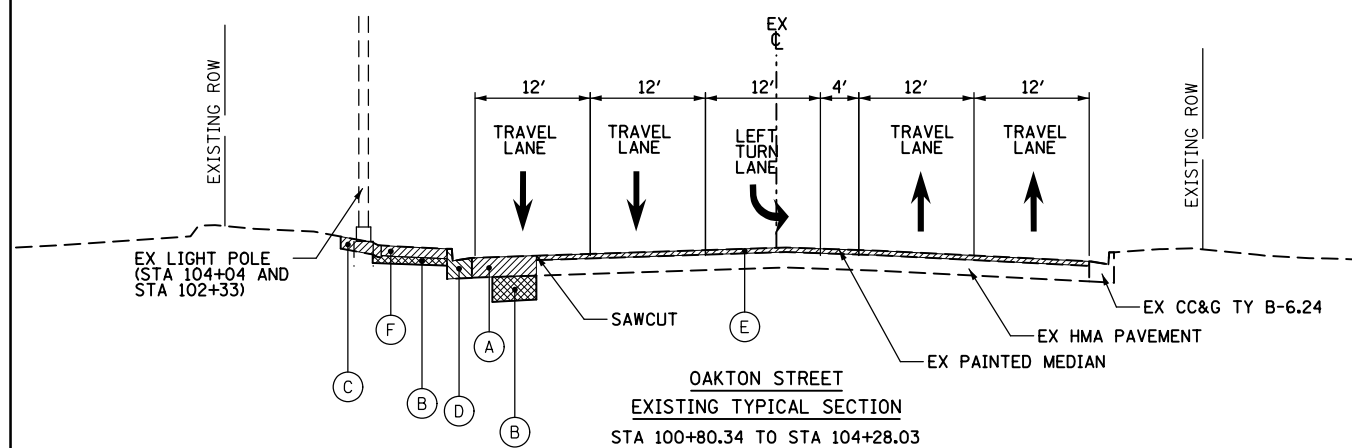
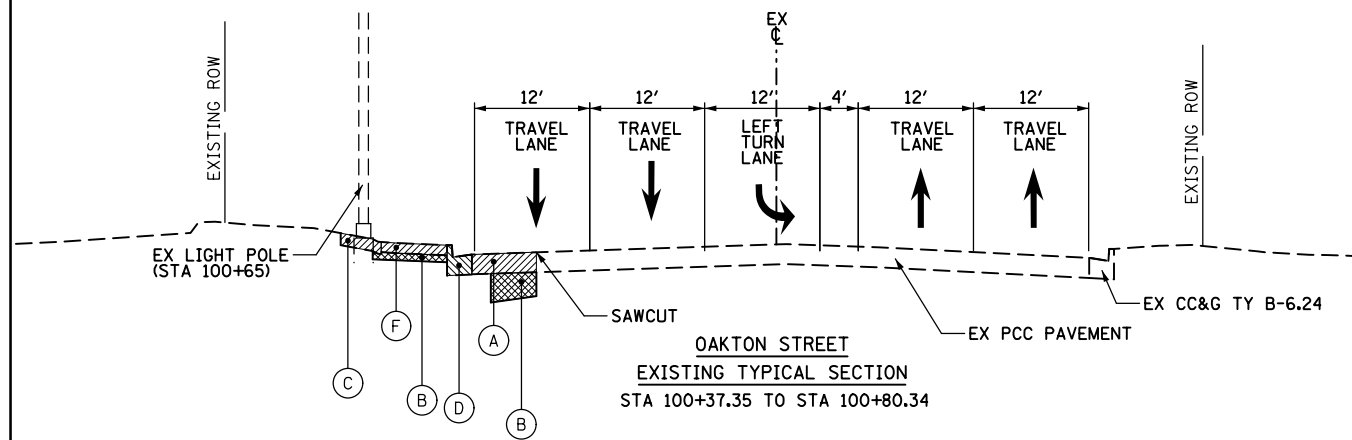

LEGEND

- (A) EXISTING HOT-MIX ASPHALT PAVEMENT TO BE REMOVED (PAID FOR AS PAVEMENT REMOVAL)
- (B) EARTH EXCAVATION
- (C) TOPSOIL EXCAVATION - 6" NOMINAL (PAID FOR AS PART OF REMOVAL AND DISPOSAL OF UNSUITABLE MATERIAL)
- (D) COMBINATION CONCRETE CURB AND GUTTER REMOVAL
- (E) HOT-MIX ASPHALT SURFACE REMOVAL, 2 1/4"
- (F) EXISTING SIDEWALK REMOVAL

REMOVAL ITEMS

NOTE:
 BITUMINOUS FROM RESURFACING LIMIT TO STA 112+00
 PCC PAVEMENT WITH BITUMINOUS OVERLAY VARIABLE DEPTH FROM STA. 112+00 & BEYOND

FILE NAME =	USER NAME = mthomas	DESIGNED -	REVISED -
N:\DESPLAINS\190138.00003\Civil\PR TYP	OAKTON_190138-03_01.sht	DRAWN -	REVISED -
Default	PLOT SCALE = 28'	CHECKED -	REVISED -
	PLOT DATE = 11/8/2022	DATE -	REVISED -

**STATE OF ILLINOIS
 DEPARTMENT OF TRANSPORTATION**

**OAKTON STREET SIDEPATH
 EXISTING TYPICAL SECTIONS**

SCALE: SHEET OF SHEETS STA. TO STA.

F.A. RTE.	SECTION	COUNTY	TOTAL SHEETS	SHEET NO.
	20-00224-00-BT	COOK	89	12
CONTRACT NO. 61J19				
ILLINOIS FED. AID PROJECT				

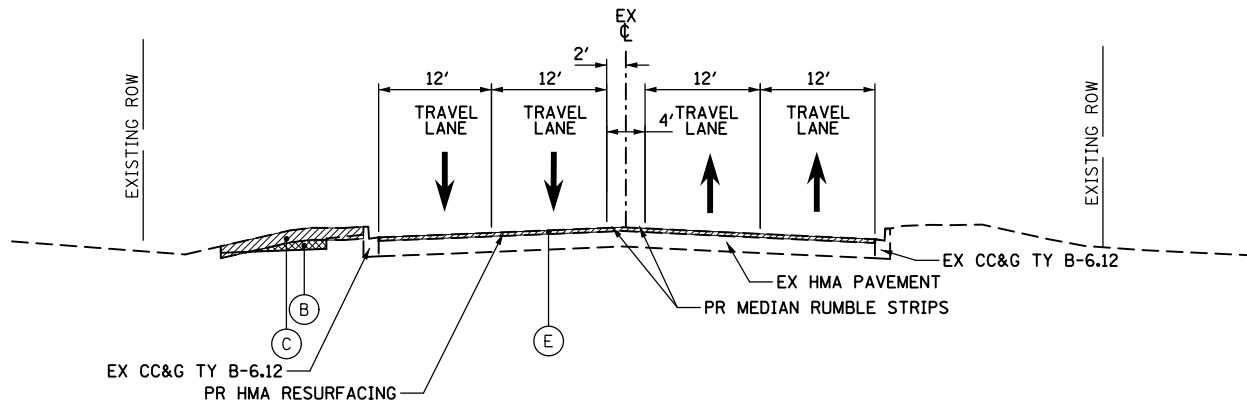

OAKTON STREET
EXISTING TYPICAL SECTION
STA 115+00 TO STA 119+71.35

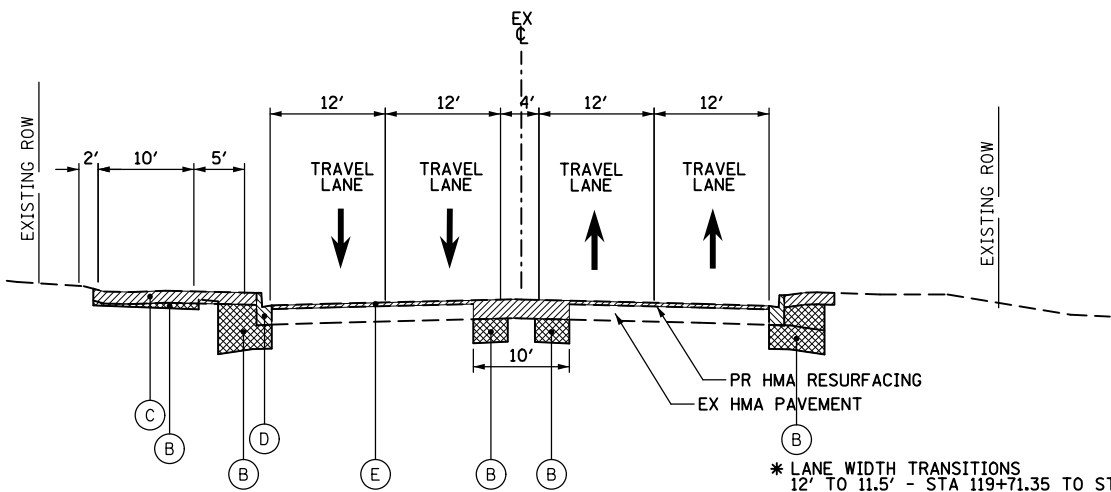

OAKTON STREET
EXISTING TYPICAL SECTION
STA 119+71.35 TO STA 122+63.35

* LANE WIDTH TRANSITIONS
12' TO 11.5' - STA 119+71.35 TO STA 120+91.35
11.5' TO 12' - STA 121+43.35 TO STA 122+63.45

** MEDIAN WIDTH TRANSITIONS
4' TO 10' - STA 119+71.35 TO STA 120+91.35
10' TO 4' - STA 121+43.35 TO STA 122+63.35

LEGEND

- (A) EXISTING HOT-MIX ASPHALT PAVEMENT TO BE REMOVED (PAID FOR AS PAVEMENT REMOVAL)
- (B) EARTH EXCAVATION
- (C) TOPSOIL EXCAVATION - 6" NOMINAL (PAID FOR AS PART OF REMOVAL AND DISPOSAL OF UNSUITABLE MATERIAL)
- (D) COMBINATION CONCRETE CURB AND GUTTER REMOVAL
- (E) HOT-MIX ASPHALT SURFACE REMOVAL, 2 1/4"
- REMOVAL ITEMS

FILE NAME =	USER NAME = mthomas	DESIGNED -	REVISED -
N:\DESPLAINS\190138.000\03\Civil\PR TYP\OAKTON_190138-03_01.sht		DRAWN -	REVISED -
Default	PLOT SCALE = 28'	CHECKED -	REVISED -
	PLOT DATE = 11/8/2022	DATE -	REVISED -

STATE OF ILLINOIS
DEPARTMENT OF TRANSPORTATION

OAKTON STREET SIDEPATH
EXISTING TYPICAL SECTIONS

SCALE: SHEET OF SHEETS STA. TO STA.

F.A. RTE.	SECTION	COUNTY	TOTAL SHEETS	SHEET NO.
	20-00224-00-BT	COOK	89	13
CONTRACT NO. 61J19				
ILLINOIS FED. AID PROJECT				

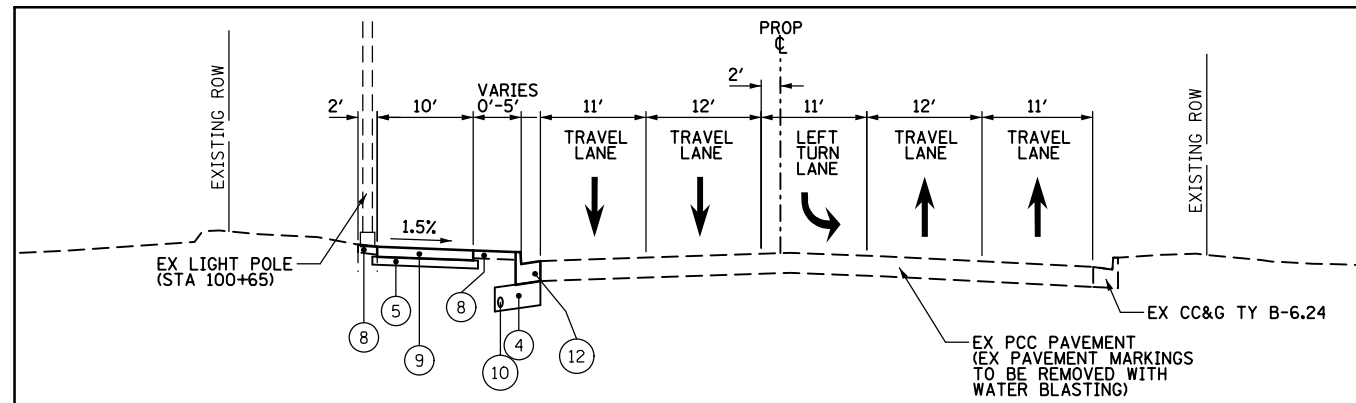

OAKTON STREET
PROPOSED TYPICAL SECTION
STA 100+37.35 TO STA 100+80.34

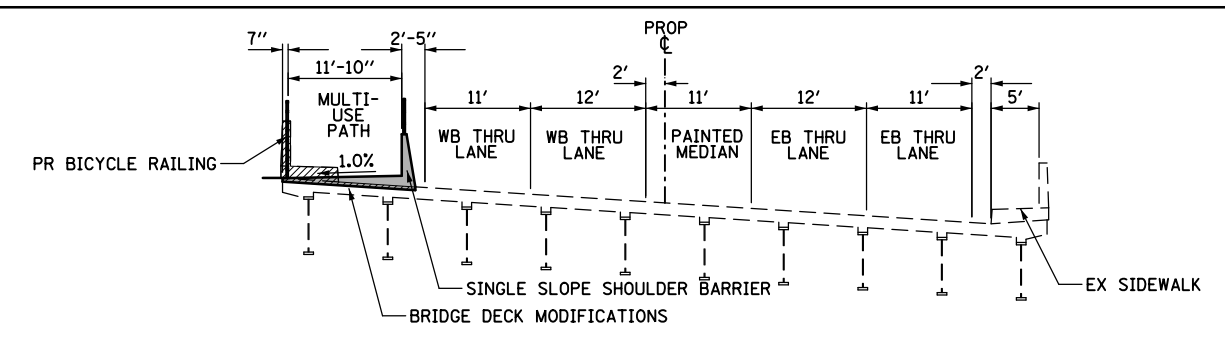

OAKTON STREET
PROPOSED TYPICAL SECTION
STA 104+28.03 TO STA 106+91.88

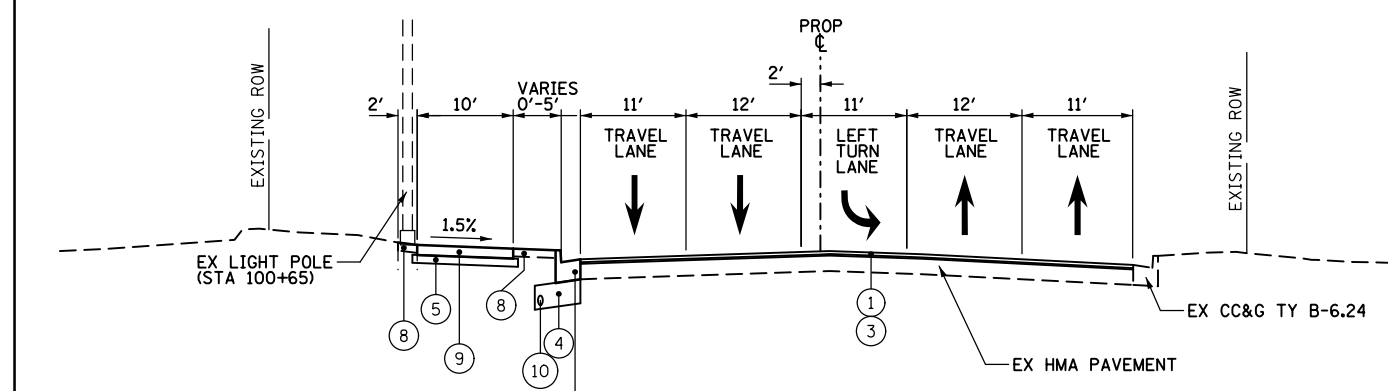

OAKTON STREET
PROPOSED TYPICAL SECTION
STA 100+80.34 TO STA 102+16.03

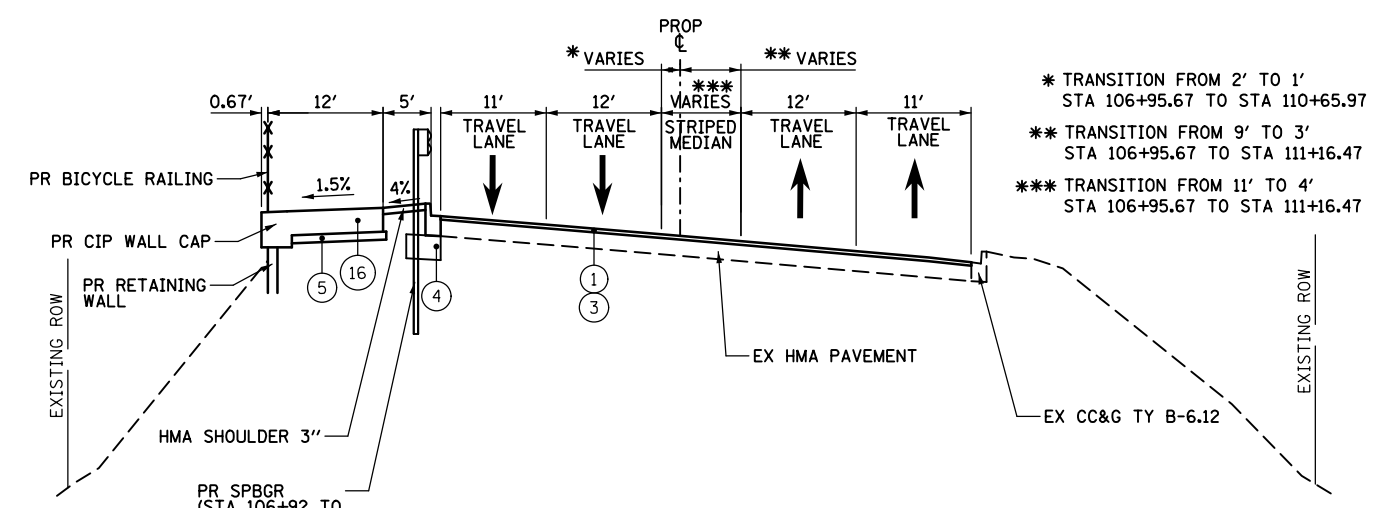

OAKTON STREET
PROPOSED TYPICAL SECTION
STA 106+91.88 TO STA 113+00

* TRANSITION FROM 2' TO 1'
STA 106+95.67 TO STA 110+65.97
** TRANSITION FROM 9' TO 3'
STA 106+95.67 TO STA 111+16.47
*** TRANSITION FROM 11' TO 4'
STA 106+95.67 TO STA 111+16.47

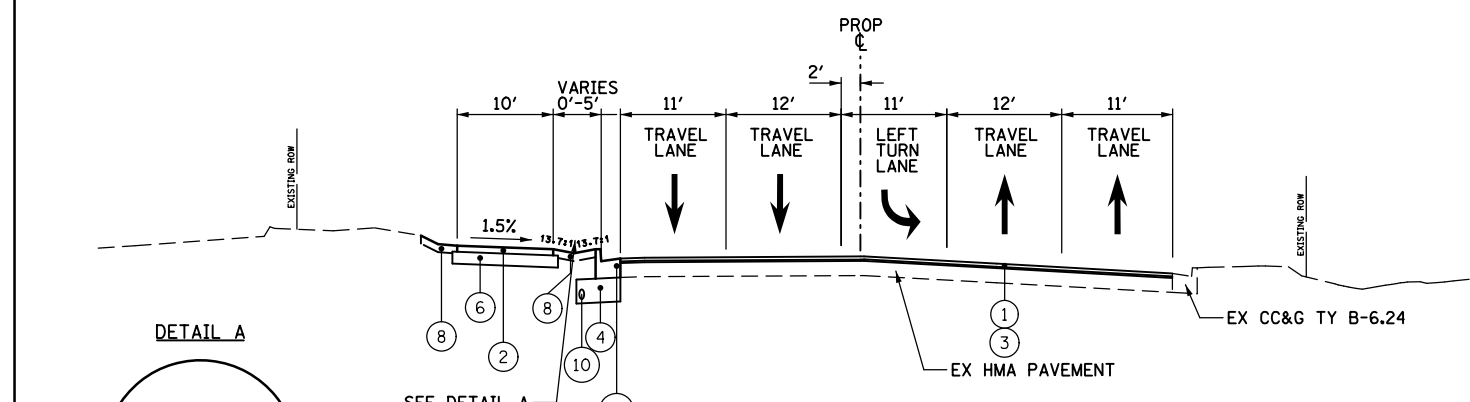

OAKTON STREET
PROPOSED TYPICAL SECTION
STA 102+16.03 TO STA 104+28.03

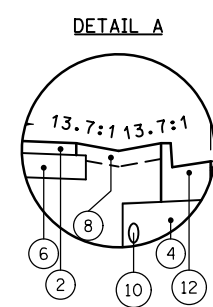

NOTE:
LONGITUDINAL JOINT SEALANT SHALL BE INSTALLED
AT ALL INTERIOR JOINTS.

LEGEND

① 1 1/2" HOT-MIX ASPHALT SURFACE COURSE, IL-9.5 MIX "D", N70	⑪ NOT USED
② 3" HOT-MIX ASPHALT SURFACE COURSE, IL-9.5 MIX "D", N50	⑫ COMBINATION CURB & GUTTER, TYPE B-6.24
③ 3/4" POLYMERIZED HOT-MIX ASPHALT BINDER COURSE, IL-4.75, N50	⑬ COMBINATION CURB & GUTTER, TYPE B-6.12
④ AGGREGATE SUBGRADE IMPROVEMENT, 12"	⑭ NOT USED
⑤ AGGREGATE BASE COURSE, TYPE B, 4"	⑮ BICYCLE RAILING
⑥ AGGREGATE BASE COURSE, TYPE B, 6"	⑯ CONCRETE STRUCTURES (SEE STRUCTURAL PLANS)
⑦ NOT USED	⑰ MEDIAN RUMBLE STRIPS
⑧ TOPSOIL FURNISH AND PLACE 4"; SEEDING CL 2A	⑱ 9 1/4" HOT-MIX ASPHALT BINDER COURSE IL-19.0, MIX "D", N70
⑨ 5" PCC SIDEWALK	
⑩ PIPE UNDERDRAINS, 4"	

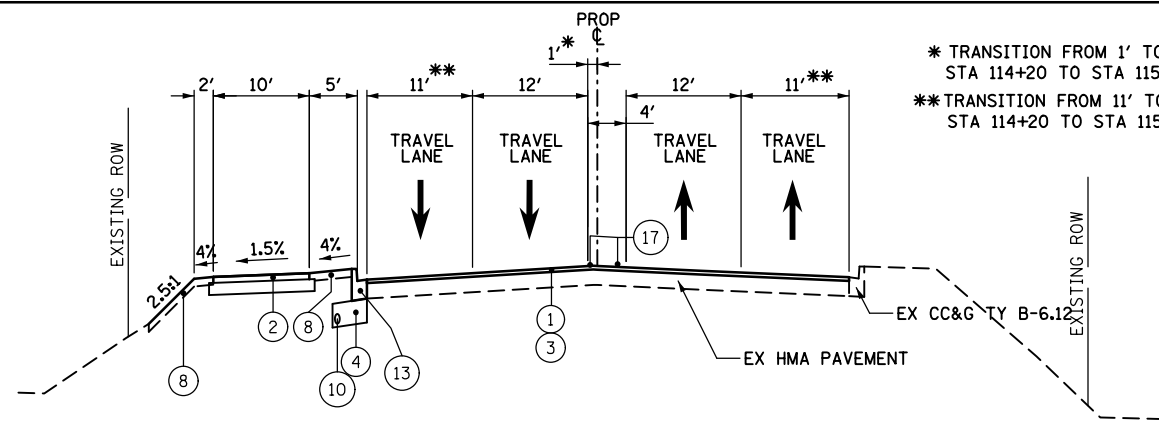

OAKTON STREET
PROPOSED TYPICAL SECTION
STA 113+00 TO STA 115+00

* TRANSITION FROM 1' TO 2'
STA 114+20 TO STA 115+00
** TRANSITION FROM 11' TO 12'
STA 114+20 TO STA 115+00

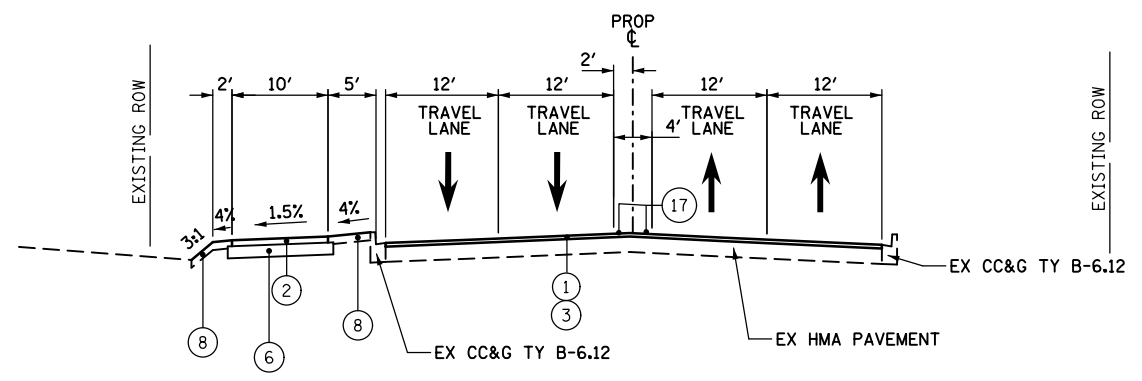

OAKTON STREET
PROPOSED TYPICAL SECTION
STA 117+00 TO STA 119+71.35

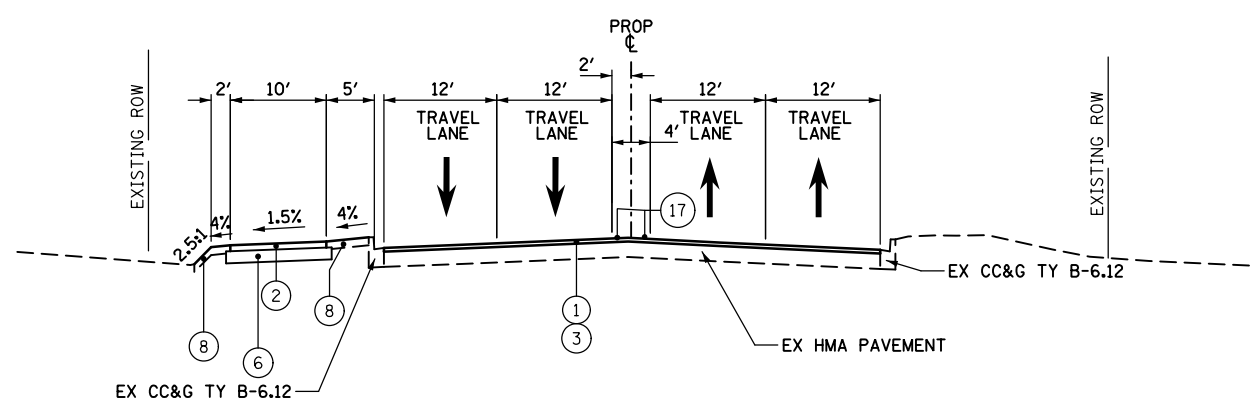

OAKTON STREET
PROPOSED TYPICAL SECTION
STA 115+00 TO STA 117+00

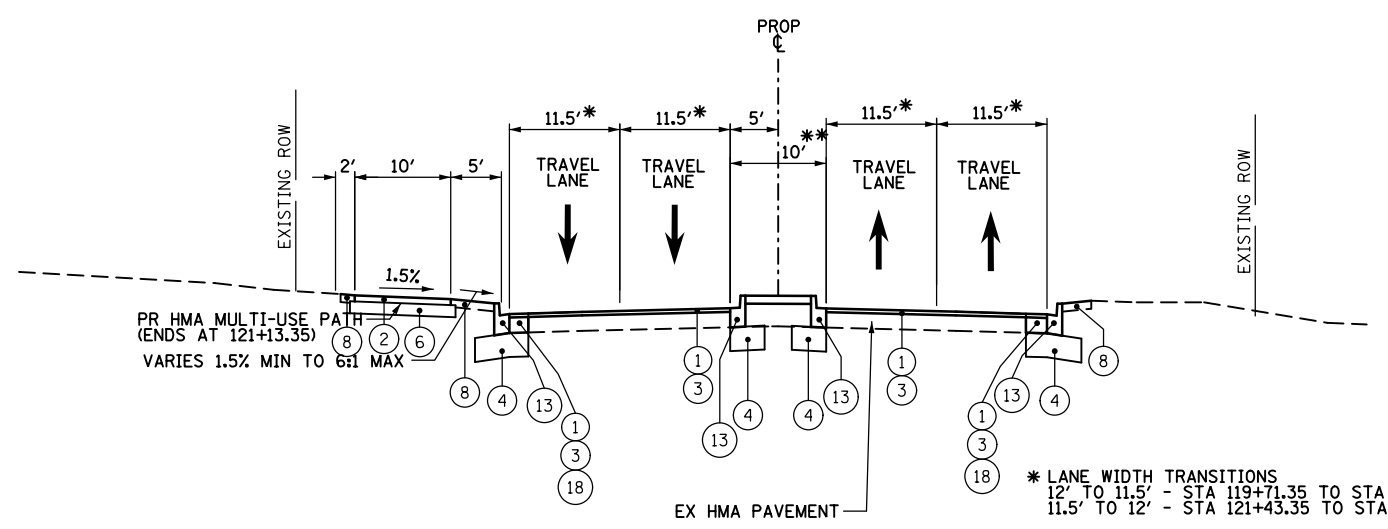

OAKTON STREET
PROPOSED TYPICAL SECTION
STA 119+71.35 TO STA 122+63.35

* LANE WIDTH TRANSITIONS
12' TO 11.5' - STA 119+71.35 TO STA 120+91.35
11.5' TO 12' - STA 121+43.35 TO STA 122+63.45
** MEDIAN WIDTH TRANSITIONS
4' TO 10' - STA 119+71.35 TO STA 120+91.35
10' TO 4' - STA 121+43.35 TO STA 122+63.35

HOT-MIX ASPHALT MIXTURE REQUIREMENTS		
MIXTURE TYPE	AIR VOIDS @NDES	QMP
SHARED USE PATH		
HOT-MIX ASPHALT SURFACE COURSE, IL-9.5, MIX "D", N50, 3" (IN 2 LIFTS)	4% @ 50 GYR.	LR-1030-2
RESURFACING		
HOT-MIX ASPHALT SURFACE COURSE, IL-9.5, MIX "D", N70, 1.5"	4% @ 70 GYR.	LR-1030-2
POLYMERIZED HOT-MIX ASPHALT BINDER COURSE, IL-4.75, N50, 3/4"	3.5% @ 50 GYR.	LR-1030-2
HMA WIDENING		
HOT-MIX ASPHALT SURFACE COURSE, IL-9.5, MIX "D", N70, 1.5"	4% @ 70 GYR.	LR-1030-2
POLYMERIZED HOT-MIX ASPHALT BINDER COURSE, IL-4.75, N50, 3/4"	3.5% @ 50 GYR.	LR-1030-2
HOT-MIX ASPHALT BINDER COURSE IL-19.0, N70, 9 1/4"	4% @ 70 GYR.	LR-1030-2
HMA SHOULDER 3"		
HOT-MIX ASPHALT BINDER COURSE, IL-19.0, N50, 3"	4% @ 50 GYR.	LR-1030-2
QMP DESIGNATION: QUALITY CONTROL/QUALITY ASSURANCE (QC/QA) PER LR 1030-2		

THE UNIT WEIGHT USED TO CALCULATE ALL HOT-MIX ASPHALT SURFACE MIXTURES IS 112 LBS/SQYD/IN.
THE "AC TYPE" FOR POLYMERIZED HMA MIXES SHALL BE "SBS/SBR PG 76-22" AND FOR NON-POLYMERIZED HMA THE "AC TYPE" SHALL BE "PG 64-22" UNLESS MODIFIED BY RECLAIMED MATERIALS SPECIFICATIONS.

NOTE:
LONGITUDINAL JOINT SEALANT SHALL PLACED OVER THE
POLYMERIZED HMA CB IL-4.75 N50.

LEGEND	
① 1 1/2" HOT-MIX ASPHALT SURFACE COURSE, IL-9.5 MIX "D", N70	⑪ NOT USED
② 3" HOT-MIX ASPHALT SURFACE COURSE, IL-9.5 MIX "D", N50	⑫ COMBINATION CURB & GUTTER, TYPE B-6.24
③ 3*4" POLYMERIZED HOT-MIX ASPHALT BINDER COURSE, IL-4.75, N50	⑬ COMBINATION CURB & GUTTER, TYPE B-6.12
④ AGGREGATE SUBGRADE IMPROVEMENT, 12"	⑭ NOT USED
⑤ AGGREGATE BASE COURSE, TYPE B, 4"	⑮ BICYCLE RAILING
⑥ AGGREGATE BASE COURSE, TYPE B, 6"	⑯ CONCRETE STRUCTURES (SEE STRUCTURAL PLANS)
⑦ NOT USED	⑰ MEDIAN RUMBLE STRIPS
⑧ TOPSOIL FURNISH AND PLACE 4"; SEEDING CL 2A	⑱ 9 1/4" HOT-MIX ASPHALT BINDER COURSE IL-19.0, MIX "D", N70
⑨ 5" PCC SIDEWALK	
⑩ PIPE UNDERDRAINS, 4"	

STATION	TOP SOIL STRIPPING	CUT (EXCLUSIVE OF T/S STRIPPING, PAV'T REMOVAL, C&G REMOVAL, DRIVEWAY REMOVAL)	FILL	TOP SOIL STRIPPING	CUT VOLUME	USED IN EMBANKMENT ADJUSTED FOR SHRINKAGE (15% SHRINKAGE FACTOR)	FILL	EARTHWORK BALANCE ("+" = WASTE, "-" = SHORTAGE)
	(SQ FT)	(SQ FT)	(SQ FT)	(CU YD)	(CU YD)	(CU YD)	(CU YD)	(CU YD)
100+50.00	0.6	7.6	1.9					
101+00.00	4.7	4.7	9.3	4.9	11.4	9.7	10.4	-0.7
101+50.00	4.3	12.0	0.1	8.3	15.5	13.1	8.7	4.4
101+61.26	4.7	6.5	12.1	1.9	3.9	3.3	2.5	0.7
102+00.00	4.0	9.0	0.0	6.2	11.1	9.5	8.7	0.8
102+50.00	1.6	6.4	5.1	5.2	14.3	12.1	4.7	7.4
103+00.00	2.1	7.0	5.2	3.4	12.4	10.5	9.5	1.0
103+50.00	1.6	6.3	5.4	3.4	12.3	10.5	9.8	0.7
104+00.00	1.6	7.0	4.7	3.0	12.3	10.5	9.4	1.1
104+50.00	0.9	3.4	3.6	2.3	9.6	8.2	7.7	0.5
105+00.00	0.0	0.0	0.0	0.8	3.1	2.7	3.3	-0.7
105+50.00	0.0	0.0	0.0	0.0	0.0	0.0	0.0	0.0
106+00.00	0.0	0.0	0.0	0.0	0.0	0.0	0.0	0.0
106+50.00	0.0	0.0	0.0	0.0	0.0	0.0	0.0	0.0
107+00.00	3.2	14.2	1.3	3.0	13.1	11.2	1.2	10.0
107+50.00	4.9	15.7	3.8	7.5	27.7	23.5	4.7	18.8
108+00.00	4.6	9.8	3.9	8.8	23.6	20.1	7.1	12.9
108+50.00	4.9	12.5	3.8	8.8	20.6	17.6	7.1	10.4
109+00.00	5.3	13.1	4.0	9.4	23.7	20.1	7.2	12.9
109+50.00	5.7	12.4	4.9	10.2	23.6	20.1	8.2	11.8
110+00.00	6.2	10.1	4.6	11.0	20.8	17.7	8.8	8.9
110+50.00	6.7	9.8	3.9	11.9	18.4	15.7	7.9	7.8
111+00.00	6.8	11.5	2.5	12.5	19.7	16.8	5.9	10.8
111+50.00	6.6	15.5	2.2	12.4	25.0	21.3	4.4	16.9
112+00.00	6.6	14.3	2.3	12.2	27.6	23.5	4.2	19.3
112+50.00	6.6	16.3	4.3	12.2	28.3	24.1	6.1	18.0
113+00.00	10.0	15.4	6.3	15.4	29.4	24.9	9.8	15.1
113+50.00	9.0	6.8	5.0	17.6	20.6	17.5	10.5	7.0
113+77.00	8.7	5.5	4.7	8.9	6.2	5.2	4.9	0.4
114+00.00	8.6	6.5	4.5	7.4	5.1	4.3	3.9	0.4
114+50.00	9.3	7.5	5.4	16.6	13.0	11.0	9.2	1.9
115+00.00	9.5	6.3	5.2	17.4	12.8	10.9	9.8	1.0
115+50.00	9.0	1.5	1.4	17.1	7.2	6.1	6.1	0.0
116+00.00	10.5	1.0	6.1	18.1	2.3	2.0	6.9	-5.0
116+50.00	10.7	1.0	9.5	19.6	1.9	1.6	14.4	-12.9
117+00.00	10.3	2.1	7.7	19.4	2.9	2.4	15.9	-13.5
117+50.00	9.7	2.8	5.3	18.5	4.5	3.9	12.0	-8.2
118+00.00	8.8	2.6	1.9	17.1	5.0	4.3	6.7	-2.4
118+50.00	8.4	3.7	0.8	15.9	5.8	5.0	2.5	2.5
119+00.00	8.2	5.2	0.7	15.4	8.2	7.0	1.4	5.6
119+50.00	8.2	6.8	0.3	15.2	11.1	9.4	0.9	8.5
120+00.00	11.4	14.1	6.5	18.1	19.4	16.4	6.3	10.2
120+50.00	12.5	23.9	5.9	22.1	35.2	29.9	11.5	18.4
121+00.00	11.4	27.6	5.1	22.1	47.7	40.5	10.2	30.3
121+50.00	3.7	24.6	4.6	14.0	48.3	41.1	9.0	32.1

EARTHWORK SUMMARY					
LOCATION	(1) TOPSOIL STRIPPING (CU YD)	(2) CUT VOLUME (EARTH EXCAVATION) (CU YD)	(3) EXCAVATION AVAILABLE FOR EMBANKMENTS ADJUSTED BY 15% SHRINKAGE FACTOR (CU YD)	(4) EMBANKMENT (FILL) (CU YD)	(5) EARTHWORK BALANCE ("+" = WASTE, "-" = SHORTAGE) (CU YD)
DES PLAINES RIVER TRAIL ALONG EAST RIVER ROAD SOUTH OF BRIDGE	475	665	565	300	265
PROJECT TOTALS	475	665	565	300	265

EARTH EXCAVATION (20200100)	665
REMOVAL AND DISPOSAL OF UNSUITABLE MATERIAL (20201200)	475

EARTH EXCAVATION = COLUMN 2
NO QUANTITY IS INCLUDED FOR FURNISHED EXCAVATION BECAUSE EARTHWORK BALANCE IN ALL THREE SECTIONS INDICATE AN EXCESS OF MATERIAL
REMOVAL AND DISPOSAL OF UNSUITABLE MATERIAL = COLUMN 1

STORM SEWER SCHEDULE										
PIPE #	FROM STRUCTURE	TO STRUCTURE	LENGTH (FT)	DIA (IN)	MATERIAL	PIPE TYPE	SLOPE (%)	UPSTREAM INVERT	DOWNSTREAM INVERT	TBF (CY)
P100	S102	S101	2	12	RCP	2	1.11%	629.35	629.33	0.4
P300	S300	S301	43	12	RCP	1	3.64%	633.58	632.00	3.5
P301	S302	S303	28	12	RCP	1	2.87%	633.33	632.54	1.2
P441	S441	S442	42	12	RCP	2	1.05%	631.21	630.77	29.0
P442	S443	S444	35	12	RCP	2	2.34%	631.77	630.95	13.0
P443	S445	S444	7	12	RCP	2	6.57%	631.49	631.03	3.0
P444	S447	S448	32	12	RCP	2	0.34%	629.5	629.39	30.0
P445	S448	S449	19	12	RCP	2	0.42%	629.19	629.11	18.0
P446	S449		8	12	RCP	2	0.50%	628.43	628.39	9.0
P447	S450	S451	30	12	RCP	2	6.73%	631.29	629.27	22.0
P448	S451	S452	9	12	RCP	2	0.78%	628.35	628.28	9.0
P449	S452		8	12	RCP	2	0.50%	627.04	627	10.0

DRAINAGE STRUCTURE SCHEDULE									
STRUCTURE	STRUCTURE TYPE	FRAME TYPE	STATION	OFFSET	RIM	INV N	INV S	INV E	INV W
S100	CB, TYPE C	TY 24 F&G	101+61.26	25.0' LT	632.45	-	627.83	-	-
S101	CB, TYPE C	TY 24 F&G	102+50.16	25.0' LT	634.11	629.33	629.23	-	-
S102	CB, TYPE C	TY 8 F&G	102+49.86	29.79 LT	634.33	-	629.35	-	-
S300	CB TYPE C	TY 23 F&G	112+54.00	24.0 LT	636.29 (EX)	-	-	633.58	-
S301	CB TYPE A, 4' DIAMETER	TY 23 F&G	113+01.44	24.0 LT	636.2	-	631.90	-	632.00
S302	CB TYPE C	TY 23 F&G	113+77.00	24.0 LT	636.06	-	-	633.33	-
S303	CB TYPE A, 4' DIAMETER	TY 23 F&G	114+04.50	24.0 LT	636.02	-	632.44	-	632.54
S441	CB TYPE A, 4' DIAMETER	TY 23 F&G	119+95.68	26.26 LT	634.93			631.21	631.21
S442	CB TYPE A, 5' DIAMETER	TY 23 F&G	120+37.36	27.06 LT	634.78		630.73		630.77
S443	CB TYPE A, 4' DIAMETER	TY 23 F&G	121+27.67	28.00 LT	634.7			631.77	
S444	CB TYPE A, 5' DIAMETER	TY 23 F&G	121+62.24	27.69 LT	634.65		630.03	631.03	630.95
S445	CB TYPE A, 4' DIAMETER	TY 23 F&G	121+68.74	27.58 LT	634.56				631.49
S446	CB TYPE A, 4' DIAMETER	TY 23 F&G	122+38.07	26.41 LT	634.67			631.95	
S447	CB TYPE A, 4' DIAMETER	TY 23 F&G	119+85.42	26.58 RT	634.96			629.5	629.62
S448	CB TYPE A, 4' DIAMETER	TY 23 F&G	120+16.44	27.00 RT	634.85			629.19	629.39
S449	CB TYPE A, 5' DIAMETER	TY 23 F&G	120+35.24	27.25 RT	634.81	629.87	628.43		629.11
S450	CB TYPE A, 4' DIAMETER	TY 23 F&G	121+24.08	28.00 RT	634.63			631.29	
S451	CB TYPE A, 4' DIAMETER	TY 23 F&G	121+54.24	27.82 RT	634.54			628.35	629.27
S452	CB TYPE A, 5' DIAMETER	TY 23 F&G	121+63.17	27.67 RT	634.52	628.4	627.04		628.28
S453	CB TYPE A, 4' DIAMETER	TY 23 F&G	122+43.57	26.27 RT	634.67			631.44	

ELEVATION BENCHMARKS DATUM: NAVD '88 DESPLAINES DATUM		
NO.	DESCRIPTION	ELEV.
BM 59	DESPLAINES MONUMENT SET IN CONCRETE AT SW CORNER OF OAKTON ST. & LEE/MANNHEIM 21' SOUTH OF E/P OF OAKTON ST. & 25' WEST OF E/P OF LEE/MANNHEIM (GPS OBSERVED)	645.78
OSBM 20-1	SQUARE CUT ON SOUTHWEST CORNER OF CONC. WALL ON SOUTH SIDE OF OAKTON ST. BRIDGE OVER THE DES PLAINES RIVER	639.57

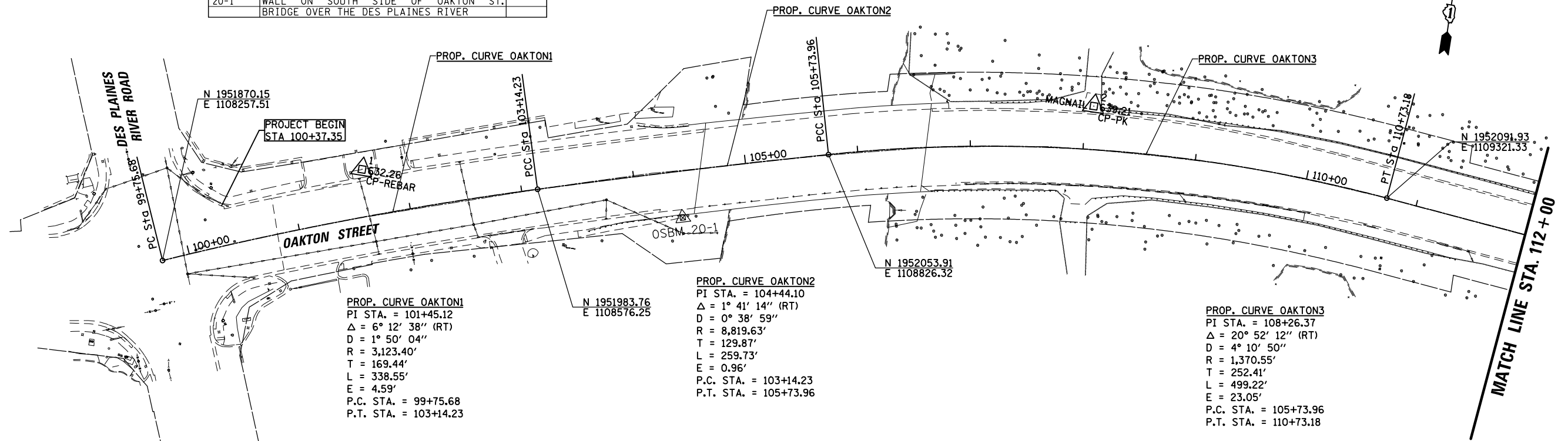
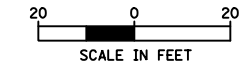

PROP. CURVE OAKTON1
 PI STA. = 101+45.12
 $\Delta = 6^\circ 12' 38''$ (RT)
 $D = 1^\circ 50' 04''$
 $R = 3,123.40'$
 $T = 169.44'$
 $L = 338.55'$
 $E = 4.59'$
 P.C. STA. = 99+75.68
 P.T. STA. = 103+14.23

N 1951983.76
E 1108576.25

PROP. CURVE OAKTON2
 PI STA. = 104+44.10
 $\Delta = 1^\circ 41' 14''$ (RT)
 $D = 0^\circ 38' 59''$
 $R = 8,819.63'$
 $T = 129.87'$
 $L = 259.73'$
 $E = 0.96'$
 P.C. STA. = 103+14.23
 P.T. STA. = 105+73.96

N 1952053.91
E 1108826.32

PROP. CURVE OAKTON3
 PI STA. = 108+26.37
 $\Delta = 20^\circ 52' 12''$ (RT)
 $D = 4^\circ 10' 50''$
 $R = 1,370.55'$
 $T = 252.41'$
 $L = 499.22'$
 $E = 23.05'$
 P.C. STA. = 105+73.96
 P.T. STA. = 110+73.18

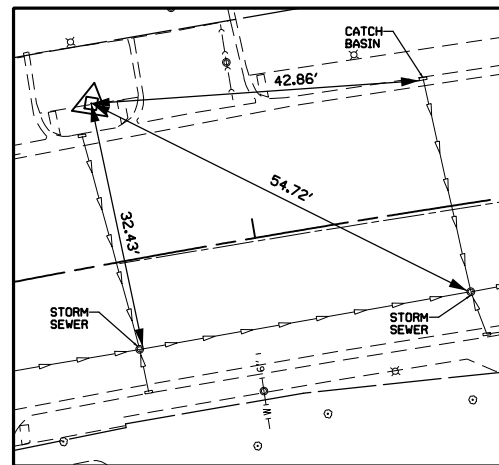

CP 1 - REBAR
 STA. 101+64.35, 41.96'LT
 N 1108419.79
 E 1951977.34

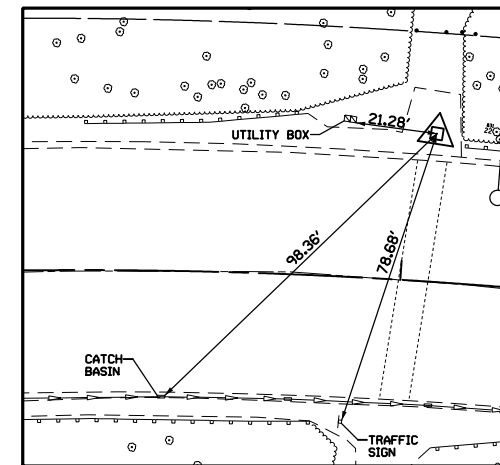

CP 2 - PK
 STA. 108+07.00, 38.60'LT
 N 1109052.16
 E 1952132.60

FILE NAME =	USER NAME = mthomas	DESIGNED -	REVISED -
N:\DESPLAINES\190138.000\03\Civil\TAB.OAK	ON_190138-03_01.sht	DRAWN -	REVISED -
Default	PLOT DATE = 11/8/2022	CHECKED -	REVISED -
		DATE -	REVISED -

**STATE OF ILLINOIS
DEPARTMENT OF TRANSPORTATION**

OAKTON STREET SIDEPATH ALIGNMENT TIES AND BENCHMARKS			
SCALE:	SHEET	OF SHEETS	STA. TO STA.

F.A. RTE.	SECTION	COUNTY	TOTAL SHEETS	SHEET NO.
	20-00224-00-BT	COOK	89	18
CONTRACT NO. 61J19				
ILLINOIS FED. AID PROJECT				

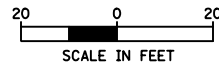

MATCH LINE STA. 112 + 00

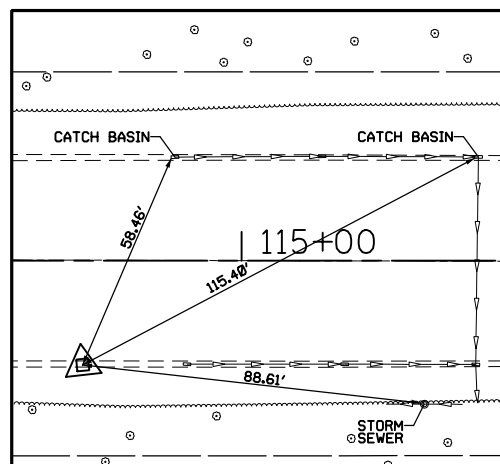
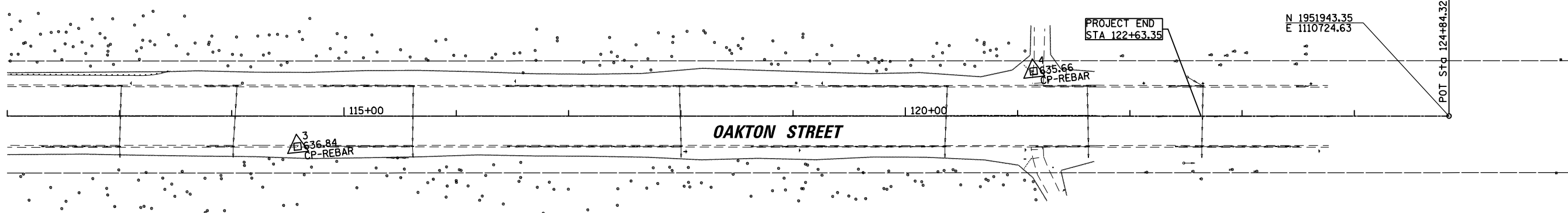

CP 3 - REBAR
STA. 114+58.64, 27.12' RT
N 1109701.79
E 1952024.37

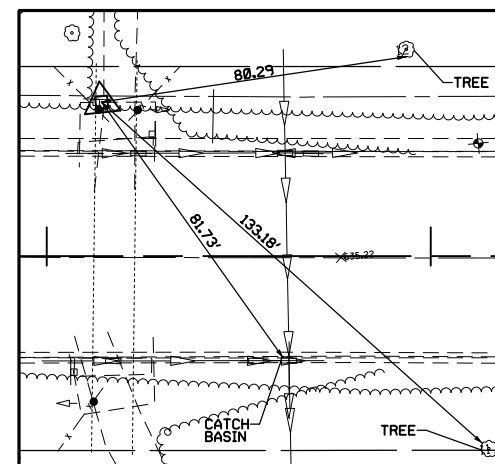

CP 205213 - SET HUB
STA. 12114.30, 40.06' LT
N 1110360.87
E 1952022.15

FILE NAME =	USER NAME = mthomas	DESIGNED -	REVISED -
N:\DESPLAINS\190138\00003\Civil\TAB.DWG	ON_190138-03_02.sht	DRAWN -	REVISED -
Default	PLOT SCALE = 100'	CHECKED -	REVISED -
	PLOT DATE = 11/8/2022	DATE -	REVISED -

STATE OF ILLINOIS
DEPARTMENT OF TRANSPORTATION

OAKTON STREET SIDEPATH
ALIGNMENT TIES AND BENCHMARKS

SCALE: SHEET OF SHEETS STA. TO STA.

F.A. RTE.	SECTION	COUNTY	TOTAL SHEETS	SHEET NO.
	20-00224-00-BT	COOK	89	19
CONTRACT NO. 61J19				
ILLINOIS FED. AID PROJECT				

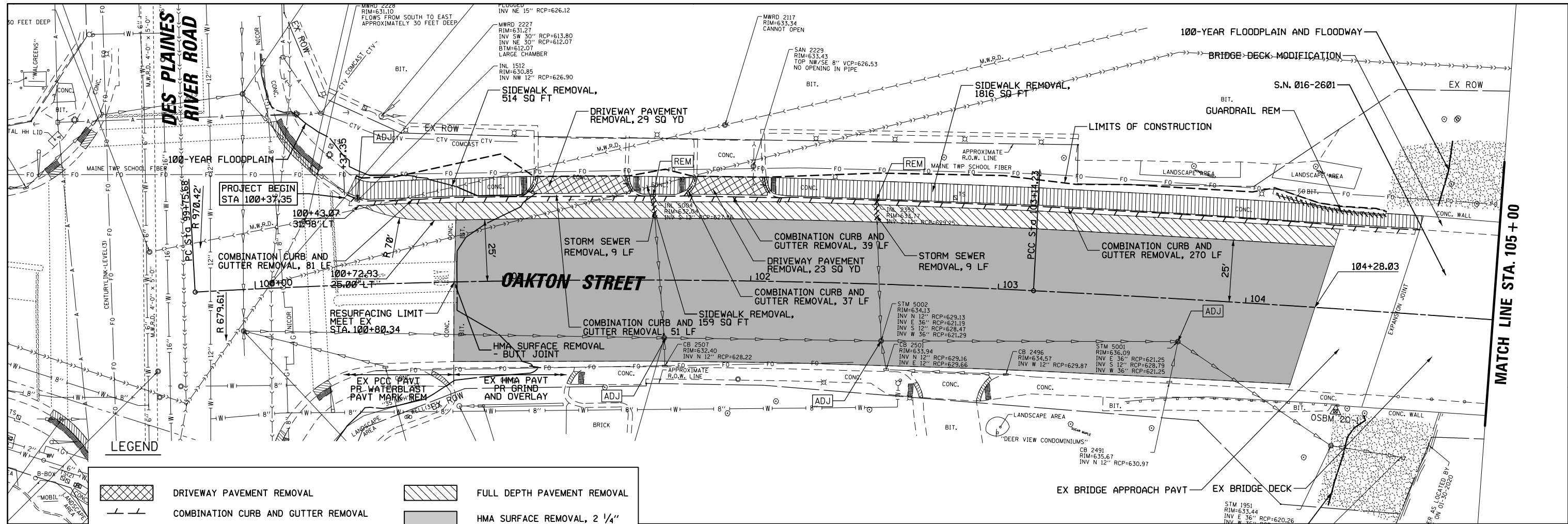

	DRIVEWAY PAVEMENT REMOVAL		FULL DEPTH PAVEMENT REMOVAL
	COMBINATION CURB AND GUTTER REMOVAL		HMA SURFACE REMOVAL, 2 1/4"
	TREE REMOVAL		SIDEWALK REMOVAL
	LINEAR ITEM REMOVAL		
	TREE TRUNK PROTECTION, TREE ROOT PRUNING, & TREE PRUNING		

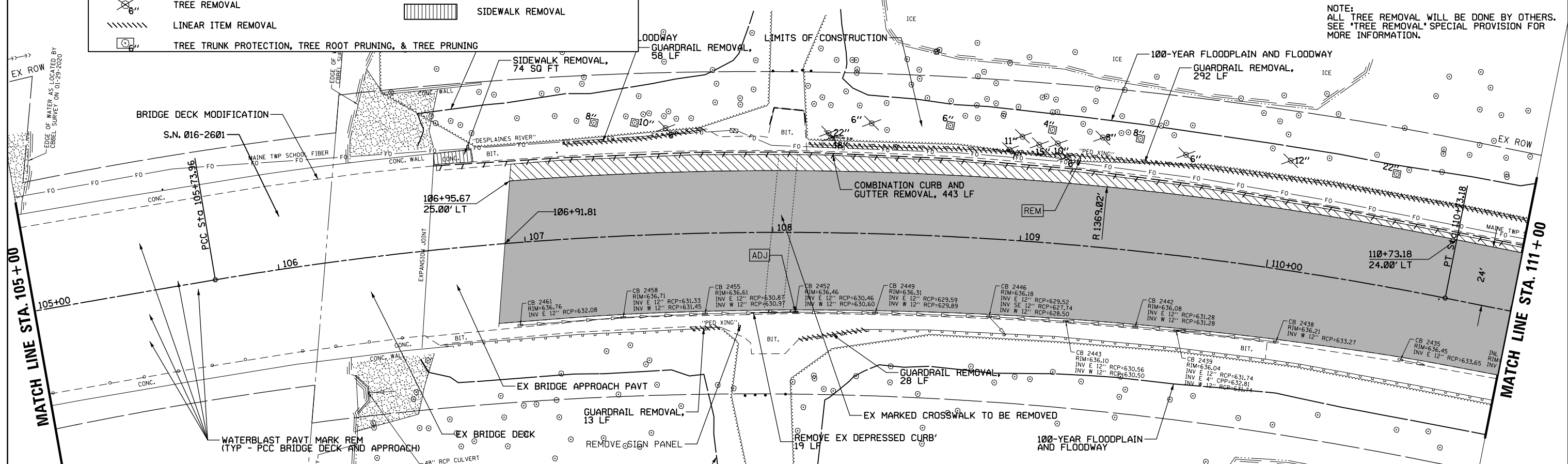

FILE NAME = N:\DESPLAINES\190138-00003\Civil\REM.DWG	USER NAME = mthomas	DESIGNED -	REVISED -	STATE OF ILLINOIS DEPARTMENT OF TRANSPORTATION	OAKTON STREET SIDEPATH EXISTING CONDITIONS AND REMOVAL PLAN	F.A. RTE.	SECTION	COUNTY	TOTAL SHEETS	SHEET NO.	
Default	PLOT DATE = 11/8/2022	DRAWN -	REVISED -			SCALE:	SHEET OF SHEETS	20-00224-00-BT	COOK	89	20
		CHECKED -	REVISED -			DATE	STA. TO STA.	CONTRACT NO. 61J19			
		DATE	REVISED -			ILLINOIS FED. AID PROJECT					

NOTE:
ALL TREE REMOVAL WILL BE DONE BY OTHERS.
SEE 'TREE REMOVAL' SPECIAL PROVISION FOR
MORE INFORMATION.

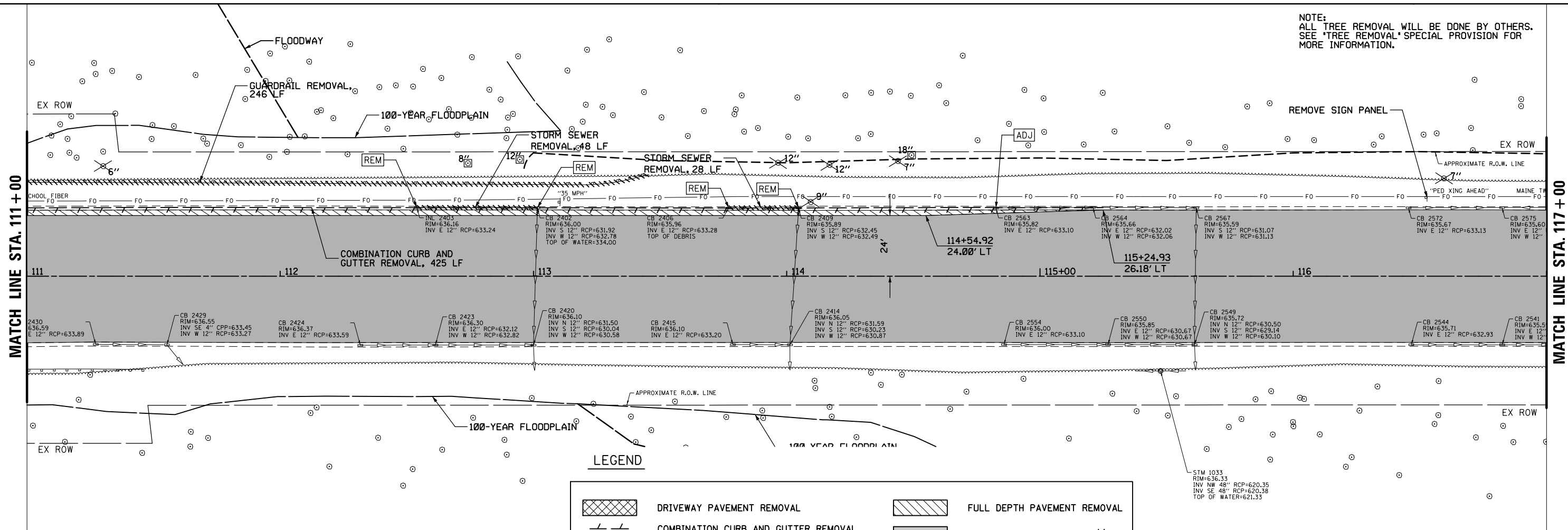

LEGEND

	DRIVEWAY PAVEMENT REMOVAL		FULL DEPTH PAVEMENT REMOVAL
	COMBINATION CURB AND GUTTER REMOVAL		HMA SURFACE REMOVAL, 2 1/4"
	TREE REMOVAL		SIDEWALK REMOVAL
	LINEAR ITEM REMOVAL		
	TREE TRUNK PROTECTION, TREE ROOT PRUNING, & TREE PRUNING		

NOTE:
ALL TREE REMOVAL WILL BE DONE BY OTHERS.
SEE 'TREE REMOVAL' SPECIAL PROVISION FOR
MORE INFORMATION.

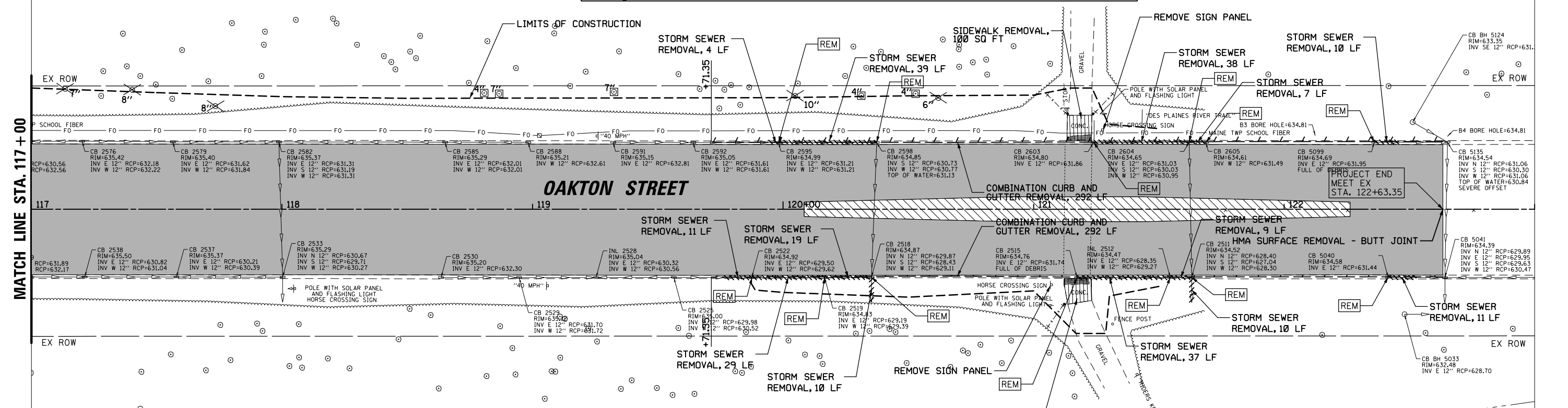

FILE NAME = N:\DESPLAINES\190138-00003\Civil\REM_OAK	USER NAME = mthomas	DESIGNED -	REVISED -	STATE OF ILLINOIS DEPARTMENT OF TRANSPORTATION	OAKTON STREET SIDEPATH EXISTING CONDITIONS AND REMOVAL PLAN	F.A. RTE.	SECTION	COUNTY	TOTAL SHEETS	SHEET NO.	
Default	DN_190138-03_02.sht	DRAWN -	REVISED -			20-00224-00-BT	COOK	89	21		
	PLOT SCALE = 48"	CHECKED -	REVISED -			CONTRACT NO. 61J19					
	PLOT DATE = 11/8/2022	DATE -	REVISED -			ILLINOIS FED. AID PROJECT					

PLAN	SURVEYED	DATE
	PLOTTED	
	GRADES CHECKED	
	ALIGNMENT CHECKED	
	STRUCTURE NOTATIONS CHECKED	
	NOTE BOOK NO.	
	CARD FILE NAME	

PROFILE	SURVEYED	DATE
	PLOTTED	
	GRADES CHECKED	
	ALIGNMENT CHECKED	
	STRUCTURE NOTATIONS CHECKED	
	NOTE BOOK NO.	
	CARD FILE NAME	

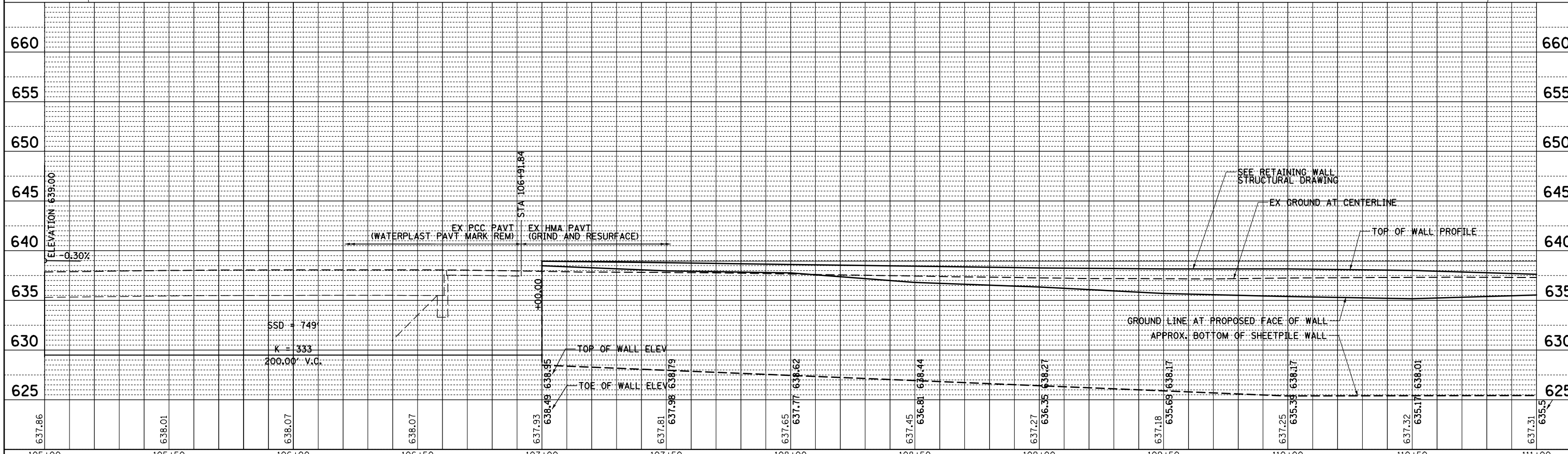
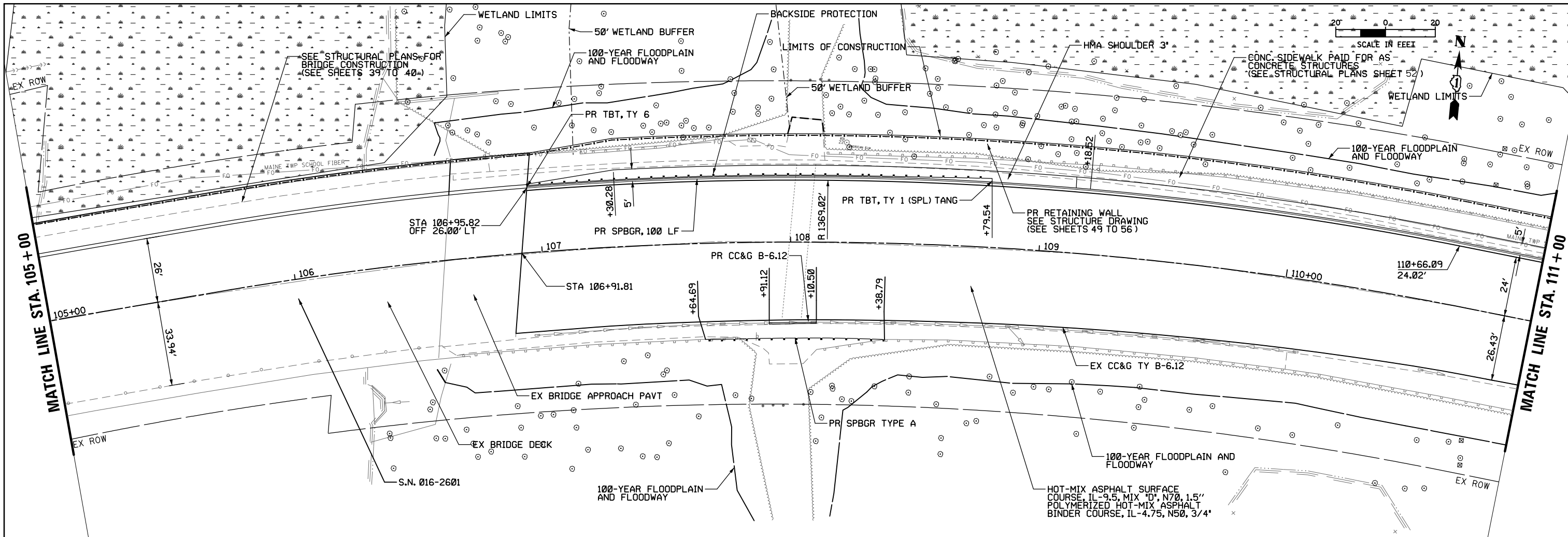

FILE NAME =	USER NAME = mthomas	DESIGNED -	REVISED -
N:\DESPLAINS\190138-00003\Civil\RPP-0AKTON\190138-03_02.shd		DRAWN -	REVISED -
Default	PLOT SCALE = 48"	CHECKED -	REVISED -
	PLOT DATE = 11/8/2022	DATE -	REVISED -

**STATE OF ILLINOIS
DEPARTMENT OF TRANSPORTATION**

**DAKTON STREET SIDEPATH
PROPOSED PLAN & PROFILE**

F.A. RTE.	SECTION	COUNTY	TOTAL SHEETS	SHEET NO.
	20-00224-00-BT	COOK	89	23
CONTRACT NO. 61J19				
ILLINOIS FED. AID PROJECT				

SCALE: SHEET OF SHEETS STA. TO STA.

PLAN	SURVEYED	DATE
	PLOTTED	
	ALIGNED	
	CHECKED	
	FILED	
	NO.	
	FILE NAME	

PROFILE	SURVEYED	DATE
	PLOTTED	
	GRADES CHECKED	
	STRUCTURE	
	NOTATIS CHFD	
	NO.	
	FILE NAME	

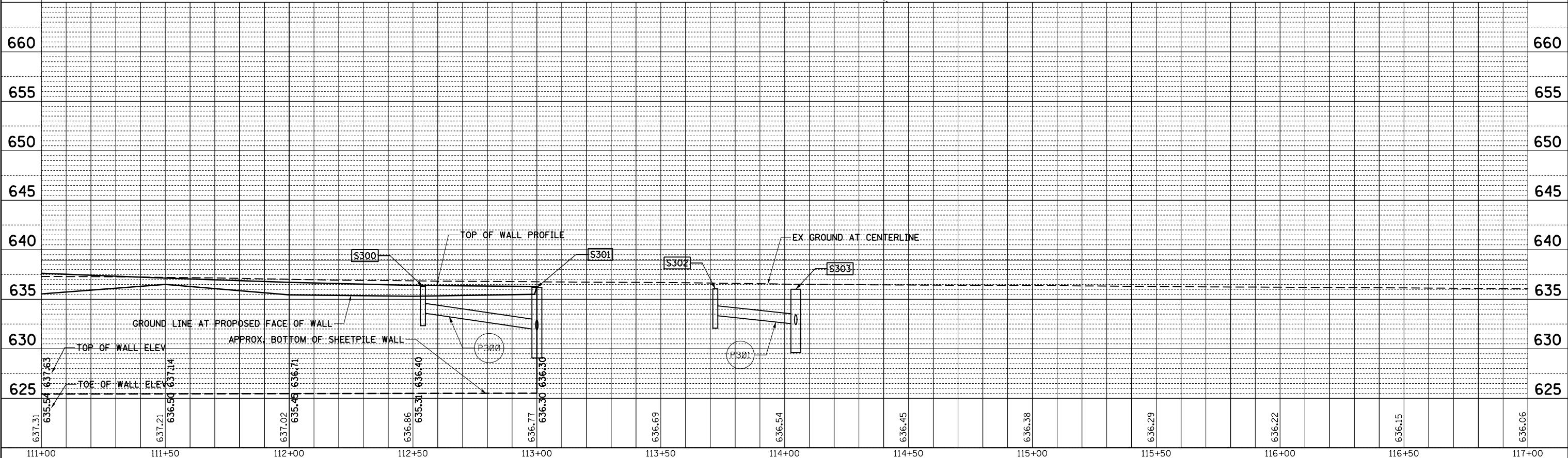
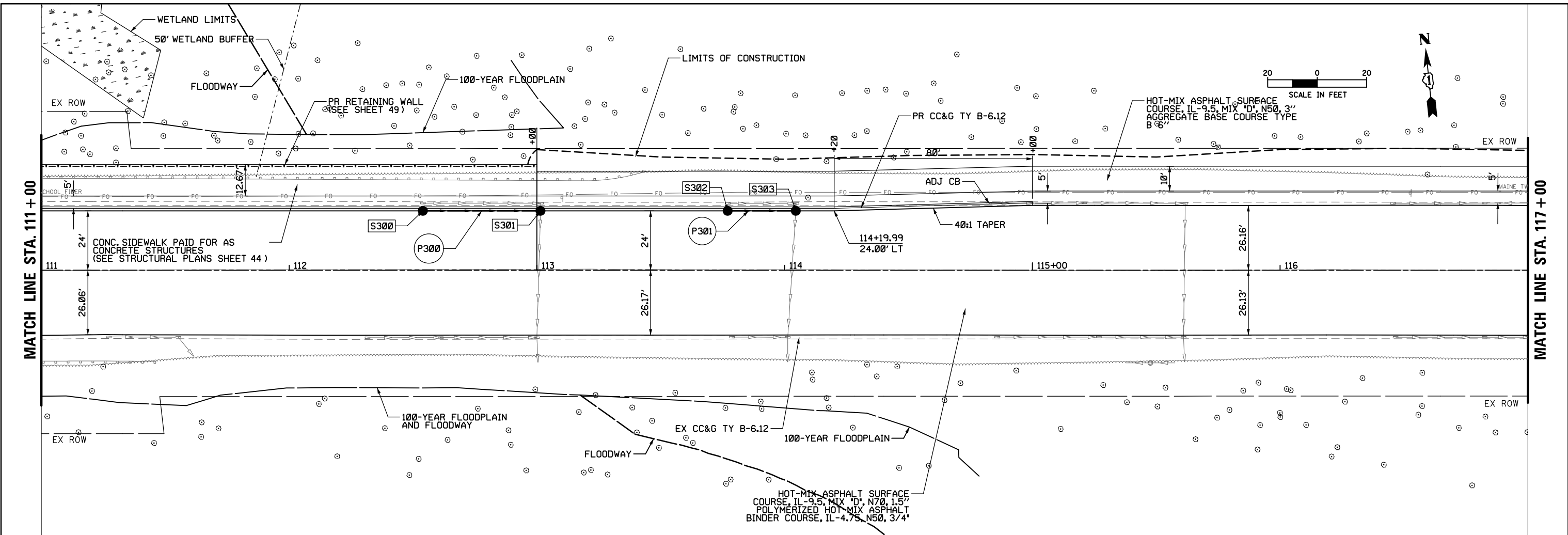

FILE NAME =	USER NAME = mthomas	DESIGNED -	REVISED -
N:\DESPLAINE\190138.00003\Civil\RPP_OAKTON\190138-03.03.shd		DRAWN -	REVISED -
Default	PLOT SCALE = 48"	CHECKED -	REVISED -
	PLOT DATE = 11/8/2022	DATE -	REVISED -

**STATE OF ILLINOIS
DEPARTMENT OF TRANSPORTATION**

**OAKTON STREET SIDEPATH
PROPOSED PLAN & PROFILE**

SCALE: SHEET OF SHEETS STA. TO STA.

F.A. RTE.	SECTION	COUNTY	TOTAL SHEETS	SHEET NO.
	20-00224-00-BT	COOK	89	24
CONTRACT NO. 61J19				
ILLINOIS FED. AID PROJECT				

PLAN	SURVEYED	DATE
	PLOTTED	
	ALIGNMENT CHECKED	
	NOTE BOOK NO.	
	CADD FILE NAME	

PROFILE	SURVEYED	DATE
	PLOTTED	
	GRADES CHECKED	
	NOTE BOOK NO.	
	STRUCTURE NOTATION	

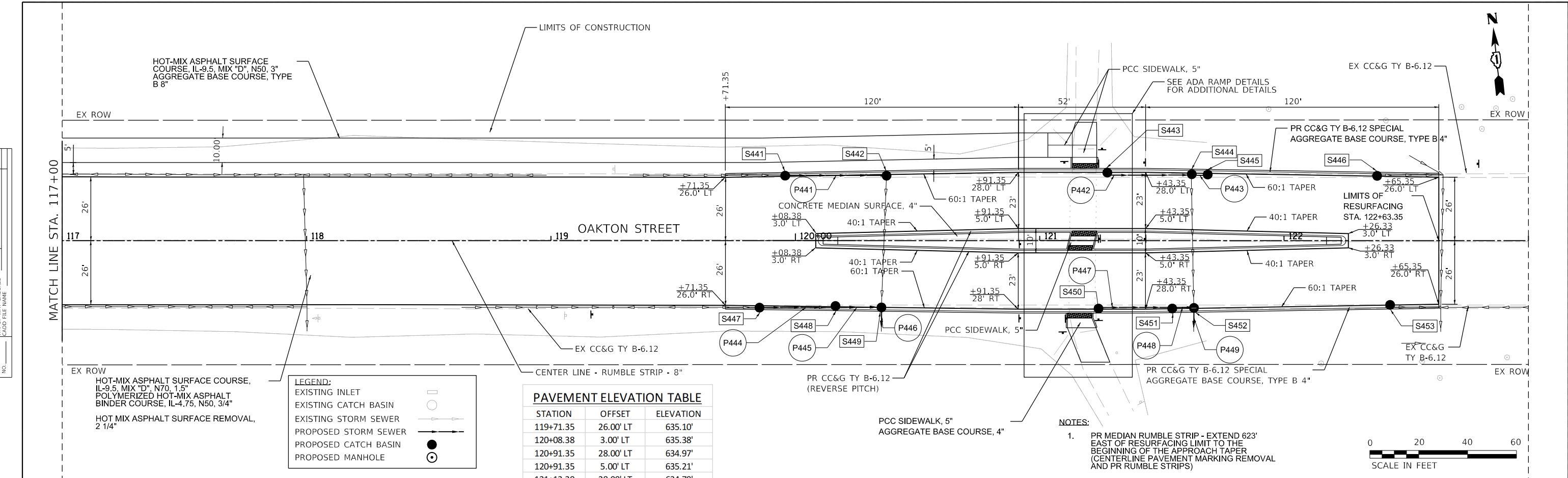

LEGEND:

EXISTING INLET	
EXISTING CATCH BASIN	
EXISTING STORM SEWER	
PROPOSED STORM SEWER	
PROPOSED CATCH BASIN	
PROPOSED MANHOLE	

PAVEMENT ELEVATION TABLE

STATION	OFFSET	ELEVATION
119+71.35	26.00' LT	635.10'
120+08.38	3.00' LT	635.38'
120+91.35	28.00' LT	634.97'
120+91.35	5.00' LT	635.21'
121+13.30	28.00' LT	634.79'
121+23.30	28.00' LT	634.75'
121+43.35	28.00' LT	634.77'
121+43.35	5.00' LT	635.08'
122+26.33	3.00' LT	635.17'
122+65.35	26.00' LT	634.70'
119+71.35	26.00' LT	635.02'
120+08.38	3.00' LT	635.36'
120+91.35	5.00' LT	635.20'
120+91.35	28.00' LT	634.87'
121+11.40	28.00' LT	634.90'
121+21.40	28.00' LT	634.87'
121+43.35	5.00' LT	635.05'
121+43.35	28.00' LT	634.68'
122+26.33	3.00' LT	635.17'
122+65.35	26.00' LT	634.57'

- NOTES:**
- PR MEDIAN RUMBLE STRIP - EXTEND 623' EAST OF RESURFACING LIMIT TO THE BEGINNING OF THE APPROACH TAPER (CENTERLINE PAVEMENT MARKING REMOVAL AND PR RUMBLE STRIPS)
 - IF REQUIRED, CONTRACTOR SHALL CONSTRUCT A CONCRETE COLLAR TO CONNECT THE EXISTING AND PROPOSED SEWER. ENGINEER SHALL DETERMINE WHETHER THE COLLAR IS REQUIRED. THE COST OF THE CONCRETE COLLAR SHALL BE INCLUDED IN THE CONTRACT UNIT PRICE OF THE STORM SEWER OF THE TYPE AND SIZE SPECIFIED.
 - FOR PROPOSED STORM SEWER AND DRAINAGE STRUCTURE SCHEDULES, SEE SHEET 17.

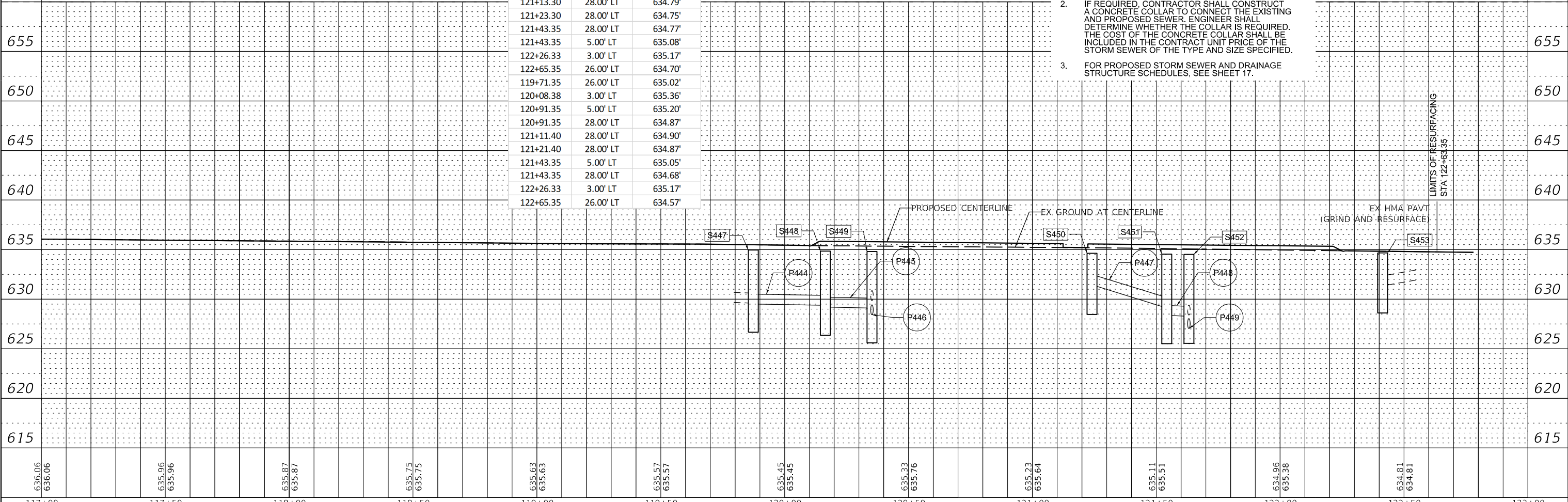

MODEL: SPODELNAME
FILE NAME: SFILES

USER NAME = _USER_	DESIGNED -	REVISED -
PLOT SCALE = 1:40	DRAWN -	REVISED -
PLOT DATE = 11/16/2022	CHECKED -	REVISED -
	DATE -	REVISED -

**STATE OF ILLINOIS
DEPARTMENT OF TRANSPORTATION**

**OAKTON STREET SIDEPATH
PROPOSED PLAN & PROFILE**

SCALE: SHEET OF SHEETS STA. TO STA.

F.A. RTE.	SECTION	COUNTY	TOTAL SHEETS	SHEET NO.
	20-00224-00-BT	COOK	89	25
CONTRACT NO. 61J19				
ILLINOIS FED. AID PROJECT				

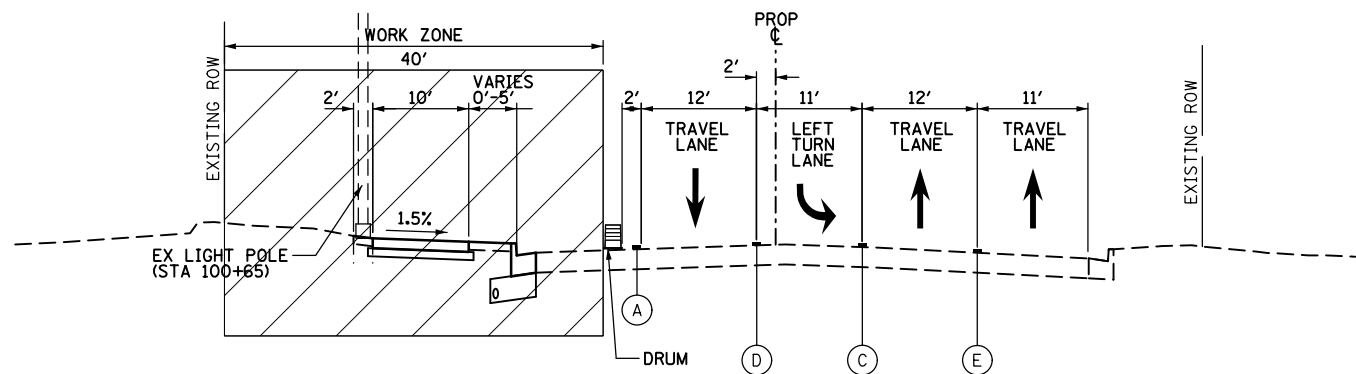

OAKTON STREET
MOT STAGE 1 TYPICAL SECTION
STA 100+31.56 TO STA 100+80.34

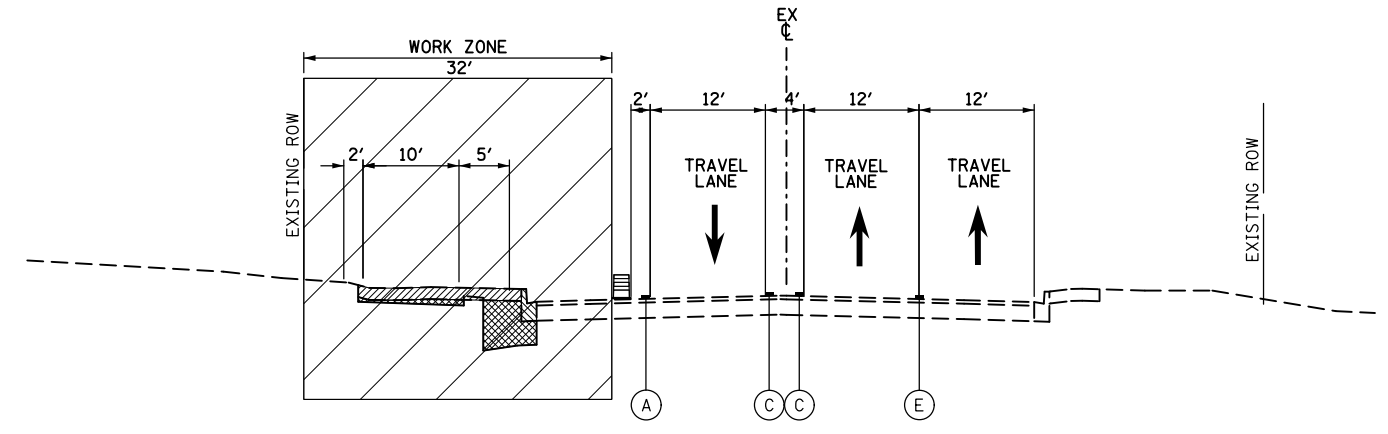

OAKTON STREET
MOT STAGE 1 TYPICAL SECTION
STA 119+71.35 TO STA 122+63.35

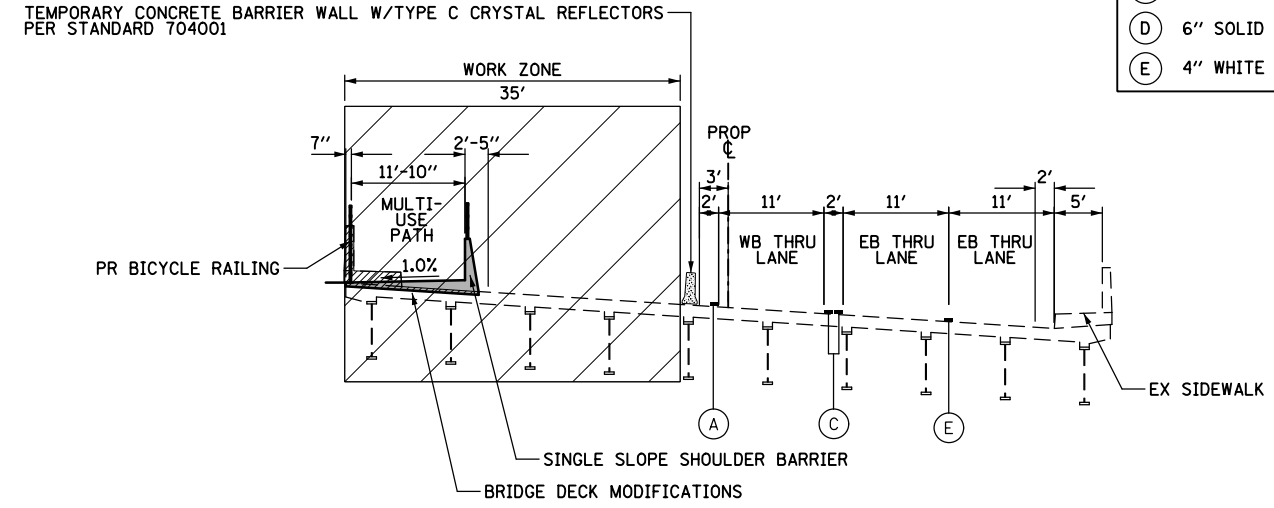

OAKTON STREET
MOT STAGE 1 TYPICAL SECTION
STA 104+28.03 TO STA 106+91.88

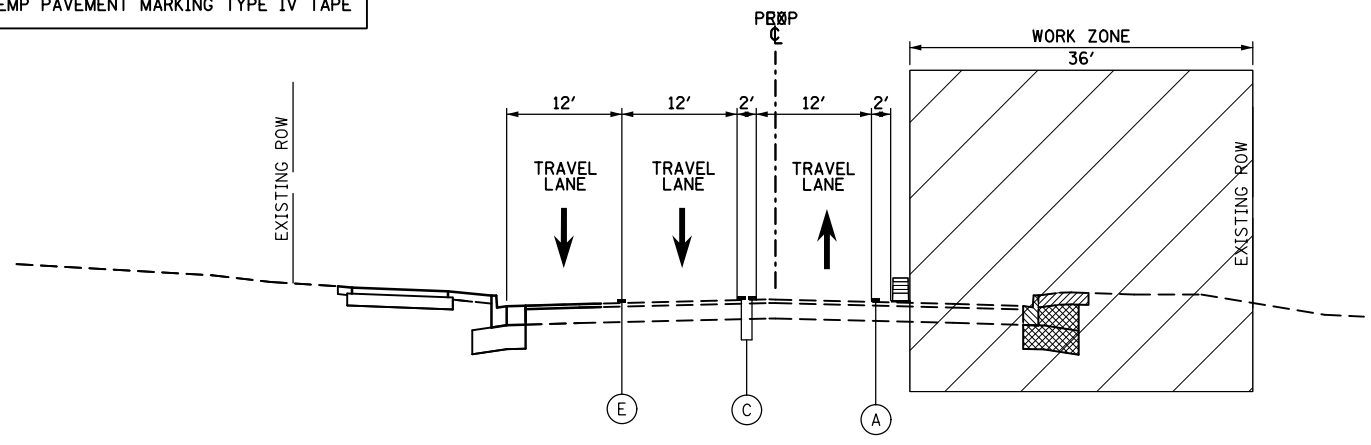

OAKTON STREET
MOT STAGE 2 TYPICAL SECTION
STA 119+71.35 TO STA 122+63.35

- LEGEND**
- (A) 4" SOLID WHITE TEMP PAVEMENT MARKING TYPE IV TAPE
 - (B) 4" SOLID YELLOW TEMP PAVEMENT MARKING TYPE IV TAPE
 - (C) 4" DOUBLE YELLOW @ 11" C-C TEMP PAVEMENT MARKING TYPE IV TAPE
 - (D) 6" SOLID WHITE TEMP PAVEMENT MARKING TYPE IV TAPE
 - (E) 4" WHITE (10' DASH, 30' SKIP) TEMP PAVEMENT MARKING TYPE IV TAPE

CONSTRUCTION STAGING

STAGE 1 NORTH SIDE OF OAKTON CONSTRUCTION

1. SHIFT TRAFFIC AS SHOWN ON THE STAGE 1 MAINTENANCE OF TRAFFIC SHEETS.
2. PLACE AND MAINTAIN SEDIMENT AND EROSION CONTROL MEASURES PER THE STORM WATER POLLUTION PREVENTION PLAN AND AS DIRECTED BY THE ENGINEER.
3. REMOVE AND PRUNE TREES. CONSTRUCT PROPOSED STORM SEWER, CURB AND GUTTER, BRIDGE IMPROVEMENTS, RETAINING WALL AND BIKE PATH ON THE NORTH SIDE OF OAKTON STREET.

STAGE 2 SOUTH SIDE OF OAKTON CONSTRUCTION

1. SHIFT TRAFFIC AS SHOWN ON STAGE 2 MAINTENANCE OF TRAFFIC SHEETS.
2. REMOVE THE PAVEMENT AND CONSTRUCT THE DRAINAGE, CURB AND GUTTER AND SIDEWALK.

STAGE 3 MEDIAN CONSTRUCTION AT DES PLAINES RIVER TRAIL CROSSING

1. SHIFT TRAFFIC AS SHOWN ON STAGE 3 MAINTENANCE OF TRAFFIC SHEETS.
2. REMOVE THE PAVEMENT AND CONSTRUCT THE MEDIAN, INCLUDING CURB AND GUTTER, MEDIAN SURFACE AND SIDEWALK.

STAGE 4 MILL AND RESURFACE

1. MILL AND RESURFACE EXISTING ASPHALT.
2. PLACE FINAL PAVEMENT MARKINGS.
3. COMPLETE ANY REMAINING PUNCH LIST ITEMS.

MOT GENERAL NOTES

1. CHANGEABLE MESSAGE SIGNS SHALL BE INSTALLED TWO WEEKS PRIOR TO ALL TRAFFIC STAGE CHANGES ON EACH APPROACH OF THE EFFECTED ROADWAY TO WARN MOTORISTS OF THE UPCOMING EVENT. THE SIGNS SHALL BE REMOVED TWO WEEKS THEREAFTER UNLESS THE SIGNS ARE NEEDED AGAIN FOR A SUBSEQUENT FUTURE EVENT THAT WILL OCCUR WITHIN 2 WEEKS ON THE SAME APPROACH OF THE EFFECTED ROADWAY. THE SIGN LOCATIONS SHALL BE DETERMINED BY THE ENGINEER.
2. DROP-OFFS GREATER THAN 24 INCHES SHALL NOT BE LEFT UNFILLED OVERNIGHT.
3. MAINTENANCE OF TRAFFIC WILL INCLUDE TEMPORARY DRIVEWAY SIGNING AS DIRECTED BY THE ENGINEER. THE COST WILL BE INCLUDED IN THE UNIT PRICE OF TRAFFIC CONTROL AND PROTECTION, (SPECIAL). ALL ENTRANCE SIGNS WILL BE PLACED BY THE CONTRACTOR.
4. UTILITY TRENCHES SHALL BE COVERED OR FILLED AT THE END OF EACH DAY. THIS WORK SHALL BE INCLUDED IN THE COST OF TRAFFIC CONTROL AND PROTECTION, (SPECIAL).
5. ALL SIGNAGE TO BE IN ACCORDANCE WITH MANUAL ON UNIFORM TRAFFIC CONTROL DEVICES (MUTCD). MAINTENANCE OF TRAFFIC SHOWN IS THE MINIMUM REQUIRED; THE CONTRACTOR SHALL PROVIDE ADDITIONAL TRAFFIC CONTROL MEASURES AS DIRECTED BY THE ENGINEER. THIS WORK WILL BE INCLUDED IN THE COST OF TRAFFIC CONTROL AND PROTECTION, (SPECIAL).
6. THE DES PLAINES RIVER TRAIL MUST REMAIN OPEN AT ALL TIMES EXCEPT FOR 7 CALENDAR DAYS OF CLOSURE PER STAGE AS APPROVED BY THE ENGINEER. ANY AGGREGATE, SIGNAGE, BARRICADES AND TEMPORARY FENCING NECESSARY TO KEEP THE TRAIL OPEN SHALL BE INCLUDED IN THE COST OF TRAFFIC CONTROL AND PROTECTION, (SPECIAL). PAM SIELSKI (708-771-1355) AT THE FOREST PRESERVE DISTRICT OF COOK COUNTY SHALL BE NOTIFIED AT LEAST 14 CALENDAR DAYS PRIOR TO CLOSING THE TRAIL.

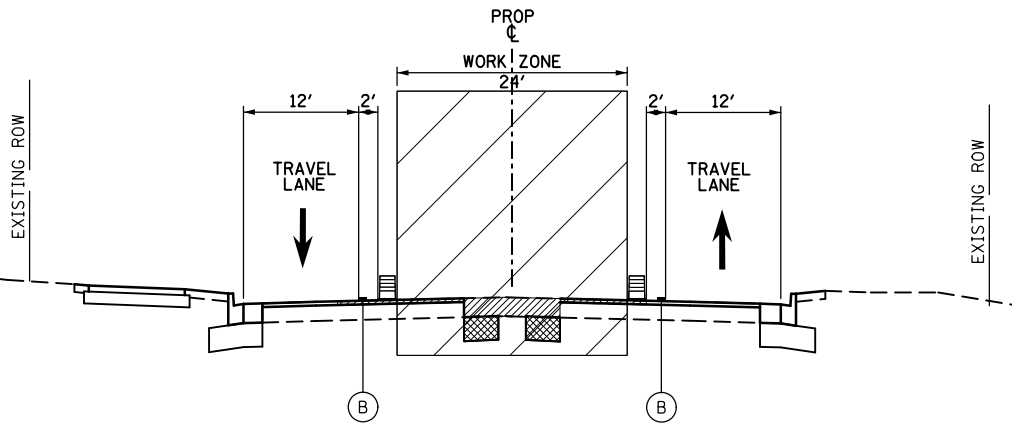

OAKTON STREET
MOT STAGE 3 TYPICAL SECTION
STA 119+71.35 TO STA 122+63.35

FILE NAME =	USER NAME = mthomas	DESIGNED -	REVISED -
N:\DESPLAINES\190138.00003\Civil\MOT.TYP	190138.00003.dgn	DRAWN -	REVISED -
Default	PLOT SCALE = 28'	CHECKED -	REVISED -
	PLOT DATE = 11/8/2022	DATE -	REVISED -

**STATE OF ILLINOIS
DEPARTMENT OF TRANSPORTATION**

**OAKTON STREET SIDEPATH
MAINTENANCE OF TRAFFIC
GENERAL NOTES AND TYPICAL SECTIONS**

SCALE: SHEET OF SHEETS STA. TO STA.

F.A. RTE.	SECTION	COUNTY	TOTAL SHEETS	SHEET NO.
	20-00224-00-BT	COOK	89	26
CONTRACT NO. 61J19				
ILLINOIS FED. AID PROJECT				

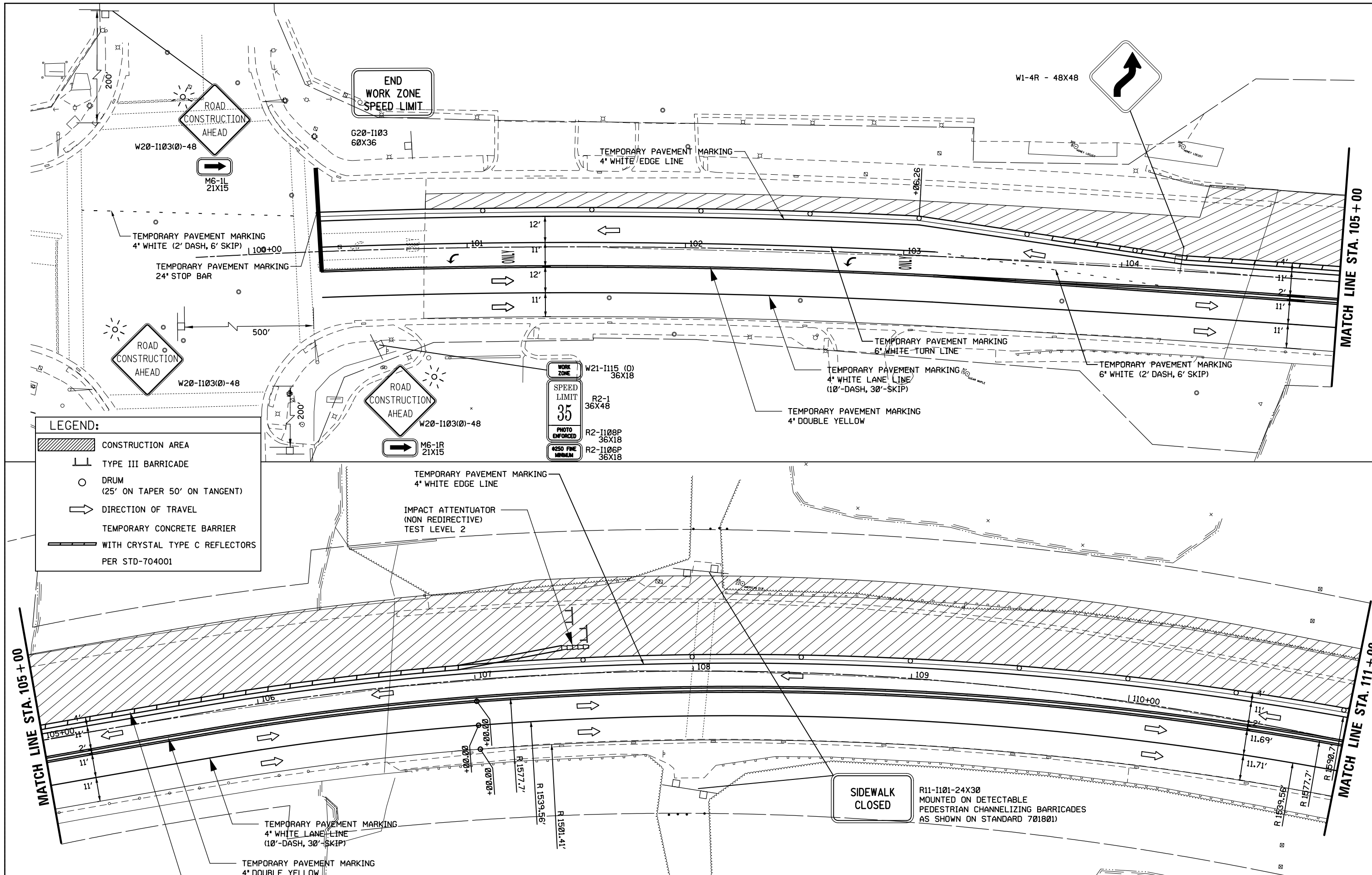

LEGEND:

	CONSTRUCTION AREA
	TYPE III BARRICADE
	DRUM (25' ON TAPER 50' ON TANGENT)
	DIRECTION OF TRAVEL
	TEMPORARY CONCRETE BARRIER WITH CRYSTAL TYPE C REFLECTORS PER STD-704001

FILE NAME =	USER NAME = mthomas	DESIGNED -	REVISED -
N:\DESPLAINS\190138.00003\Civil\MOT_SHT	190138-03_01.sht	DRAWN -	REVISED -
Default	PLOT SCALE = 20'	CHECKED -	REVISED -
	PLOT DATE = 11/8/2022	DATE -	REVISED -

**STATE OF ILLINOIS
DEPARTMENT OF TRANSPORTATION**

**OAKTON STREET SIDE PATH
MAINTENANCE OF TRAFFIC STAGE 1**

SCALE: SHEET OF SHEETS STA. TO STA.

F.A. RTE.	SECTION	COUNTY	TOTAL SHEETS	SHEET NO.
	20-00224-00-BT	COOK	89	27
CONTRACT NO. 61J19				
ILLINOIS FED. AID PROJECT				

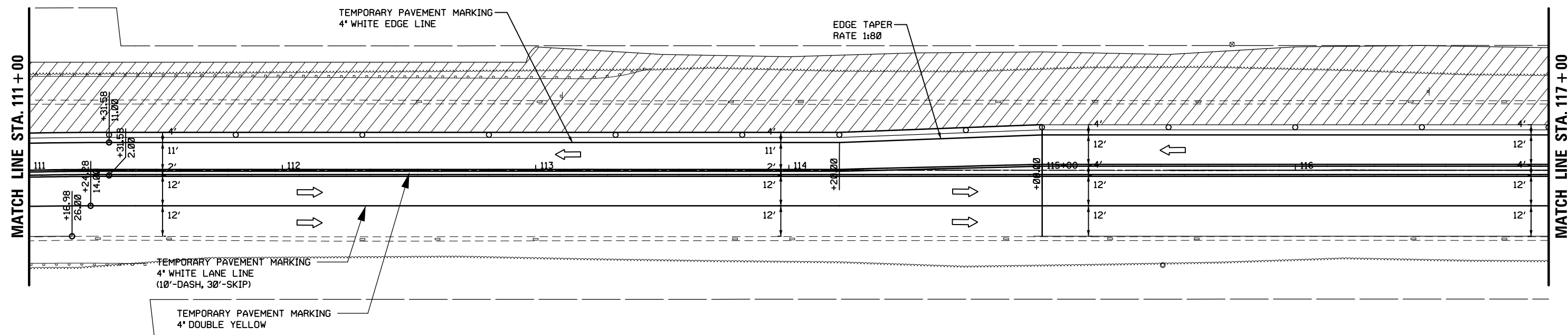

LEGEND:

	CONSTRUCTION AREA
	TYPE III BARRICADE
	DRUM (25' ON TAPER 50' ON TANGENT)
	DIRECTION OF TRAVEL
	TEMPORARY CONCRETE BARRIER
	WITH CRYSTAL TYPE C REFLECTORS PER STD-704001

DES PLAINES RIVER TRAIL CLOSURE DATE SIGNAGE TO BE POSTED AT THE DES PLAINES RIVER TRAIL CROSSINGS OF ALGONGUIN ROAD AND TOUHY AVE AT LEAST 14 DAYS PRIOR TO THE CLOSURE TAKING PLACE. SEE MAINTENANCE OF TRAFFIC GENERAL NOTES FOR MORE INFORMATION.

TRAIL CLOSED FROM MMM ** THRU MMM **
 24X30 MOUNTED ON DETECTABLE PEDESTRIAN CHANNELIZING BARRICADES AS SHOWN ON STANDARD 701801

TRAIL CLOSED
 R11-1101-24X30 MOUNTED ON DETECTABLE PEDESTRIAN CHANNELIZING BARRICADES AS SHOWN ON STANDARD 701801

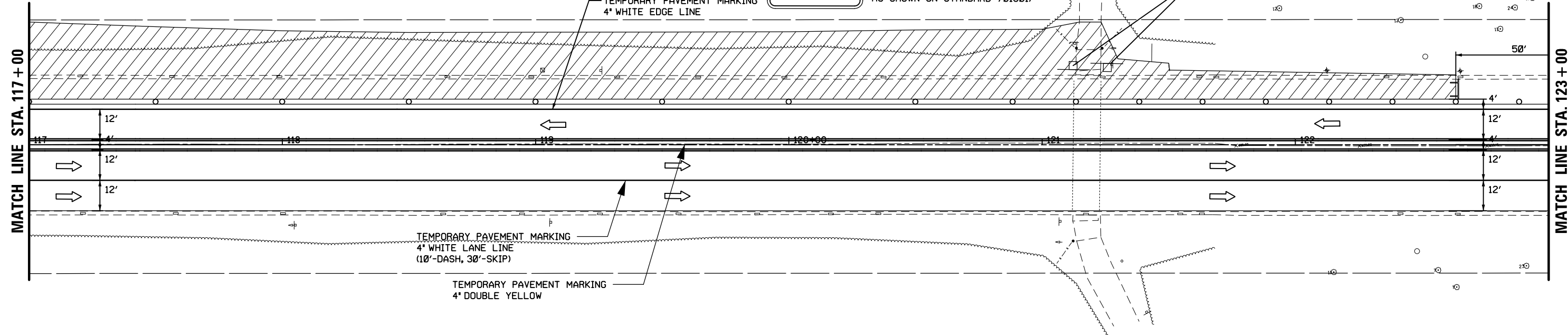

FILE NAME = N:\DESPLAINES\190138.00003\Civil\1\NOT_SHT	USER NAME = mthomas	DESIGNED -	REVISED -
190138-03_01.sht		DRAWN -	REVISED -
PLOT SCALE = 20'		CHECKED -	REVISED -
PLOT DATE = 11/8/2022		DATE -	REVISED -

**STATE OF ILLINOIS
DEPARTMENT OF TRANSPORTATION**

**OAKTON STREET SIDE PATH
MAINTENANCE OF TRAFFIC STAGE 1**

SCALE: SHEET OF SHEETS STA. TO STA.

F.A. RTE.	SECTION	COUNTY	TOTAL SHEETS	SHEET NO.
	20-00224-00-BT	COOK	89	28
CONTRACT NO. 61J19				
ILLINOIS FED. AID PROJECT				

MATCH LINE STA. 123+00

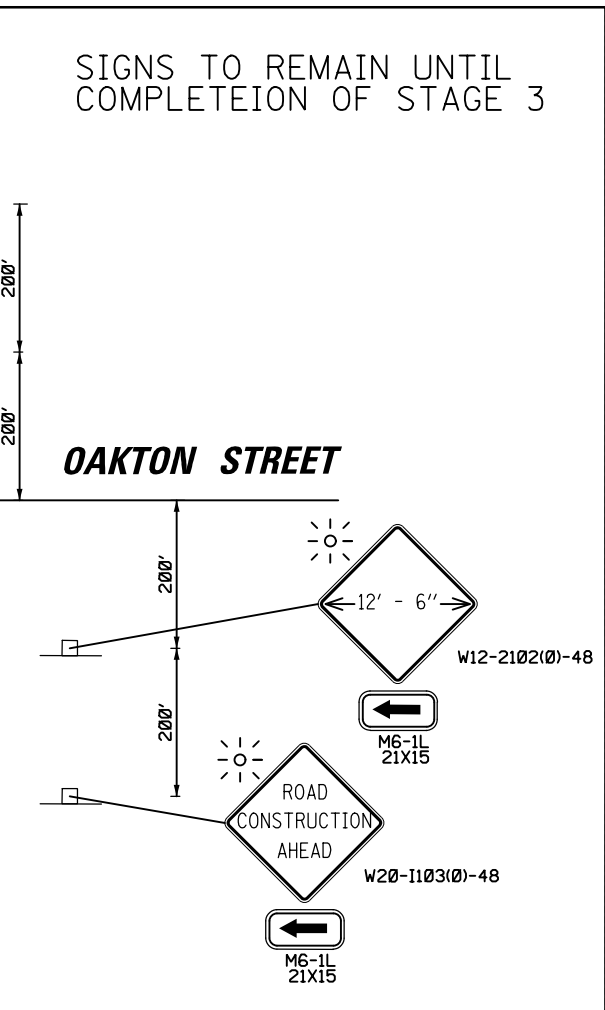
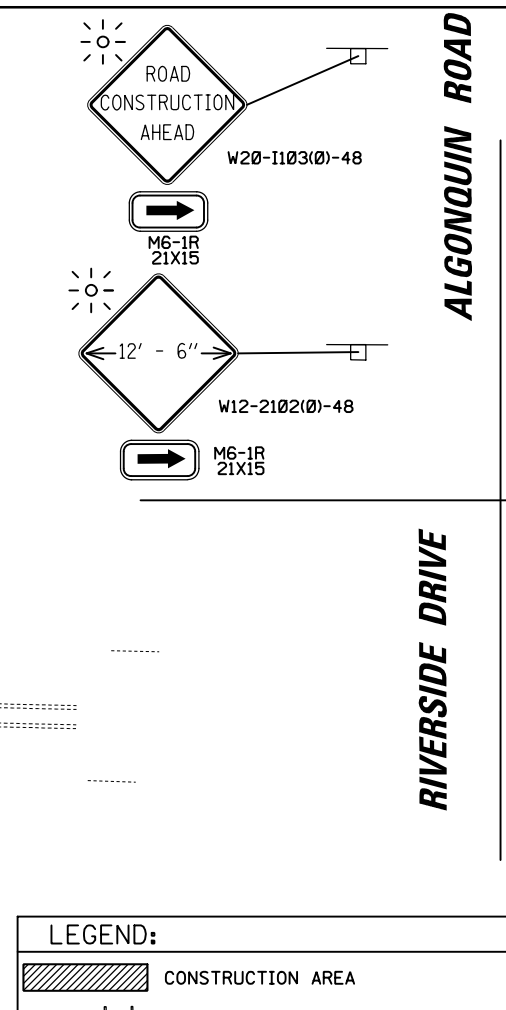
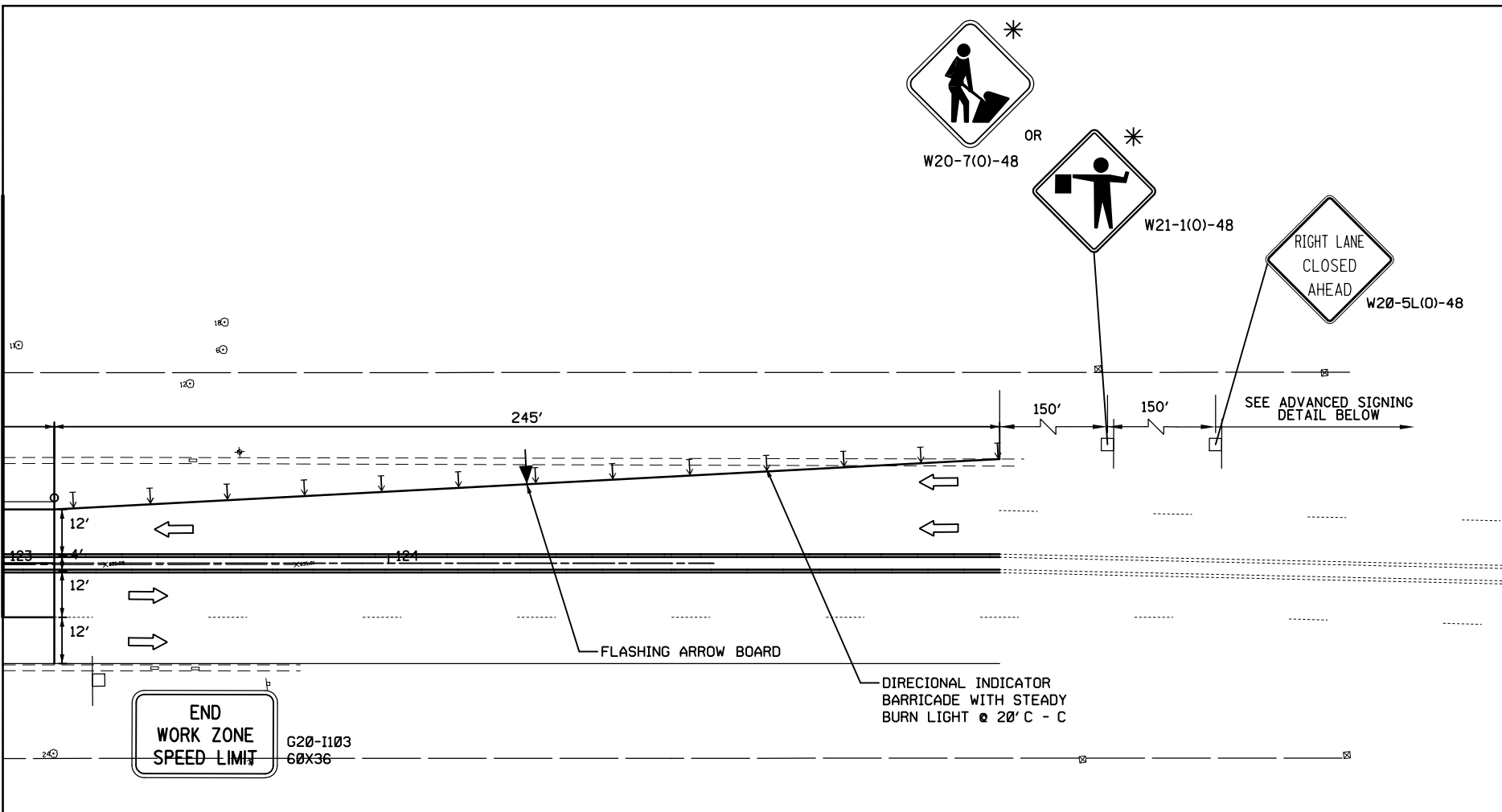

SIGNS TO REMAIN UNTIL COMPLETEION OF STAGE 3

LEGEND:

- CONSTRUCTION AREA
- TYPE III BARRICADE
- DRUM (25' ON TAPER 50' ON TANGENT)
- DIRECTION OF TRAVEL
- TEMPORARY CONCRETE BARRIER WITH CRYSTAL TYPE C REFLECTORS PER STD-704001

* MUST BE REMOVED OR KNOCKED DOWN WHEN WORKERS OR FLAGGERS ARE NOT PRESENT FOR MORE THAN ONE HOUR

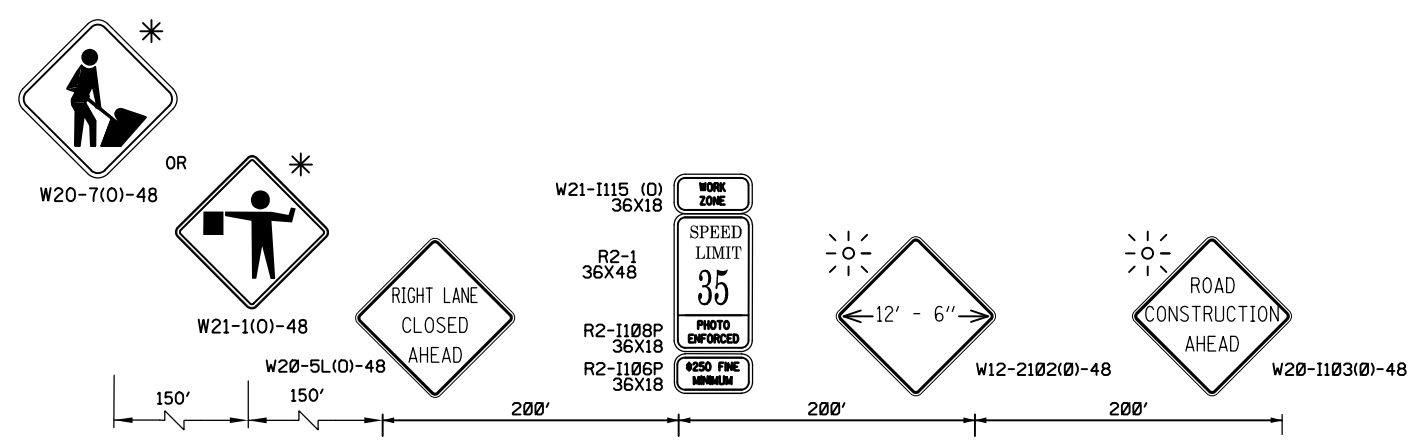

FILE NAME = N:\DESPLAINS\190138.00003\Civil\MOT_SHT	USER NAME = mthomas	DESIGNED -	REVISED -
Default	PLOT DATE = 11/8/2022	DRAWN -	REVISED -
		CHECKED -	REVISED -
		DATE -	REVISED -

STATE OF ILLINOIS
DEPARTMENT OF TRANSPORTATION

OAKTON STREET SIDE PATH MAINTENANCE OF TRAFFIC STAGE 1

SCALE: SHEET OF SHEETS STA. TO STA.

F.A. RTE.	SECTION	COUNTY	TOTAL SHEETS	SHEET NO.
	20-00224-00-BT	COOK	89	29
CONTRACT NO. 61J19				
ILLINOIS FED. AID PROJECT				

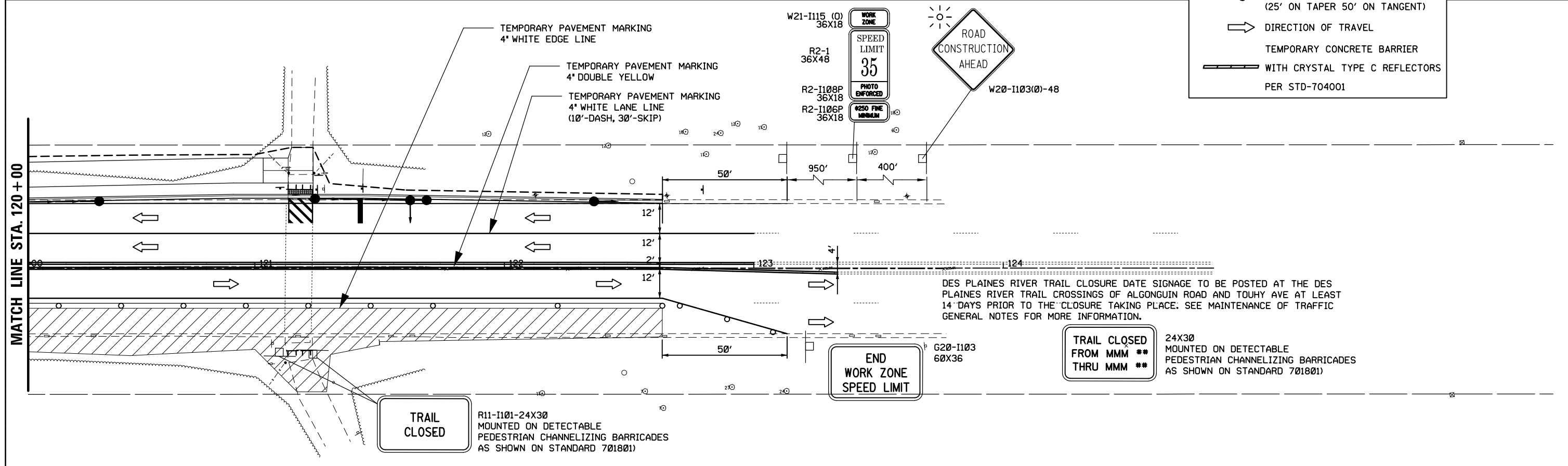
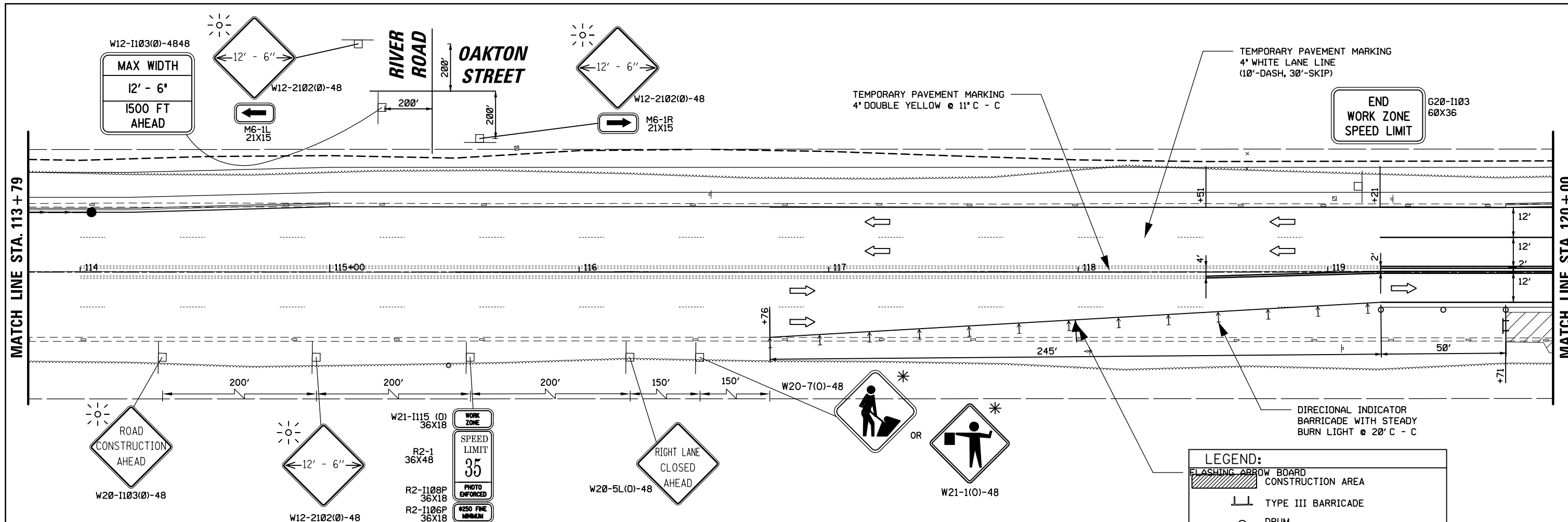

LEGEND:

- FLASHING ARROW BOARD
- CONSTRUCTION AREA
- TYPE III BARRICADE
- DRUM (25' ON TAPER 50' ON TANGENT)
- DIRECTION OF TRAVEL
- TEMPORARY CONCRETE BARRIER WITH CRYSTAL TYPE C REFLECTORS PER STD-704001

DES PLAINES RIVER TRAIL CLOSURE DATE SIGNAGE TO BE POSTED AT THE DES PLAINES RIVER TRAIL CROSSINGS OF ALGONGUIN ROAD AND TOUHY AVE AT LEAST 14 DAYS PRIOR TO THE CLOSURE TAKING PLACE. SEE MAINTENANCE OF TRAFFIC GENERAL NOTES FOR MORE INFORMATION.

TRAIL CLOSED FROM MMM ** THRU MMM **
 24X30 MOUNTED ON DETECTABLE PEDESTRIAN CHANNELIZING BARRICADES AS SHOWN ON STANDARD 701801

TRAIL CLOSED
 R11-1101-24X30 MOUNTED ON DETECTABLE PEDESTRIAN CHANNELIZING BARRICADES AS SHOWN ON STANDARD 701801

FILE NAME = N:\DESPLAINES\190138.00003\Civil\MOT_SHT	USER NAME = mthomas	DESIGNED -	REVISED -	STATE OF ILLINOIS DEPARTMENT OF TRANSPORTATION	OAKTON STREET SIDE PATH MAINTENANCE OF TRAFFIC STAGE 2	F.A. RTE.	SECTION	COUNTY	TOTAL SHEETS	SHEET NO.
Default	190138-03_02.sht	DRAWN -	REVISED -			20-00224-00-BT	COOK	89	30	CONTRACT NO. 61J19
	PLOT SCALE = 20'	CHECKED -	REVISED -			ILLINOIS FED. AID PROJECT				
	PLOT DATE = 11/8/2022	DATE -	REVISED -			SCALE:	SHEET	OF	SHEETS	STA.

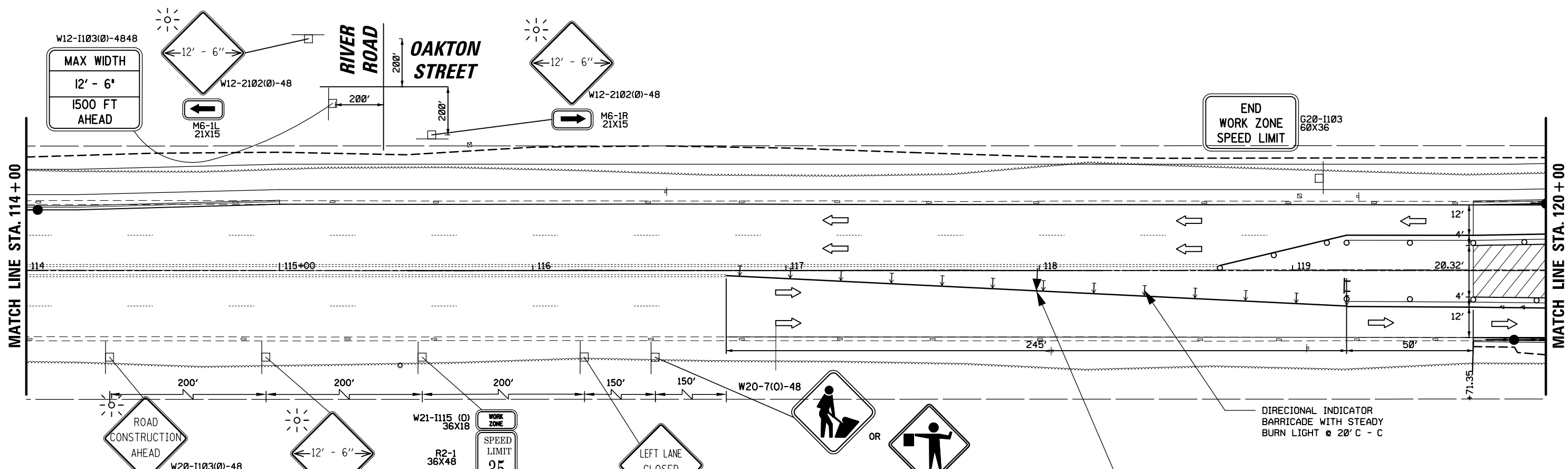

LEGEND:

- CONSTRUCTION AREA
- TYPE III BARRICADE
- DRUM (25' ON TAPER 50' ON TANGENT)
- DIRECTION OF TRAVEL
- TEMPORARY CONCRETE BARRIER WITH CRYSTAL TYPE C REFLECTORS PER STD-704001

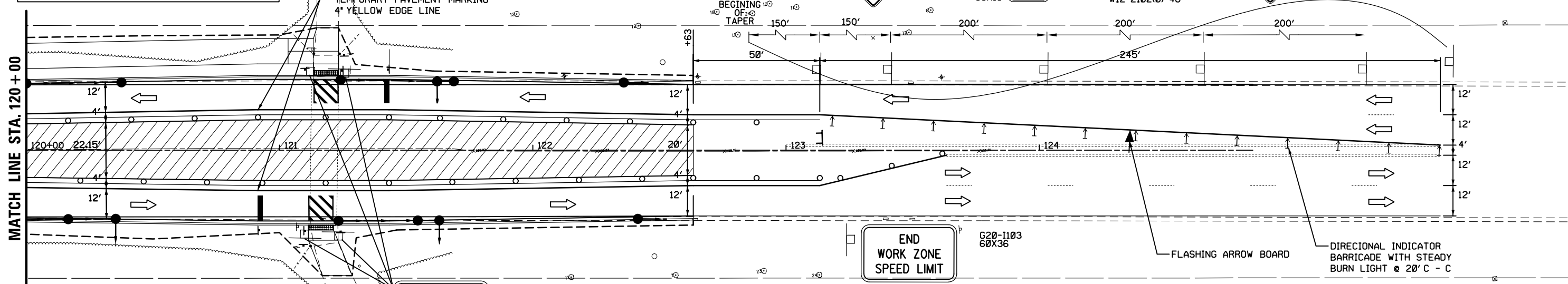

TRAIL CLOSED

R11-1101-24X30 MOUNTED ON DETECTABLE PEDESTRIAN CHANNELIZING BARRICADES AS SHOWN ON STANDARD 701801)

DES PLAINES RIVER TRAIL CLOSURE DATE SIGNAGE TO BE POSTED AT THE DES PLAINES RIVER TRAIL CROSSINGS OF ALGONGUIN ROAD AND TOUHY AVE AT LEAST 14 DAYS PRIOR TO THE CLOSURE TAKING PLACE. SEE MAINTENANCE OF TRAFFIC GENERAL NOTES FOR MORE INFORMATION.

TRAIL CLOSED FROM MMM ** THRU MMM **

24X30 MOUNTED ON DETECTABLE PEDESTRIAN CHANNELIZING BARRICADES AS SHOWN ON STANDARD 701801)

FILE NAME =	USER NAME = mthomas	DESIGNED -	REVISED -
N:\DESPLAINES\190138.000\03\Civil\1\MOT_SHT	190138-03_03.sht	DRAWN -	REVISED -
Default	PLOT SCALE = 20'	CHECKED -	REVISED -
	PLOT DATE = 11/8/2022	DATE -	REVISED -

**STATE OF ILLINOIS
DEPARTMENT OF TRANSPORTATION**

**OAKTON STREET SIDE PATH
MAINTENANCE OF TRAFFIC STAGE 3**

SCALE: SHEET OF SHEETS STA. TO STA.

F.A. RTE.	SECTION	COUNTY	TOTAL SHEETS	SHEET NO.
	20-00224-00-BT	COOK	89	31
CONTRACT NO. 61J19				
ILLINOIS FED. AID PROJECT				

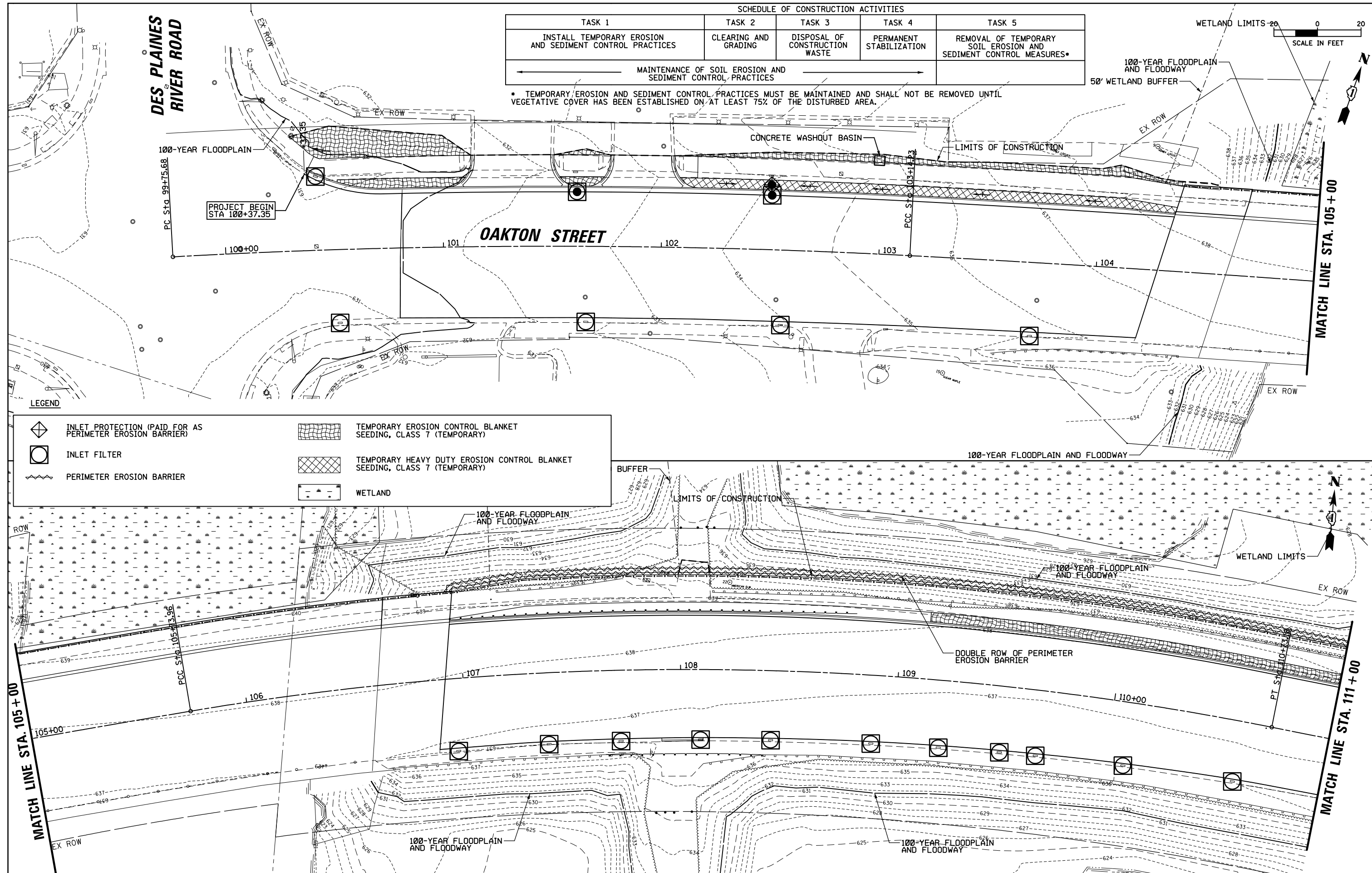

TASK 1	TASK 2	TASK 3	TASK 4	TASK 5
INSTALL TEMPORARY EROSION AND SEDIMENT CONTROL PRACTICES	CLEARING AND GRADING	DISPOSAL OF CONSTRUCTION WASTE	PERMANENT STABILIZATION	REMOVAL OF TEMPORARY SOIL EROSION AND SEDIMENT CONTROL MEASURES*

← MAINTENANCE OF SOIL EROSION AND SEDIMENT CONTROL PRACTICES →

* TEMPORARY EROSION AND SEDIMENT CONTROL PRACTICES MUST BE MAINTAINED AND SHALL NOT BE REMOVED UNTIL VEGETATIVE COVER HAS BEEN ESTABLISHED ON AT LEAST 75% OF THE DISTURBED AREA.

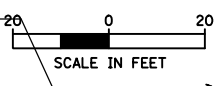

LEGEND	
	INLET PROTECTION (PAID FOR AS PERIMETER EROSION BARRIER)
	INLET FILTER
	PERIMETER EROSION BARRIER
	TEMPORARY EROSION CONTROL BLANKET SEEDING, CLASS 7 (TEMPORARY)
	TEMPORARY HEAVY DUTY EROSION CONTROL BLANKET SEEDING, CLASS 7 (TEMPORARY)
	WETLAND

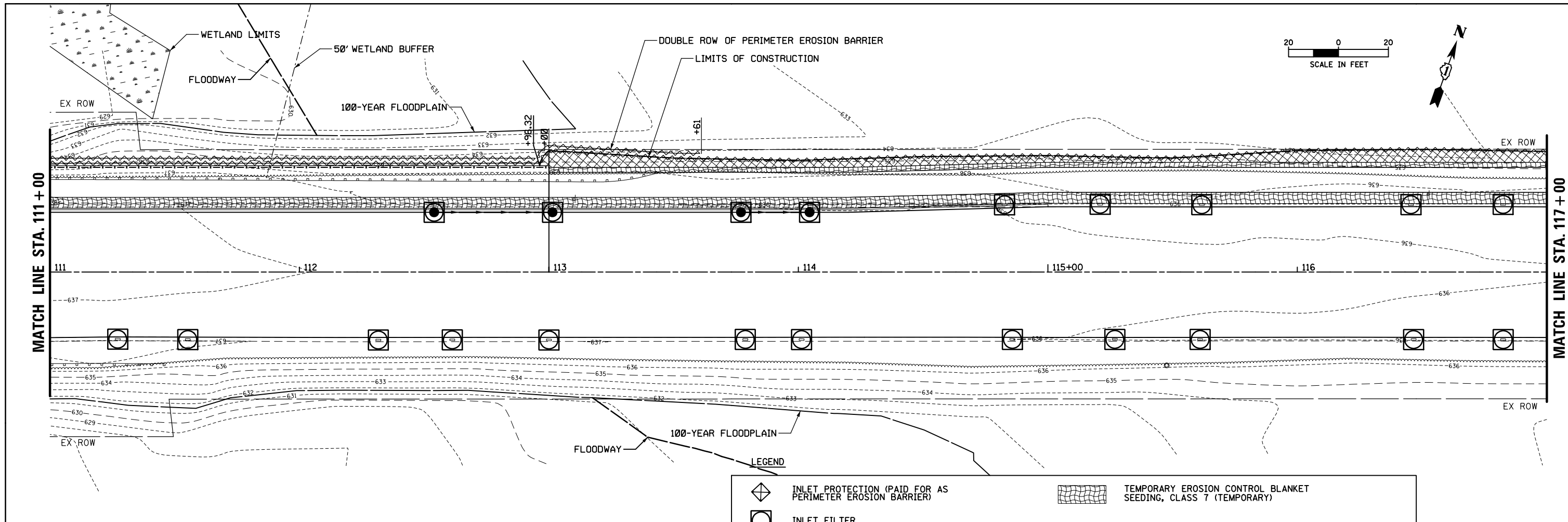

LEGEND

	INLET PROTECTION (PAID FOR AS PERIMETER EROSION BARRIER)		TEMPORARY EROSION CONTROL BLANKET SEEDING, CLASS 7 (TEMPORARY)
	INLET FILTER		TEMPORARY HEAVY DUTY EROSION CONTROL BLANKET SEEDING, CLASS 7 (TEMPORARY)
	PERIMETER EROSION BARRIER		WETLAND

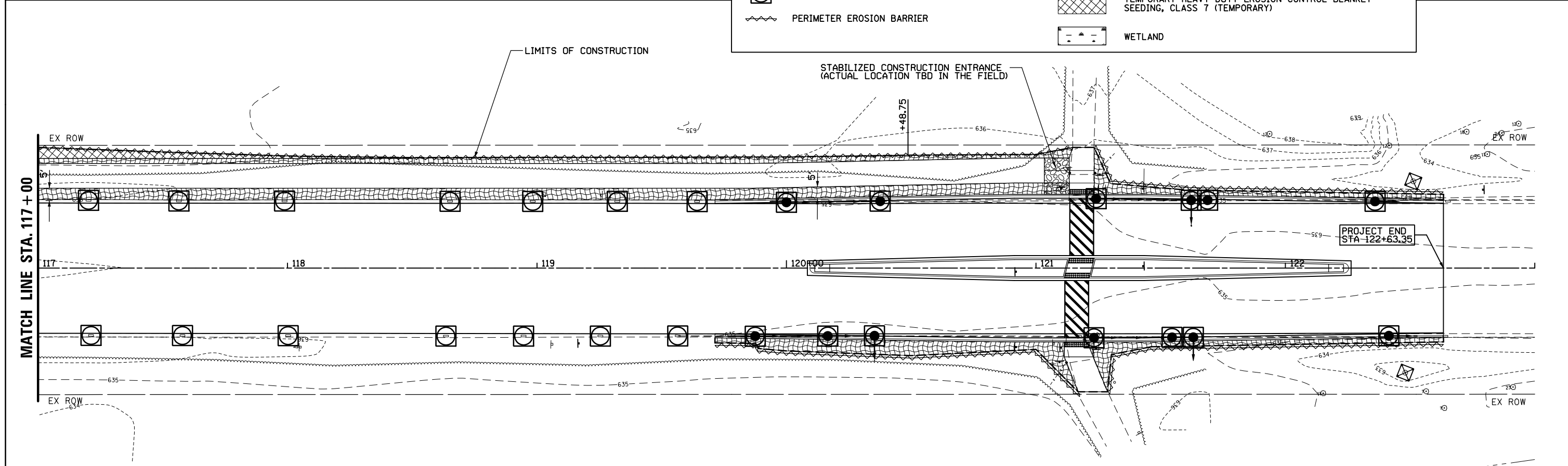

FILE NAME = N:\DESPLAINS\190138.00003\Civil\NECP_04K	USER NAME = mthomas	DESIGNED -	REVISED -	STATE OF ILLINOIS DEPARTMENT OF TRANSPORTATION	OAKTON STREET SIDEPATH EROSION CONTROL PLAN				F.A. RTE.	SECTION	COUNTY	TOTAL SHEETS	SHEET NO.
Default	DN_190138-03_02.sht	DRAWN -	REVISED -		SCALE:	SHEET	OF	SHEETS	STA.	TO	STA.	89	33
	PLOT SCALE = 48"	CHECKED -	REVISED -		CONTRACT NO. 61J19								
	PLOT DATE = 11/8/2022	DATE -	REVISED -		ILLINOIS FED. AID PROJECT								

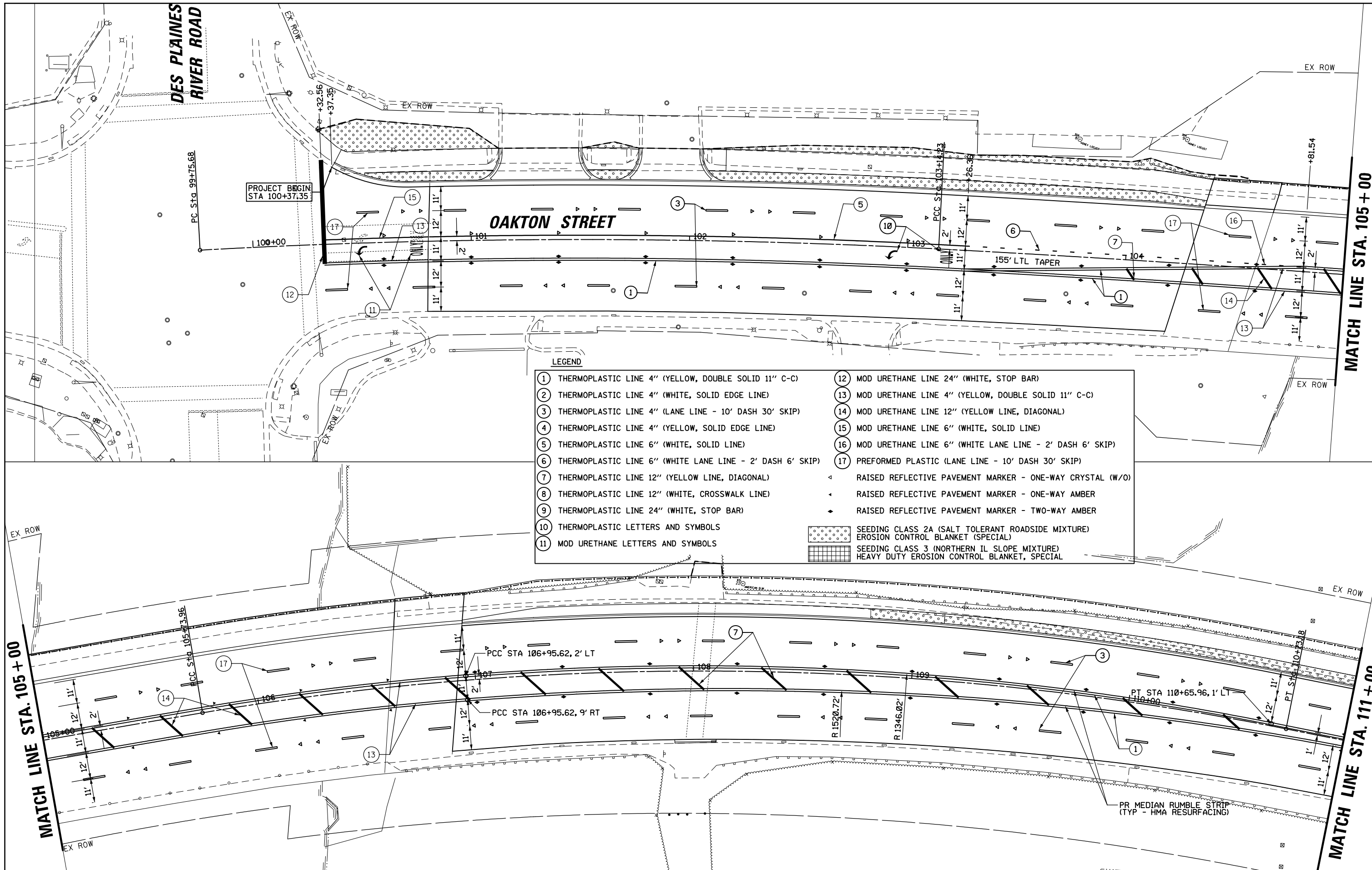

LEGEND

① THERMOPLASTIC LINE 4" (YELLOW, DOUBLE SOLID 11" C-C)	⑫ MOD URETHANE LINE 24" (WHITE, STOP BAR)
② THERMOPLASTIC LINE 4" (WHITE, SOLID EDGE LINE)	⑬ MOD URETHANE LINE 4" (YELLOW, DOUBLE SOLID 11" C-C)
③ THERMOPLASTIC LINE 4" (LANE LINE - 10' DASH 30' SKIP)	⑭ MOD URETHANE LINE 12" (YELLOW LINE, DIAGONAL)
④ THERMOPLASTIC LINE 4" (YELLOW, SOLID EDGE LINE)	⑮ MOD URETHANE LINE 6" (WHITE, SOLID LINE)
⑤ THERMOPLASTIC LINE 6" (WHITE, SOLID LINE)	⑯ MOD URETHANE LINE 6" (WHITE LANE LINE - 2' DASH 6' SKIP)
⑥ THERMOPLASTIC LINE 6" (WHITE LANE LINE - 2' DASH 6' SKIP)	⑰ PREFORMED PLASTIC (LANE LINE - 10' DASH 30' SKIP)
⑦ THERMOPLASTIC LINE 12" (YELLOW LINE, DIAGONAL)	▲ RAISED REFLECTIVE PAVEMENT MARKER - ONE-WAY CRYSTAL (W/O)
⑧ THERMOPLASTIC LINE 12" (WHITE, CROSSWALK LINE)	▲ RAISED REFLECTIVE PAVEMENT MARKER - ONE-WAY AMBER
⑨ THERMOPLASTIC LINE 24" (WHITE, STOP BAR)	◆ RAISED REFLECTIVE PAVEMENT MARKER - TWO-WAY AMBER
⑩ THERMOPLASTIC LETTERS AND SYMBOLS	▨ SEEDING CLASS 2A (SALT TOLERANT ROADSIDE MIXTURE)
⑪ MOD URETHANE LETTERS AND SYMBOLS	▨ EROSION CONTROL BLANKET (SPECIAL)
	▨ SEEDING CLASS 3 (NORTHERN IL SLOPE MIXTURE)
	▨ HEAVY DUTY EROSION CONTROL BLANKET, SPECIAL

FILE NAME = N:\DESPLAINES\190138.00003\Civil\PMK_OAK	USER NAME = mthomas	DESIGNED -	REVISED -
Default	ON:190138-03.01.sht	DRAWN -	REVISED -
	PLOT SCALE = 48"	CHECKED -	REVISED -
	PLOT DATE = 11/8/2022	DATE -	REVISED -

**STATE OF ILLINOIS
DEPARTMENT OF TRANSPORTATION**

**OAKTON STREET SIDEPATH
PAVEMENT MARKING AND LANDSCAPING PLAN**

SCALE: SHEET OF SHEETS STA. TO STA.

F.A. RTE.	SECTION	COUNTY	TOTAL SHEETS	SHEET NO.
	20-00224-00-BT	COOK	89	34
CONTRACT NO. 61J19				
ILLINOIS FED. AID PROJECT				

MATCH LINE STA. 111 + 00

MATCH LINE STA. 117 + 00

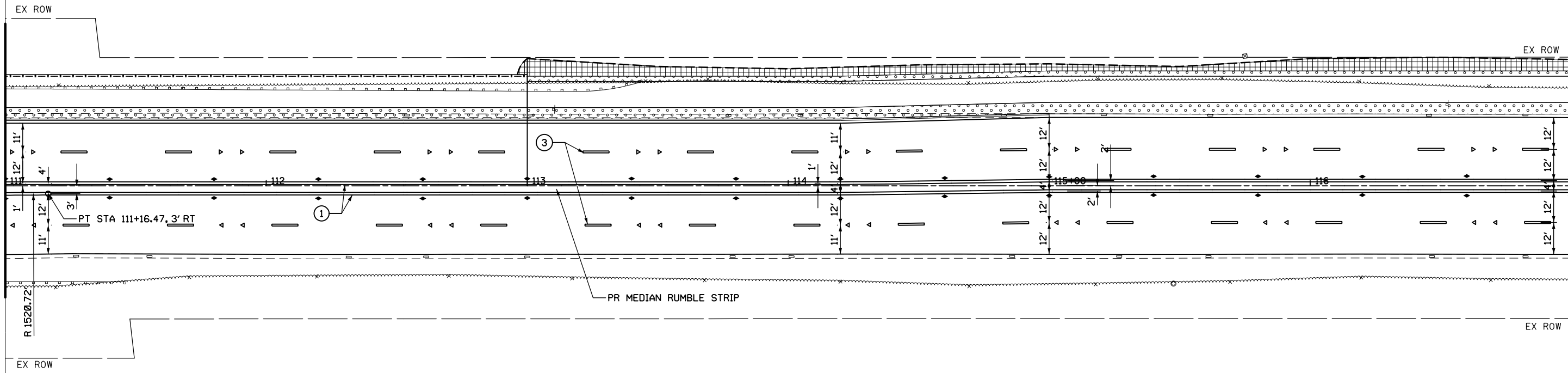

LEGEND

① THERMOPLASTIC LINE 4" (YELLOW, DOUBLE SOLID 11" C-C)	⑫ MOD URETHANE LINE 24" (WHITE, STOP BAR)
② THERMOPLASTIC LINE 4" (WHITE, SOLID EDGE LINE)	⑬ MOD URETHANE LINE 4" (YELLOW, DOUBLE SOLID 11" C-C)
③ THERMOPLASTIC LINE 4" (LANE LINE - 10' DASH 30' SKIP)	⑭ MOD URETHANE LINE 12" (YELLOW LINE, DIAGONAL)
④ THERMOPLASTIC LINE 4" (YELLOW, SOLID EDGE LINE)	⑮ MOD URETHANE LINE 6" (WHITE, SOLID LINE)
⑤ THERMOPLASTIC LINE 6" (WHITE, SOLID LINE)	⑯ MOD URETHANE LINE 6" (WHITE LANE LINE - 2' DASH 6' SKIP)
⑥ THERMOPLASTIC LINE 6" (WHITE LANE LINE - 2' DASH 6' SKIP)	⑰ PREFORMED PLASTIC (LANE LINE - 10' DASH 30' SKIP)
⑦ THERMOPLASTIC LINE 12" (YELLOW LINE, DIAGONAL)	◀ RAISED REFLECTIVE PAVEMENT MARKER - ONE-WAY CRYSTAL (W/O)
⑧ THERMOPLASTIC LINE 12" (WHITE, CROSSWALK LINE)	◀ RAISED REFLECTIVE PAVEMENT MARKER - ONE-WAY AMBER
⑨ THERMOPLASTIC LINE 24" (WHITE, STOP BAR)	◆ RAISED REFLECTIVE PAVEMENT MARKER - TWO-WAY AMBER
⑩ THERMOPLASTIC LETTERS AND SYMBOLS	◻ SEEDING CLASS 2A (SALT TOLERANT ROADSIDE MIXTURE)
⑪ MOD URETHANE LETTERS AND SYMBOLS	◻ EROSION CONTROL BLANKET (SPECIAL)
	◻ SEEDING CLASS 3 (NORTHERN IL SLOPE MIXTURE)
	◻ HEAVY DUTY EROSION CONTROL BLANKET, SPECIAL

FILE NAME =	USER NAME = mthomas	DESIGNED -	REVISED -
N:\DESPLAINS\190138.00003\Civil\PMK_DAK	ON.190138-03.02.sht	DRAWN -	REVISED -
Default	PLOT SCALE = 48"	CHECKED -	REVISED -
	PLOT DATE = 11/8/2022	DATE -	REVISED -

STATE OF ILLINOIS
DEPARTMENT OF TRANSPORTATION

OAKTON STREET SIDEPATH
PAVEMENT MARKING AND LANDSCAPING PLAN

SCALE: SHEET OF SHEETS STA. TO STA.

F.A. RTE.	SECTION	COUNTY	TOTAL SHEETS	SHEET NO.
	20-00224-00-BT	COOK	89	35
CONTRACT NO. 61J19				
ILLINOIS FED. AID PROJECT				

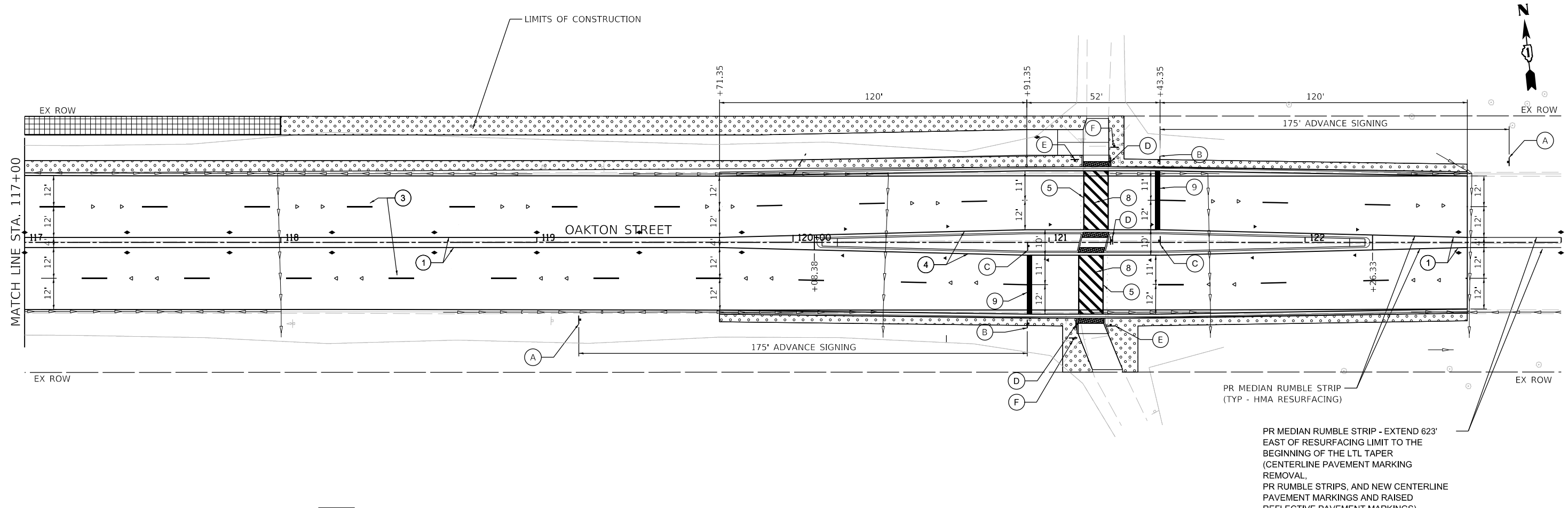

PR MEDIAN RUMBLE STRIP (TYP - HMA RESURFACING)

PR MEDIAN RUMBLE STRIP - EXTEND 623' EAST OF RESURFACING LIMIT TO THE BEGINNING OF THE LTL TAPER (CENTERLINE PAVEMENT MARKING REMOVAL, PR RUMBLE STRIPS, AND NEW CENTERLINE PAVEMENT MARKINGS AND RAISED REFLECTIVE PAVEMENT MARKINGS)

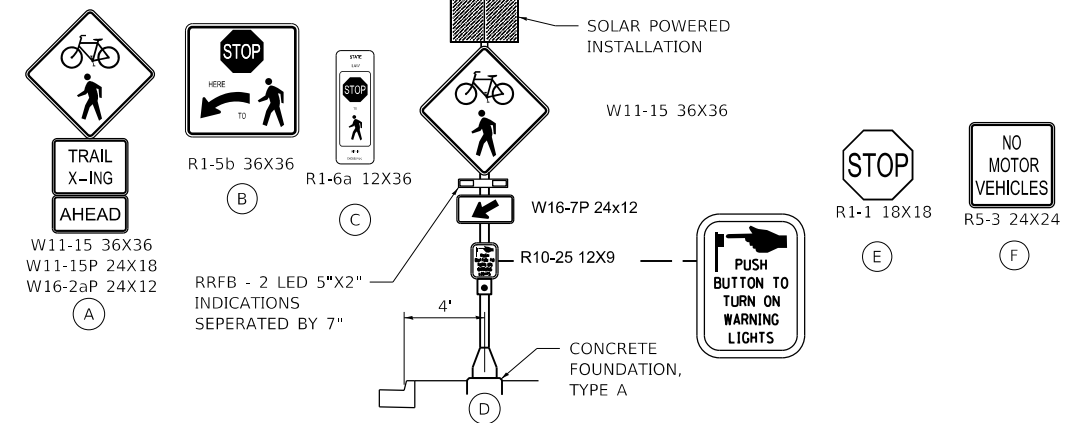

LEGEND

① THERMOPLASTIC LINE 4" (YELLOW, DOUBLE SOLID 11" C-C)	⑫ MOD URETHANE LINE 24" (WHITE, STOP BAR)
② THERMOPLASTIC LINE 4" (WHITE, SOLID EDGE LINE)	⑬ MOD URETHANE LINE 4" (YELLOW, DOUBLE SOLID 11" C-C)
③ THERMOPLASTIC LINE 4" (LANE LINE - 10' DASH 30' SKIP)	⑭ MOD URETHANE LINE 12" (YELLOW LINE, DIAGONAL)
④ THERMOPLASTIC LINE 4" (YELLOW, SOLID EDGE LINE)	⑮ MOD URETHANE LINE 6" (WHITE, SOLID LINE)
⑤ THERMOPLASTIC LINE 6" (WHITE, SOLID LINE)	⑯ MOD URETHANE LINE 6" (WHITE LANE LINE - 2' DASH 6' SKIP)
⑥ THERMOPLASTIC LINE 6" (WHITE LANE LINE - 2' DASH 6' SKIP)	⑰ PREFORMED PLASTIC (LANE LINE - 10' DASH 30' SKIP)
⑦ THERMOPLASTIC LINE 12" (YELLOW LINE, DIAGONAL)	◀ RAISED REFLECTIVE PAVEMENT MARKER - ONE-WAY CRYSTAL (W/O)
⑧ THERMOPLASTIC LINE 12" (WHITE, CROSSWALK LINE)	◀ RAISED REFLECTIVE PAVEMENT MARKER - ONE-WAY AMBER
⑨ THERMOPLASTIC LINE 24" (WHITE, STOP BAR)	◀ RAISED REFLECTIVE PAVEMENT MARKER - TWO-WAY AMBER
⑩ THERMOPLASTIC LETTERS AND SYMBOLS	▨ SEEDING CLASS 2A (SALT TOLERANT ROADSIDE MIXTURE) EROSION CONTROL BLANKET (SPECIAL)
⑪ MOD URETHANE LETTERS AND SYMBOLS	▨ SEEDING CLASS 3 (NORTHERN IL SLOPE MIXTURE) HEAVY DUTY EROSION CONTROL BLANKET, SPECIAL

- NOTES:**
- ALL PAVEMENT MARKING SHALL BE THERMOPLASTIC
 - LINE 12" (WHITE, CROSSWALK LINE) 45° SHALL BE SPACED 24" APART
 - RRFB IN MEDIAN SHALL HAVE W11-15 AND W16-7P SIGNS AND LED INDICATIONS FACING BOTH DIRECTIONS OF TRAFFIC

LEGEND

◊ INLET PROTECTION (PAID FOR AS PERIMETER EROSION BARRIER)	▨ TEMPORARY EROSION CONTROL BLANKET SEEDING, CLASS 7 (TEMPORARY)
○ INLET FILTER	▨ TEMPORARY HEAVY DUTY EROSION CONTROL BLANKET SEEDING, CLASS 7 (TEMPORARY)
— PERIMETER EROSION BARRIER	▨ WETLAND



REPLACE FAR BACK DETECTOR LOOPS ON THE EAST LEG OF OAKTON STREET

CODE NUMBER	DESCRIPTION	UNIT	TOTAL QUANTITY
85000200	MAINTENANCE OF EXISTING TRAFFIC SIGNAL INSTALLATION	EACH	1
88600600	DETECTOR LOOP REPLACEMENT	FOOT	80
89502376	REBUILD EXISTING HANDHOLE	EACH	1

NOTES:

1. THIS PLAN IS FOR THE SOLE PURPOSE OF DETECTOR LOOP REPLACEMENT.
2. THE CONTRACTOR MUST TAKE CARE TO AVOID LIVE TRAFFIC CABLES WHEN DIGGING.

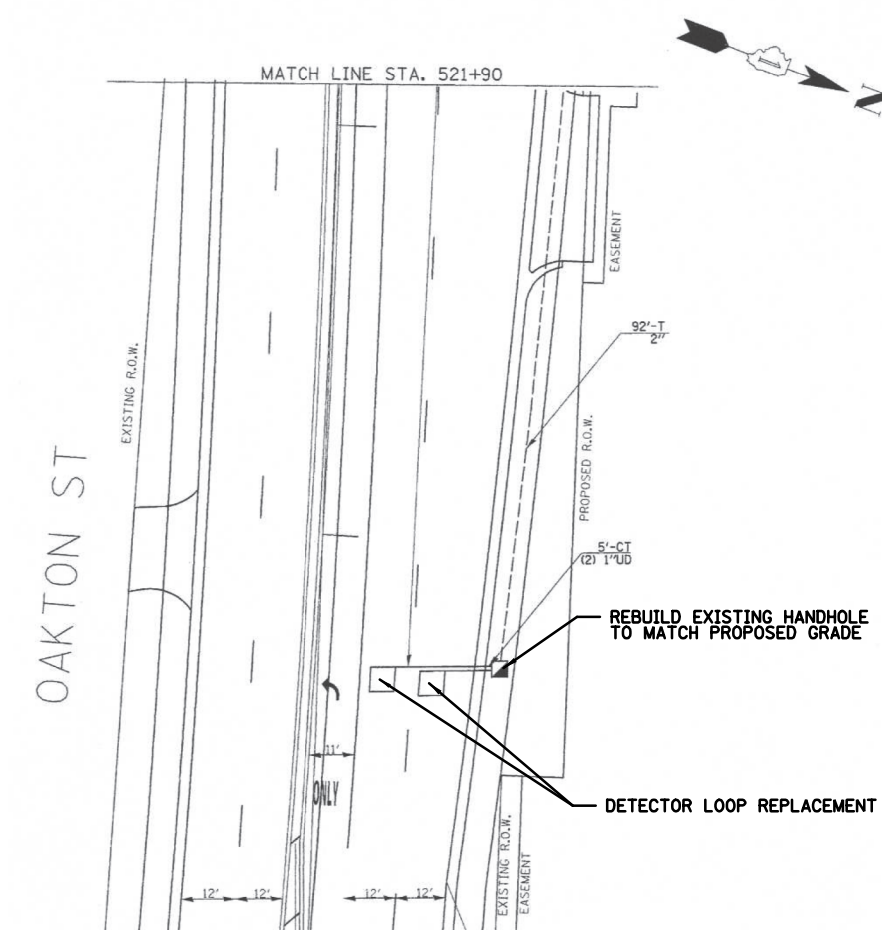
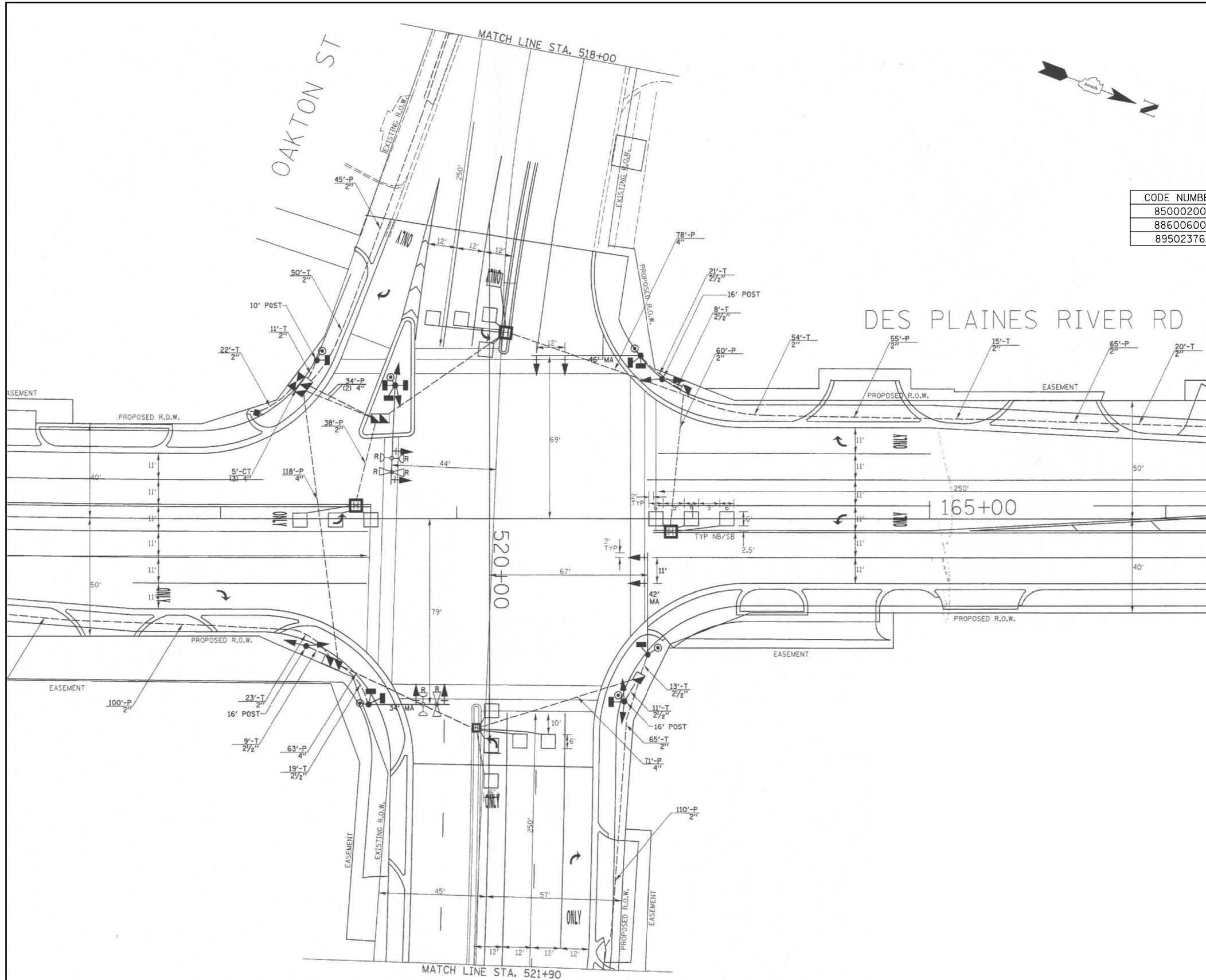

FILE NAME =	USER NAME = mthomas	DESIGNED -	REVISED -
N:\DESPLAINES\190138.00003\Civil\ITS_OAKTON\19138-03.01.SHT		DRAWN -	REVISED -
Default	PLOT DATE = 11/16/2022	CHECKED -	REVISED -
		DATE -	REVISED -

**STATE OF ILLINOIS
DEPARTMENT OF TRANSPORTATION**

**OAKTON STREET SIDEPATH
DETECTOR LOOP REPLACEMENT PLAN**

SCALE: SHEET OF SHEETS STA. TO STA.

F.A. RTE.	SECTION	COUNTY	TOTAL SHEETS	SHEET NO.
	20-00224-00-BT	COOK	89	37
CONTRACT NO. 61J19				
ILLINOIS FED. AID PROJECT				

Benchmark: OSBM 20-1 Square cut on southwest corner of conc. wall on south side of Oakton St. Bridge over the Des Plaines River. Elev. 639.57.

*From original design plans

Existing Structure: Structure 016-2601 was constructed in 1995 and replaced structure 016-0554 as part of project ACBRM-ACSTPM-7003 (056). The structure consists of 3 span continuous curved rolled steel beams on pile bent abutments and wall piers on spread footings. The bridge is 205'-1 1/2" from back of abutment to back of abutment, and has spans of 60'-8", 78'-8", and 60'-8" measured along the local tangent. The out to out width of the bridge is 80'-0" measured radially. The bridge is skewed 13°-00' to the left. The sidewalk and barrier wall on the north side of the bridge are to be removed to construct a multi-use path. A single slope parapet wall with a parapet railing, bicycle railing, and a built-up path will be constructed.

No salvage.

Traffic utilizing stage construction.

Sheet Pile Wall with Concrete Cap and Bicycle Railing, Special Max. Exposed H = 3' See Civil Plans

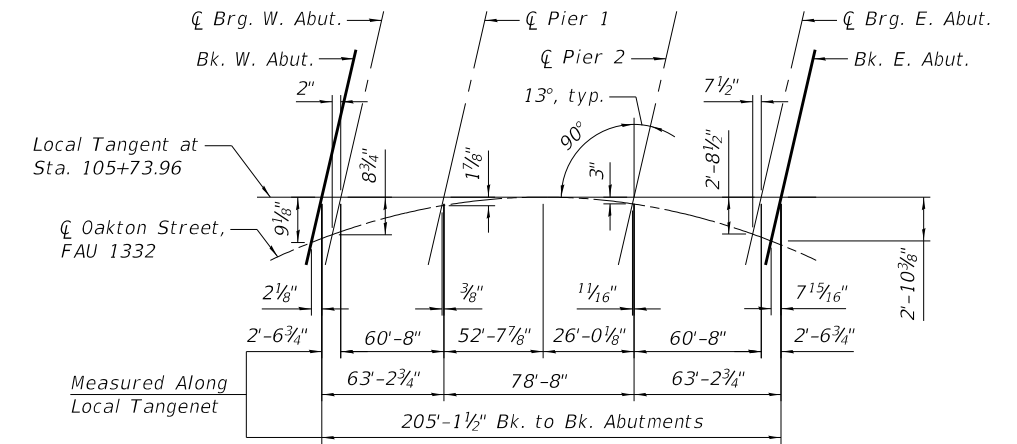

* OFFSET SKETCH

SEISMIC DATA

Seismic Performance Zone (SPZ) = 1
 Design Spectral Acceleration at 1.0 sec. (SD1) = 0.084g
 Design Spectral Acceleration at 0.2 sec. (SDS) = 0.146g
 Soil Site Class = D

DESIGN SPECIFICATIONS

Original Design:
 1989 AASHTO with 1990 Interim Specifications;
 1983 Seismic Guide Specification with 1985 and 1988 Interims; 1980 Guide Specifications for Horizontally Curved Bridges with Interims thru 1990
 Proposed Work:
 2002 AASHTO Standard Specifications, 17th Edition

DESIGN STRESSES

FIELD UNITS
 f'c = 3,500 psi - Existing
 f'c = 4,000 psi - Proposed (Superstructure)
 fy = 60,000 psi (Reinforcement) - Existing and Proposed
 fy = 50,000 psi (Structural Steel) (M270 Grade 50) - Existing
 fy = 36,000 psi (Structural Steel) (M270 Grade 36) - Existing

LOADING HS-20

Pedestrian Load = 90 psf (on multi-use path)
 Allow 25#/sq. ft. for future wearing surface.

GENERAL PLAN AND ELEVATION

OAKTON STREET OVER
 DES PLAINES RIVER
 FAU RTE. 1332
 SECTION 1300B-89
 COOK COUNTY
 STATION 105+73.96
 STRUCTURE NO. 016-2601

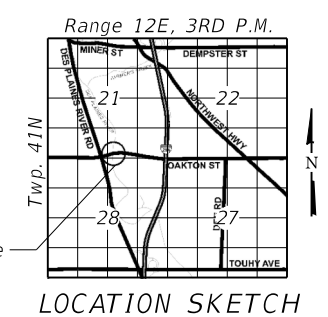
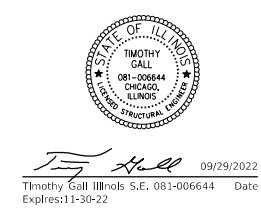
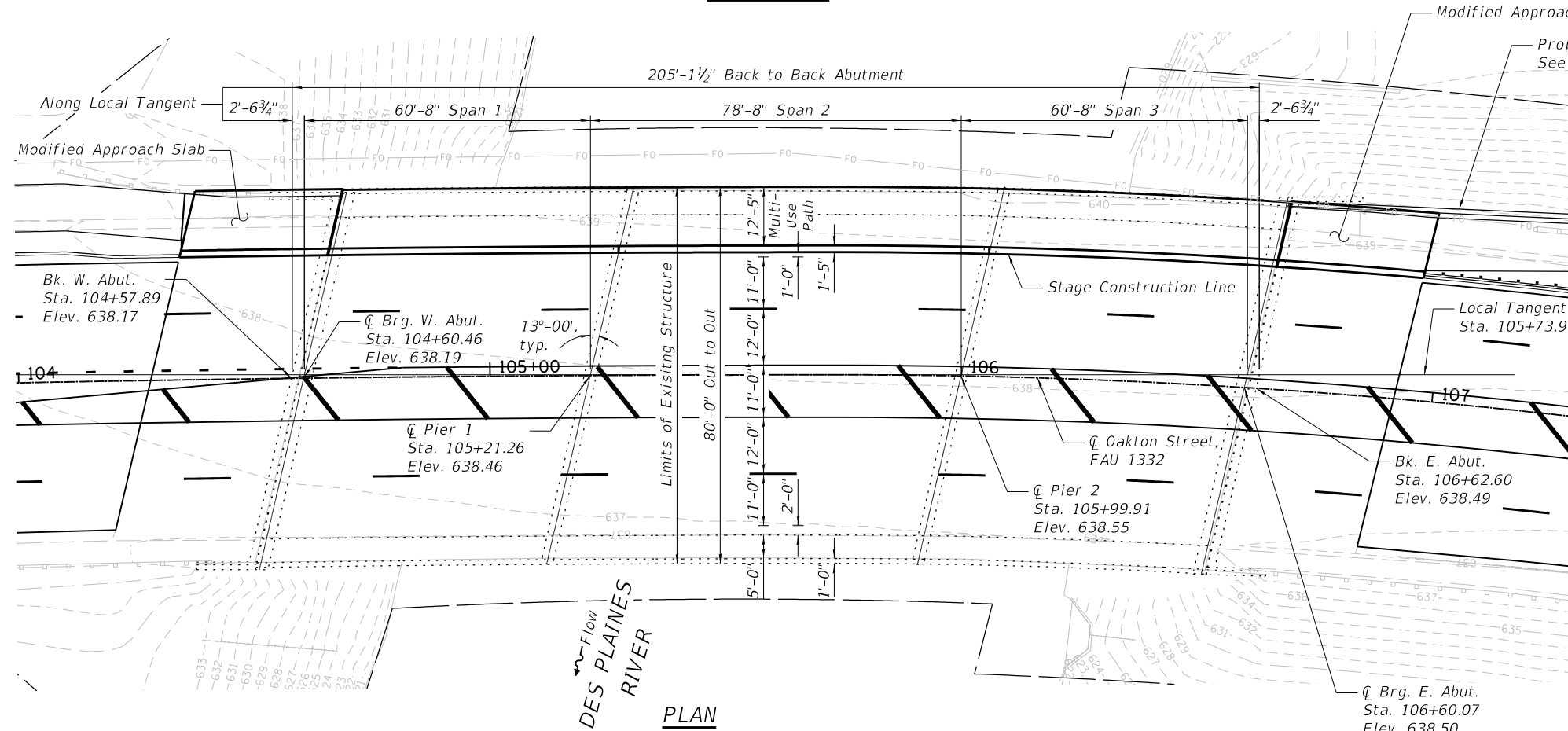
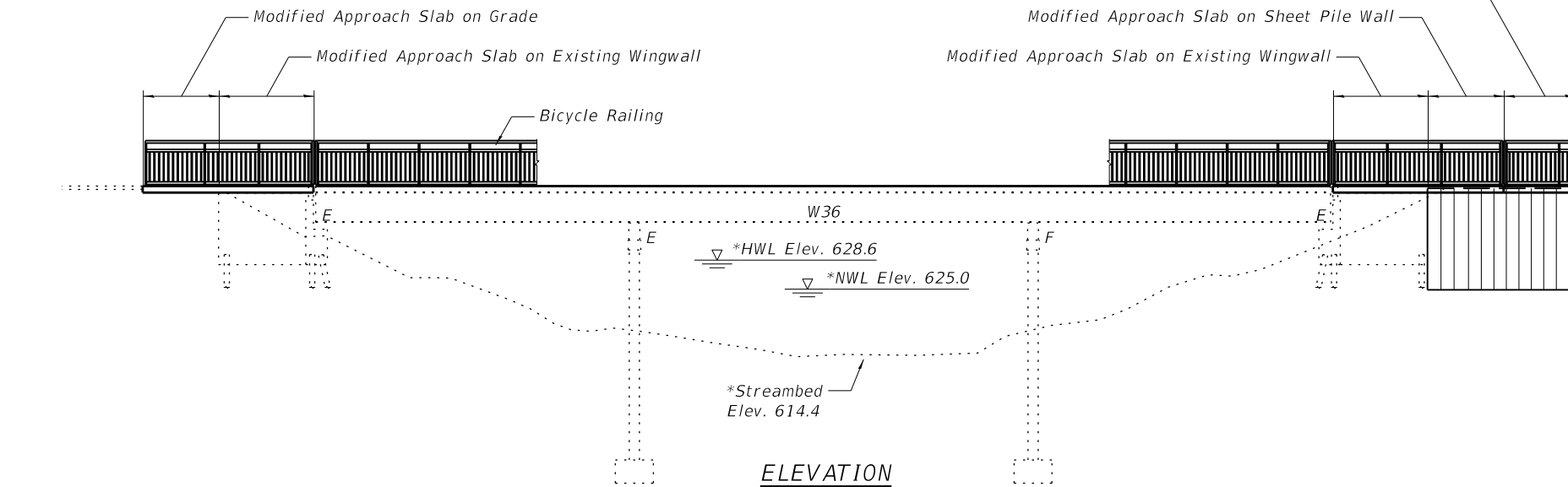

11/16/2022 1:40:46 PM
 FILE NAME: P:\Projects\210200\210200-DESIGN\01_Discipline\Civil\Working\Sheets\0162601_001.GPJ



USER NAME = dreilly	DESIGNED - CMS	REVISD -
PLOT SCALE = 3/32" = 1' / in.	DRAWN - CMS	REVISD -
PLOT DATE = 11/16/2022	CHECKED - TCG	REVISD -
	DATE - 11/2/2022	REVISD -

STATE OF ILLINOIS
 DEPARTMENT OF TRANSPORTATION

OAKTON STREET OVER THE DES PLAINES RIVER
 GENERAL PLAN AND ELEVATION
 SCALE: N.T.S. SHEET 1 OF 10 SHEETS STA. TO STA.

F.A.U. RTE.	SECTION	COUNTY	TOTAL SHEETS	SHEET NO.
	20-00224-00-BT	COOK	89	39
CONTRACT NO. 61J19			ILLINOIS FED. AID PROJECT	

GENERAL NOTES

1. Reinforcement bars designated (E) shall be epoxy coated.
2. Prior to pouring the new concrete deck, all heavy or loose rust, loose mill scale, and other loose or potentially detrimental foreign material shall be removed from the surfaces in contact with concrete. Tightly adhered paint may remain unless otherwise noted. Removal shall be accomplished by methods that will not damage the steel and the cost will be included in the pay item covering removal of the existing concrete.
3. Plan dimensions and details relative to existing plans are subject to nominal construction variations. The Contractor shall field verify existing dimensions and details affecting new construction and make necessary approved adjustments prior to construction or ordering of materials. Such variations shall not be cause for additional compensation for a change in scope of the work, however, the Contractor will be paid for the quantity actually furnished at the unit price bid for the work.

INDEX OF SHEETS

- S-1 General Plan and Elevation
- S-2 General Data
- S-3 Stage Construction Details
- S-4 Temporary Concrete Barrier Details
- S-5 Superstructure Details
- S-6 Approach Slabs
- S-7 Approach Slab Details
- S-8 Railing Details
- S-9 Preformed Joint Strip Seal Details 1
- S-10 Preformed Joint Strip Seal Details 2

TOTAL BILL OF MATERIAL

ITEM	UNIT	SUPER	SUB	TOTAL
Welded Wire Reinforcement	Sq Yd	269		269
Concrete Removal	Cu Yd	48.2		48.2
Bridge Rail Removal	Foot	199		199
Concrete Superstructure	Cu Yd	88.0		88.0
Protective Coat	Sq Yd	587		587
Concrete Superstructure (Approach Slab)	Cu Yd	45.2		45.2
Reinforcement Bars, Epoxy Coated	Pound	19,680		19,680
Preformed Joint Strip Seal	Foot	25		25
Approach Slab Removal	Sq Yd	88		88
Bridge Deck Scarification 1 1/2"	Sq Yd	304		304
Bicycle Railing	Foot	264		264
Parapet Railing	Foot	264		264

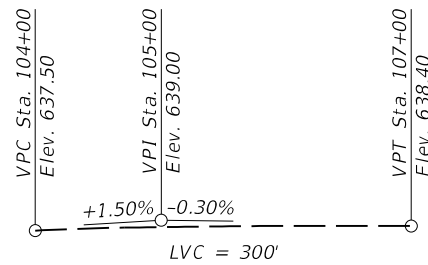

* **PROFILE GRADE**
(Oakton Street)

* **CURVE DATA**

P.I. Sta. = 104+44.13
 $\Delta = 1^\circ-41'-14.4''$
 $D = 0^\circ-38'-59''$
 $R = 8,819.63'$
 $T = 129.88'$
 $L = 259.73'$
 $E = 0.96'$
 $S.E. = 0.032 \text{ '}'$
 $S.E. \text{ Transition Limits} = \text{Sta. } 102+64 \text{ to Sta. } 104+39$
 $\text{Full } S.E. = \text{Sta. } 104+39 \text{ to Sta. } 105+73.96$
 $P.C. \text{ Sta.} = 103+14.25$
 $P.T. \text{ Sta.} = 105+73.96$

* **CURVE DATA**

P.I. Sta. = 108+26.39
 $\Delta = 20^\circ-52'-11''$
 $D = 4^\circ-10'-50''$
 $R = 1,370.55'$
 $T = 252.41'$
 $L = 499.22'$
 $E = 23.05'$
 $S.E. = 0.032 \text{ '}'$
 $\text{Full } S.E. = \text{Sta. } 105+73.96 \text{ to Sta. } 110+50$
 $S.E. \text{ Transition Limits} = \text{Sta. } 110+50 \text{ to Sta. } 111+90.20$
 $P.C. \text{ Sta.} = 105+73.96$
 $P.T. \text{ Sta.} = 110+73.20$

*From original design plans

11/22/2022 8:17:41 AM
 FILE NAME: P:\Projects\210000\21953_C_DESIGN\01_Discipline\01_Working\Sheets\0162601_002-struccted.dgn



USER NAME = dreilly	DESIGNED - CMS	REVISED -
DRAWN - CMS	REVISIONS -	
PLOT SCALE = 32.0000' / in.	CHECKED - TCG	REVISED -
PLOT DATE = 11/22/2022	DATE - 11/2/2022	REVISED -

**STATE OF ILLINOIS
 DEPARTMENT OF TRANSPORTATION**

**OAKTON STREET OVER THE DES PLAINES RIVER
 GENERAL DATA**

SCALE: N.T.S. SHEET 2 OF 10 SHEETS STA. TO STA.

F.A.U. RTE.	SECTION	COUNTY	TOTAL SHEETS	SHEET NO.
	20-00224-00-BT	COOK	89	40
			CONTRACT NO. 61J19	
ILLINOIS FED. AID PROJECT				

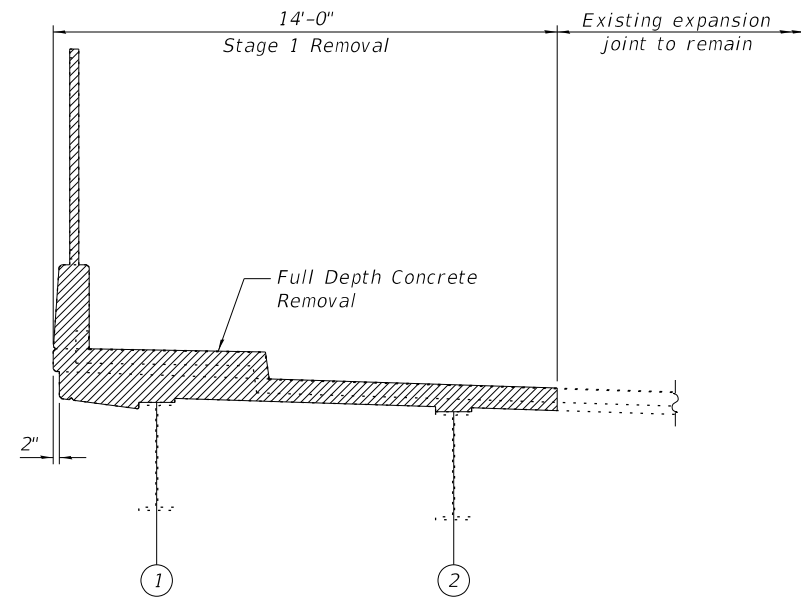

STAGE 1 REMOVAL AT EXPANSION JOINT

Note:
Existing reinforcement shall be cleaned and incorporated into the new construction. Extreme care shall be taken so as not to damage the existing reinforcement during concrete removal. Any reinforcement bars that are damaged during concrete removal shall be replaced with an approved bar splicer or anchorage system. Cost included with Concrete Removal.

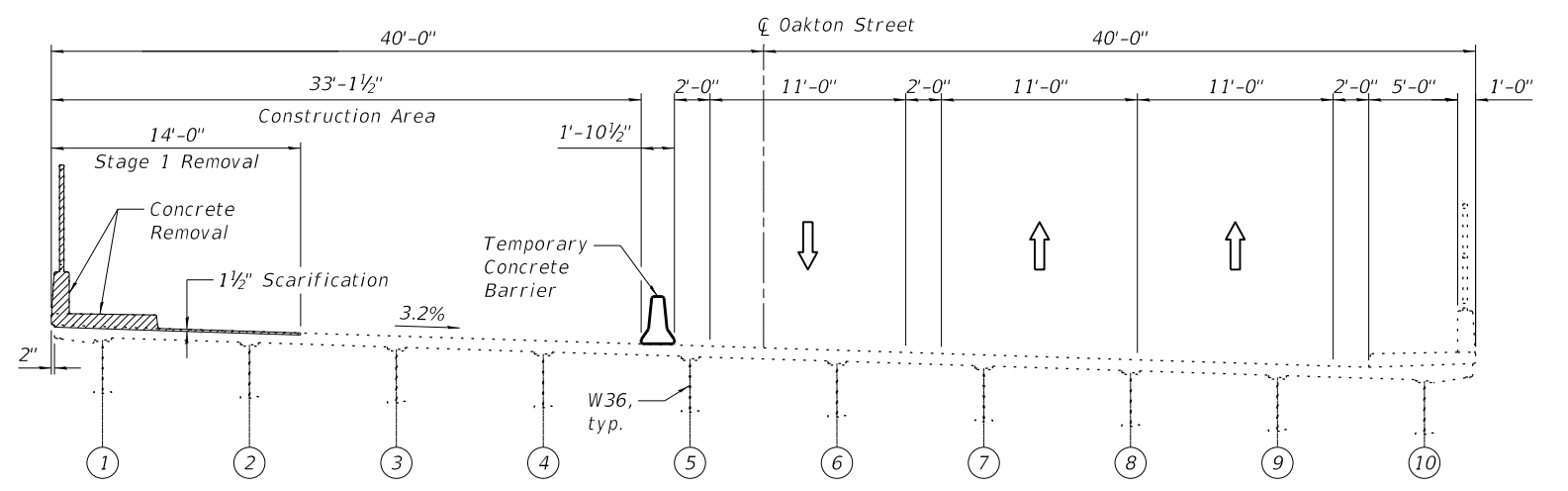

STAGE 1 REMOVAL

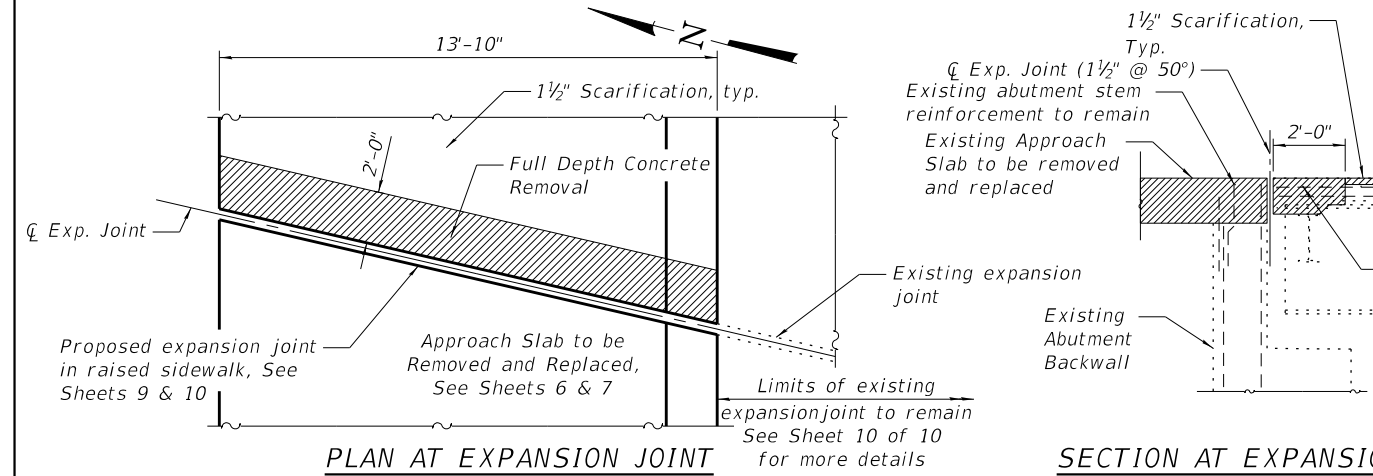

PLAN AT EXPANSION JOINT

SECTION AT EXPANSION JOINT

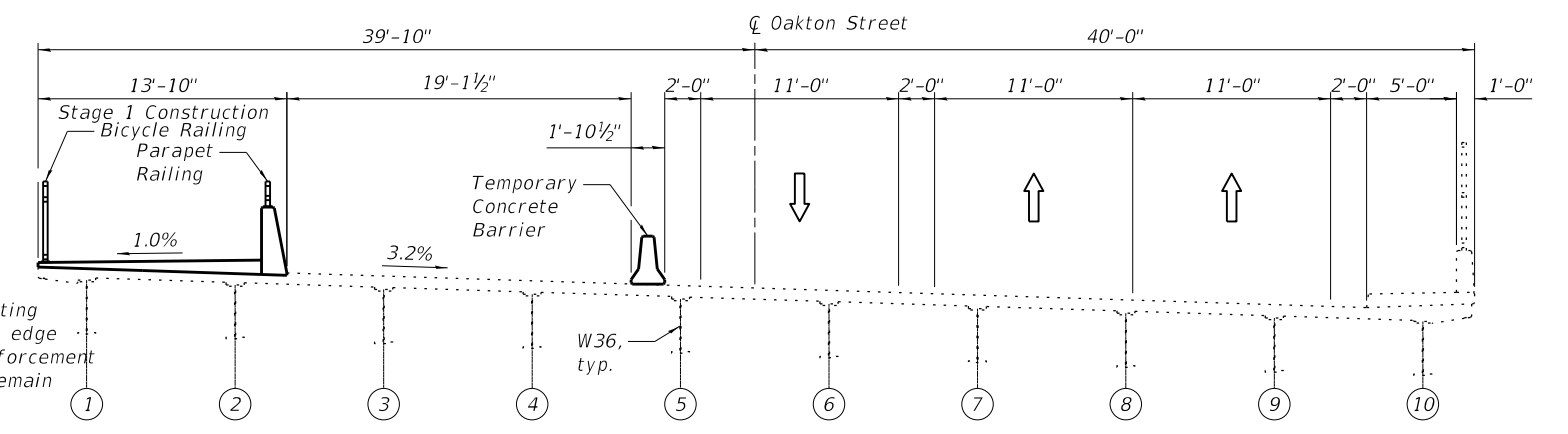

STAGE 1 CONSTRUCTION

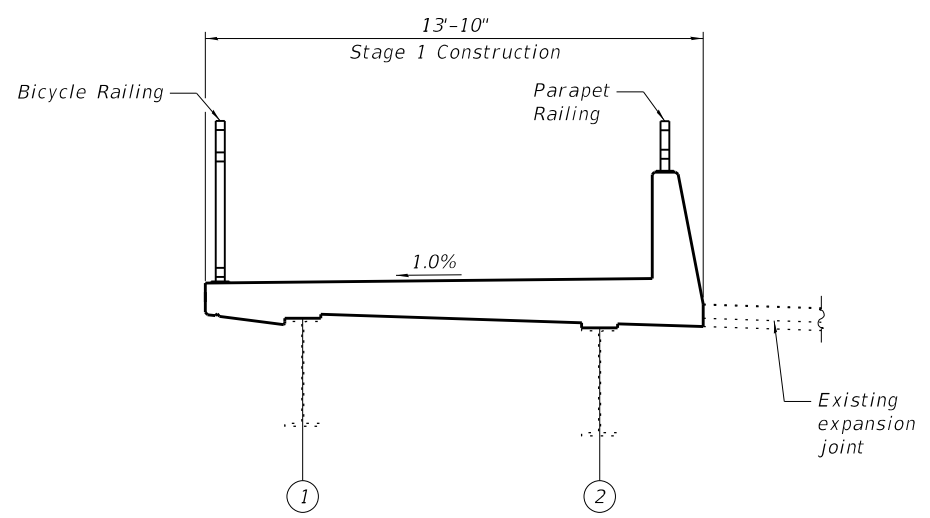

STAGE 1 CONSTRUCTION AT EXPANSION JOINT

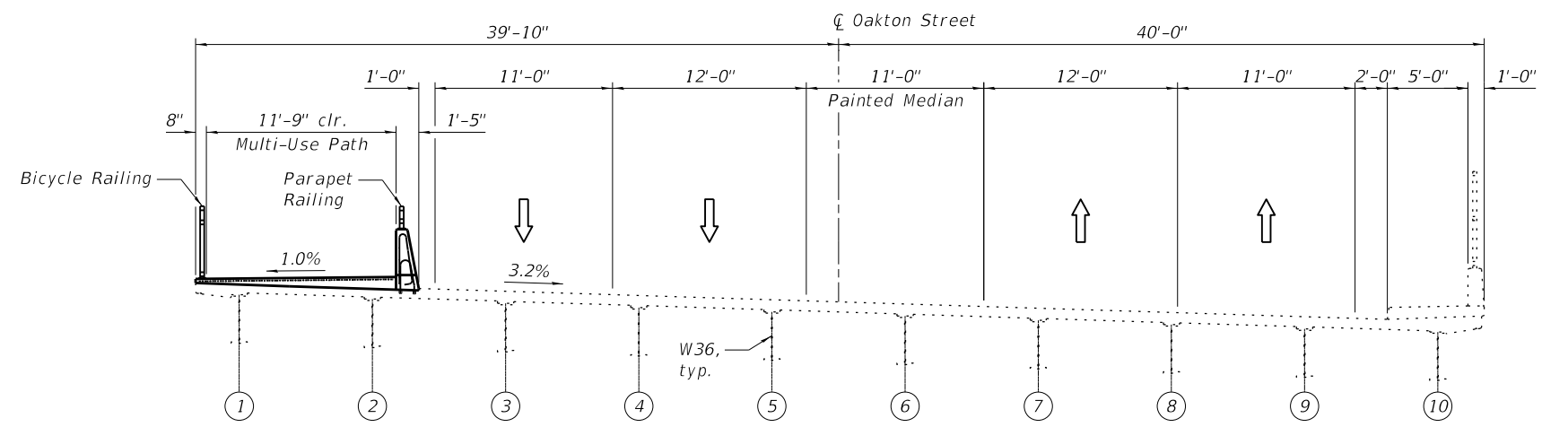

FINAL TYPICAL SECTION

Note:
Refer to Special Provision for Bridge Deck Scarification 1 1/2".

11/28/2022 1:19:46 PM
FILE NAME = P:\Projects\210000\21953_C_DESIGN\01_Discipline\Civil\Working\Sheets\0162601_003-sta.mxd



USER NAME = dreilly	DESIGNED - CMS	REVISED -
DRAWN - CMS	REVISOR -	
PLOT SCALE = 1/8" = 1' / in.	CHECKED - TCG	REVISOR -
PLOT DATE = 11/28/2022	DATE - 11/2/2022	REVISOR -

**STATE OF ILLINOIS
DEPARTMENT OF TRANSPORTATION**

**OAKTON STREET OVER THE DES PLAINES RIVER
STAGE CONSTRUCTION DETAILS**

SCALE: N.T.S. SHEET 3 OF 10 SHEETS STA. TO STA.

F.A.U. RTE.	SECTION	COUNTY	TOTAL SHEETS	SHEET NO.
	20-00224-00-BT	COOK	89	41
CONTRACT NO. 61J19			ILLINOIS FED. AID PROJECT	

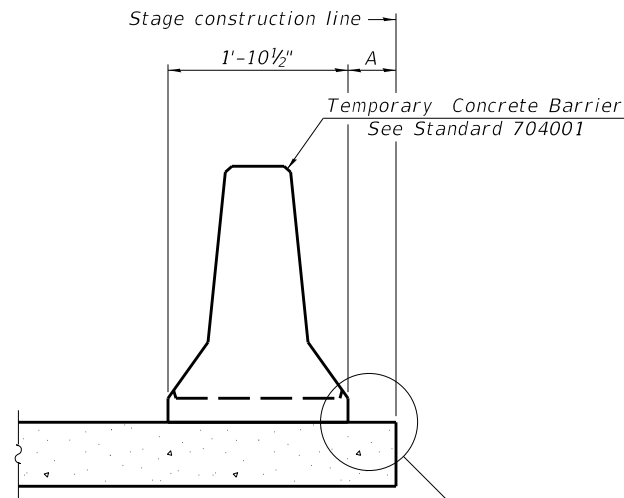

When "A" is 3'-1" or less, the temporary concrete barrier shall be restrained to the new slab according to Detail I, II or III. No restraint is required when "A" is greater than 3'-1".

NEW SLAB OR NEW DECK BEAM

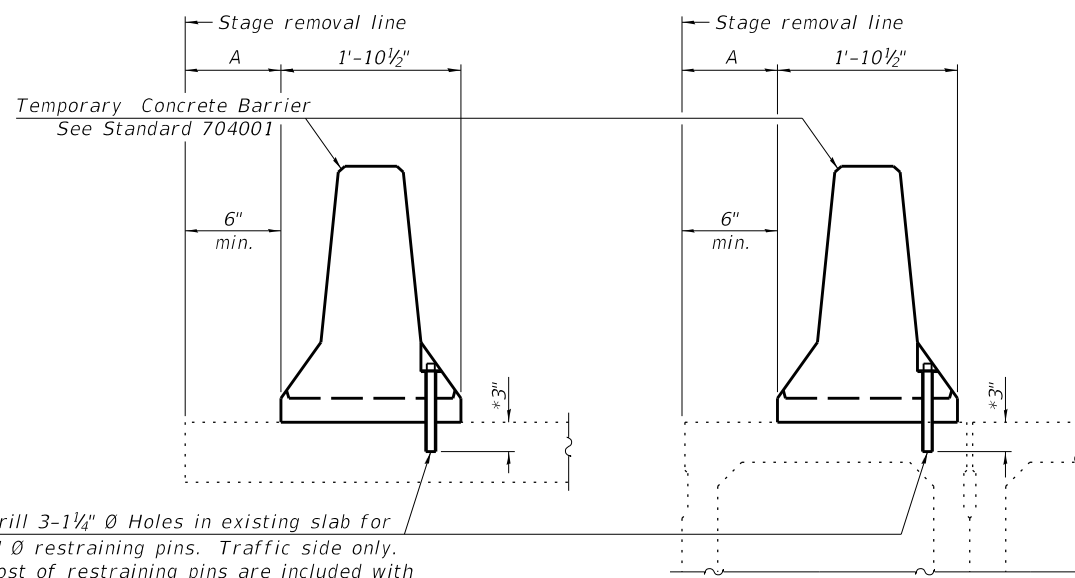

EXISTING SLAB

EXISTING DECK BEAM

SECTIONS THRU SLAB OR DECK BEAM

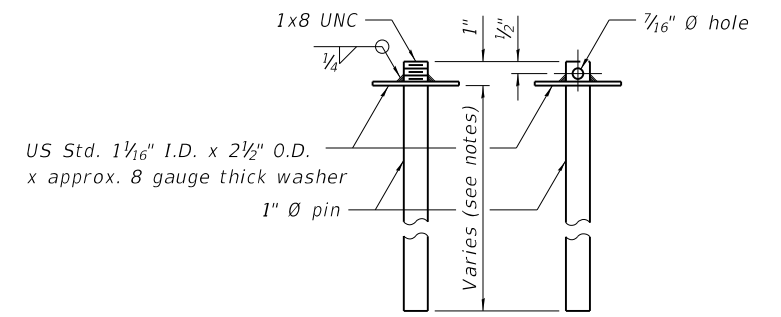

RESTRAINING PIN

* When hot-mix asphalt wearing surface is present, embedment shall be 3" plus the wearing surface depth.

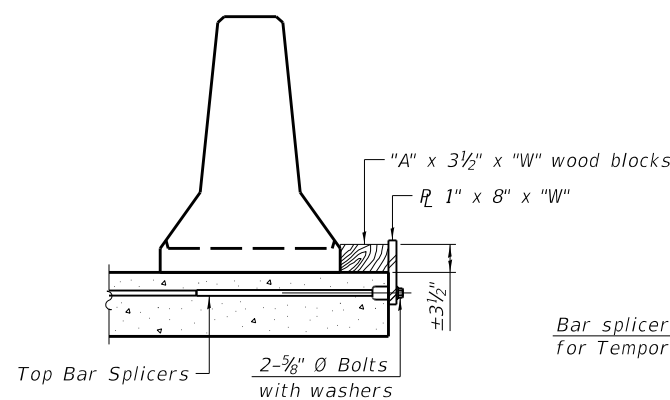

DETAIL I

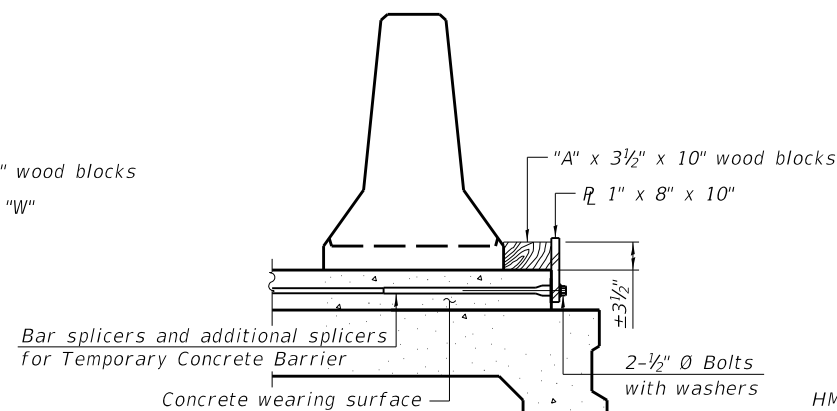

DETAIL II

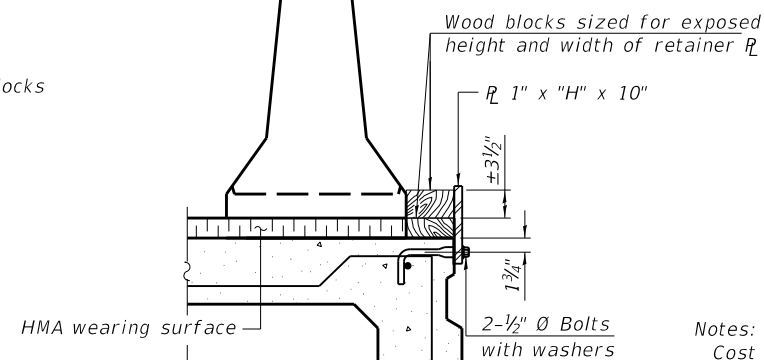

DETAIL III

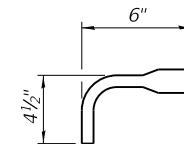

BAR SPLICER FOR #4 BAR - DETAIL III

Notes:

- Cost of retainer assembly is included with Temporary Concrete Barrier.
- A retainer assembly shall be located at the approximate \bar{c} of each temporary concrete barrier.
- The retainer plate shall not be removed until the concrete on the adjacent stage is ready to be poured. For Detail III applications the retainer plate shall not be removed until just prior to placing the adjacent beam.
- When the 'A' dimension is less than 1 1/2', the wood block shall be omitted and the barrier shall be placed in direct contact with the steel retainer plate.
- For deck beam applications the minimum required 'A' distance is 6" to accommodate the shear key clamping device.

- Detail I - Installation for a new bridge deck or bridge slab.
- Detail II - Installation for a new deck beam with an initial concrete wearing surface. Additional bar splicers shall be provided at 6'-0" centers and paired with the bar splicers of the concrete wearing surface reinforcement to accommodate the installation of the retainer assemblies. The cost of the additional bar splicers is included with the concrete wearing surface.
- Detail III - Installation for a new deck beam with no initial wearing surface or with an initial hot-mix asphalt (HMA) wearing surface present. The deck beam directly beneath the temporary concrete barrier shall be fabricated with bar splicer inserts in the side of the beam, as detailed, to accommodate the installation of the retainer assemblies. A pair of bar splicers, 6" apart, shall be placed at 6'-0" centers along the length of the beam. The cost of the bar splicers is included with the deck beam.

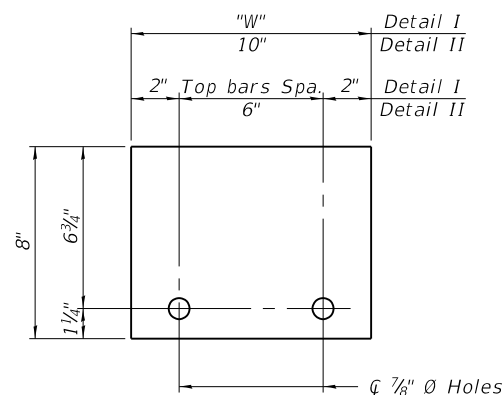

STEEL RETAINER R 1" x 8" x "W"
(Detail I and II)

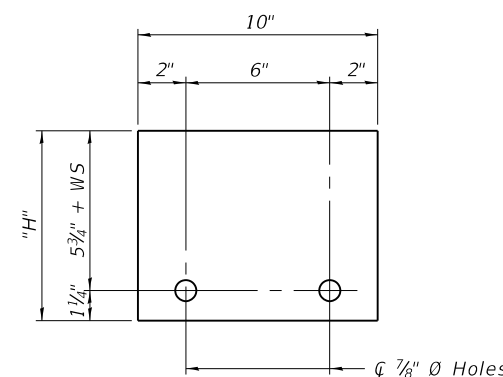

STEEL RETAINER R 1" x "H" x 10"
(Detail III)

RAILING CRITERIA

NCHRP 350 Test Level	3
Railing Weight (plf)	440

R-27 10-12-2021

11/16/2022 1:40:52 PM
FILE NAME: P:\Projects\210200\210200\210200\DESIGN\01_Design\01_Dispatch\01_Civil\Working\Sheets\0162601_004-TCB.dgn



USER NAME = dreilly	DESIGNED - CMS	REVISED -
PLOT SCALE = 2:0 "1" = 1"	DRAWN - CMS	REVISED -
PLOT DATE = 11/16/2022	CHECKED - TCG	REVISED -
	DATE - 11/2/2022	REVISED -

STATE OF ILLINOIS
DEPARTMENT OF TRANSPORTATION

OAKTON STREET OVER THE DES PLAINES RIVER
TEMPORARY CONCRETE BARRIER DETAILS

SCALE: N.T.S. SHEET 4 OF 10 SHEETS STA. TO STA.

F.A.U. RTE.	SECTION	COUNTY	TOTAL SHEETS	SHEET NO.
	20-00224-00-BT	COOK	89	42
CONTRACT NO. 61J19			ILLINOIS FED. AID PROJECT	

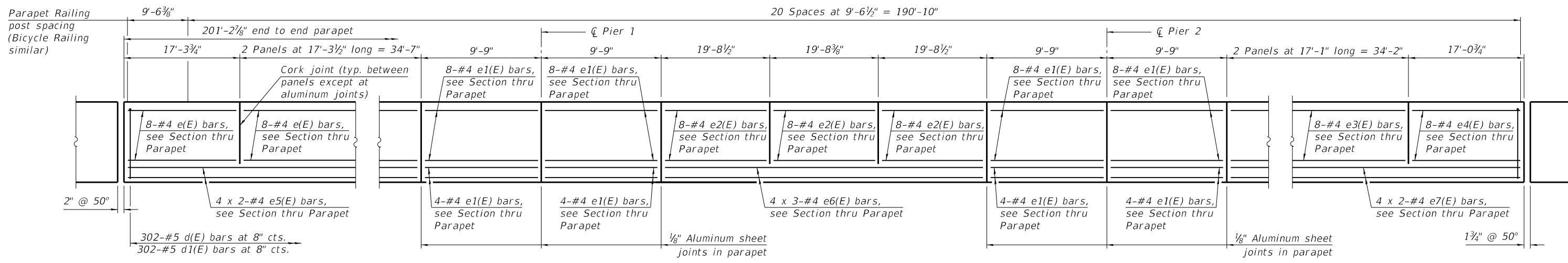

INSIDE ELEVATION OF PARAPET

MINIMUM BAR LAP
#4 bar = 2'-5"

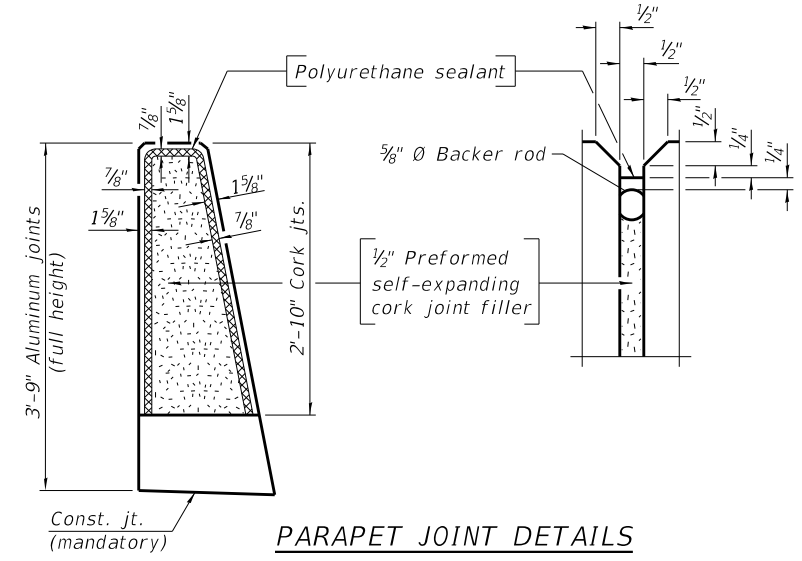

Notes:
The 1/8" Aluminum sheet shall be ASTM B 209 alloy 3003-H14 and coated to minimize reaction with wet concrete. Cost included with Concrete Superstructure.
The Polyurethane Sealant shall be according to Article 1050.04 of the Std. Spec. and the color shall be gray.

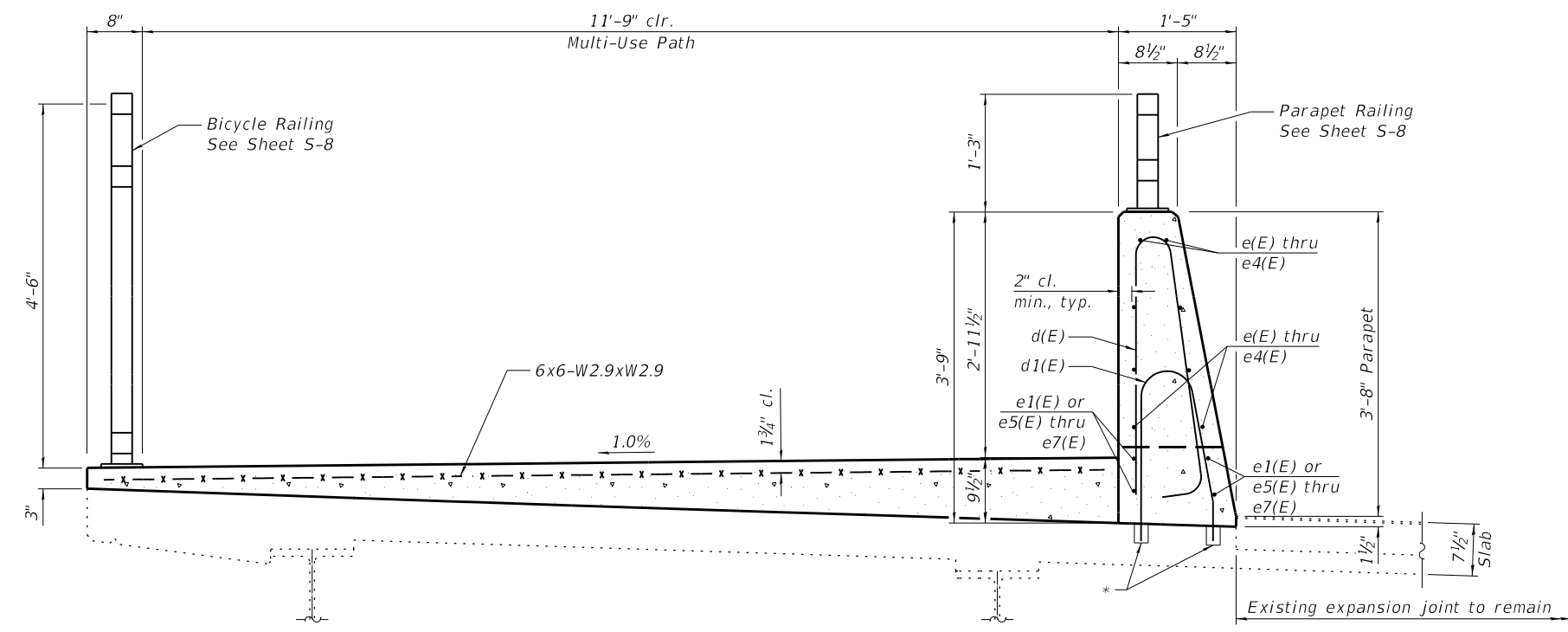

SECTION THRU MULTI-USE PATH AND PARAPET

Notes:
See Sheets S-9 and S-10 for Preformed Joint Strip Seal.
See Sheet S-10 for Section Thru Multi-Use Path at joint.

* Core and set #5 d1(E) bar according to Article 509.06 of the Standard Specifications. Cored holes shall be roughened or scored per manufacturer's recommendations. Maximum depth of hole shall not exceed 6".

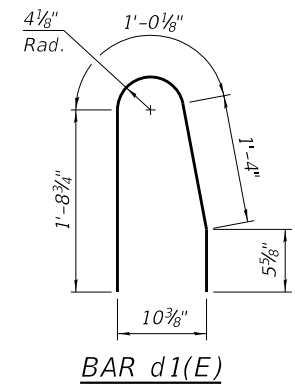
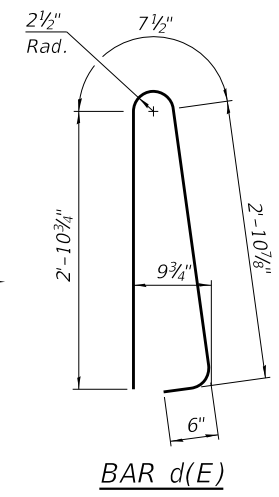

SUPERSTRUCTURE BILL OF MATERIAL

Bar	No.	Size	Length	Shape	
d(E)	302	#5	7'-0"	U	
d1(E)	302	#5	4'-7"	U	
e(E)	24	#4	16'-11"	—	
e1(E)	48	#4	9'-5"	—	
e2(E)	24	#4	19'-4"	—	
e3(E)	16	#4	16'-9"	—	
e4(E)	8	#4	16'-8"	—	
e5(E)	8	#4	27'-0"	—	
e6(E)	12	#4	21'-3"	—	
e7(E)	8	#4	26'-8"	—	
Reinforcement Bars, Epoxy Coated				Lbs.	5,260
Welded Wire Reinforcement				Sq. Yds.	269
Concrete Superstructure				Cu. Yds.	78.5

Bars indicated thus 1 x 2-#4 etc. indicates 1 line of bars with 2 lengths per line.

1/16/2022 1:40:54 PM
FILE NAME = P:\Projects\210000\210000\DESIGN\01_Discipline\01_Civil\Working\Sheets\0162601_005-super.dgn



USER NAME = dreilly	DESIGNED - CMS	REVISED -
PLOT SCALE = 8:0 "1" / in.	DRAWN - CMS	REVISED -
PLOT DATE = 11/16/2022	CHECKED - TCG	REVISED -
	DATE - 11/2/2022	REVISED -

STATE OF ILLINOIS
DEPARTMENT OF TRANSPORTATION

OAKTON STREET OVER THE DES PLAINES RIVER
SUPERSTRUCTURE DETAILS

SCALE: N.T.S. SHEET 5 OF 10 SHEETS STA. TO STA.

F.A.U. RTE.	SECTION	COUNTY	TOTAL SHEETS	SHEET NO.
	20-00224-00-BT	COOK	89	43
CONTRACT NO. 61J19			ILLINOIS FED. AID PROJECT	

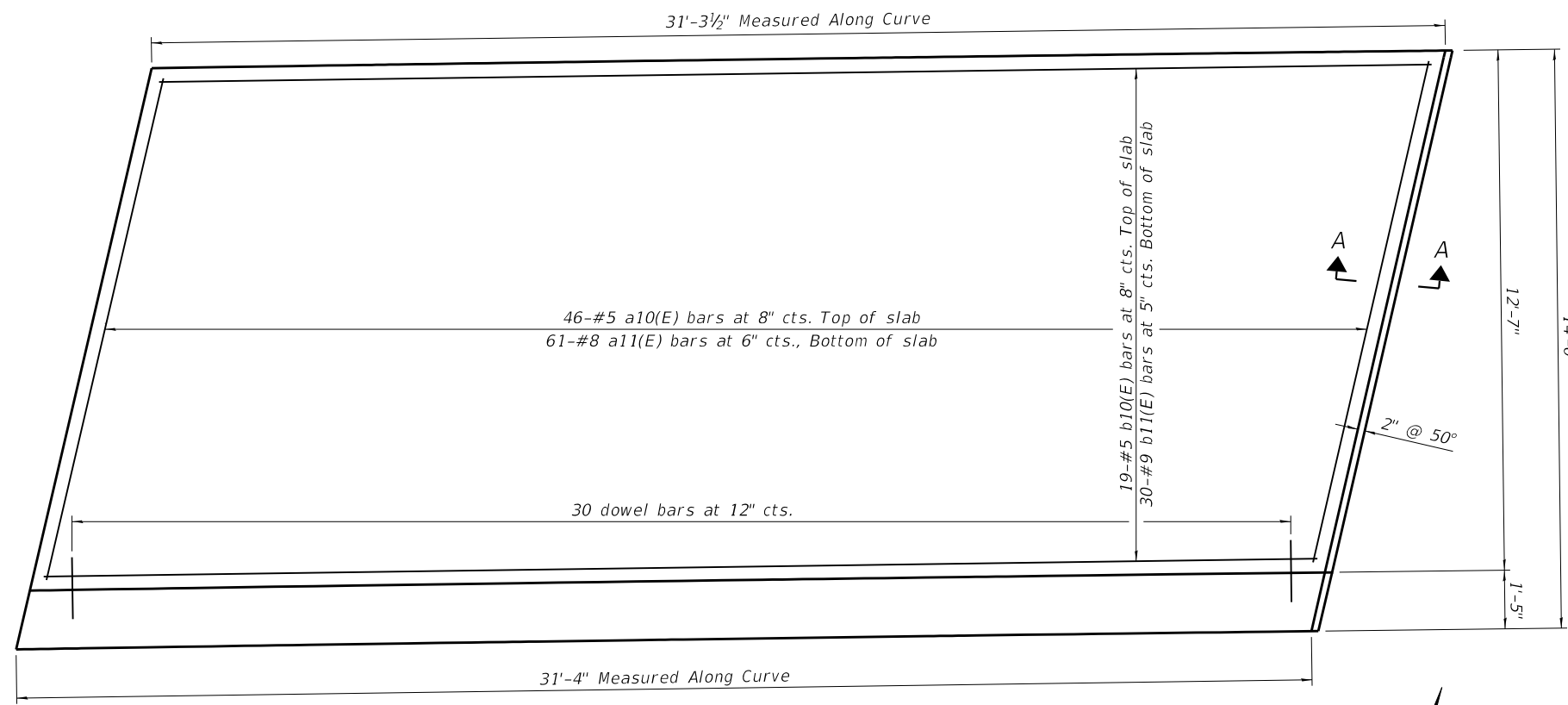

WEST APPROACH PLAN

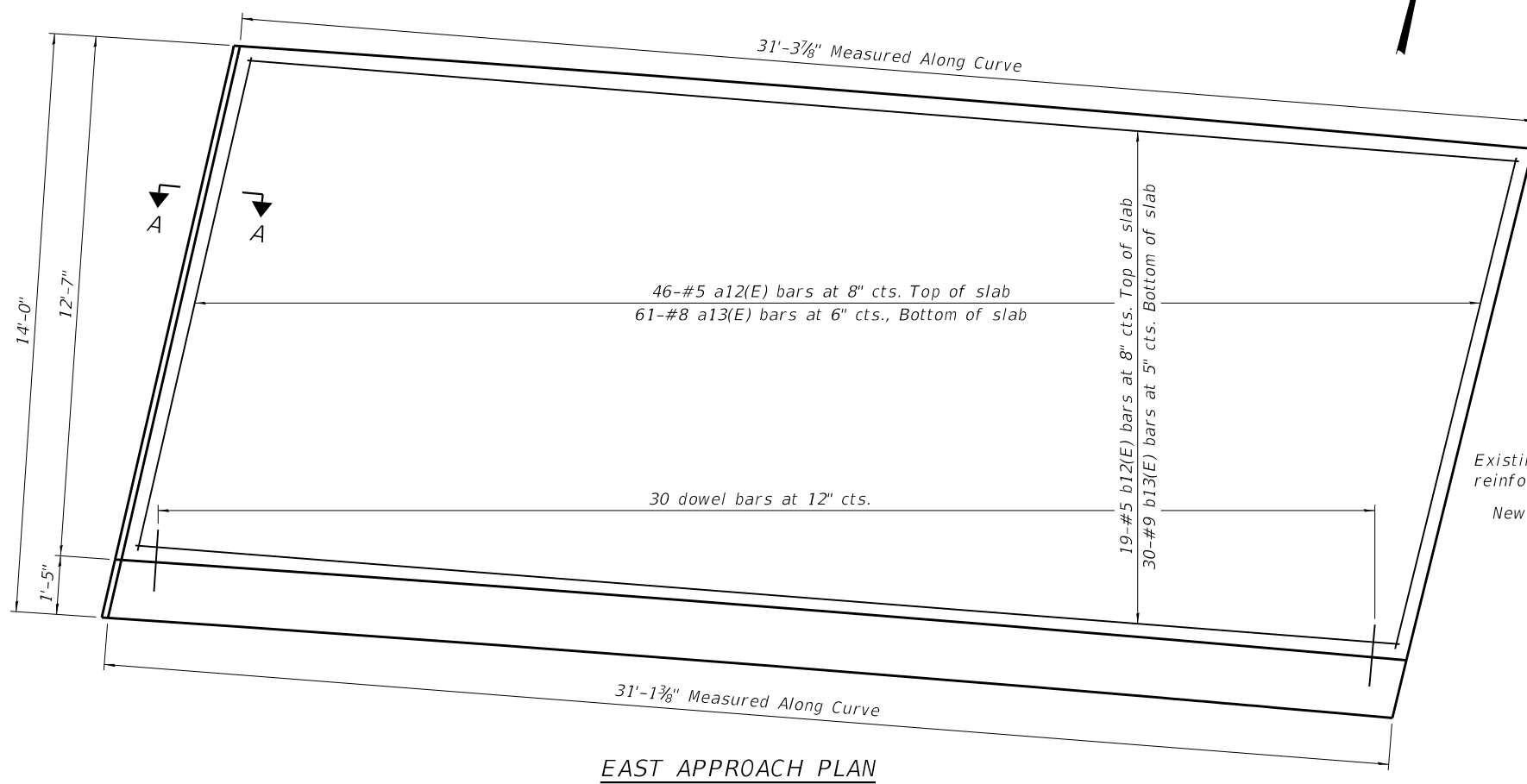

EAST APPROACH PLAN

Estimated removal elevation (verify in field)
 ±638.24 (front of wingwall)
 ±638.13 (back of wingwall)

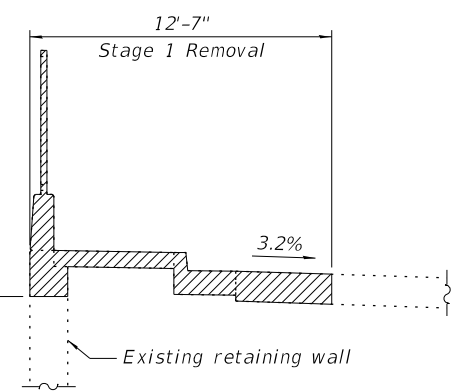

WEST APPROACH - STAGE 1 REMOVAL

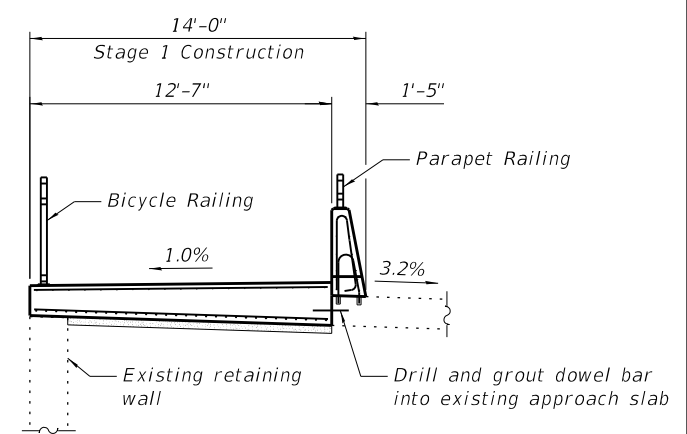

WEST APPROACH - STAGE 1 CONSTRUCTION

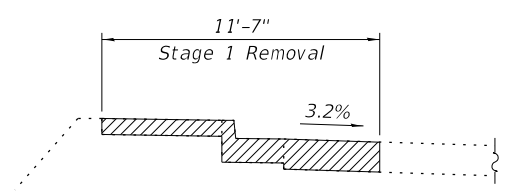

EAST APPROACH - STAGE 1 REMOVAL

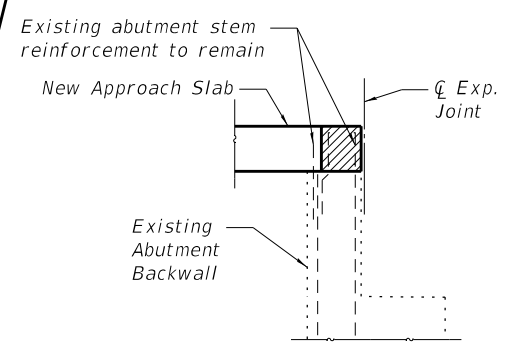

SECTION A-A

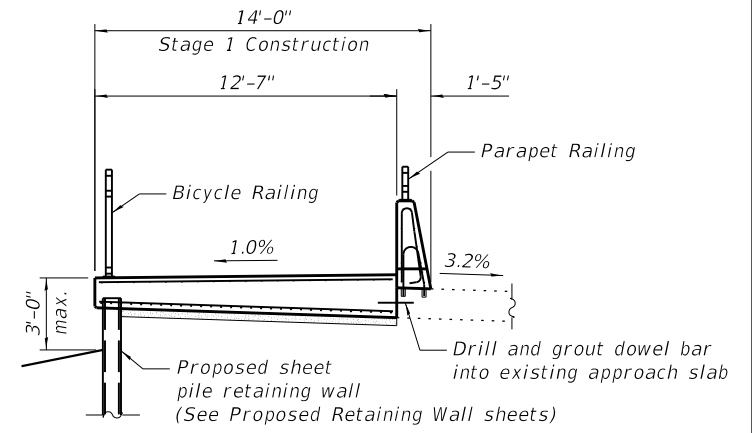

EAST APPROACH - STAGE 1 CONSTRUCTION

1/16/2022 1:40:55 PM
 FILE NAME = P:\Projects\21000\21953_C_DESIGN\01_Discipline\Civil\Working\Sheets\0162601_006-approach\01.dgn



USER NAME = dreilly	DESIGNED - CMS	REVISED -
PLOT SCALE = 8:0" 1' = 1/8"	DRAWN - CMS	REVISED -
PLOT DATE = 11/16/2022	CHECKED - TCG	REVISED -
	DATE - 11/2/2022	REVISED -

STATE OF ILLINOIS
 DEPARTMENT OF TRANSPORTATION

OAKTON STREET OVER THE DES PLAINES RIVER
 APPROACH SLABS

SCALE: N.T.S. SHEET 6 OF 10 SHEETS STA. TO STA.

F.A.U. RTE.	SECTION	COUNTY	TOTAL SHEETS	SHEET NO.
	20-00224-00-BT	COOK	89	44
CONTRACT NO. 61J19			ILLINOIS FED. AID PROJECT	

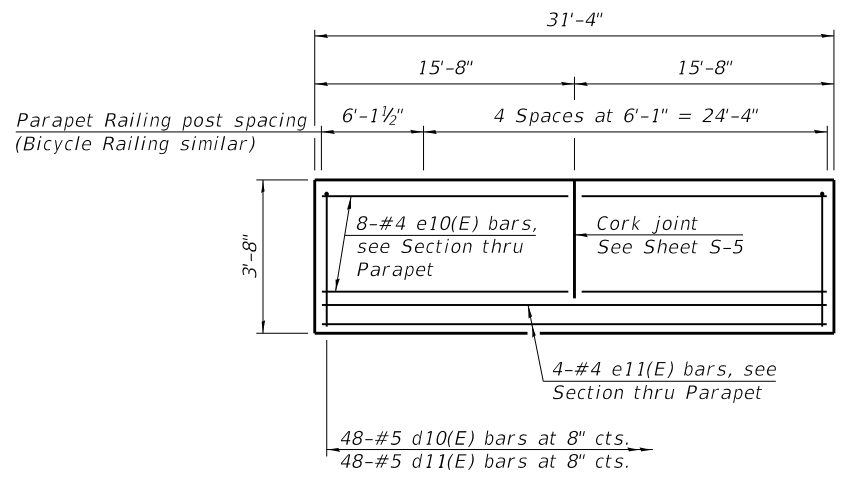

INSIDE ELEVATION OF WEST PARAPET

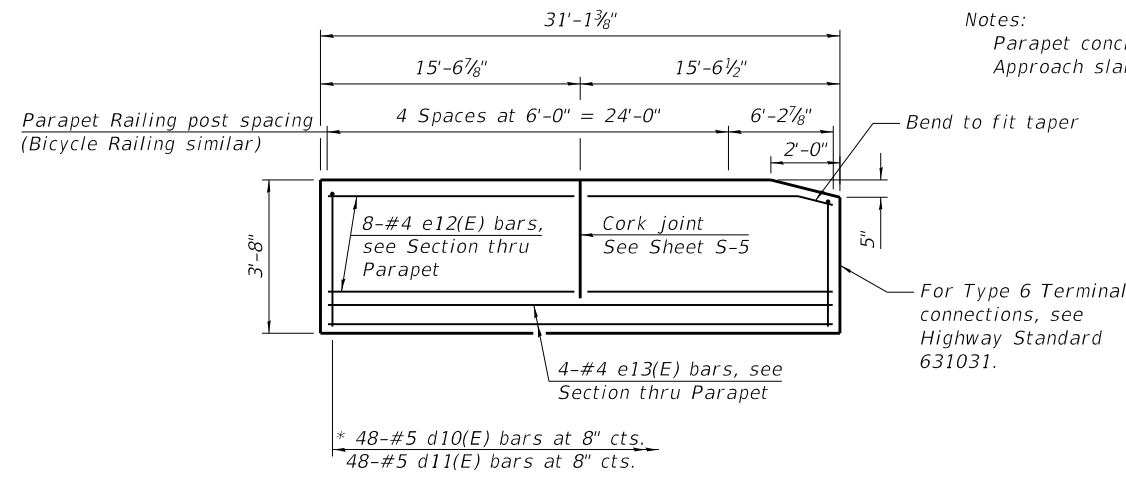

INSIDE ELEVATION OF EAST PARAPET

Notes:
Parapet concrete shall be paid for as Concrete Superstructure.
Approach slab shall be paid for as Concrete Superstructure (Approach Slab).

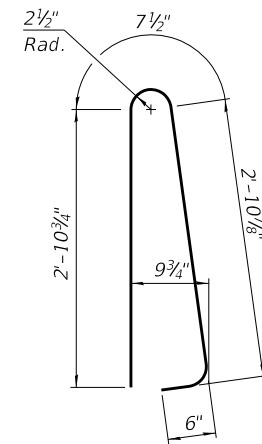

BAR d10(E)

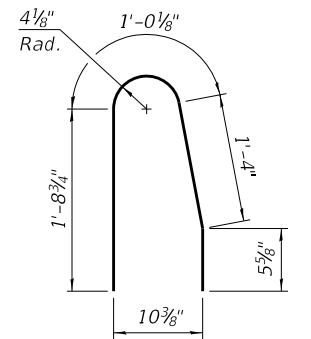

BAR d11(E)

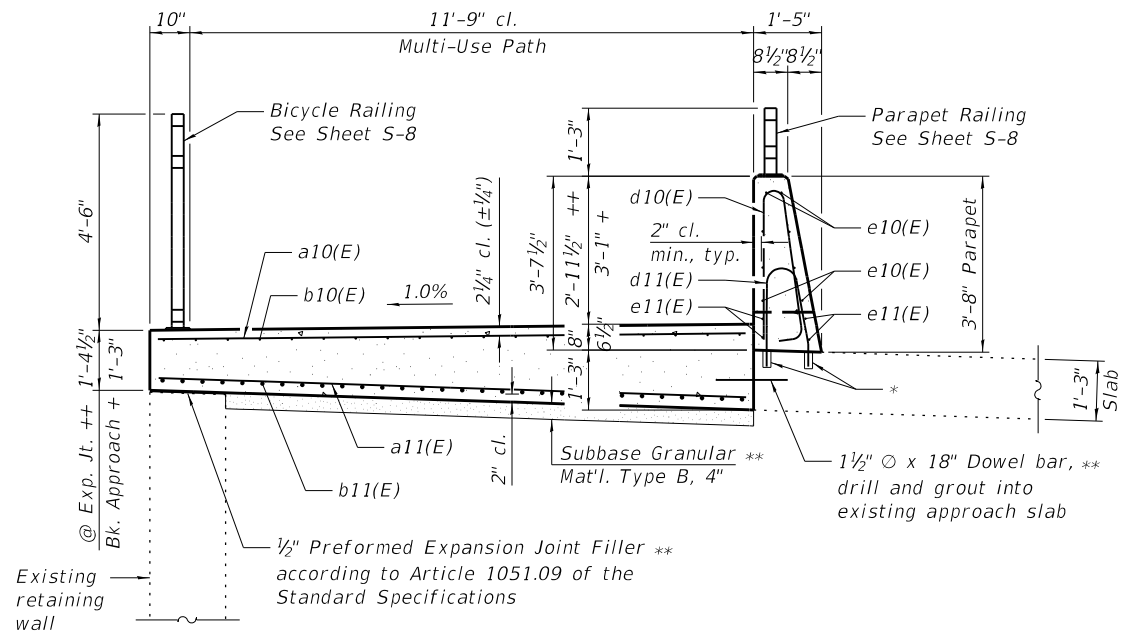

SECTION THRU WEST APPROACH MULTI-USE PATH AND PARAPET

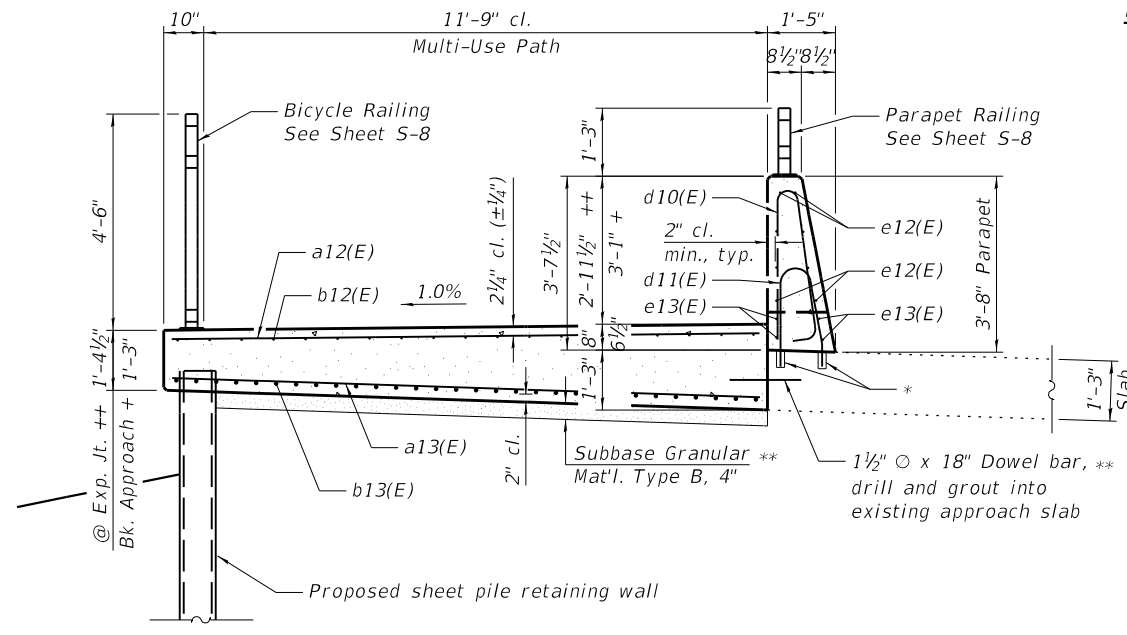

SECTION THRU EAST APPROACH MULTI-USE PATH AND PARAPET

* Core and set #5 d11(E) bar according to Article 509.06 of the Standard Specifications. Cored holes shall be roughened or scored per manufacturer's recommendations. Maximum depth of hole shall not exceed 6".

** Cost included with Concrete Superstructure (Approach Slab).

TWO APPROACHES BILL OF MATERIAL

Bar	No.	Size	Length	Shape
a10(E)	46	#5	12'-7"	—
a11(E)	61	#8	12'-7"	—
a12(E)	46	#5	12'-4"	—
a13(E)	61	#8	12'-4"	—
b10(E)	19	#5	30'-11"	—
b11(E)	30	#9	30'-11"	—
b12(E)	19	#5	30'-9"	—
b13(E)	30	#9	30'-9"	—
d10(E)	96	#5	7'-0"	U
d11(E)	96	#5	4'-7"	U
e10(E)	16	#4	15'-4"	—
e11(E)	4	#4	31'-0"	—
e12(E)	16	#4	15'-2"	—
e13(E)	4	#4	30'-9"	—
Concrete Superstructure			Cu. Yds.	8.9
Concrete Superstructure (Approach Slab)			Cu. Yds.	45.2
Reinforcement Bars, Epoxy Coated			Lbs.	14,420

1/16/2022 1:40:57 PM
FILE NAME: P:\Projects\210000\21953_C_DESIGN\01_Dispatch\01_01\Working\Sheets\0162601_007-approach02.dgn



USER NAME = dreilly	DESIGNED - CMS	REVISED -
PLOT SCALE = 8:0' 1" / in.	DRAWN - CMS	REVISED -
PLOT DATE = 11/16/2022	CHECKED - TCG	REVISED -
	DATE - 11/2/2022	REVISED -

**STATE OF ILLINOIS
DEPARTMENT OF TRANSPORTATION**

**OAKTON STREET OVER THE DES PLAINES RIVER
APPROACH SLAB DETAILS**

SCALE: N.T.S. SHEET 7 OF 10 SHEETS STA. TO STA.

F.A.U. RTE.	SECTION	COUNTY	TOTAL SHEETS	SHEET NO.
	20-00224-00-BT	COOK	89	45
CONTRACT NO. 61J19			ILLINOIS FED. AID PROJECT	

All steel rail elements shall be galvanized according to Article 509.05 of the Standard Specifications.

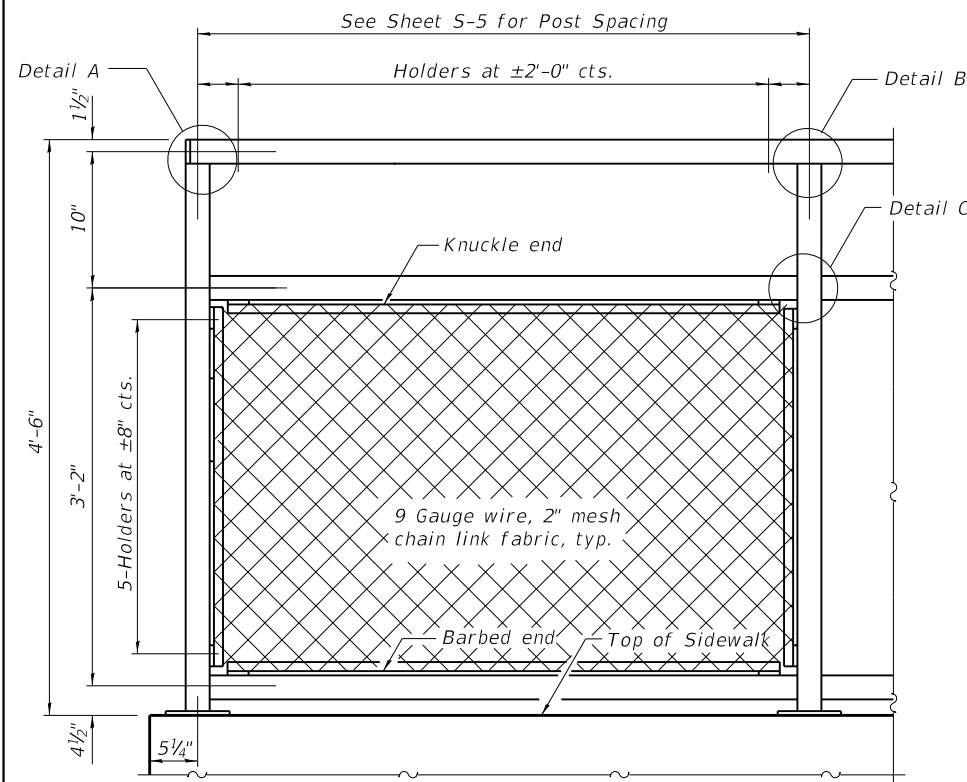

BICYCLE RAILING

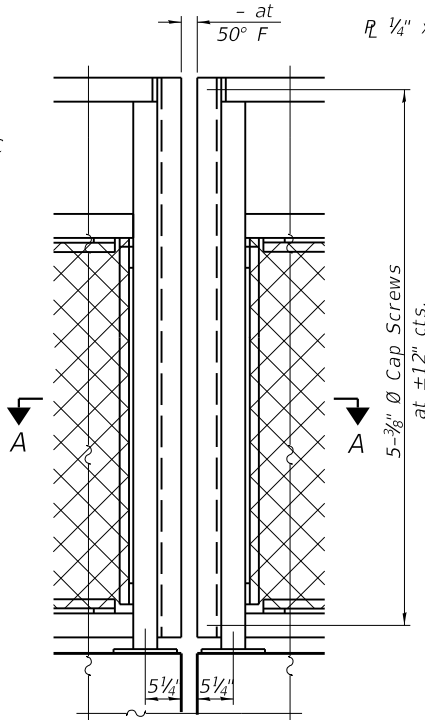

BICYCLE RAILING

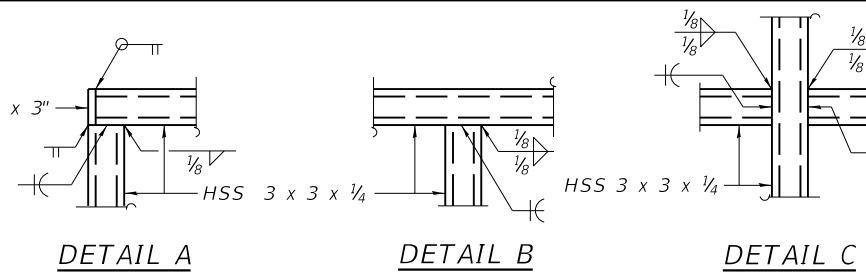

DETAIL A **DETAIL B** **DETAIL C**

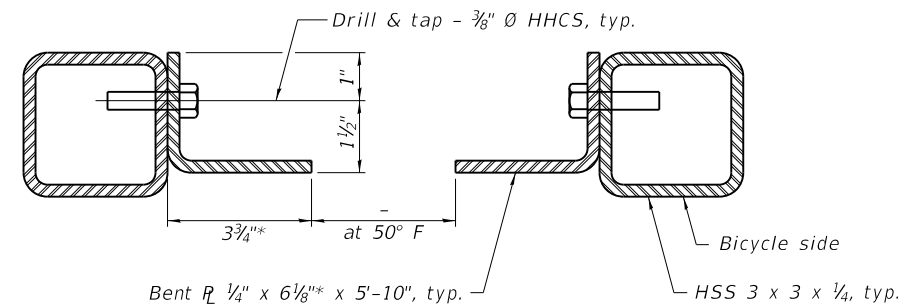

SECTION A-A
* Assume 3/8" radius. Dimensions may need to be modified for larger joints to avoid gaps greater than 6".

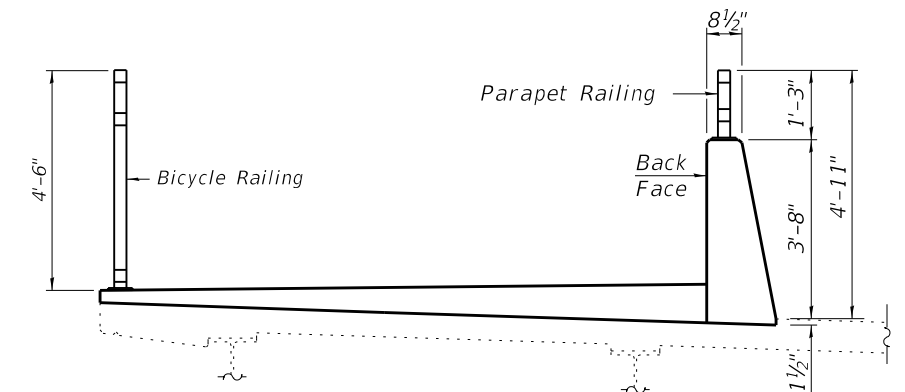

SECTION THRU DECK

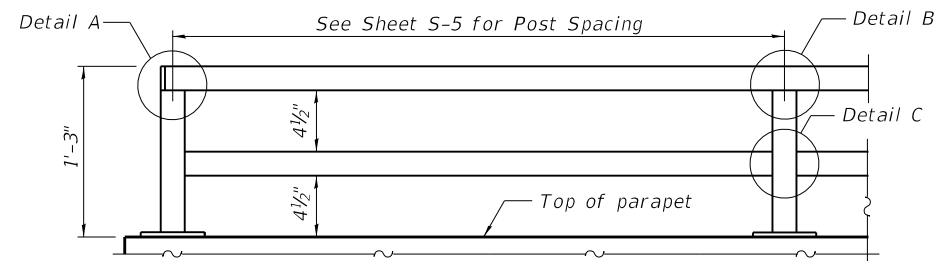

PARAPET RAILING
ELEVATION
(Inside Face of Two Element Rail)

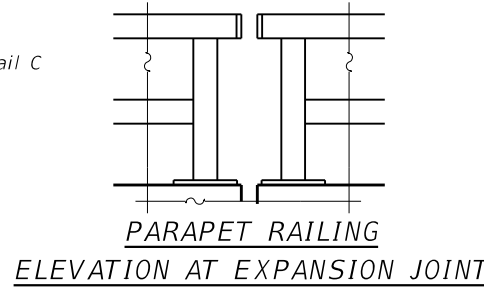

PARAPET RAILING
ELEVATION AT EXPANSION JOINT

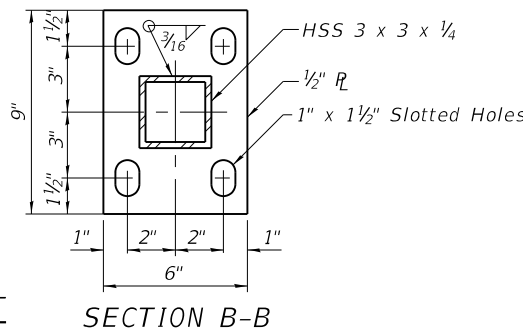

SECTION B-B

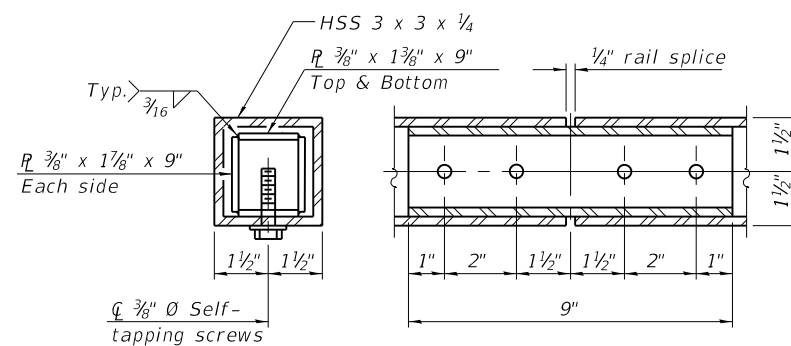

RAIL SPLICE

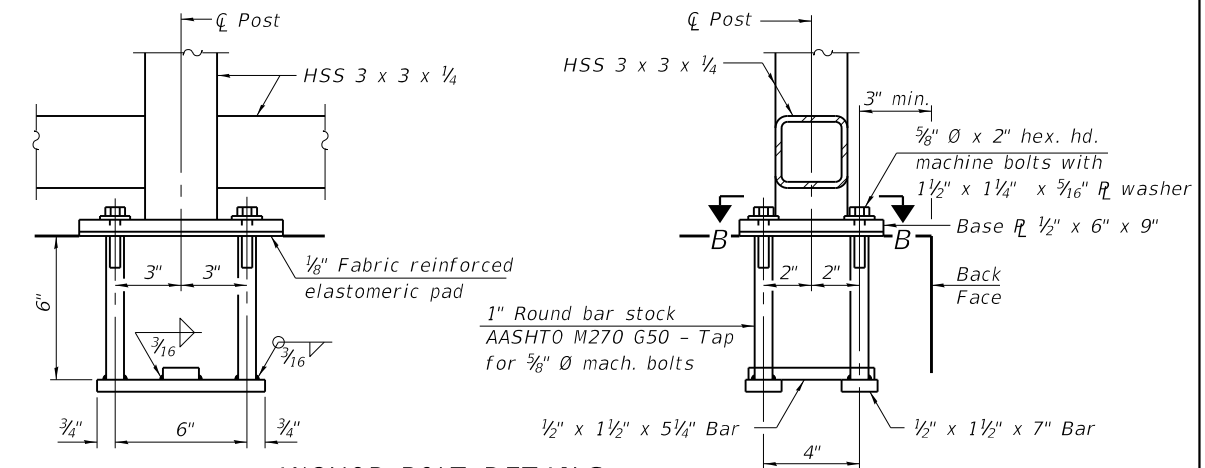

ANCHOR BOLT DETAILS

In lieu of the cast-in-place anchor device shown, the Contractor has the option of drilling and setting 5/8" Ø anchor rods according to Article 509.06 of the Standard Specifications. Embedment shall be according to the manufacturer's specifications.

BILL OF MATERIAL

Item	Unit	Quantity
Bicycle Railing	Foot	264
Parapet Railing	Foot	264

RAILING CRITERIA

NCHRP 350 Test Level	4
Railing Weight (plf)	25
Bicycle Railing Weight (plf)	50
Max Post Spacing	10'-0"

Notes:
Place reinforcement bars to miss anchor rod locations. CVN testing is not required for the HSS tubing used in the Bicycle Railing.
All HSS tubing used for the Parapet Railing shall be CVN tested according to Article 1006.34(b) of the Standard Specifications.

R-29 10-12-2021

USER NAME	DESIGNED	REVISIONS
dreilly	CMS	-
	CMS	-
	TCG	-
		-

STATE OF ILLINOIS
DEPARTMENT OF TRANSPORTATION

OAKTON STREET OVER THE DES PLAINES RIVER
RAILING DETAILS

SCALE: N.T.S. SHEET 8 OF 10 SHEETS STA. TO STA.

F.A.U. RTE.	SECTION	COUNTY	TOTAL SHEETS	SHEET NO.
	20-00224-00-BT	COOK	89	46
CONTRACT NO. 61J19				

ILLINOIS FED. AID PROJECT

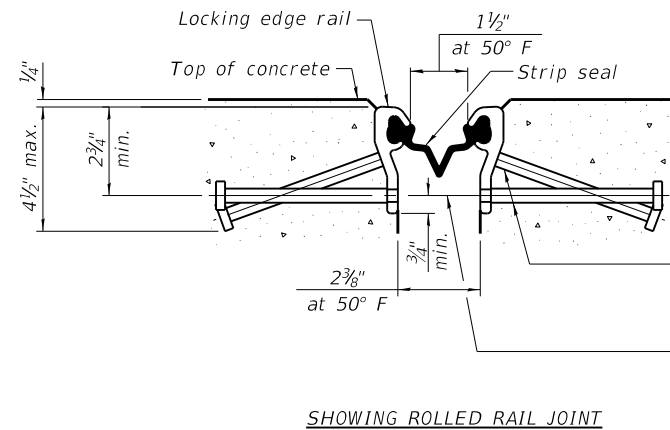

SHOWING ROLLED RAIL JOINT

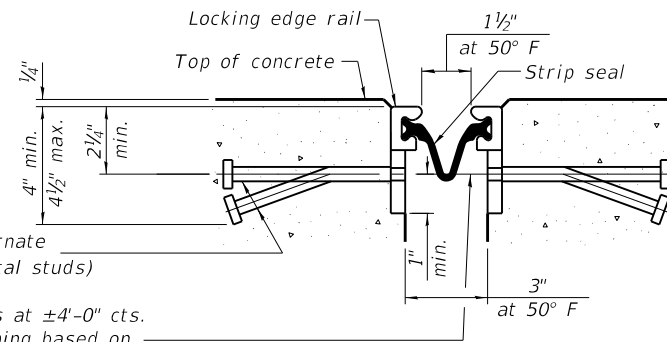

SHOWING WELDED RAIL JOINT

* 5/8" Ø x 6" studs @ 6" cts. (alternate angled/bent studs with horizontal studs)

3/8" Ø threaded rods in 7/16" Ø holes at ±4'-0" cts. for holding the proper joint opening based on the temperature during the deck pour. Place to miss studs. All rods shall be burned, or sawed off flush with the plates after concrete is set.

SECTION THRU JOINT

* Granular or solid flux filled headed studs conforming to Article 1006.32 of the Std. Specs., automatically end welded.

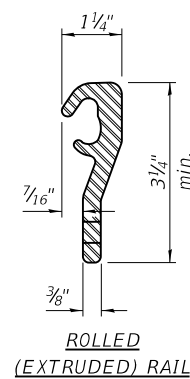

ROLLED (EXTRUDED) RAIL

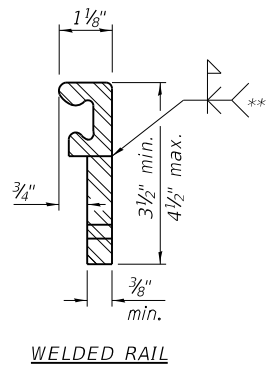

WELDED RAIL

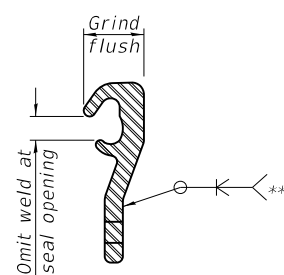

LOCKING EDGE RAIL SPLICE

The inside of the locking edge rail groove shall be free of weld residue. Rolled rail shown, welded rail similar.

LOCKING EDGE RAILS

** Back gouge not required if complete joint penetration is verified by mock-up.

Notes:

The strip seal shall be made continuous and shall have a minimum thickness of 1/4". The configuration of the strip seal shall match the configuration of the locking edge rails. Open or "webbed" strip seal gland configurations are not permitted. The gland shall be sized for a maximum rated movement of 4 inches.

The locking edge rails depicted are configured for typical applications and are conceptual only. The actual configuration of the locking edge rails and matching strip seal may vary from manufacturer to manufacturer provided they fit the application and meet the minimum anchorage shown. Flanged edge rails, however, will not be allowed. Locking edge rails may exceed the 4 1/2" maximum depth provided the anchorage system is revised according to the manufacturer's recommendation.

The manufacturer's recommended installation methods shall be followed.

All steel components shall be galvanized after fabrication according to Article 520.03 of the Standard Specifications.

The Maximum space between locking edge rail segments shall be 3/16" and sealed with a suitable sealant; however, any rail joint within 10' measured perpendicular to the face of the curb or parapet shall be welded as shown in the locking edge rail splice detail.

The top surface of sidewalk sliding plates shall have a raised pattern according to ASTM A786.

Cost of parapet sliding plates, sidewalk sliding plates, embedded plates, anchorage studs, and expansion anchors included with Preformed Joint Strip Seal.

39" constant slope barrier shown, 44" constant slope barrier similar as noted.

The concrete opening below the strip seal will vary based on the locking edge rail chosen by the Contractor. Deck and parapet lengths shown elsewhere in the plans are dimensioned to the concrete opening, not the joint opening, and are based on the rolled locking edge rail. If the Contractor elects to use a different locking edge rail, dimensional adjustments may be required. One exception to this would be the strip seal joint at the end of the precast bridge approach slab. For these cases the pavement connector length shall be adjusted, not the length of the bridge approach slab.

The sliding plates and other structural shapes shall be fabricated to satisfy shop drawing details and conform to the configuration of the concrete barrier or sidewalk. The fabrication shall be according to Articles 505.04 through 505.10.

BILL OF MATERIAL

Item	Unit	Total
Preformed Joint Strip Seal	Foot	25

1/16/2022 1:41:24 PM
 FILE NAME = P:\Projects\210200\210200\210200\210200\Civil\Working\Sheets\0162601-099-joint.dgn



USER NAME = dreilly	DESIGNED - CMS	REVISED -
	DRAWN - CMS	REVISED -
PLOT SCALE = 2:0' = 1"	CHECKED - TCG	REVISED -
PLOT DATE = 11/16/2022	DATE - 11/2/2022	REVISED -

STATE OF ILLINOIS
 DEPARTMENT OF TRANSPORTATION

OAKTON STREET OVER THE DES PLAINES RIVER
 PREFORMED JOINT STRIP SEAL DETAILS 1

SCALE: N.T.S. SHEET 9 OF 10 SHEETS STA. TO STA.

F.A.U. RTE.	SECTION	COUNTY	TOTAL SHEETS	SHEET NO.
	20-00224-00-BT	COOK	89	47
			CONTRACT NO. 61J19	
ILLINOIS FED. AID PROJECT				

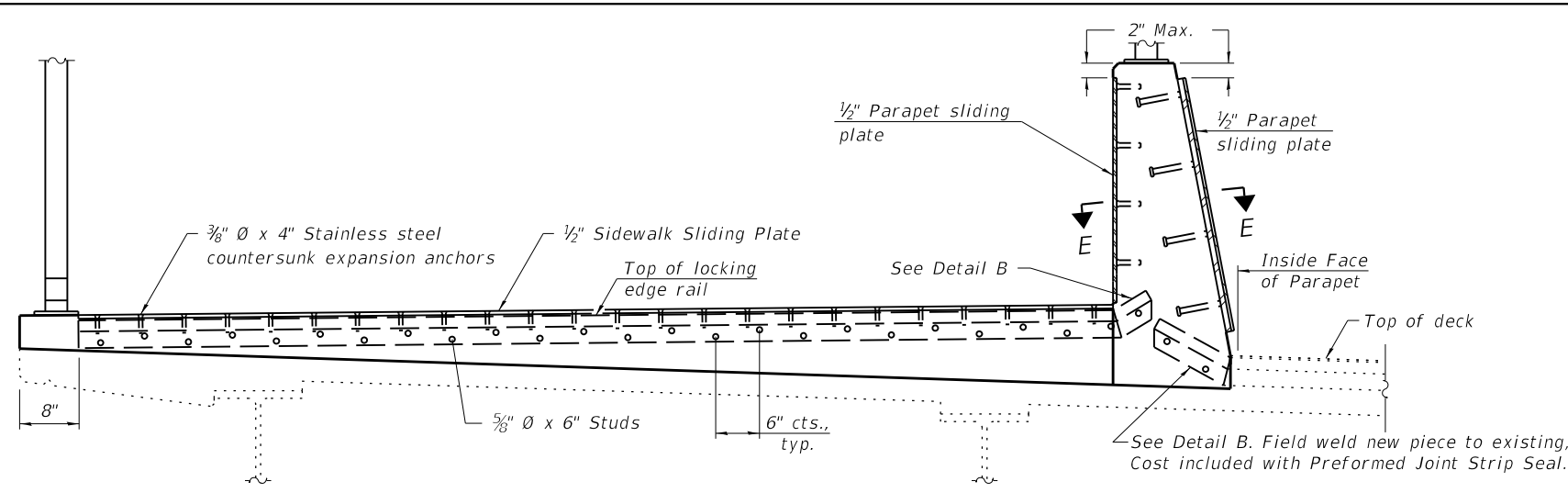

SECTION THRU MULTI-USE PATH

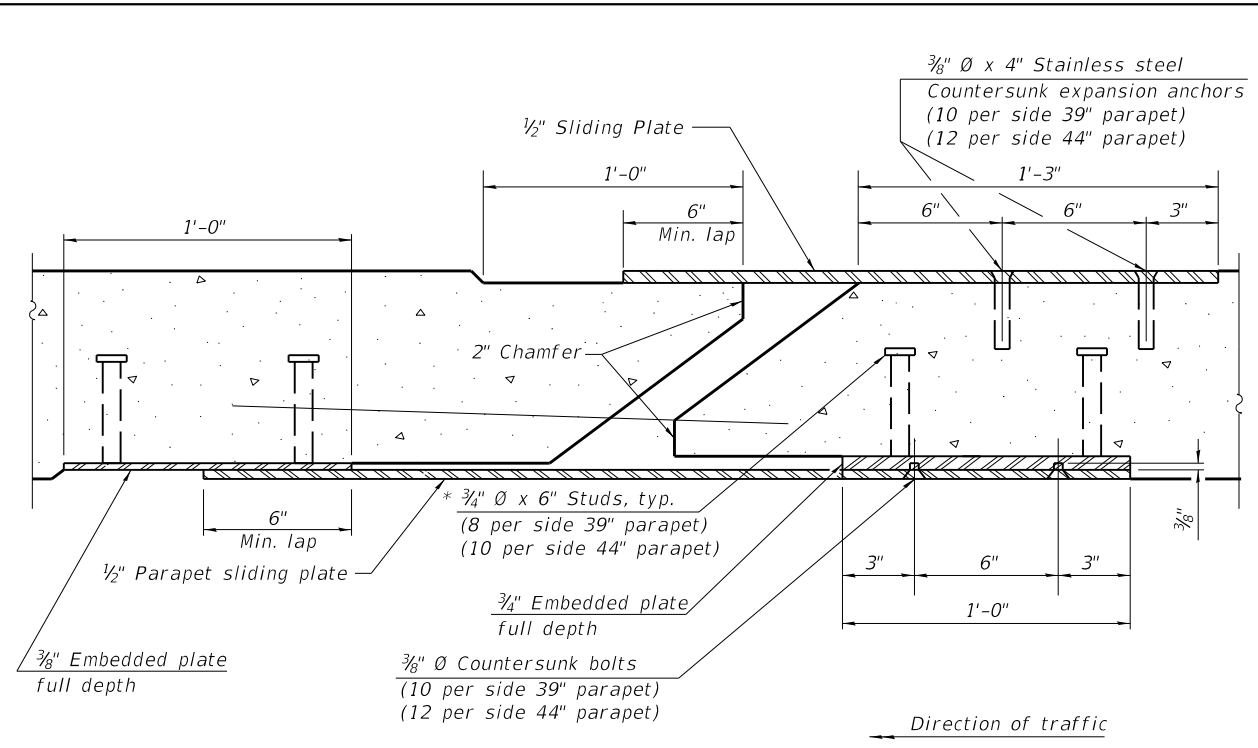

SECTION E-E

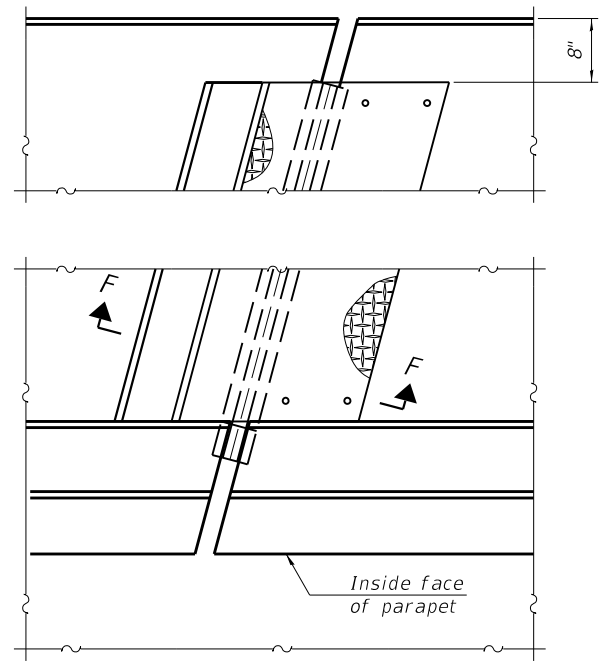

PLAN AT MULTI-USE PATH

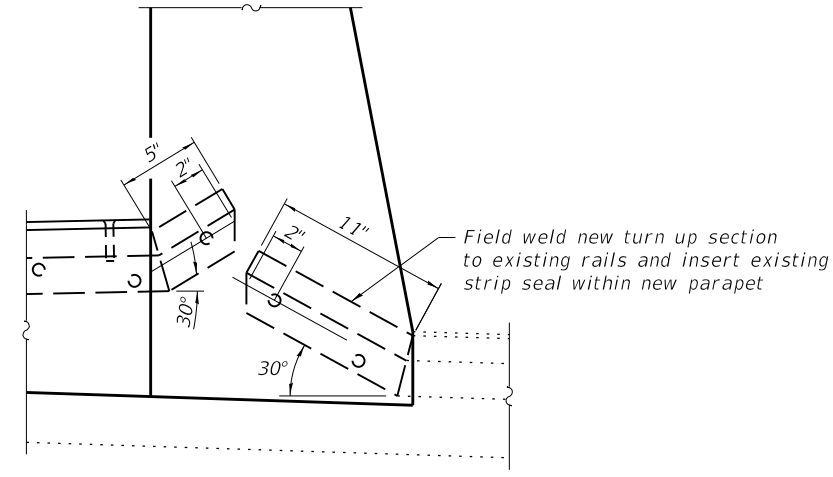

DETAIL B

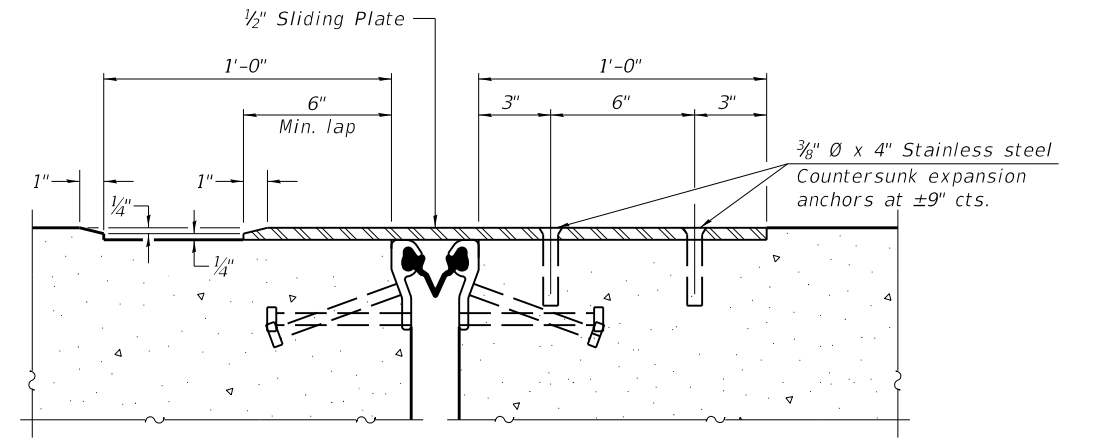

SECTION F-F

11/28/2022 1:20:03 PM
 FILE NAME: P:\Projects\210000\21953_C_DESIGN\01_Discipline\Civil\Working\Sheets\0162601_010_joint2.dgn



USER NAME = dreilly	DESIGNED - CMS	REVISED -
PLOT SCALE = 2:0 '1' = 1"	DRAWN - CMS	REVISED -
PLOT DATE = 11/28/2022	CHECKED - TCG	REVISED -
	DATE - 11/2/2022	REVISED -

STATE OF ILLINOIS
 DEPARTMENT OF TRANSPORTATION

OAKTON STREET OVER THE DES PLAINES RIVER
 PREFORMED JOINT STRIP SEAL DETAILS 2

SCALE: N.T.S. SHEET 10 OF 10 SHEETS STA. TO STA.

F.A.U. RTE.	SECTION	COUNTY	TOTAL SHEETS	SHEET NO.
	20-00224-00-BT	COOK	89	48
CONTRACT NO. 61J19			ILLINOIS FED. AID PROJECT	

GENERAL NOTES

CAST-IN-PLACE CONCRETE

- ALL WORK AND MATERIALS SHALL BE IN ACCORDANCE WITH THE ILLINOIS DEPARTMENT OF TRANSPORTATION (IDOT) STANDARD SPECIFICATIONS FOR ROAD AND BRIDGE CONSTRUCTION ADAPTED JANUARY 1, 2022 AND THE IDOT SUPPLEMENTAL SPECIFICATIONS AND RECURRING SPECIAL PROVISIONS DATED JANUARY 1, 2023, UNLESS NOTED OTHERWISE.
- ALL EXPOSED CONCRETE EDGES SHALL HAVE A $\frac{3}{4}$ " X 45° CHAMFER, EXCEPT WHERE SHOWN OTHERWISE.
- THE CONTRACTOR SHALL VERIFY ALL DIMENSIONS IN THE FIELD PRIOR TO COMMENCING WORK. THE ENGINEER SHALL BE NOTIFIED OF ANY DISCREPANCIES WHICH MAY EXIST PRIOR TO PROCEEDING WITH THE WORK.

REINFORCEMENT BARS

- REINFORCEMENT BARS DESIGNATED "(E)" SHALL BE EPOXY COATED.
- REINFORCEMENT BAR BENDING DETAILS SHALL BE IN ACCORDANCE WITH THE LATEST "MANUAL OF STANDARD PRACTICE FOR DETAILING REINFORCED CONCRETE STRUCTURES", ACI 315.
- REINFORCEMENT BAR BENDING DIMENSIONS ARE OUT TO OUT.
- BARS NOTED THUS, 3X2-#5 INDICATES 3 LINES OF BARS WITH 2 LENGTHS OF BARS PER LINE.
- COVER FROM THE FACE OF CONCRETE TO FACE OF REINFORCEMENT BARS SHALL BE 3" FOR SURFACES FORMED AGAINST EARTH AND 2" FOR ALL OTHER SURFACES UNLESS OTHERWISE SHOWN.

CONSTRUCTION

- CONTRACTOR SHALL NOT SCALE DIMENSIONS FROM THE CONTRACT PLANS FOR CONSTRUCTION PURPOSES. SCALES SHOWN ARE FOR INFORMATION ONLY.
- NO CONSTRUCTION JOINTS EXCEPT THOSE SHOWN ON THE PLANS SHALL BE ALLOWED UNLESS APPROVED BY THE ENGINEER.
- IT SHALL BE THE CONTRACTOR'S RESPONSIBILITY TO VERIFY THE LOCATION OF ALL UTILITIES PRIOR TO STARTING CONSTRUCTION. CONTACT J.U.L.I.E., 800-892-0123.
- THE SOIL BORING LOGS REPRESENT POINT INFORMATION. PRESENTATION OF THIS INFORMATION IN NO WAY IMPLIES THAT SUBSURFACE CONDITIONS ARE THE SAME AT LOCATIONS OTHER THAN THE EXACT LOCATION OF THE BORING.

- WHENEVER ANY MATERIAL IS DEPOSITED INTO A DRAINAGE SYSTEM OR DRAINAGE STRUCTURES, THE DEPOSITED MATERIAL SHALL BE REMOVED AT THE CLOSE OF EACH WORKING DAY. AT THE CONCLUSION OF CONSTRUCTION OPERATIONS, ALL DRAINAGE SYSTEMS AND STRUCTURES SHALL BE FREE FROM DIRT AND DEBRIS DEPOSITED DURING THE VARIOUS CONSTRUCTION OPERATIONS.

- PROTECTIVE COAT SHALL BE APPLIED TO THE TOP SURFACE OF THE SIDEWALK.

RETAINING WALL

DESIGN LOADS:
LATERAL EARTH PRESSURE=EQUIVALENT FLUID PRESSURE (PSF/FT)

	DRAINED CONDITION	UNDRAINED CONDITION
ACTIVE STATE	50	90
PASSIVE STATE	320	220
WATER PRESSURE = 62.4 PSF/FT		
SURCHARGE = 75 PSF		

ABBREVIATIONS

P.G.L.	PROFILE GRADE LINE
N.B.	NORTH BOUND
S.B.	SOUTH BOUND
N. ABUT.	NORTH ABUTMENT
S. ABUT.	SOUTH ABUTMENT
E.F.	EACH FACE
F.F.	FRONT FACE
B.F.	BACK FACE
I.F.	INSIDE FACE
O.F.	OUTSIDE FACE
P.J.F.	PREFORMED JOINT FILLER
P.J.S.	PREFORMED JOINT SEALER
BK/	BACK OF
B/	BOTTOM OF
T/	TOP OF
PROP.	PROPOSED
EXIST.	EXISTING

TOTAL BILL OF MATERIAL

PAY ITEM NO.	ITEM	UNIT	QUANTITY	RECORD QUANTITY
20900110	POROUS GRANULAR BACKFILL	CU YD	70	
35101600	AGGREGATE BASE COURSE, TYPE B 4"	SQ YD	890	
42001300	PROTECTIVE COAT	SQ YD	1830	
50200100	STRUCTURE EXCAVATION	CU YD	185	
50300225	CONCRETE STRUCTURES	CU YD	300.6	
50800205	REINFORCEMENT BARS, EPOXY COATED	POUND	22230	
50901750	BICYCLE RAILING	FOOT	615	
52200015	PERMANENT SHEET PILING	SQ FT	10140	

FILE NAME =	USER NAME = mthomas	DESIGNED -	REVISED -	STATE OF ILLINOIS DEPARTMENT OF TRANSPORTATION	OAKTON STREET PROPOSED RETAINING WALL GENERAL NOTES AND SUMMARY OF QUANTITIES	F.A.U RTE.	SECTION	COUNTY	TOTAL SHEETS	SHEET NO.
N:\DESPLAINS\190138.00003\Struct\190138.00003-GNotes.sh	DRAWN -	REVISED -	1332			20-00224-00-BT	COOK	89	49	
Default	PLOT SCALE = 2'	CHECKED -	REVISED -			CONTRACT NO. 61J19				
	PLOT DATE = 11/16/2022	DATE -	REVISED -			SCALE: N.T.S.	SHEET 2 OF 8 SHEETS	STA. 106+81.5 TO STA. 113+00	ILLINOIS FED. AID PROJECT	

ELEVATION BENCHMARKS		
DATUM: NAVD '88 DESPLAINES DATUM		
NO.	DESCRIPTION	ELEV.
BM 59	DESPLAINES MONUMENT SET IN CONCRETE AT SW CORNER OF OAKTON ST. & LEE/MANNHEIM 21' SOUTH OF E/P OF OAKTON ST. & 25' WEST OF E/P OF LEE/MANNHEIM (GPS OBSERVED)	645.78
OSBM 20-1	SQUARE CUT ON SOUTHWEST CORNER OF CONC. WALL ON SOUTH SIDE OF OAKTON ST. BRIDGE OVER THE DES PLAINES RIVER	639.57

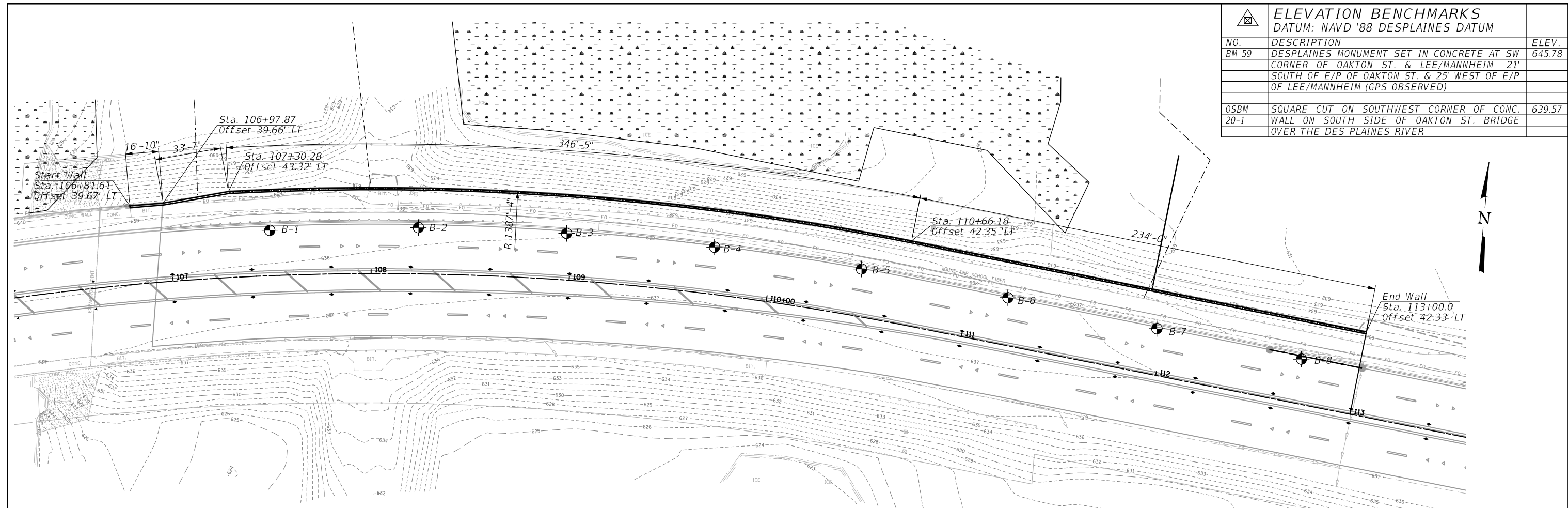

PLAN
NOTE: Offsets are to the outside face of the sheet pile wall.

DESIGN STRESSES
FIELD UNITS
f'c = 3,500 PSI (CAST-IN-PLACE CONCRETE)
fy = 50,000 PSI (STRUCTURAL STEEL) (ASTM A572, GR 50)
fy = 60,000 PSI (REINFORCEMENT BARS)

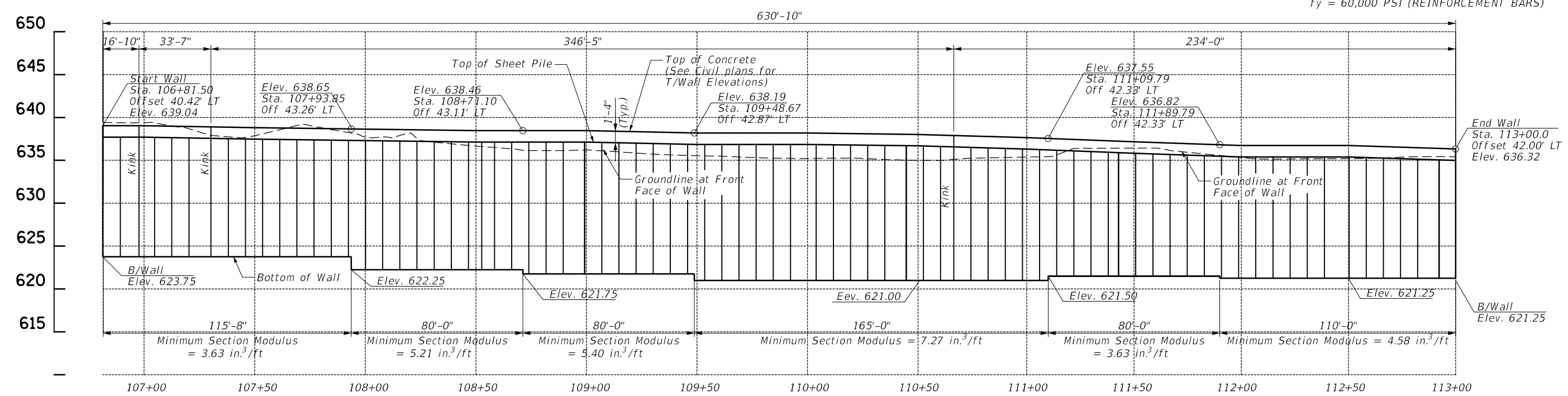

ELEVATION

FILE NAME =	USER NAME = mthomas	DESIGNED -	REVISED -
N:\DESPLAINES\190138.00003\Struct\190138	00003-Wall.Elev-01.sht	DRAWN -	REVISED -
Default	PLOT SCALE = 5/8"	CHECKED -	REVISED -
	PLOT DATE = 11/16/2022	DATE -	REVISED -

STATE OF ILLINOIS
DEPARTMENT OF TRANSPORTATION

OAKTON STREET
PROPOSED RETAINING WALL
PLAN AND ELEVATION
SCALE: N.T.S. SHEET 1 OF 8 SHEETS STA. 106+81.5 TO STA. 113+00

F.A.U. R.E.	SECTION	COUNTY	TOTAL SHEETS	SHEET NO.
1332	20-00224-00-BT	COOK	89	50
CONTRACT NO. 61J19				
ILLINOIS FED. AID PROJECT				

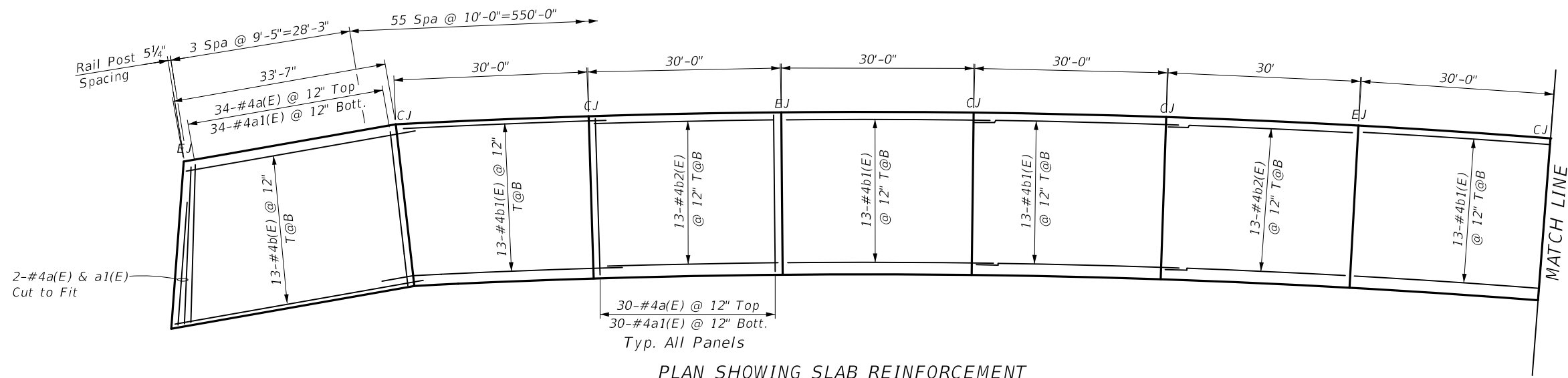

PLAN SHOWING SLAB REINFORCEMENT

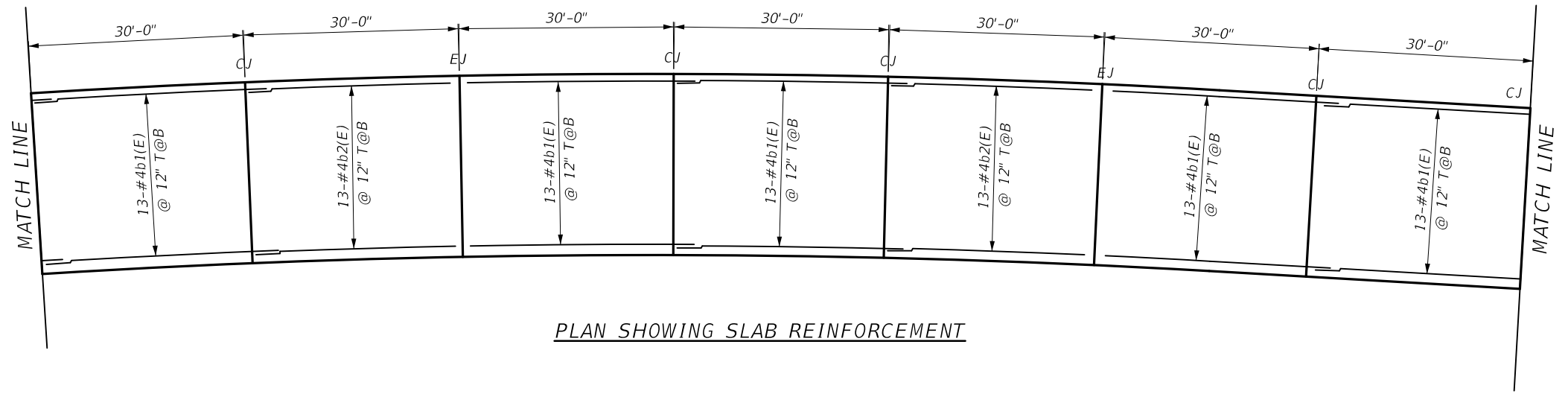

PLAN SHOWING SLAB REINFORCEMENT

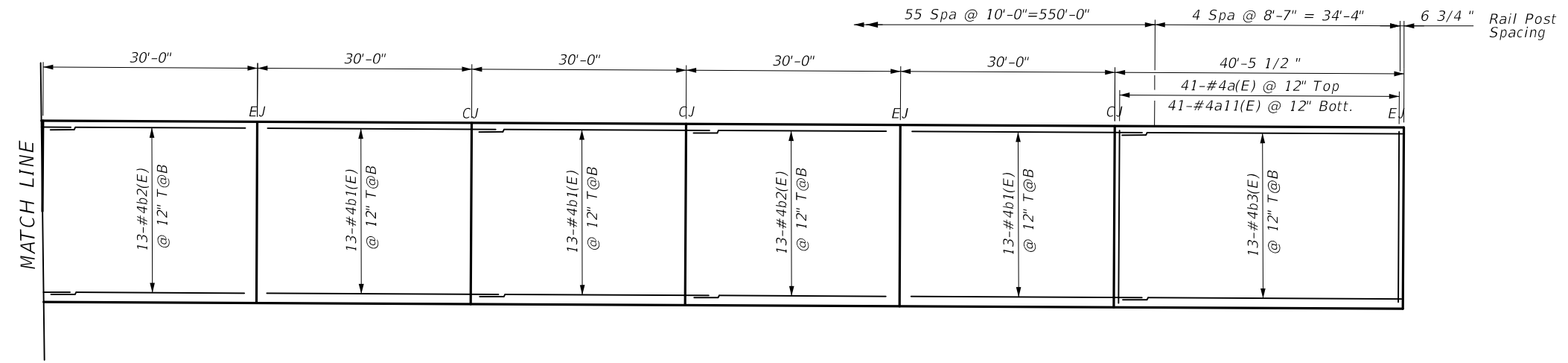

PLAN SHOWING SLAB REINFORCEMENT

BILL OF MATERIAL

Bar	No.	Size	Length	Shape
a(E)	617	#4	13'-4"	—
a1(E)	617	#4	12'-4"	—
b(E)	27	#4	37'-7"	—
b1(E)	324	#4	32'-7"	—
b2(E)	162	#4	29'-8"	—
b3(E)	27	#4	39'-8"	—
Reinforcement Bars, Epoxy Coated			Lbs.	22,230

MINIMUM BAR LAP

#4 Bar = 2'-7"

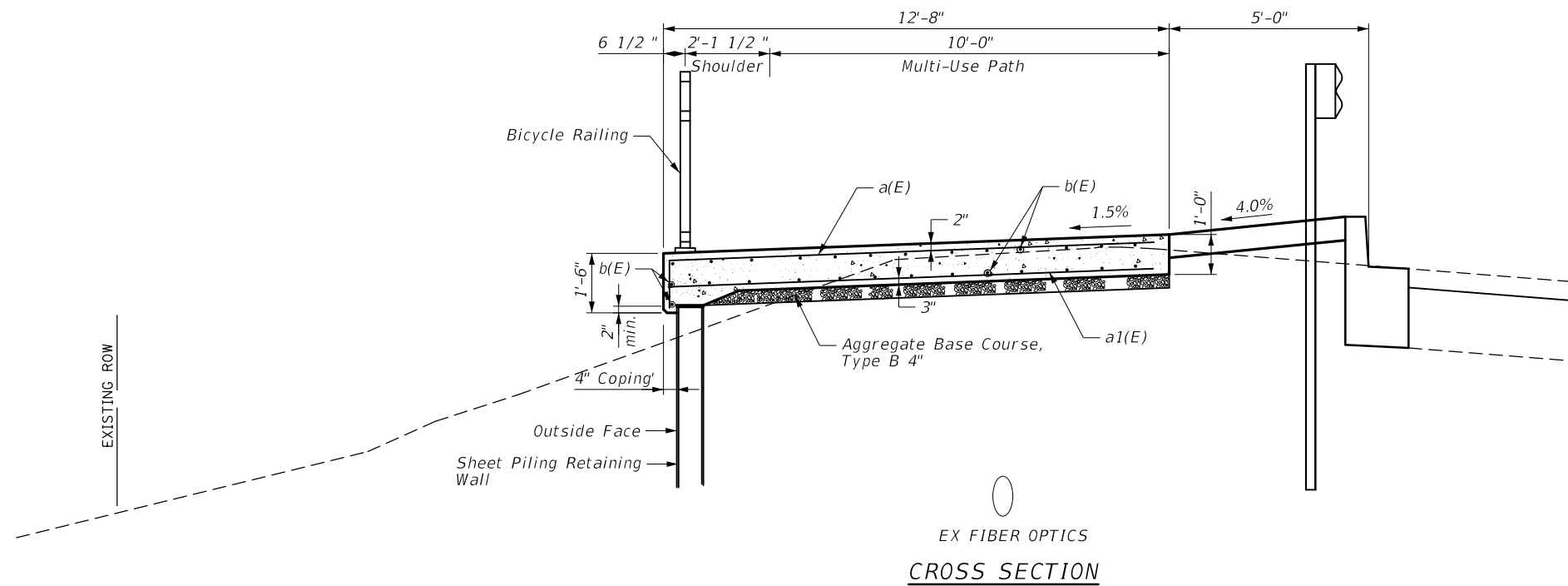

Non-staining Gray one Component non-sag Elastomeric Gun Grade Polyurethane Sealant Meeting the Requirements of ASTM C-920, Type S, Grade NS, Class 25, use T with A Backer Rod

Non-staining Gray one Component non-sag Elastomeric Gun Grade Polyurethane Sealant Meeting the Requirements of ASTM c-920, Type S, Grade NS, Class 25, use T with A Backer Rod

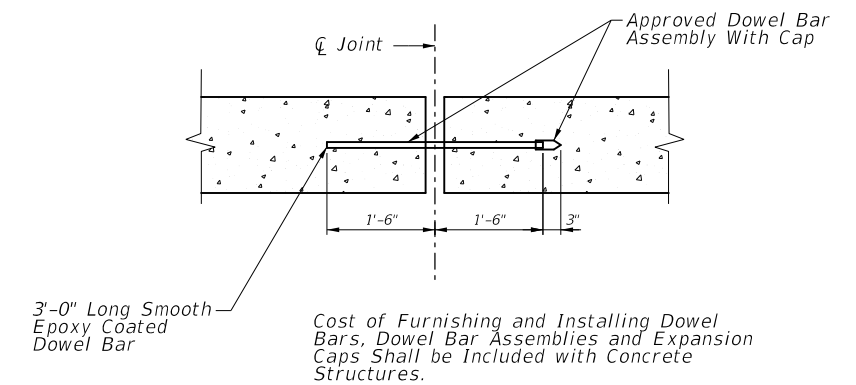
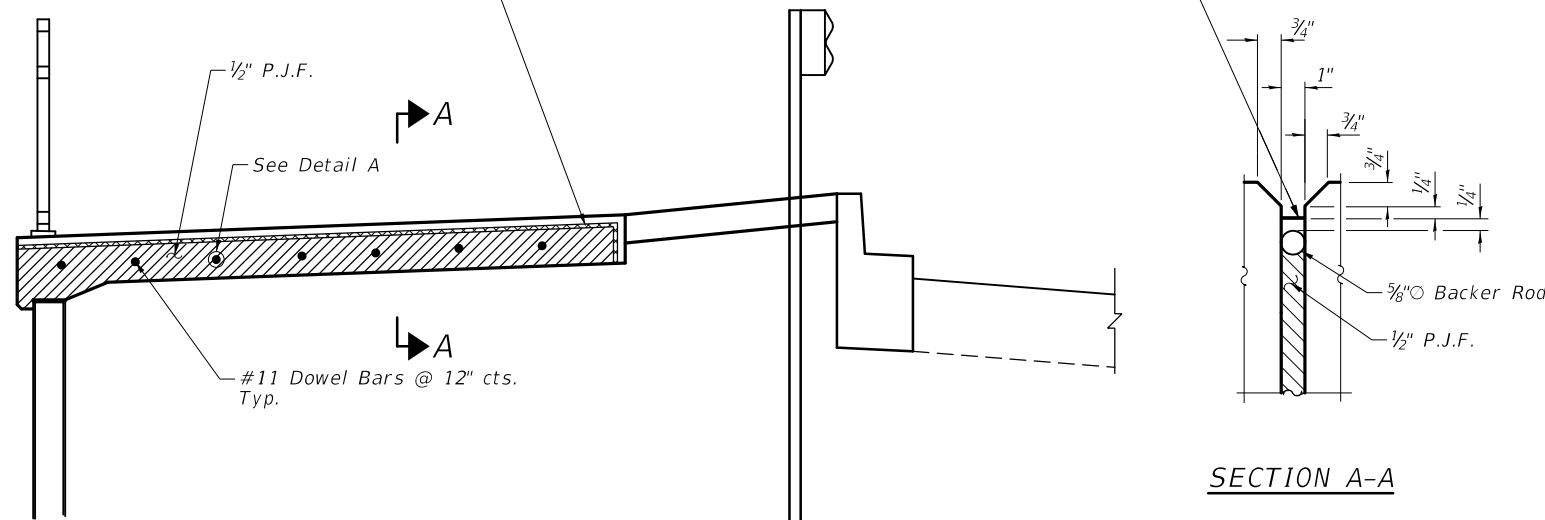

FILE NAME =	USER NAME = mthomas	DESIGNED -	REVISED -
N:\DESPLAINS\190138.00003\Struct\190138	00003-Slab Det.sht	DRAWN -	REVISED -
Default	PLOT SCALE = 28"	CHECKED -	REVISED -
	PLOT DATE = 11/16/2022	DATE -	REVISED -

**STATE OF ILLINOIS
DEPARTMENT OF TRANSPORTATION**

**OAKTON STREET
PROPOSED RETAINING WALL
CROSS SECTION AND EXPANSION JOINT DETAIL**

SCALE: N.T.S. SHEET 4 OF 8 SHEETS STA. 106+81.5 TO STA. 113+00

F.A.U. RTE.	SECTION	COUNTY	TOTAL SHEETS	SHEET NO.
1332	20-00224-00-BT	COOK	89	52
CONTRACT NO. 61J19				
ILLINOIS FED. AID PROJECT				

PROJECT **Sheet Pile Wall, Oakton Street East of Des Plaines River Road, Cook County, IL** **TSC**
 CLIENT **Christopher B. Burke Engineering, Ltd, Rosemont, Illinois**
 BORING **1** DATE STARTED **2-11-22** DATE COMPLETED **2-11-22** JOB **L-93,325**
 ELEVATIONS WATER LEVEL OBSERVATIONS
 GROUND SURFACE **638.5** WHILE DRILLING **3.0'**
 END OF BORING **618.5** AT END OF BORING **Dry**
 24 HOURS

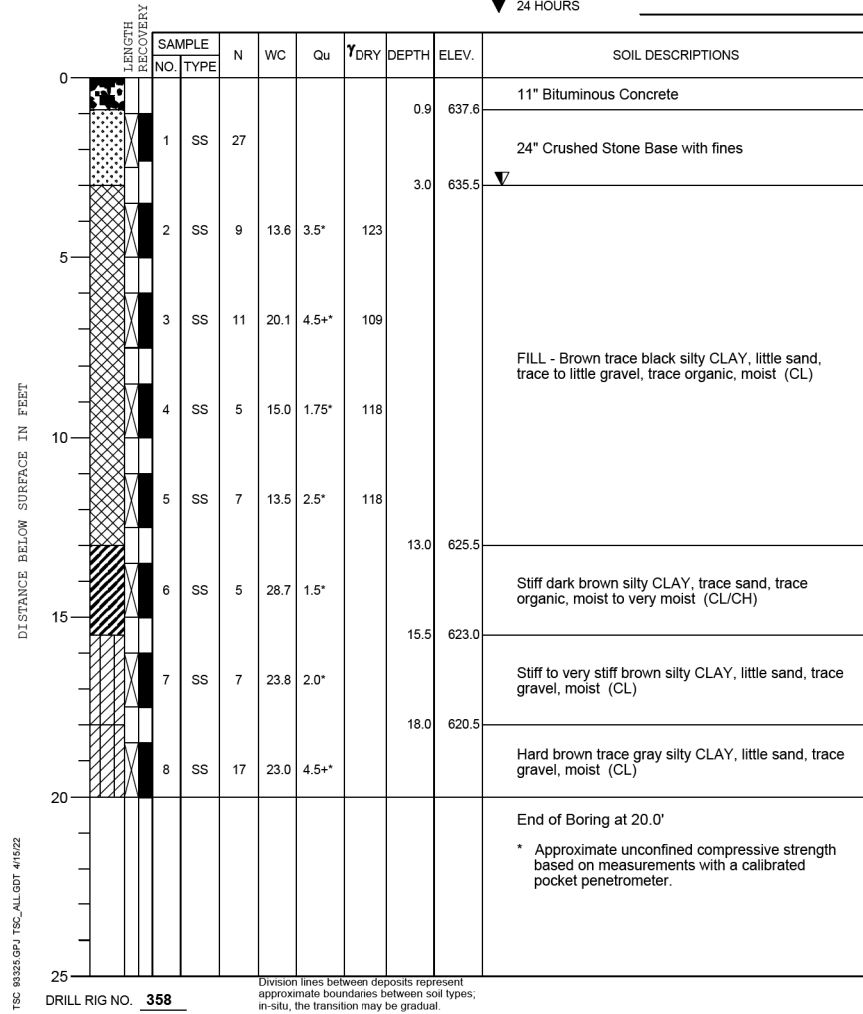

PROJECT **Sheet Pile Wall, Oakton Street East of Des Plaines River Road, Cook County, IL** **TSC**
 CLIENT **Christopher B. Burke Engineering, Ltd, Rosemont, Illinois**
 BORING **2** DATE STARTED **2-11-22** DATE COMPLETED **2-11-22** JOB **L-93,325**
 ELEVATIONS WATER LEVEL OBSERVATIONS
 GROUND SURFACE **638.5** WHILE DRILLING **18.0'**
 END OF BORING **618.5** AT END OF BORING **18.0'**
 24 HOURS

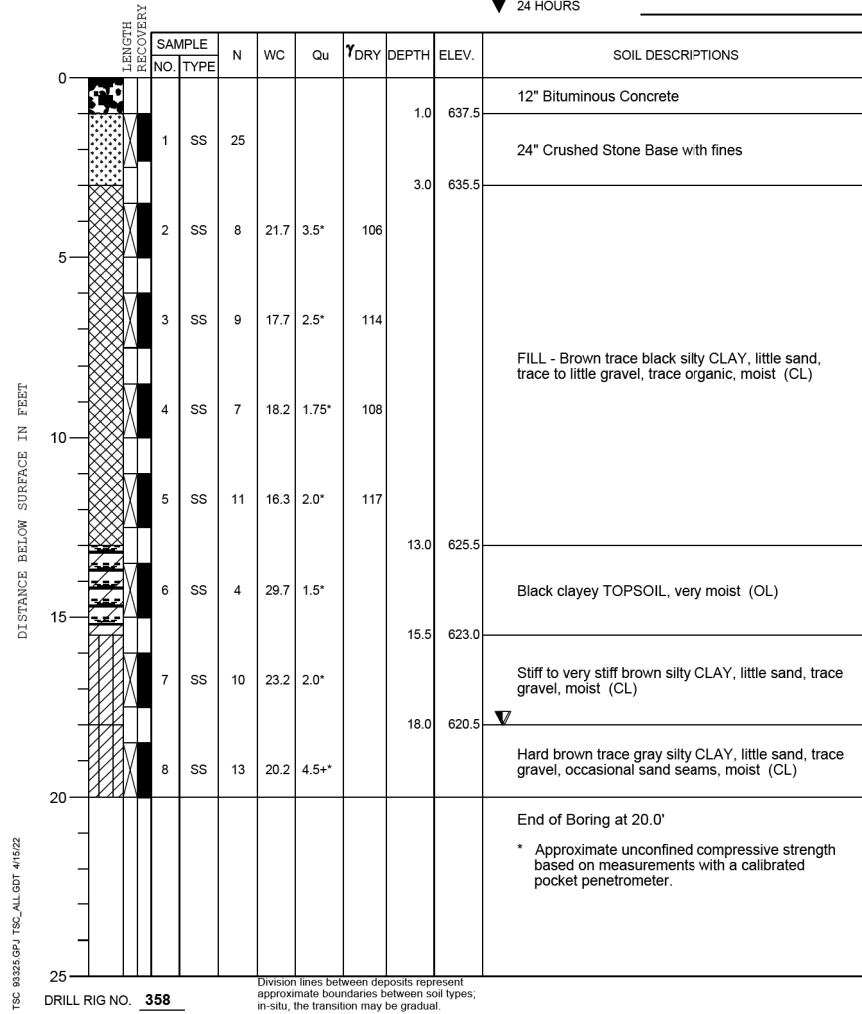

PROJECT **Sheet Pile Wall, Oakton Street East of Des Plaines River Road, Cook County, IL** **TSC**
 CLIENT **Christopher B. Burke Engineering, Ltd, Rosemont, Illinois**
 BORING **3** DATE STARTED **2-11-22** DATE COMPLETED **2-11-22** JOB **L-93,325**
 ELEVATIONS WATER LEVEL OBSERVATIONS
 GROUND SURFACE **638.0** WHILE DRILLING **18.0'**
 END OF BORING **618.0** AT END OF BORING **18.0'**
 24 HOURS

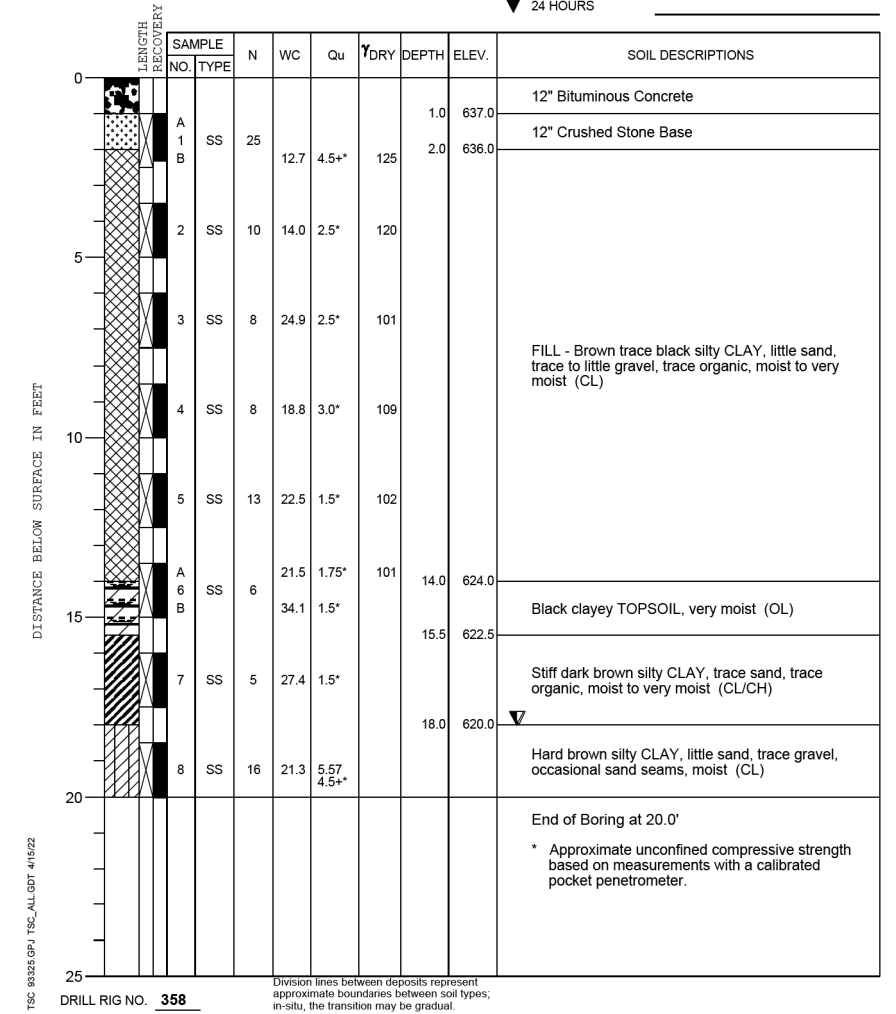

PROJECT **Sheet Pile Wall, Oakton Street East of Des Plaines River Road, Cook County, IL** **TSC**
 CLIENT **Christopher B. Burke Engineering, Ltd, Rosemont, Illinois**
 BORING **4** DATE STARTED **2-11-22** DATE COMPLETED **2-11-22** JOB **L-93,325**
 ELEVATIONS WATER LEVEL OBSERVATIONS
 GROUND SURFACE **638.0** WHILE DRILLING **21.0'**
 END OF BORING **615.5** AT END OF BORING **21.0'**
 24 HOURS

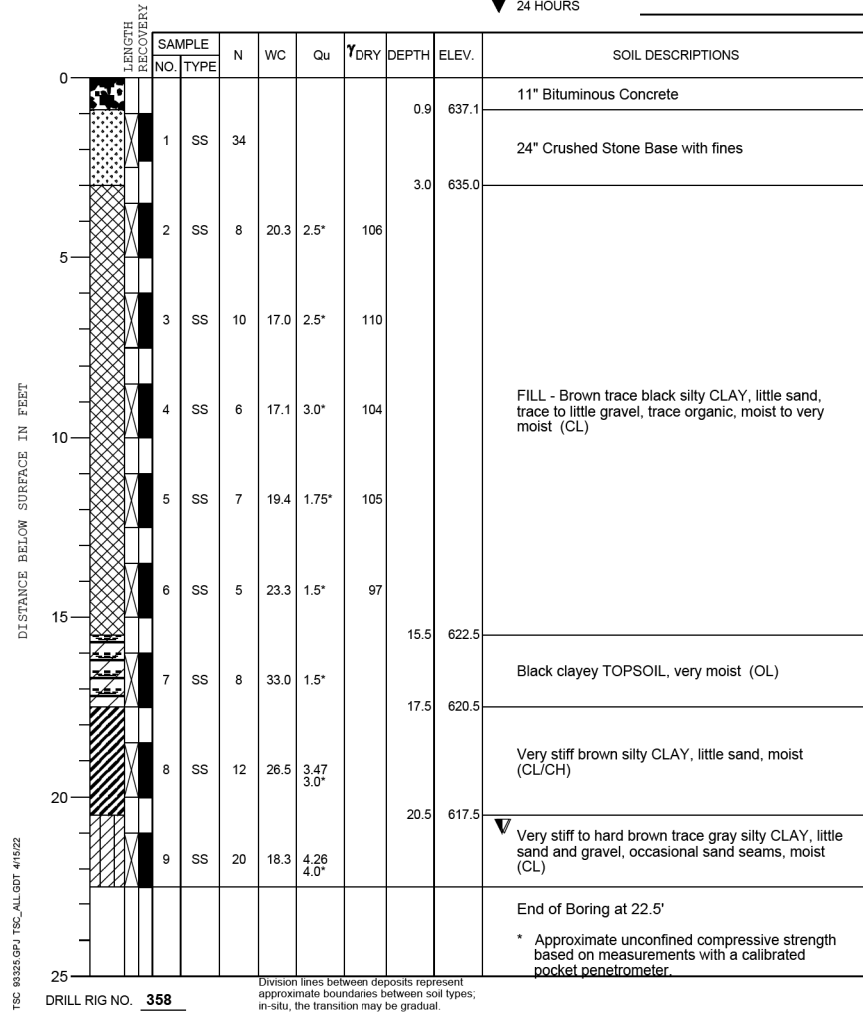

PROJECT **Sheet Pile Wall, Oakton Street East of Des Plaines River Road, Cook County, IL** **TSC**
 CLIENT **Christopher B. Burke Engineering, Ltd, Rosemont, Illinois**
 BORING **5** DATE STARTED **2-11-22** DATE COMPLETED **2-11-22** JOB **L-93,325**
 ELEVATIONS WATER LEVEL OBSERVATIONS
 GROUND SURFACE **637.5** WHILE DRILLING **3.0'**
 END OF BORING **622.5** AT END OF BORING **Dry**
 24 HOURS

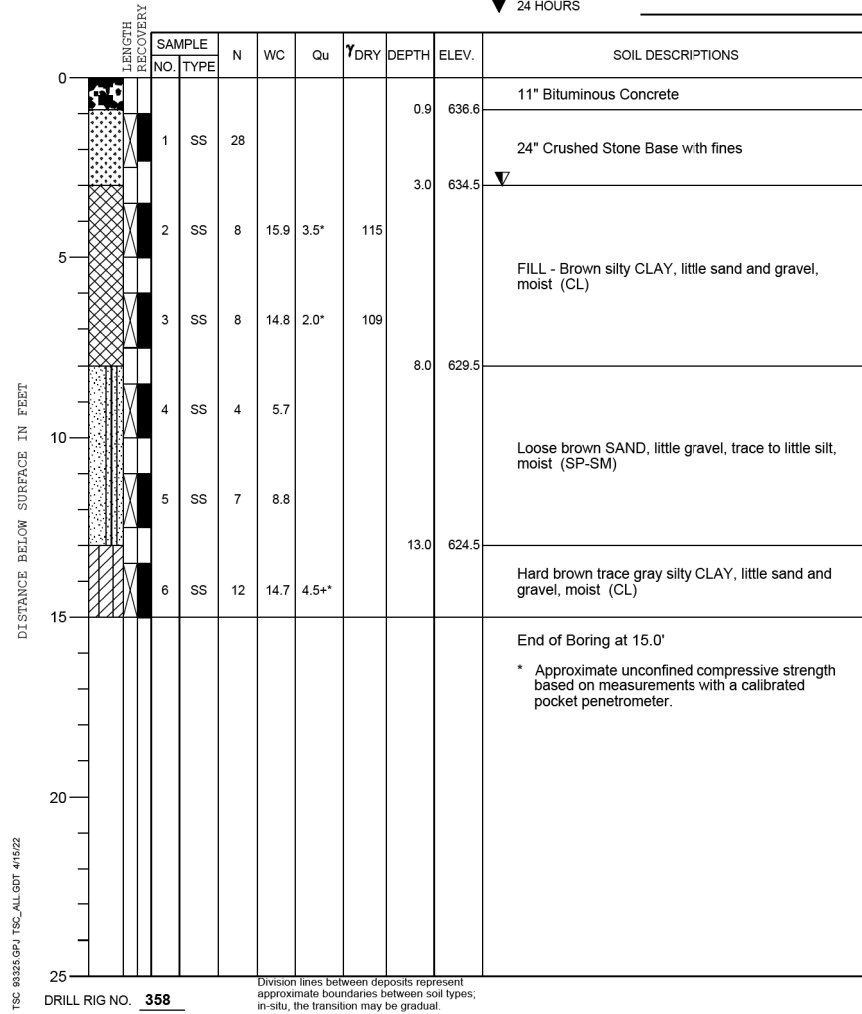

PROJECT **Sheet Pile Wall, Oakton Street East of Des Plaines River Road, Cook County, IL** **TSC**
 CLIENT **Christopher B. Burke Engineering, Ltd, Rosemont, Illinois**
 BORING **6** DATE STARTED **2-11-22** DATE COMPLETED **2-11-22** JOB **L-93,325**
 ELEVATIONS WATER LEVEL OBSERVATIONS
 GROUND SURFACE **637.0** WHILE DRILLING **Dry**
 END OF BORING **619.5** AT END OF BORING **Dry**
 24 HOURS

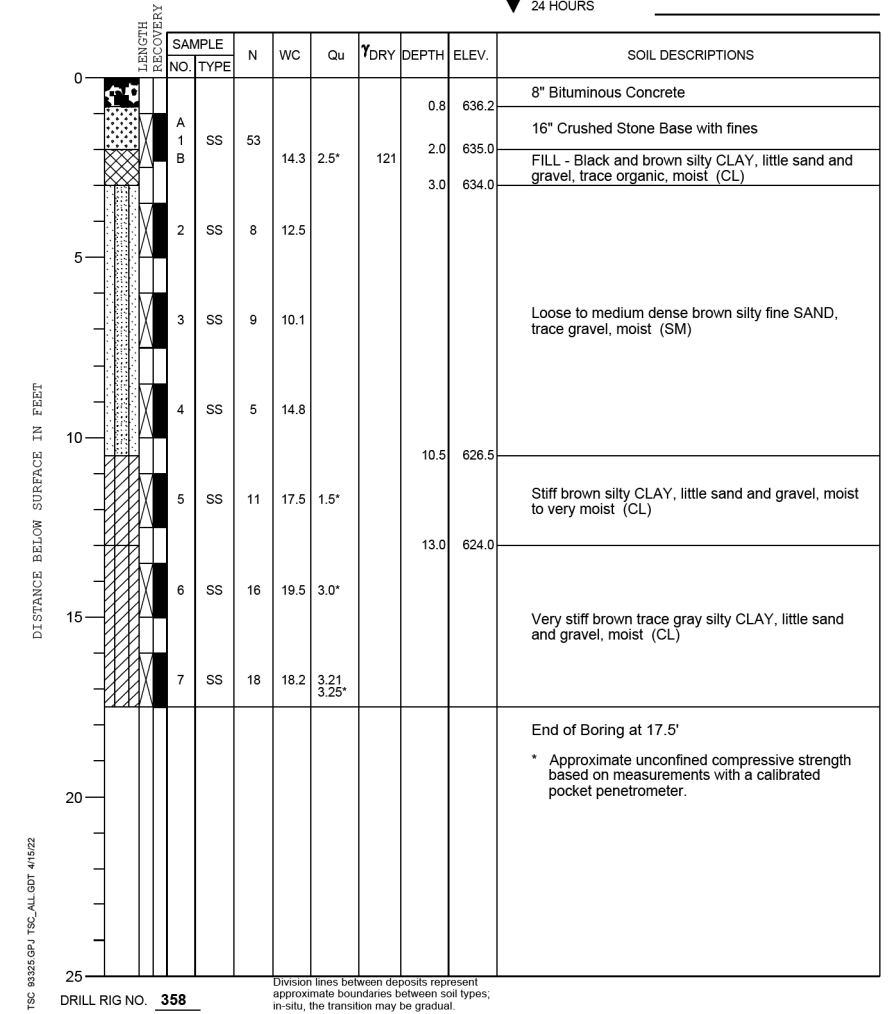

PROJECT **Sheet Pile Wall, Oakton Street East of Des Plaines River Road, Cook County, IL**



CLIENT **Christopher B. Burke Engineering, Ltd, Rosemont, Illinois**

BORING **7** DATE STARTED **2-11-22** DATE COMPLETED **2-11-22** JOB **L-93,325**

ELEVATIONS WATER LEVEL OBSERVATIONS
 GROUND SURFACE **636.5** WHILE DRILLING **Dry**
 END OF BORING **626.5** AT END OF BORING **Dry**
 24 HOURS

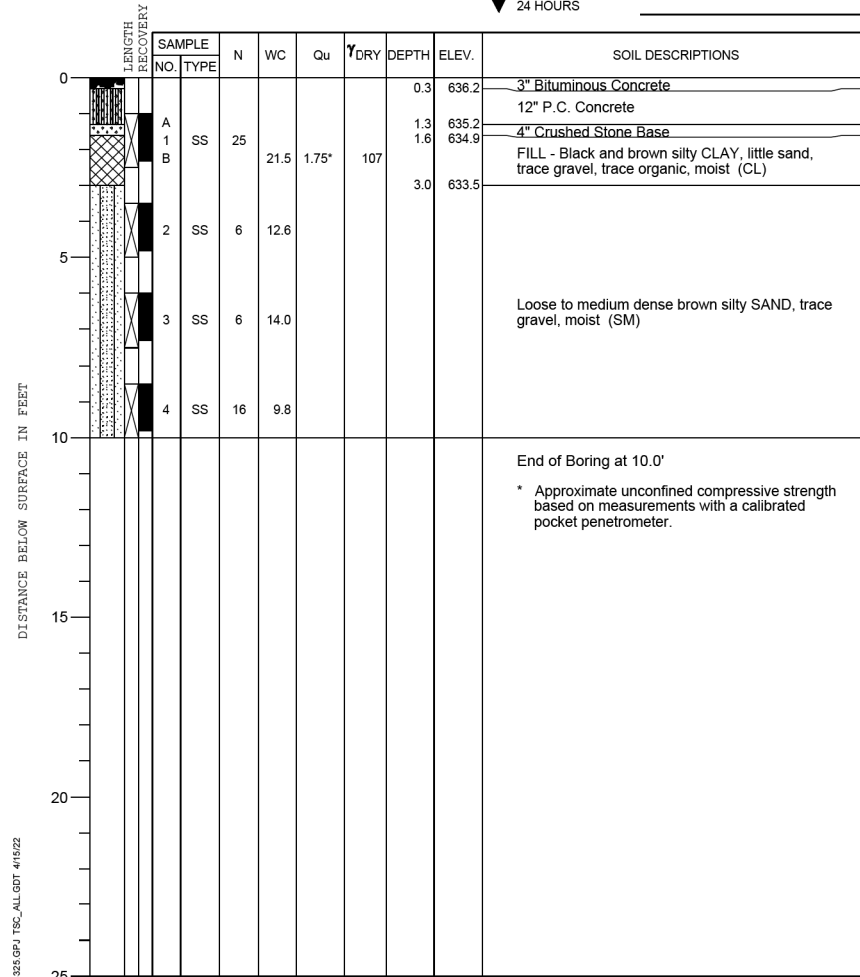

TSC 93325.GPJ TSC_ALL.GDT 4/15/22
 DRILL RIG NO. **358**

Division lines between deposits represent approximate boundaries between soil types; in-situ, the transition may be gradual.

PROJECT **Sheet Pile Wall, Oakton Street East of Des Plaines River Road, Cook County, IL**



CLIENT **Christopher B. Burke Engineering, Ltd, Rosemont, Illinois**

BORING **8** DATE STARTED **2-11-22** DATE COMPLETED **2-11-22** JOB **L-93,325**

ELEVATIONS WATER LEVEL OBSERVATIONS
 GROUND SURFACE **636.0** WHILE DRILLING **10.5'**
 END OF BORING **623.5** AT END OF BORING **9.0'**
 24 HOURS

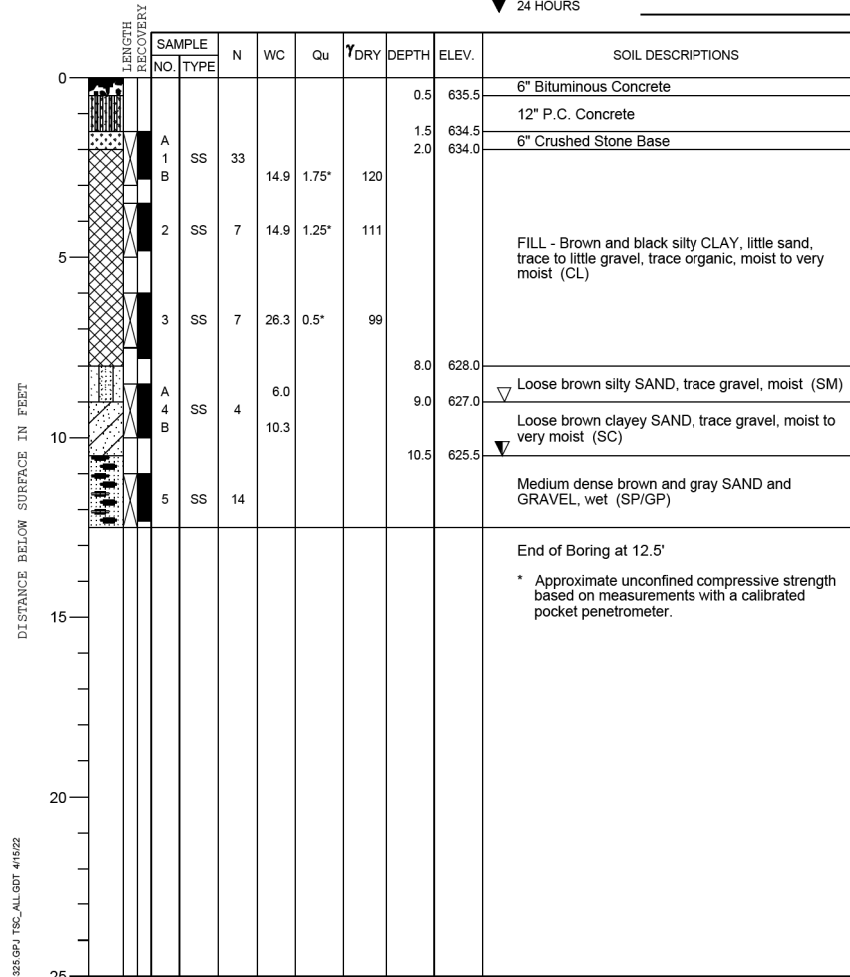

TSC 93325.GPJ TSC_ALL.GDT 4/15/22
 DRILL RIG NO. **358**

Division lines between deposits represent approximate boundaries between soil types; in-situ, the transition may be gradual.

FILE NAME =	USER NAME = mthomas	DESIGNED -	REVISED -	STATE OF ILLINOIS DEPARTMENT OF TRANSPORTATION	OAKTON STREET PROPOSED RETAINING WALL BORING LOGS	F.A.U. RTE.	SECTION	COUNTY	TOTAL SHEETS	SHEET NO.	
N:\DESPLAINES\190138.00003\Struct\190138	00003-BLogs-03.sht	DRAWN -	REVISED -			1332	20-00224-00-BT	COOK	89	56	
Default	PLOT SCALE = 2"	CHECKED -	REVISED -			CONTRACT NO. 61J19					
	PLOT DATE = 11/16/2022	DATE -	REVISED -			SCALE: N.T.S.	SHEET 8 OF 8 SHEETS	STA. 106+81.5	TO STA. 113+00	ILLINOIS FED. AID PROJECT	

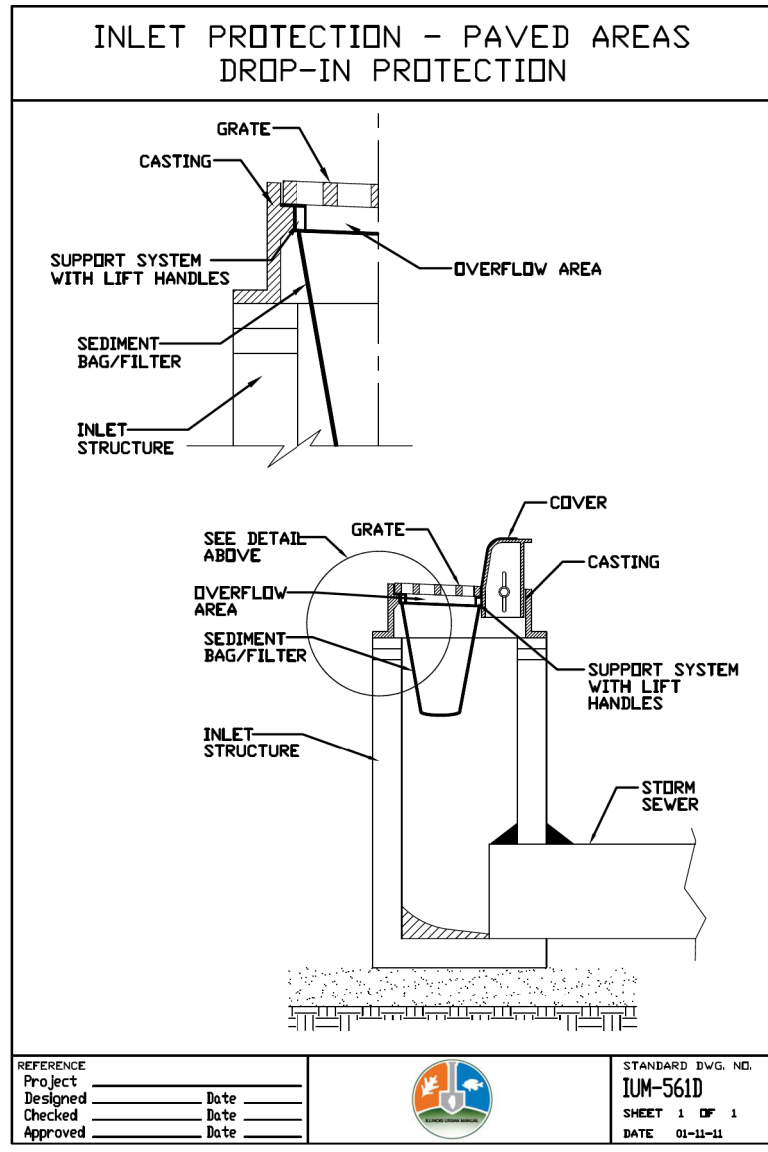

INLET FILTER

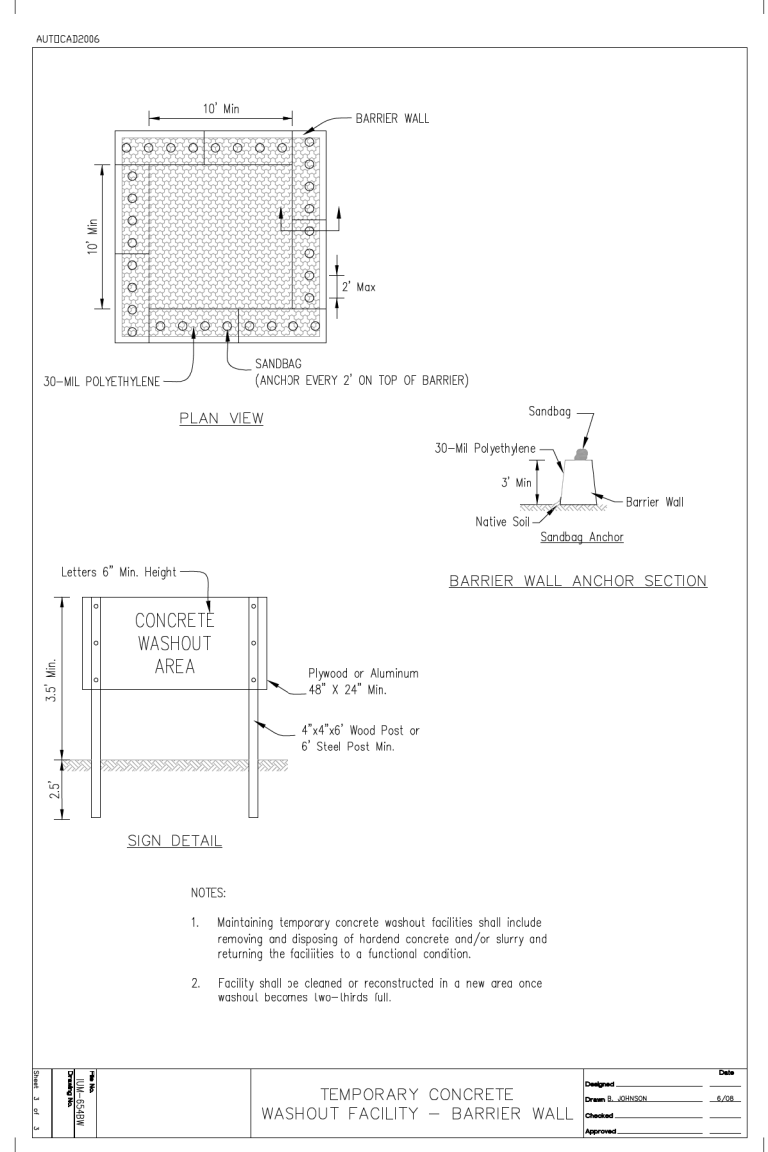
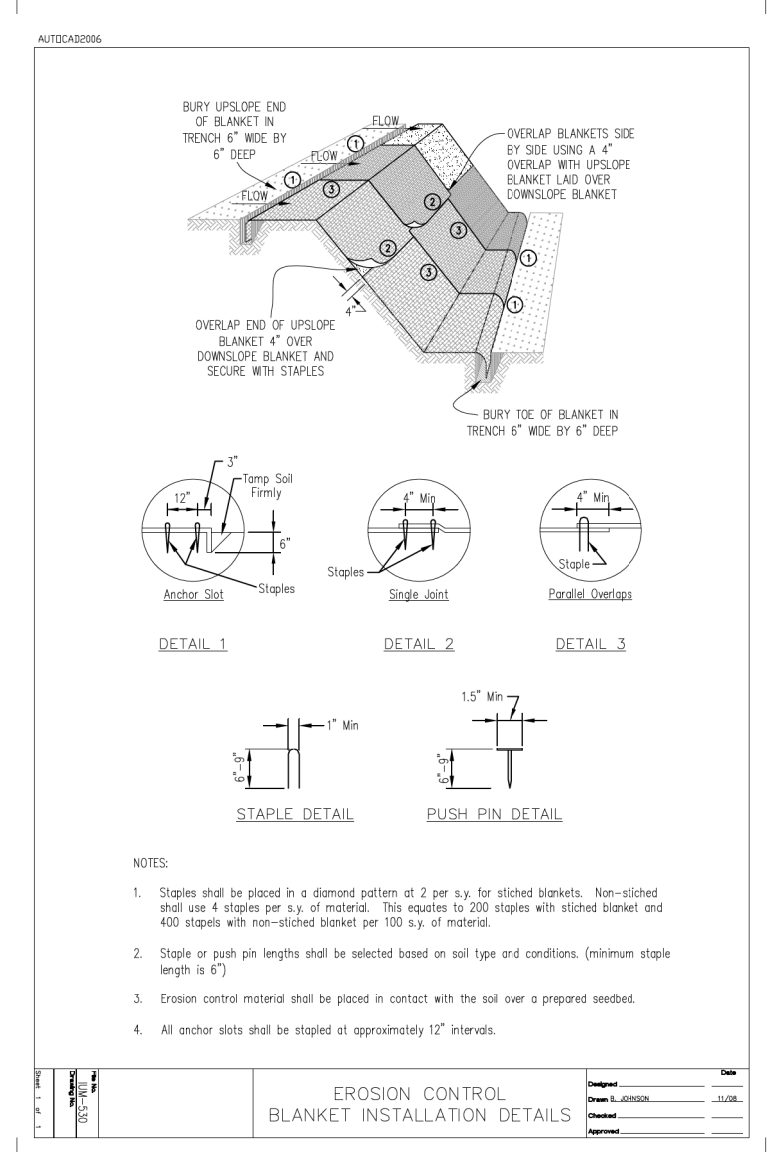

WASHOUT BASIN

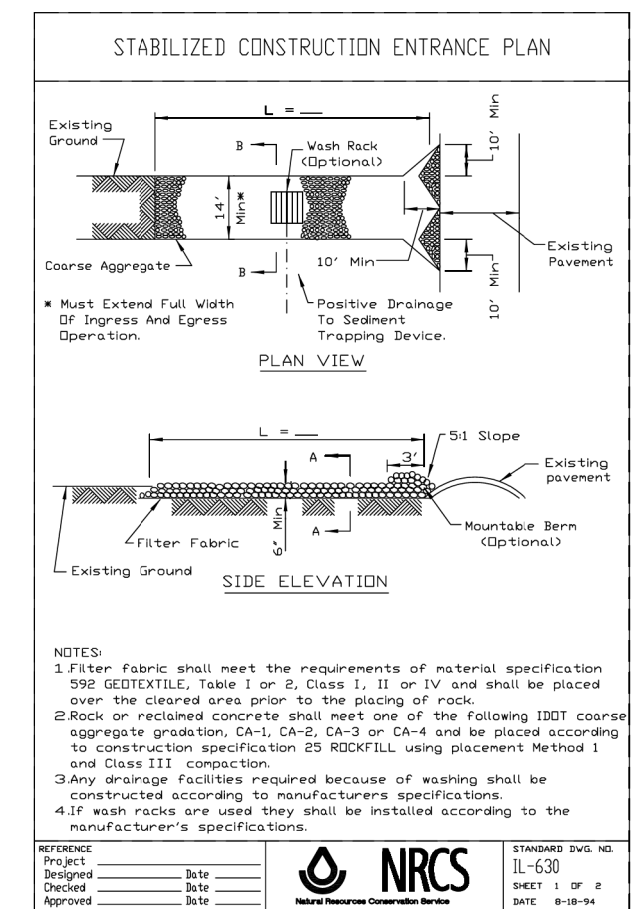
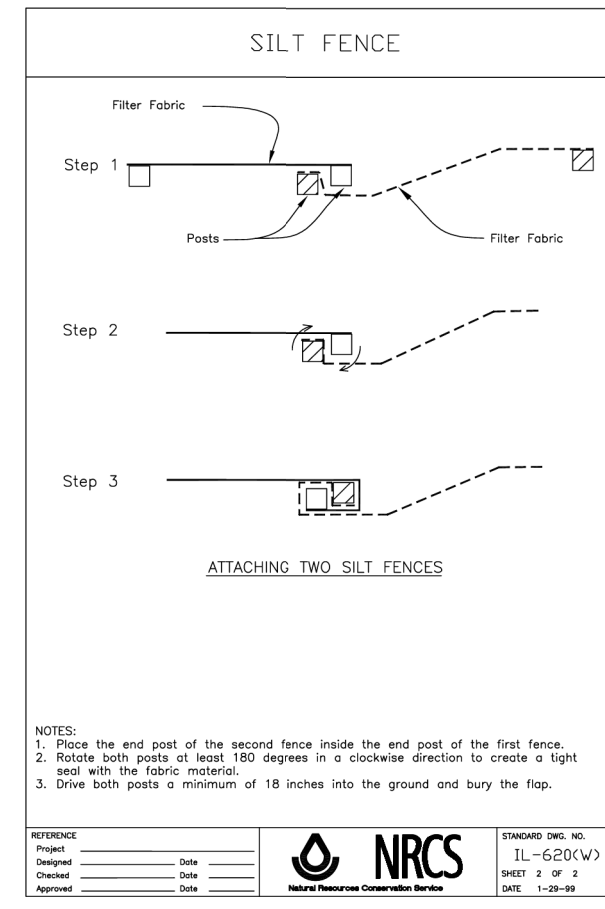
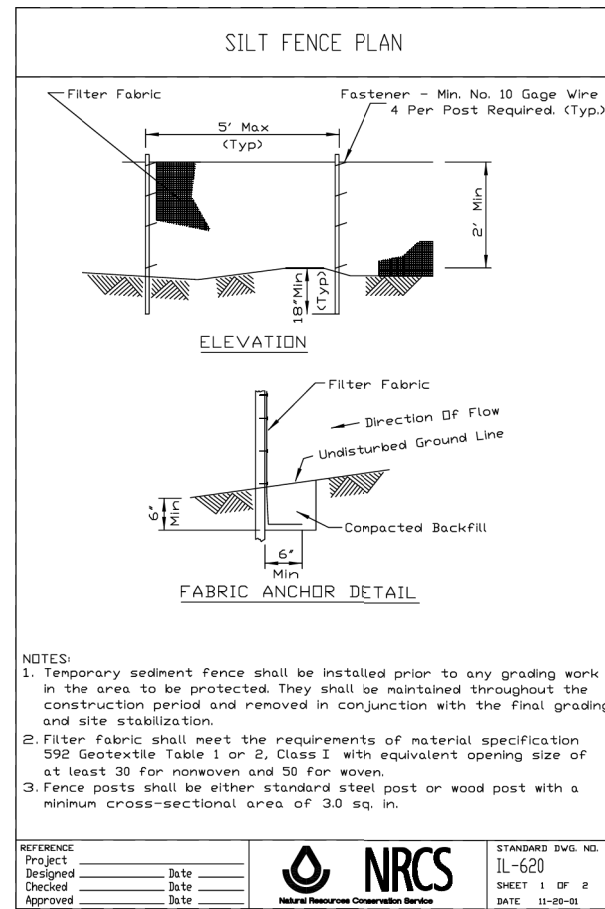

PERIMETER EROSION BARRIER

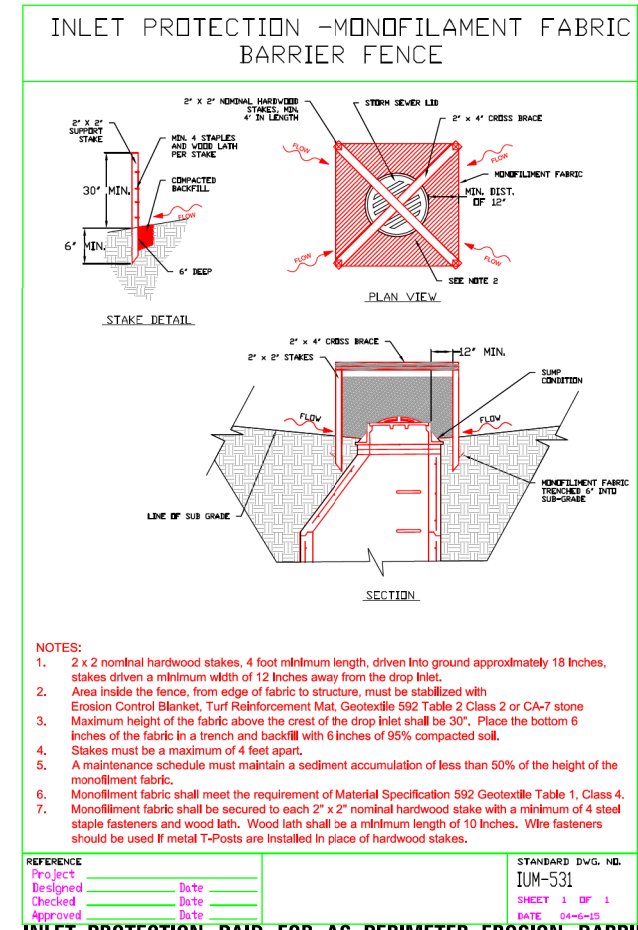

INLET PROTECTION PAID FOR AS PERIMETER EROSION BARRIER

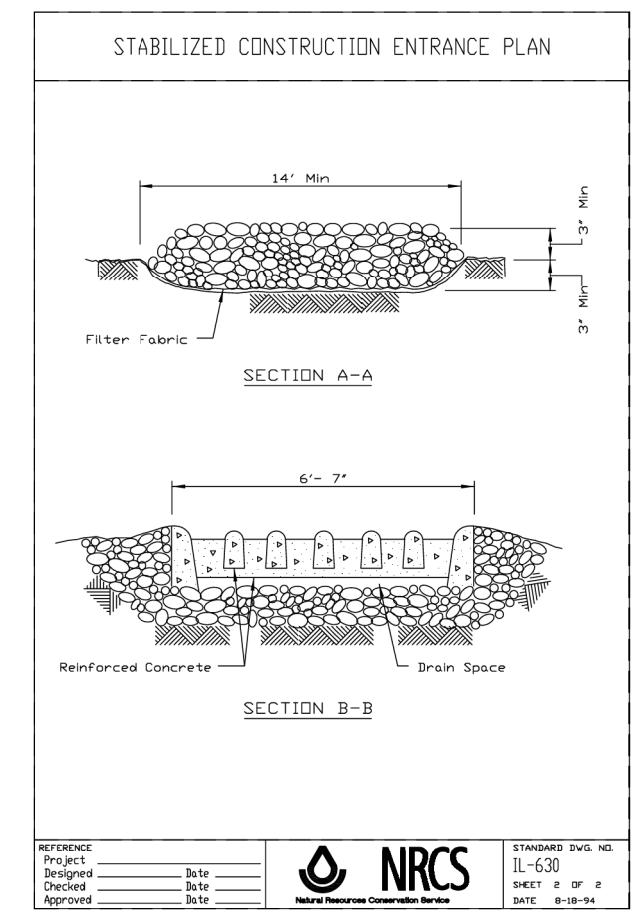

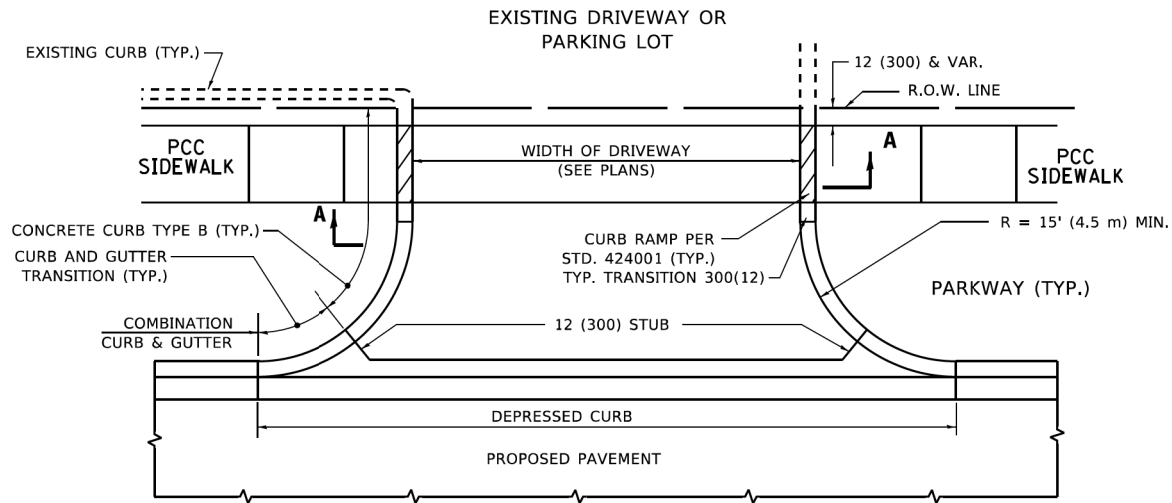

WITH CONCRETE CURB, TYPE B

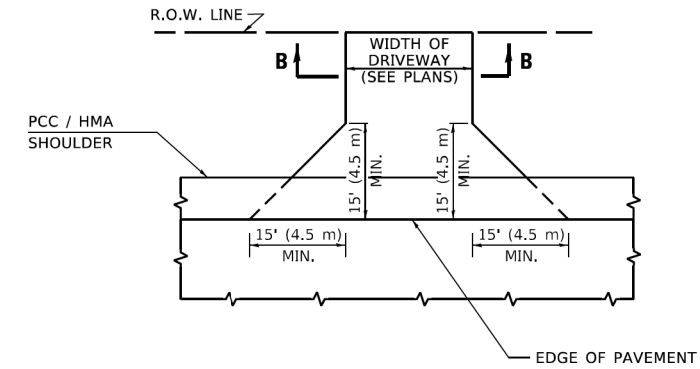

ADJACENT TO PCC /HMA SHOULDER

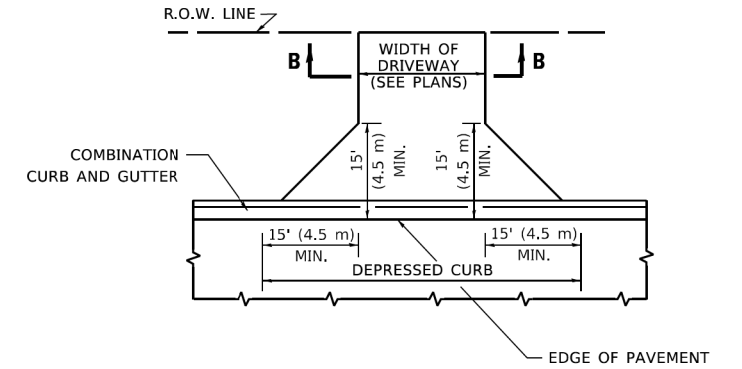

ADJACENT TO CURB AND GUTTER

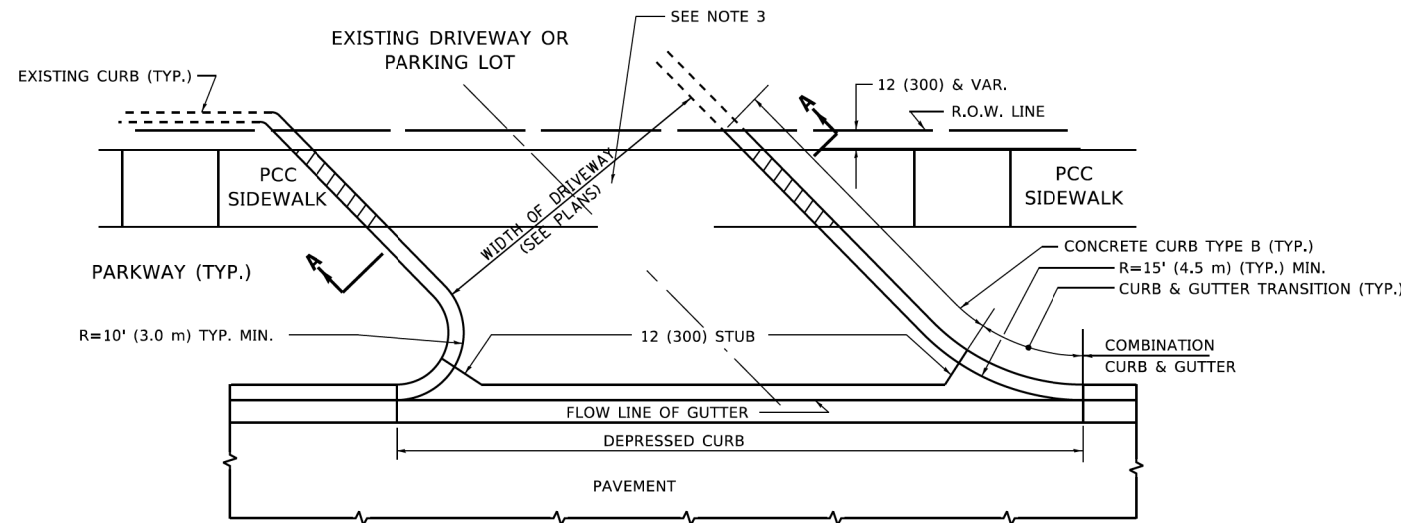

WITH CONCRETE CURB, TYPE B

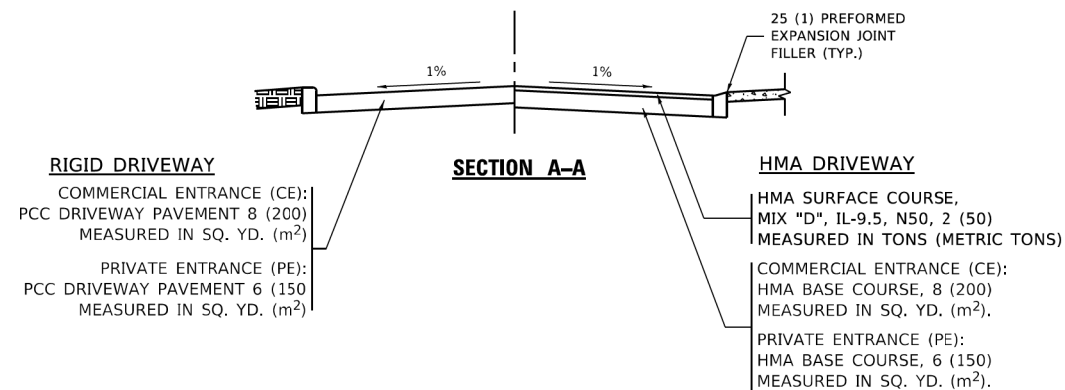
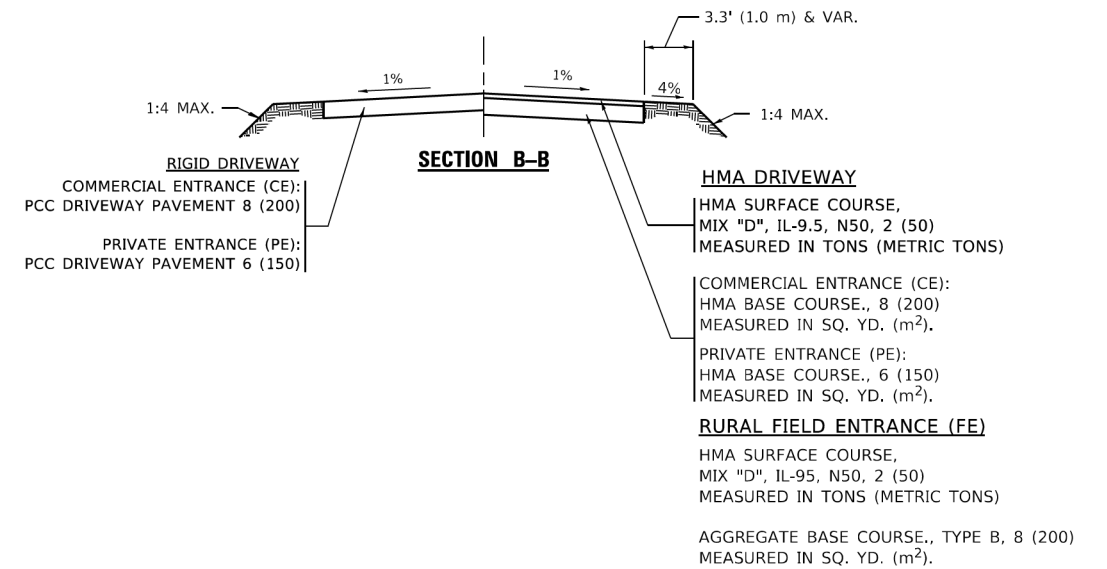

GENERAL NOTES

- DRIVEWAY SLOPES, LOCATIONS, & GEOMETRIC LAYOUT SHALL BE IN ACCORDANCE WITH THE LATEST EDITION OF THE "HANDBOOK FOR POLICY ON PERMITS FOR ACCESS DRIVEWAYS TO STATE HIGHWAYS". FOR FURTHER LAYOUT REQUIREMENTS, REFER TO ILLUSTRATIONS IN THE PERMIT HANDBOOK. DRIVEWAYS SHALL BE REPLACED IN KIND, UNLESS OTHERWISE NOTED ON THE PLANS.
- COMMERCIAL DRIVEWAYS SHALL BE CONSTRUCTED WITH CONCRETE CURB, TYPE B RETURNS EXCEPT WHEN THE SIDEWALK EDGE IS 4 FEET (1.2 METERS) OR LESS FROM THE BACK OF CURB, CONSTRUCT A FLARE DRIVEWAY WITHOUT CURB.

ALL DIMENSIONS ARE IN INCHES (MILLIMETERS) UNLESS OTHERWISE NOTED.

MODEL: Default
FILE NAME: W:\asistad\22-340b001.dgn

USER NAME = demanchelt	DESIGNED - R. SHAH	REVISED - R. BORO 06-11-08
	DRAWN -	REVISED - R. BORO 09-06-11
PLOT SCALE = 100.0000' / in.	CHECKED -	REVISED - K. SMITH 08-28-19
PLOT DATE = 2/2/2022	DATE - 11-04-95	REVISED - K. SMITH 02-01-22

**STATE OF ILLINOIS
DEPARTMENT OF TRANSPORTATION**

DRIVEWAY DETAILS - DISTANCE BETWEEN R.O.W. AND FACE OF CURB & EDGE OF SHOULDER ≥ 15'(4.5m)			
SCALE: NONE	SHEET 1 OF 1 SHEETS	STA. TO STA.	

F.A. RTE.	SECTION	COUNTY	TOTAL SHEETS	SHEET NO.
	20-00224-00-BT	COOK	89	59
BD400-01 (BD-01)			CONTRACT NO. 61J19	
ILLINOIS FED. AID PROJECT				

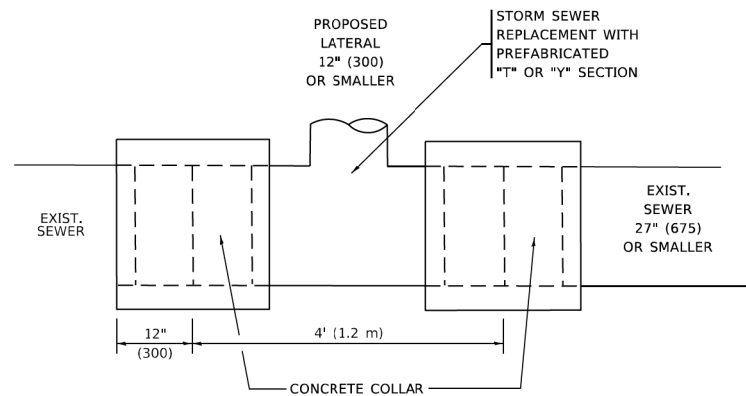

DETAIL "A"

LATERAL CONNECTION TO EXISTING SEWER OF 27" (675) OR SMALLER

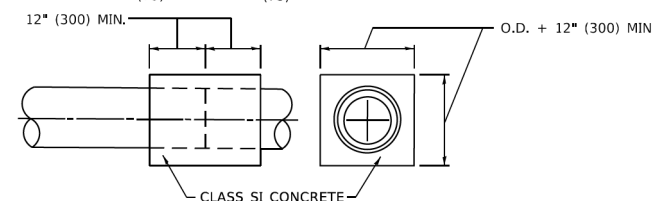
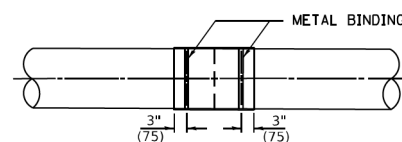
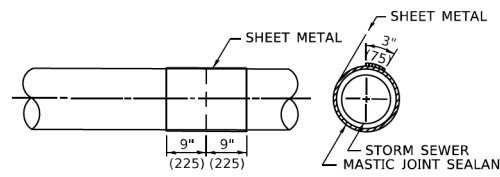
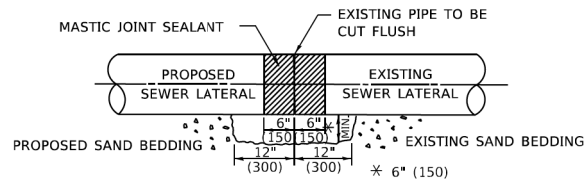

DETAIL "B"

CLASS SI CONCRETE COLLAR

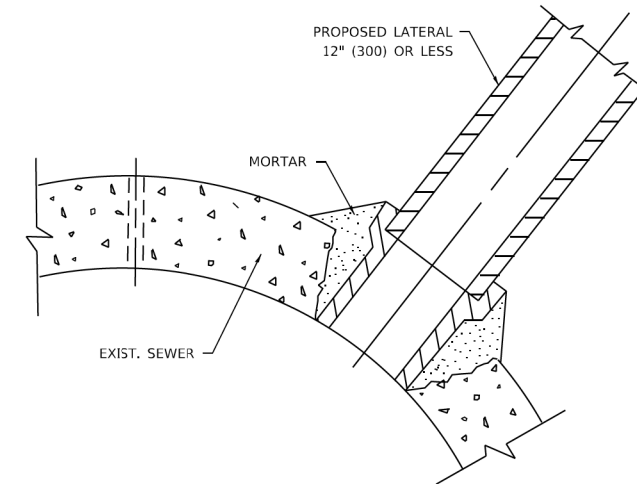

DETAIL "C"

PROPOSED LATERAL CONNECTION TO EXISTING SEWER OF 30" (750) OR LARGER

CONSTRUCTION SEQUENCE

1. CUT THE EXISTING END OF THE PIPE SO AS TO PRESENT A FLUSH BUTT JOINT. BRUSH AND CLEAN ALL PIPES.
2. APPLY THE MASTIC JOINT SEALANT TO THE FIRST 6" (150) OF EACH PIPE.
3. BUTT THE PIPES TOGETHER LEAVING A MINIMUM OF 12' x 6' (300 x 150) DEEP EXCAVATION UNDER AND AROUND EACH PIPE END.
4. CUT A PIECE OF SHEET METAL GAGE NO. 19 1.1 (0.0418) 18" (450) WIDE BY THE OUTSIDE CIRCUMFERANCE OF THE PIPE PLUS 3" (75) LONG.
5. WRAP THE SHEET METAL AROUND THE PIPES, 9" (225) ON EACH SIDE OF THE JOINT, STARTING AT THE TOP OF THE PIPE.
6. LAP THE SHEET METAL AT LEAST 3" (75) AT THE TOP OF THE PIPE AND PLACE THE MASTIC JOINT SEALANT BETWEEN THE LAP.
7. PLACE TWO METAL BANDS AROUND THE SHEET METAL AND TIGHTEN.
8. WIPE OFF ANY EXCESS MASTIC JOINT SEALANT THAT OOZES OUT FROM BETWEEN THE SHEET METAL AND THE PIPES.
9. PLACE CLASS SI CONCRETE AROUND THE JOINT.

NOTES:

MATERIAL

MATERIAL USED FOR THE TEE OR WYE SECTION SHALL BE COMPATIBLE WITH THE EXISTING STORM SEWER OR THE PROPOSED STORM SEWER.

CONSTRUCTION METHODS

- THIS WORK SHALL BE CONSTRUCTED IN CONFORMANCE WITH THE APPLICABLE PORTIONS OF SECTION 550 OF THE STANDARD SPECIFICATIONS.
- CONNECTION TO AN EXISTING STORM SEWER SHALL BE BY EITHER OF THE FOLLOWING METHODS:
 - PROPOSED STORM SEWER CONNECTION TO EXISTING SEWER OF 27" (675) OR SMALLER SEE DETAIL "A" AND "B".
 - PROPOSED STORM SEWER CONNECTION TO EXISTING SEWER OF 30" (750) OR LARGER SEE DETAIL "C".

IF THE EXISTING SEWER PIPE IS CRACKED, BROKEN OR OTHERWISE DAMAGED BY THE CONTRACTOR IN MAKING THE CIRCULAR OPENING, THE CONTRACTOR SHALL REPLACE THAT SECTION OF PIPE WITH PIPE EQUAL AND SIMILAR IN ALL RESPECTS TO THE PIPE IN THE EXISTING SEWER, IN A CAREFUL WORKMANLIKE MANNER, WITHOUT EXTRA COMPENSATION.

GENERAL

- CARE MUST BE TAKEN TO PREVENT DEBRIS FROM ENTERING THE SEWER. ALL DEBRIS WHICH ENTERS THE SEWER MUST BE REMOVED. THE SEWER MUST BE LEFT CLEAN AND UNOBSTRUCTED UPON COMPLETION OF THE CONTRACT.
- CARE MUST BE TAKEN TO PREVENT ANY PART OF THE NEW PIPE CONNECTION FROM PROJECTING INTO THE EXISTING SEWER.

BASIS OF PAYMENT

- TEE OR WYE CONNECTIONS SHALL BE PAID FOR AT THE CONTRACT UNIT PRICE EACH FOR STORM SEWER TEE OR WYE OF THE TYPE AND SIZE SPECIFIED IN THE PLANS, THIS PRICE SHALL INCLUDE ALL EXCAVATION OF THE TRENCH, REMOVAL OF THE EXISTING STORM SEWER, FURNISHING AND INSTALLING THE SPECIFIED TEE OR WYE SECTION, FURNISHING AND INSTALLING THE REQUIRED CONCRETE COLLAR, AND ALL OTHER MATERIAL NECESSARY TO COMPLETE THIS WORK AS SHOWN AND SPECIFIED.
- REMOVAL AND REINSTALLATION OF EXISTING STORM SEWER ADJACENT TO THE PROPOSED TEE OR WYE SECTION, FOR THE PURPOSE OF FACILITATING THE INSTALLATION OF THE TEE OR WYE SECTION, WILL NOT BE PAID FOR SEPARATELY BUT SHALL BE INCLUDED IN THE UNIT PRICE BID FOR THE WORK.
- TRENCH BACKFILL, EXCAVATION IN ROCK AND REMOVAL AND REPLACEMENT OF UNSUITABLE MATERIAL BELOW PLAN BEDDING GRADE WILL BE PAID FOR SEPARATELY.
- CONCRETE COLLAR FOR CONNECTING A PROPOSED STORM SEWER TO AN EXISTING STORM SEWER WILL NOT BE PAID FOR SEPARATELY BUT SHALL BE INCLUDED IN THE COST OF THE PROPOSED STORM SEWER.

* ALL DIMENSIONS ARE IN INCHES (MILLIMETERS) UNLESS OTHERWISE SHOWN.

MODEL: Detail
FILE NAME: W181510022-3-10b07.dgn

USER NAME = demanchelt	DESIGNED - M. DE YONG	REVISED - R. SHAH 09-09-94
	DRAWN -	REVISED - R. SHAH 10-25-94
PLOT SCALE = 100.0000 ' / in.	CHECKED -	REVISED - R. SHAH 06-12-96
PLOT DATE = 2/2/2022	DATE - 07-25-90	REVISED - K. SMITH 02-01-22

**STATE OF ILLINOIS
DEPARTMENT OF TRANSPORTATION**

**DETAIL OF STORM SEWER
CONNECTION TO EXISTING SEWER**

SCALE: NONE SHEET 1 OF 1 SHEETS STA. TO STA.

F.A. RTE.	SECTION	COUNTY	TOTAL SHEETS	SHEET NO.
	20-00224-00-BT	COOK	89	60
BD500-01 (BD-07)		CONTRACT NO. 61J19		
ILLINOIS FED. AID PROJECT				

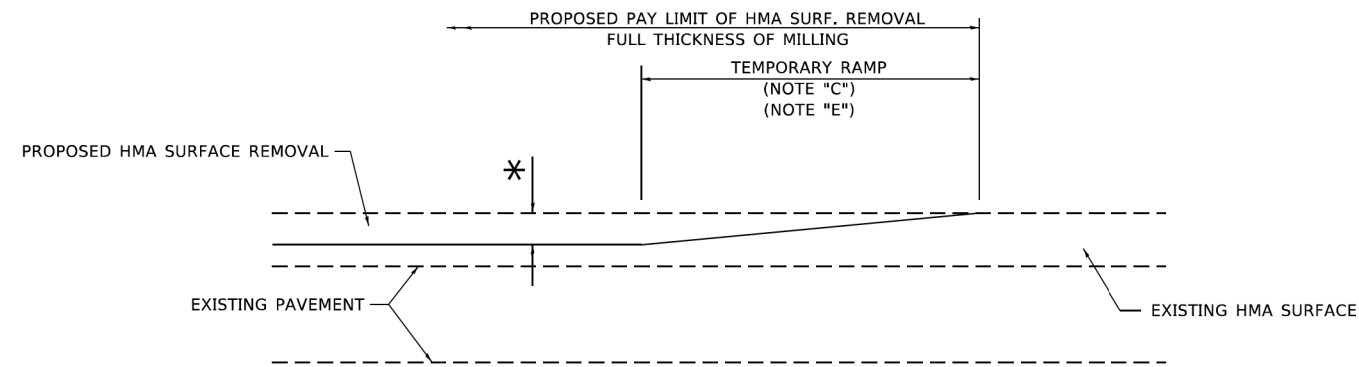

MILLED TEMPORARY RAMP

(FOR BUTT JOINT AND HMA TAPER SEE DETAIL BELOW)

OPTION 1

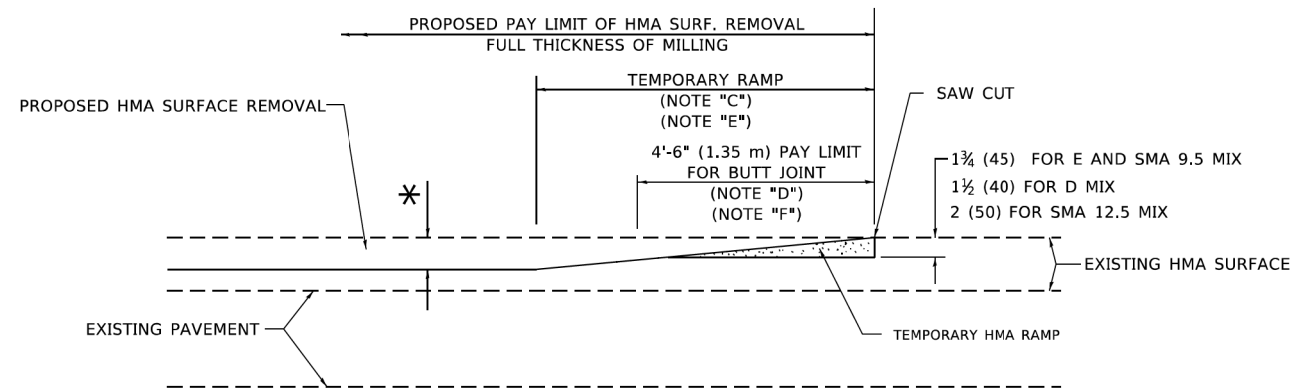

HMA CONSTRUCTED TEMPORARY RAMP

(FOR BUTT JOINT AND HMA TAPER SEE DETAIL BELOW)

OPTION 2

TYPICAL TEMPORARY RAMP

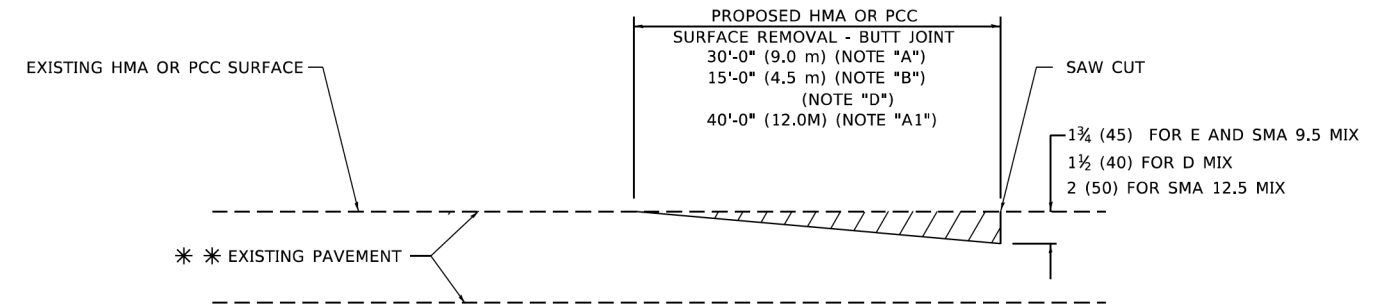

BUTT JOINT DETAIL

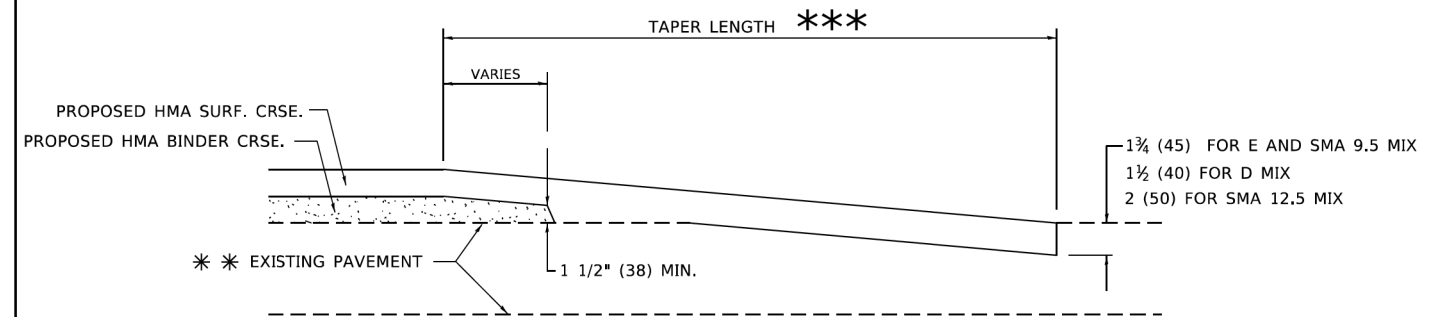

HMA TAPER DETAIL

TYPICAL BUTT JOINT AND HMA TAPER FOR RESURFACING ONLY

*** PC CONCRETE, HMA OR HMA RESURFACED PAVEMENT.

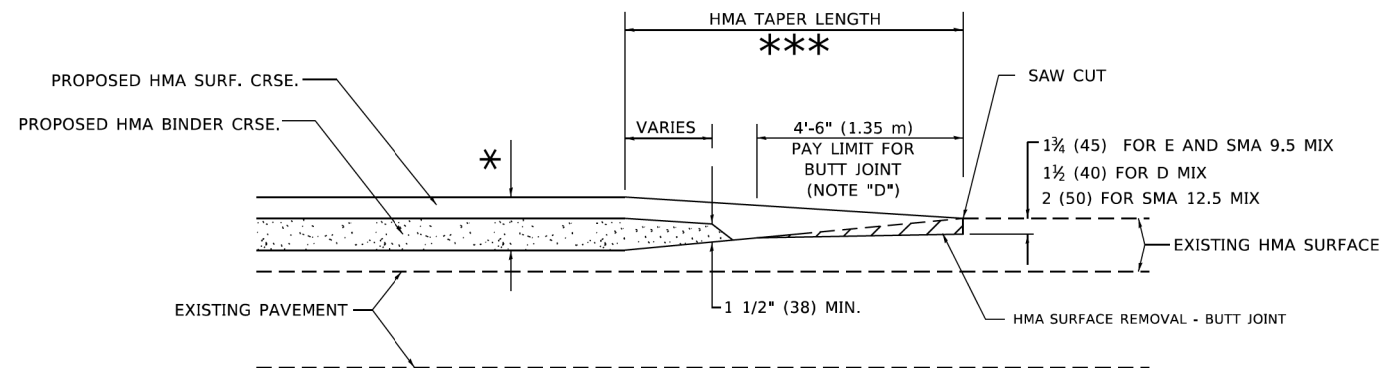

BUTT JOINT AND HMA TAPER

TYPICAL BUTT JOINT AND HMA TAPER FOR MILLING AND RESURFACING

GENERAL NOTES

- A. MAINLINE ARTERIAL ROADWAYS AND MAJOR SIDE ROADS.
- A1. INTERSTATES
- B. MINOR SIDE ROADS.
- C. THE TEMP. RAMP SHALL BE CONSTRUCTED IMMEDIATELY UPON REMOVAL OF THE EXISTING HMA SURFACE.
- D. THE BUTT JOINT SHALL BE CONSTRUCTED IMMEDIATELY PRIOR TO PLACING THE PROPOSED HMA COURSES.
- E. TAPER THE TEMP. RAMP AT A RATE OF 3' - 4" (1.02m) PER 1 INCH (25 mm) OF MILLING THICKNESS.
* SEE TYPICAL SECTIONS FOR MILLING THICKNESS.
- F. SEE ARTICLE 406.08 AND 406.14 OF THE STANDARD SPECIFICATIONS FOR "HMA AND/OR PCC SURFACE REMOVAL, BUTT JOINT".
*** 20'-0" (6.1 m) PER 1 (25) RESURFACING (NOTE "A")
10'-0" (3.0 m) PER 1 (25) RESURFACING (NOTE "B")

BASIS OF PAYMENT

- 1. THE BUTT JOINT WILL BE PAID FOR AT THE CONTRACT UNIT PRICE PER SQUARE YARD (SQUARE METER) FOR "HOT-MIX ASPHALT SURFACE REMOVAL - BUTT JOINT" OR FOR "PORTLAND CEMENT CONCRETE SURFACE REMOVAL- BUTT JOINT".
- 2. THE TEMPORARY RAMP AND SAW CUT SHALL BE INCLUDED IN THE UNIT COST FOR HMA OR PCC SURFACE REMOVAL-BUTT JOINT.

ALL DIMENSIONS ARE IN INCHES (MILLIMETERS) UNLESS OTHERWISE SHOWN.

MODEL: Default
FILE NAME: W:\Bids\22-310b32.dgn

USER NAME = demanchelt	DESIGNED - M. DE YONG	REVISED - A. ABBAS 03-21-97
	DRAWN -	REVISED - M. GOMEZ 04-06-01
PLOT SCALE = 100.0000' / in.	CHECKED -	REVISED - R. BORO 01-01-07
PLOT DATE = 2/2/2022	DATE - 06-13-90	REVISED - K. SMITH 02-01-22

STATE OF ILLINOIS
DEPARTMENT OF TRANSPORTATION

BUTT JOINT AND
HMA TAPER DETAILS

SCALE: NONE SHEET 1 OF 1 SHEETS STA. TO STA.

F.A. RTE.	SECTION	COUNTY	TOTAL SHEETS	SHEET NO.
	20-00224-00-BT	COOK	89	61
BD400-05 BD-32		CONTRACT NO. 61J19		
ILLINOIS FED. AID PROJECT				

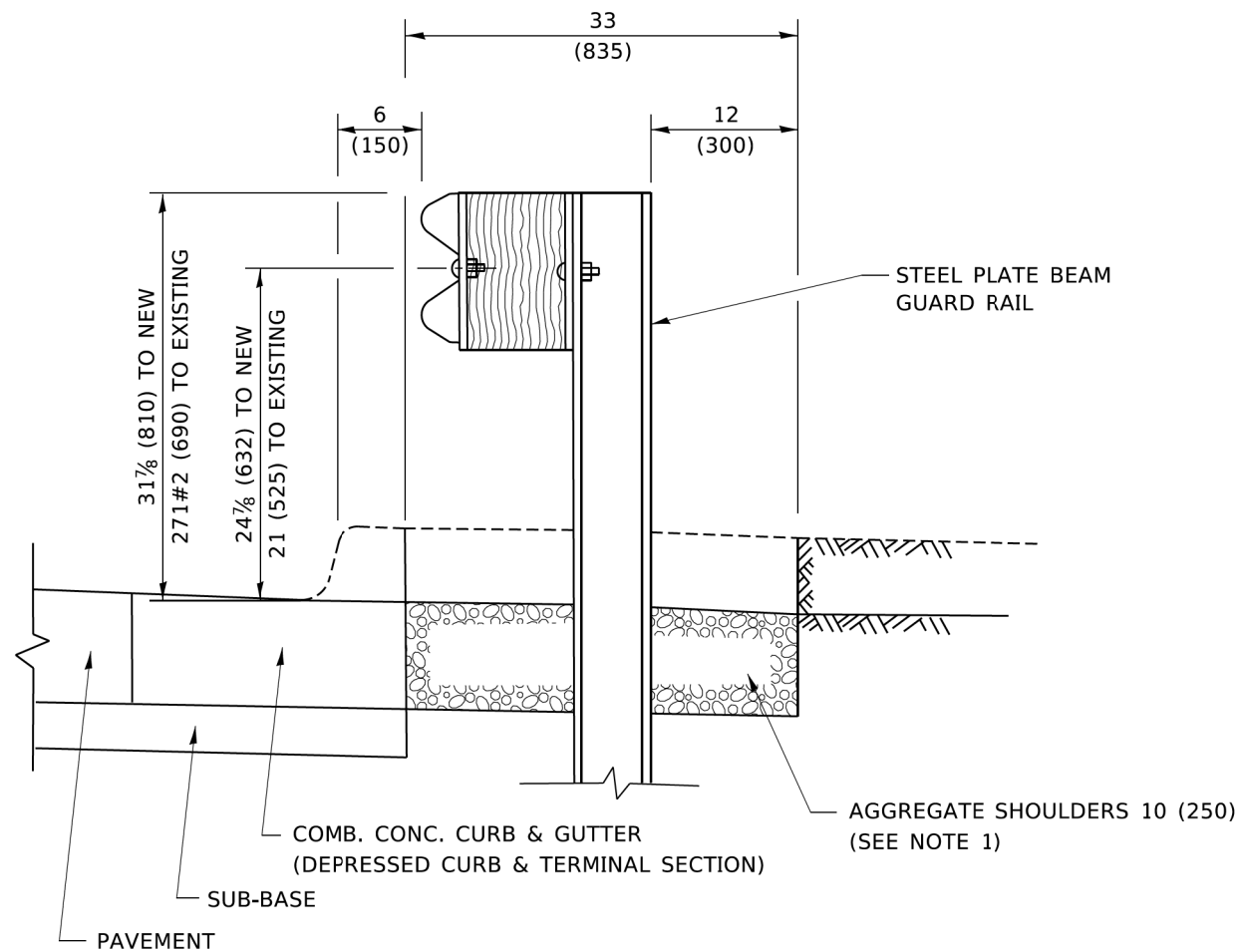

SECTION A-A

NOTES:

1. THE AGGREGATE SHOULDER, 10 (250) OR HMA SHOULDER, 6 (150) (IF REQUIRED) SHALL EXTEND UNDER THE TRAFFIC BARRIER TERMINAL.
2. "EXISTING" GUARDRAIL REFERS TO CONNECTING TERMINAL SECTION TO GUARD RAILING PRIOR TO THE MIDWEST GUARDRAIL SYSTEM.
3. THE CONTRACTOR SHALL VERIFY THE TYPE/HEIGHT OF GUARDRAIL IN-PLACE BEFORE ORDERING THE NEW TERMINAL SECTION. COST INCLUDED WITH THE COST OF THE TERMINAL. THE TERMINAL SECTION HEIGHT TO BE PLACED MUST MATCH THE HEIGHT OF THE IN-PLACE GUARDRAIL.

**DETAILS FOR STEEL PLATE BEAM
GUARD RAIL ADJACENT TO CURB AND GUTTER**

[FOR ROADWAY SPEED 35 MPH (60 kmh) TO 45 MPH (70 kmh)]

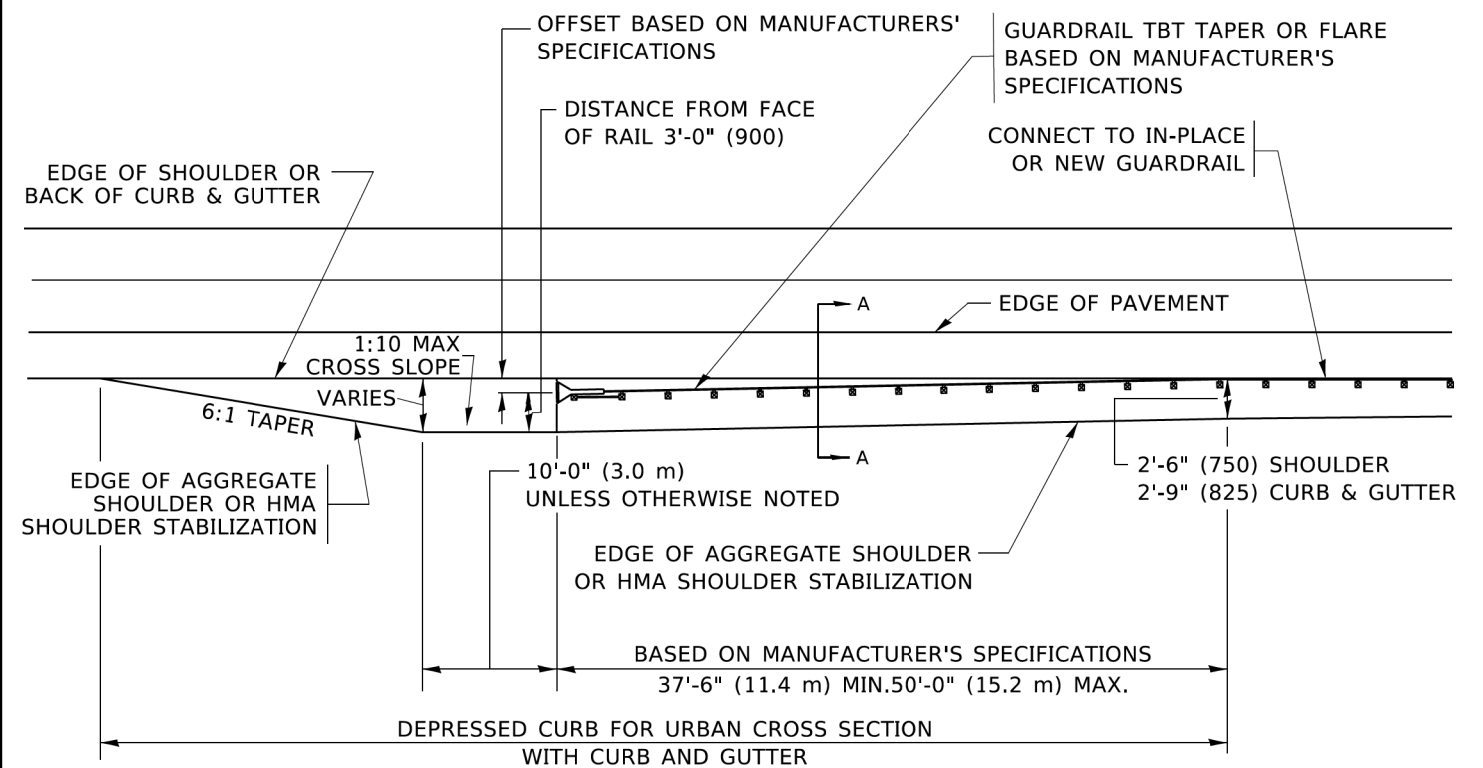

**DEPRESSED CURB AND GUTTER AND
SHOULDER TREATMENT AT TBT TY. 1 SPL.**

AGGREGATE SHOULDER, 10 (250) WILL BE PAID ACCORDING TO SECTION 481.

HMA SHOULDERS 6 (150) (IF REQUIRED) WILL BE PAID ACCORDING TO SECTION 482.

COMB. CONC. C&G, STEEL PLATE BEAM GUARD RAIL AND TRAFFIC BARRIER TERMINAL, OF THE TYPE SPECIFIED WILL BE PAID FOR SEPARATELY.

TBT = TRAFFIC BARRIER TERMINAL
ALL DIMENSIONS ARE IN INCHES (MILLIMETERS)
UNLESS OTHERWISE SHOWN.

MODEL: Default
FILE: \\miller-prod\p1\dot\Documents\DOT_Offices\District_1\Projects\DH\54272\21\CAD\Drawn\CADsheets\bd34.dgn

USER NAME = footemj	DESIGNED - M. DE YONG	REVISED - R. BORO 12-08-2008
	DRAWN -	REVISED - R. BORO 09-14-2009
PLOT SCALE = 50.0000' / in.	CHECKED -	REVISED - R. BORO 08-06-2012
PLOT DATE = 3/27/2019	DATE - 09-22-90	REVISED - R. BORO 05-08-2015

**STATE OF ILLINOIS
DEPARTMENT OF TRANSPORTATION**

**DETAILS FOR DEPRESSED CURB & GUTTER AND
SHOULDER TREATMENT AT TBT TY. 1 SPL.**

SCALE: NONE SHEET 1 OF 1 SHEETS STA. TO STA.

F.A. RTE.	SECTION	COUNTY	TOTAL SHEETS	SHEET NO.
	20-00224-00-BT	COOK	89	62
BD600-10 (BD 34)		CONTRACT NO. 61J19		
ILLINOIS FED. AID PROJECT				

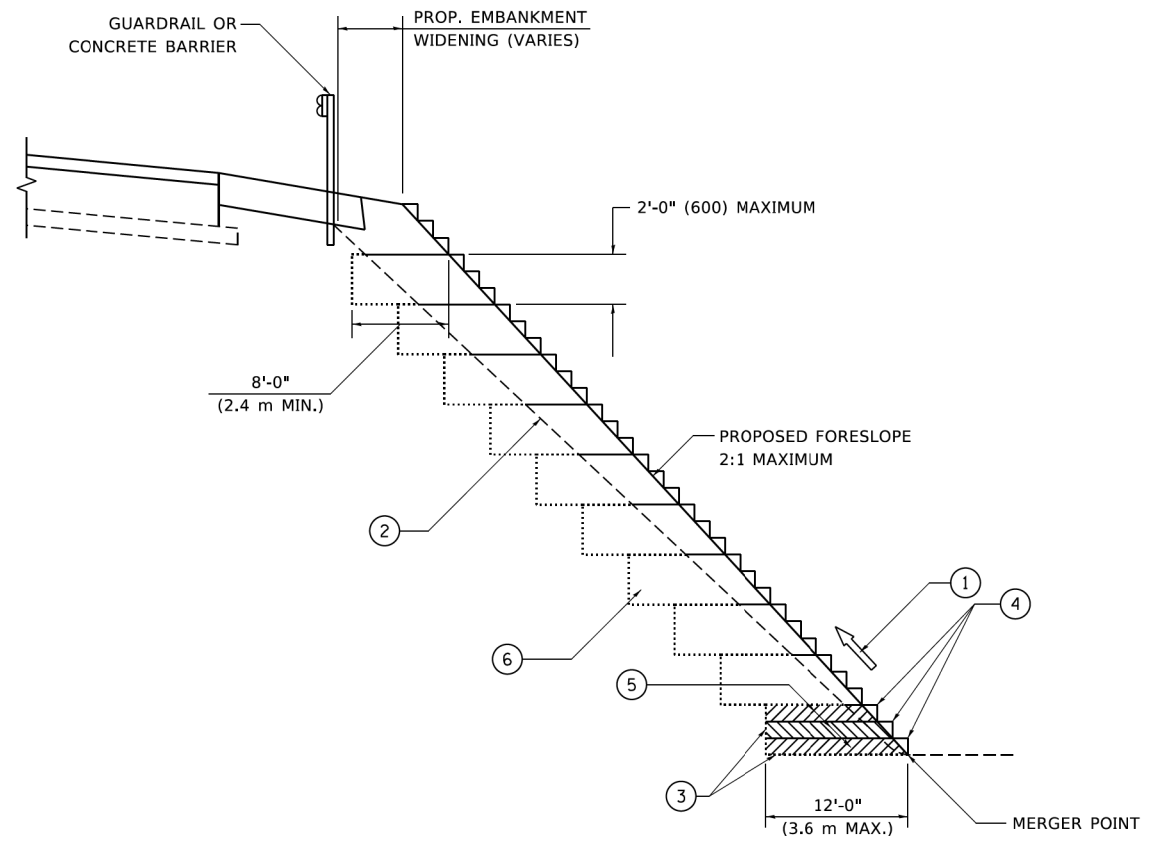

**TYPICAL BENCHING DETAIL
FOR EMBANKMENT**

NOTES:

- ① CONSTRUCT SUCCEEDING BENCH CUTS AND EMBANKMENT PLACEMENT AND COMPACTION FROM BOTTOM TO TOP IN STAIRSTEP FASHION.
- ② EXISTING FORESLOPE PREPARED IN ACCORDANCE WITH ARTICLE 205.03 OF THE STANDARD SPECIFICATIONS.
- ③ BENCH CUT EXISTING SLOPE TYPICAL FOR EACH STEP.
- ④ TRIM TO FINAL SLOPE.
- ⑤ EQUAL 8-INCH (200) LIFTS OF EMBANKMENT COMPACTED IN ACCORDANCE WITH ARTICLE 205.05 OF THE STANDARD SPECIFICATIONS.
- ⑥ EXCAVATION OF BENCH CUTS WITHIN EXISTING EMBANKMENT WILL BE PAID FOR AT THE CONTRACT UNIT PRICE PER CUBIC METER OR CUBIC YARD FOR "EARTH EXCAVATION". THIS PRICE WILL INCLUDE ALL LABOR AND MATERIAL, NO ADDITIONAL COMPENSATION WILL BE ALLOWED.
- ⑦ SLOPES SHALL BE BENCHED ACCORDING TO THIS DETAIL WHEN THE SLOPE IS STEEPER THAN 4:1 AND THE HEIGHT IS GREATER THAN 5' (1.5 m).

ALL DIMENSIONS ARE IN INCHES (MILLIMETERS)
UNLESS OTHERWISE SHOWN.

MODEL: Default
FILE: \\miller-prod\planning\com\dot_illinois.gov\PIV\DOT\Documents\DOT_Offices\District_1\Projects\DH\S272\21\CADD\ba\CADsheets\bd51.dgn

USER NAME = footemj	DESIGNED -	REVISED -
	DRAWN - CADD	REVISED -
PLOT SCALE = 50.0000' / in.	CHECKED - S.E.B.	REVISED -
PLOT DATE = 3/27/2019	DATE - 06-16-04	REVISED -

**STATE OF ILLINOIS
DEPARTMENT OF TRANSPORTATION**

**BENCHING DETAIL
FOR EMBANKMENT WIDENING**

SCALE: NONE SHEET 1 OF 1 SHEETS STA. TO STA.

F.A. RTE.	SECTION	COUNTY	TOTAL SHEETS	SHEET NO.
	20-00224-00-BT	COOK	89	63
BD-51		CONTRACT NO. 61J19		
ILLINOIS FED. AID PROJECT				

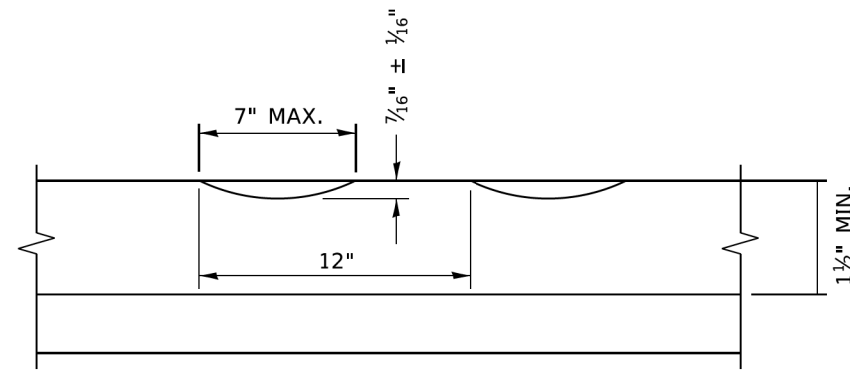

SECTION A-A

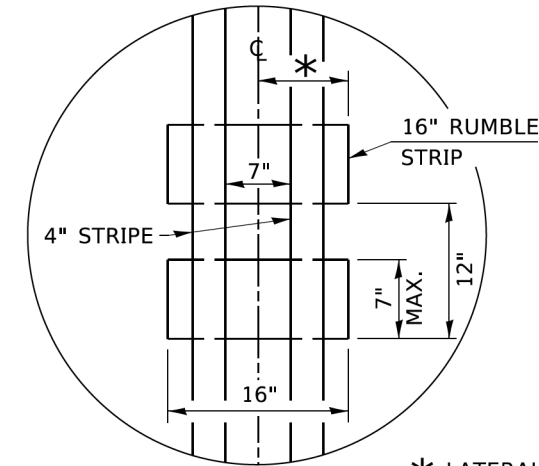

* LATERAL DEVIATION SHALL NOT EXCEED ONE INCH IN 100 FEET.

DETAIL B

GENERAL NOTES

CENTERLINE RUMBLE STRIPS SHALL BE CONSTRUCTED ACCORDING TO SECTION 642 ALONG THE CENTERLINE OF PAVEMENT.

SEE STANDARD 780001 FOR OTHER STRIPING LAYOUTS. RUMBLE STRIPS SHALL NOT BE PLACED ON BRIDGES.

ALL RUMBLE STRIPS SHALL BE MILLED.

CENTERLINE RUMBLE STRIPS SHALL BE CONTINUOUS THROUGH CONNECTIONS OF SIDEROADS WITH NO LEFT TURN LANES.

DISCONTINUE CENTERLINE RUMBLE STRIPS THROUGH THE LIMITS OF ALL LEFT TURN LANES, INCLUDING ANY LANE TAPER SECTIONS.

AFTER RUMBLE STRIPS ARE INSTALLED, THE PAVEMENT SURFACE SHALL BE SWEEPED CLEAN PRIOR TO THE PLACEMENT OF THE NEW PAVEMENT MARKINGS.

WHERE USED, ADJUST SPACING OF RAISED REFLECTIVE PAVEMENT MARKERS TO FALL IN WIDER GAP BETWEEN RUMBLE STRIPS.

BASIS OF PAYMENT

THIS WORK WILL BE PAID FOR AT THE CONTRACT UNIT PRICE PER FOOT FOR CENTERLINE-RUMBLE STRIP OF THE WIDTH SPECIFIED.

HOT-SPRAY THERMOPLASTIC PAVEMENT MARKING WILL BE USED OVER THE RUMBLE STRIPS, AND WILL BE PAID FOR SEPARATELY.

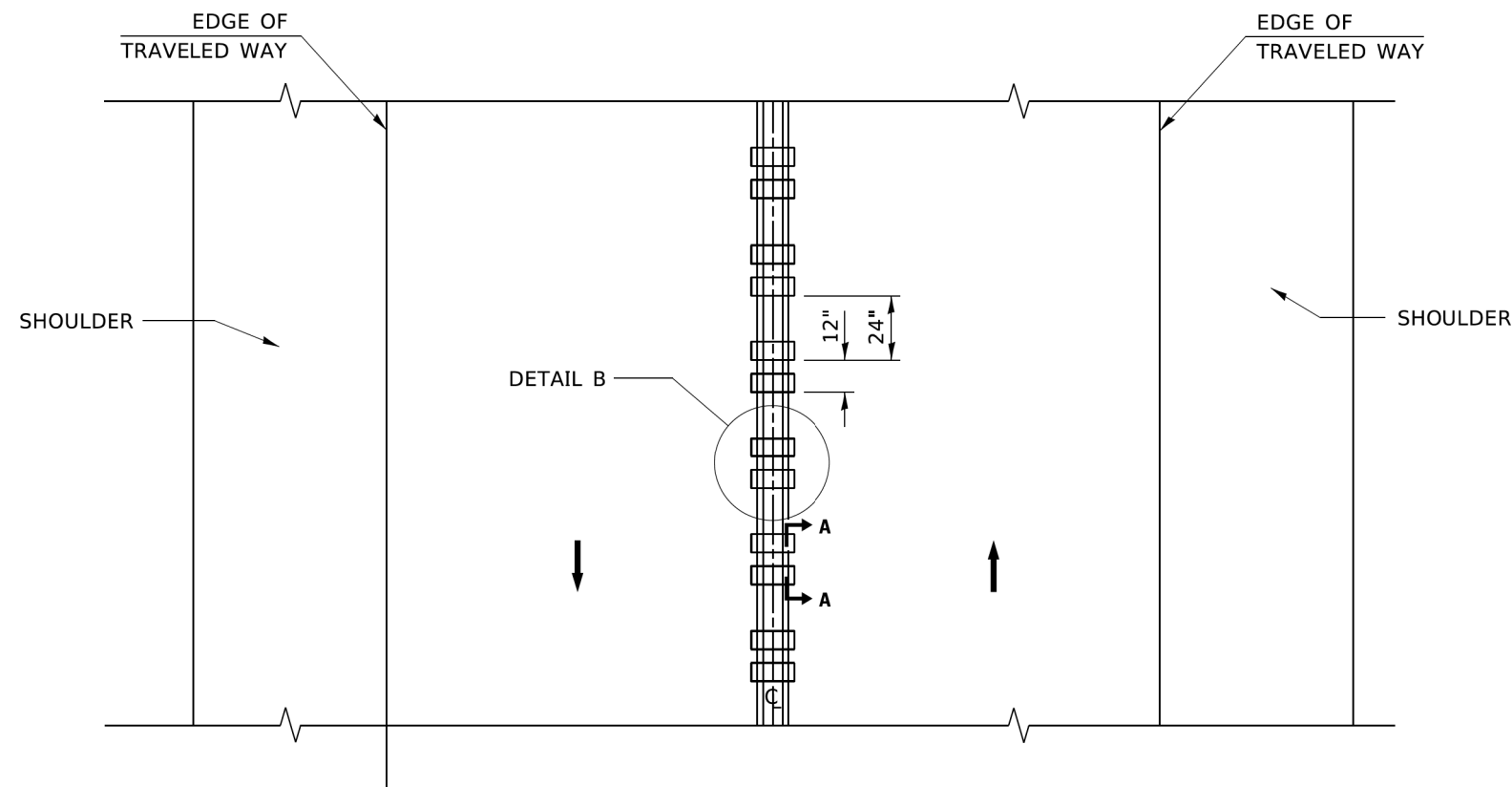

TWO-WAY ROAD

MODEL: Default
FILE: \\miller-prod\plancom\dot.illinois.gov\PIW\DOT\Documents\DOT_Offices\District_1\Projects\DH\527231\CADD\ba\CAD\sheet\1455.dgn

USER NAME = footemj	DESIGNED - R. BORO	REVISED -
	DRAWN -	REVISED -
PLOT SCALE = 50.0000' / in.	CHECKED -	REVISED -
PLOT DATE = 3/27/2019	DATE - 08-06-2012	REVISED -

**STATE OF ILLINOIS
DEPARTMENT OF TRANSPORTATION**

RUMBLE STRIPS FOR CENTERLINE, NON-FREEWAY

SCALE: NONE SHEET 1 OF 1 SHEETS STA. TO STA.

F.A. RTE.	SECTION	COUNTY	TOTAL SHEETS	SHEET NO.
	20-00224-00-BT	COOK	89	64
BD 55			CONTRACT NO. 61J19	
ILLINOIS FED. AID PROJECT				

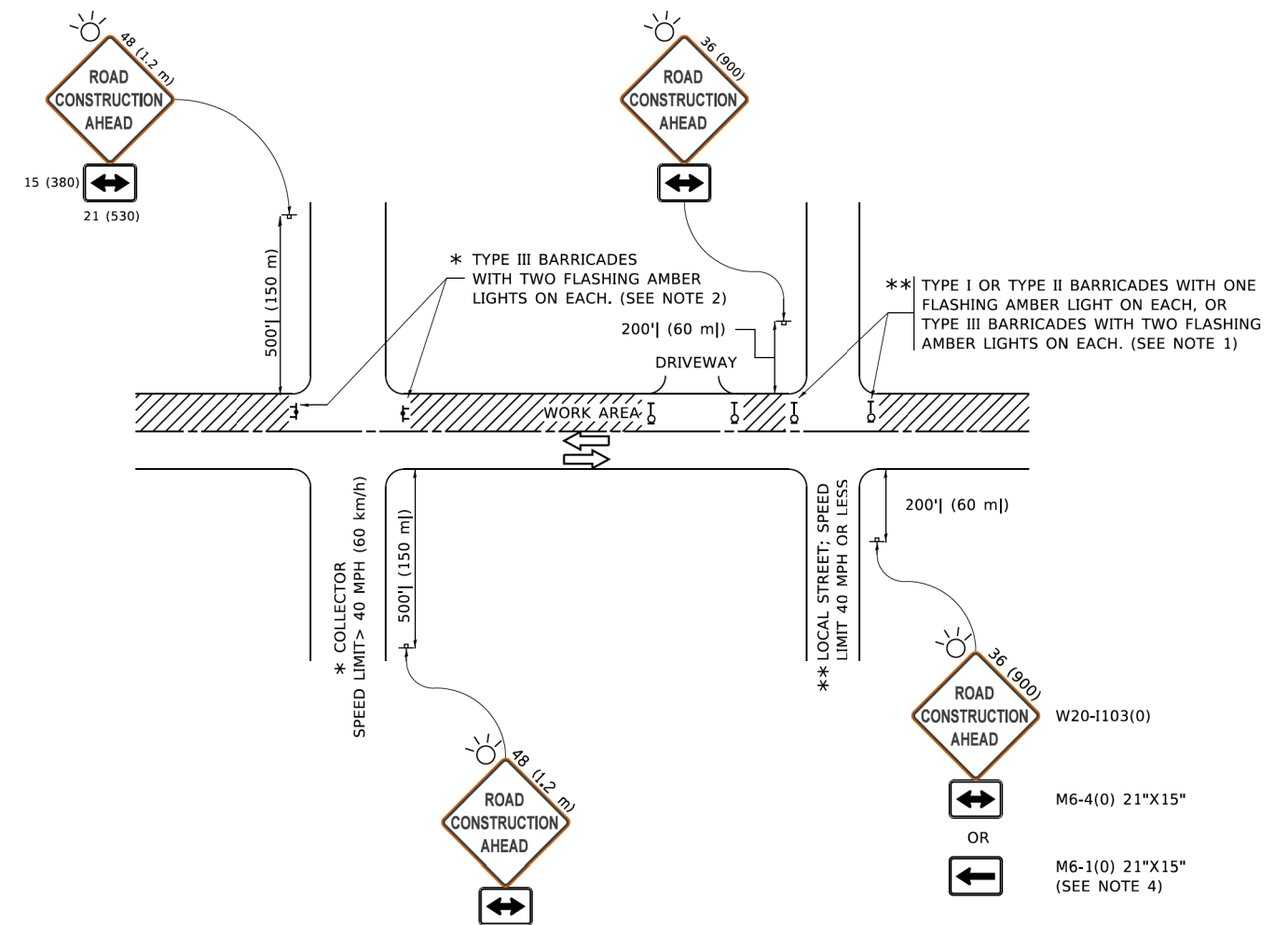

NOTES:

- SIDE ROAD WITH A SPEED LIMIT OF 40 MPH (60 km/h) OR LESS AS SHOWN ON THE DRAWING AND AS DIRECTED BY THE ENGINEER:
 - ONE "ROAD CONSTRUCTION AHEAD" SIGN 36 x 36 (900x900) WITH A FLASHER MOUNTED ON IT APPROXIMATELY 200' (60 m) IN ADVANCE OF THE MAIN ROUTE.
 - THE CLOSED PORTION OF THE MAIN ROUTE SHALL BE PROTECTED BY BLOCKING WITH TYPE I, TYPE II OR TYPE III BARRICADES, 1/3 OF THE CROSS SECTION OF THE CLOSED PORTION.
- SIDE ROAD WITH A SPEED LIMIT GREATER THAN 40 MPH (60 km/h) AS SHOWN ON THE DRAWING AND AS DIRECTED BY THE ENGINEER:
 - ONE "ROAD CONSTRUCTION AHEAD" SIGN 48 x 48 (1.2 m x 1.2 m) WITH A FLASHER MOUNTED ON IT APPROXIMATELY 500' (150 m) IN ADVANCE OF THE MAIN ROUTE.
 - THE CLOSED PORTION OF THE MAIN ROUTE SHALL BE PROTECTED BY BLOCKING WITH TYPE III BARRICADES, 1/2 OF THE CROSS SECTION OF THE CLOSED PORTION.
- CONES MAY BE SUBSTITUTED FOR BARRICADES OR DRUMS AT HALF THE SPACING DURING DAY OPERATIONS. CONES SHALL BE A MINIMUM OF 28 (710) IN HEIGHT.
- WHEN THE SIDE ROAD LIES BETWEEN THE BEGINNING OF THE MAINLINE SIGNING AND THE WORK ZONE, A SINGLE HEADED ARROW (M6-1) SHALL BE USED IN LIEU OF THE DOUBLE HEADED ARROW (M6-4).
- WHEN WORK IS BEING PERFORMED ON A SIDE ROAD OR DRIVEWAY, FOLLOW THE APPLICABLE STANDARD(S). THE DIRECTIONAL ARROW (M6-1 OR M6-4) SHALL BE COVERED OR REMOVED WHEN NO LONGER CONSISTENT WITH THE TRAFFIC CONTROL SET-UP.
- ADVANCE WARNING SIGNS ARE TO BE OMITTED ON DRIVEWAYS UNLESS OTHERWISE SPECIFIED IN THE PLANS OR BY THE ENGINEER.
- THE TRAFFIC CONTROL AND PROTECTION FOR SIDE ROADS, INTERSECTIONS, AND DRIVEWAYS SHALL BE INCLUDED IN THE COST OF SPECIFIED TRAFFIC CONTROL STANDARDS OR ITEMS.

All dimensions are in inches (millimeters) unless otherwise shown.

MODEL: Default
FILE NAME: P:\110847EB\BENTEGE\Illinois.gov\PIV\DOT\Documents\DOT_Offices\Dist\ctc_1\Projects\Dist\5273-21\CADD\Dist\CAD\Sheet\ctc1.dgn

USER NAME = footej	DESIGNED - L.H.A.	REVISED - A. HOUSEH 10-15-96
	DRAWN -	REVISED - T. RAMMACHER 01-06-00
PLOT SCALE = 50.0000' / in.	CHECKED -	REVISED - A. SCHUETZE 07-01-13
PLOT DATE = 3/4/2019	DATE - 06-89	REVISED - A. SCHUETZE 09-15-16

**STATE OF ILLINOIS
DEPARTMENT OF TRANSPORTATION**

**TRAFFIC CONTROL AND PROTECTION FOR
SIDE ROADS, INTERSECTIONS, AND DRIVEWAYS**

SCALE: NONE SHEET 1 OF 1 SHEETS STA. TO STA.

F.A. RTE.	SECTION	COUNTY	TOTAL SHEETS	SHEET NO.
	20-00224-00-BT	COOK	89	65
TC-10			CONTRACT NO. 61J19	
ILLINOIS FED. AID PROJECT				

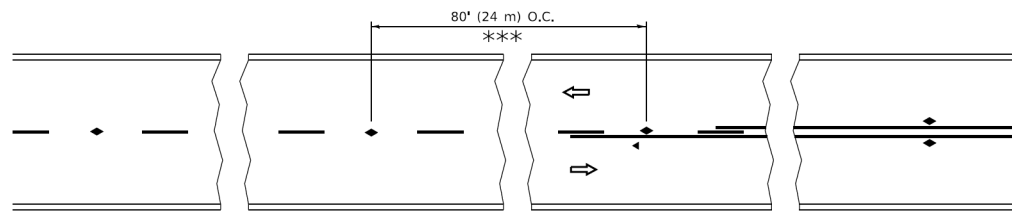

*** REDUCE TO 40' (12 m) O.C. ON CURVES WITH POSTED OR ADVISORY SPEED 45 M.P.H. (70 km/h) OR LESS.

TWO-LANE/TWO-WAY

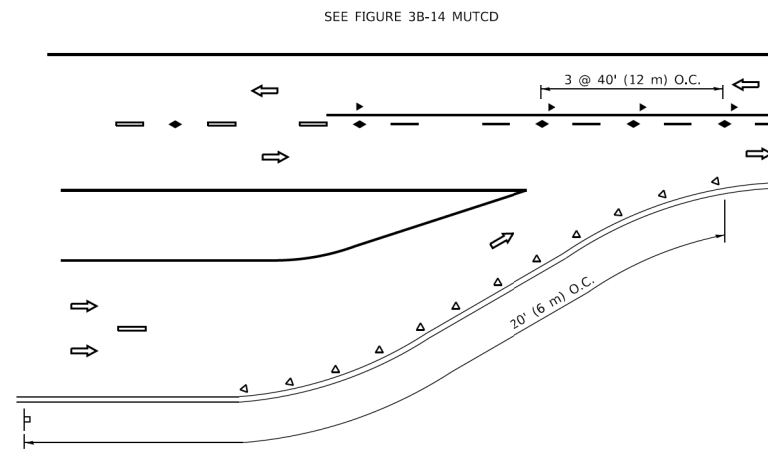

LANE REDUCTION TRANSITION

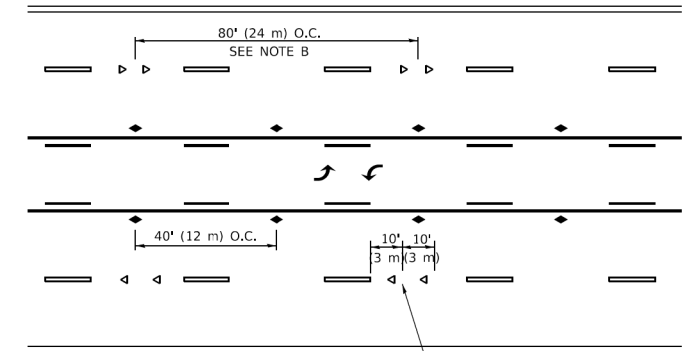

TWO-WAY LEFT TURN

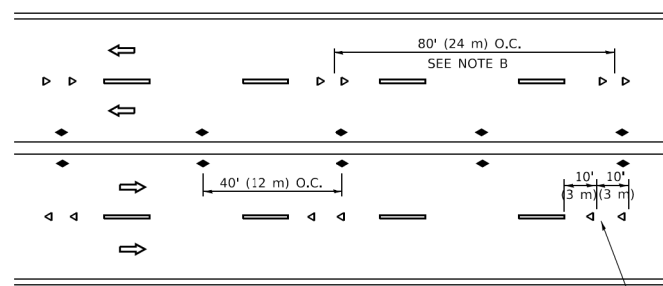

MULTI-LANE/UNDIVIDED

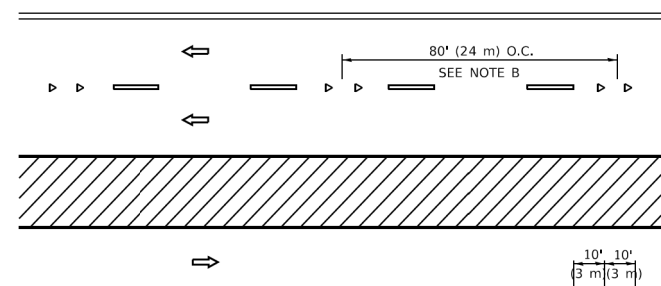

MULTI-LANE/DIVIDED

GENERAL NOTES

1. MARKERS USED WITH DASHED LINES SHALL BE CENTERED IN THE GAP BETWEEN SEGMENTS.
2. MARKERS USED ADJACENT TO SOLID LINES SHALL BE OFFSET 2 TO 3 (50 TO 75) TOWARD TRAFFIC AS SHOWN.
3. MARKERS THROUGH TANGENTS LESS THAN 500' (150 m) IN LENGTH BETWEEN CURVES SHALL BE INSTALLED AT THE LESSER OF THE TWO CURVE SPACINGS.
4. MARKERS ARE TO BE USED ADJACENT TO BOTH SOLID WHITE LINES IN DUAL LEFT TURN LANES

SYMBOLS

- YELLOW STRIPE
- WHITE STRIPE
- ◀ ONE-WAY AMBER MARKER
- ◀ ONE-WAY CRYSTAL MARKER (W/O)
- ◆ TWO-WAY AMBER MARKER

LANE MARKER NOTES

- A. USE DOUBLE LANE LINE MARKERS SPACED AS SHOWN.
- B. REDUCE TO 40' (12 m) O.C. ON CURVES WHERE ADVISORY SPEEDS ARE 10 M.P.H (20 km/h) LOWER THAN POSTED SPEEDS.

DESIGN NOTES

1. DOUBLE LANE LINE MARKERS SHALL BE USED UNLESS SPECIFIED OTHERWISE.
2. EXCEPT AS SHOWN ON THE LANE REDUCTION TRANSITION AND FREEWAY EXIT RAMP DETAIL, MARKERS ARE NOT TO BE SPECIFIED ON RIGHT EDGE LINES.
3. THE EXACT MARKER LIMITS, SPACING, AND COLOR SHALL BE INCLUDED IN THE PLANS WHEN STANDARD SPECIFICATIONS ARE NOT BEING USED.
4. MARKERS SHOULD NOT BE USED ALONGSIDE CURBS EXCEPT FOR EXTREMELY SHORT SECTIONS OF CURBS WHERE NOT MORE THAN TWO MARKERS WOULD BE INVOLVED.

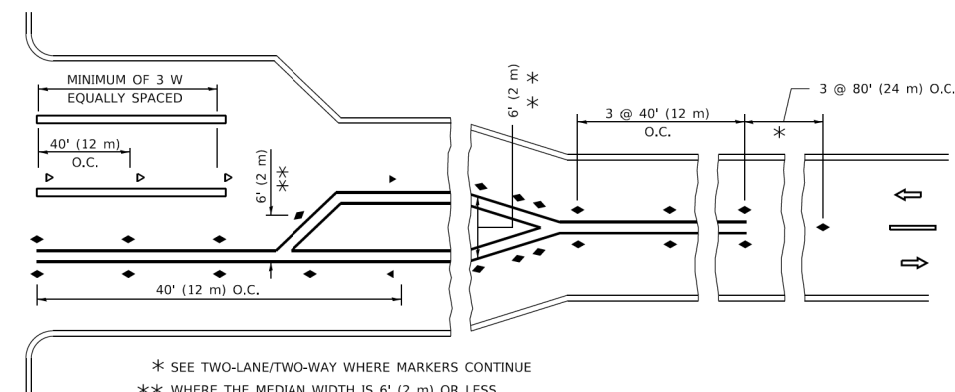
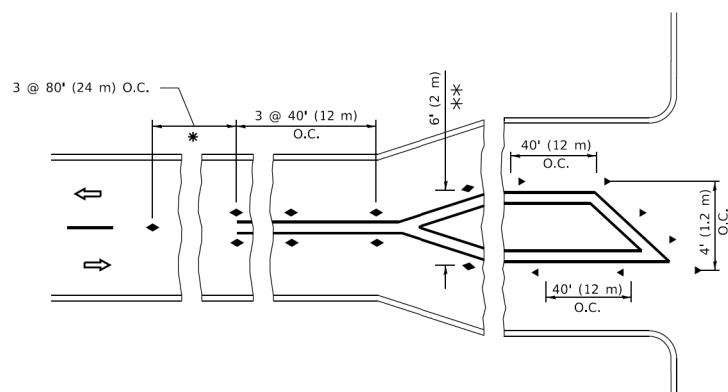

TURN LANES

* SEE TWO-LANE/TWO-WAY WHERE MARKERS CONTINUE
 ** WHERE THE MEDIAN WIDTH IS 6' (2 m) OR LESS USE TWO-WAY MARKERS.

All dimensions are in inches (millimeters) unless otherwise shown.

MODEL: Default
 FILE: \\miller.pwll084\FED\INTEG\Illinois.gov\PIV\DOT\Documents\DOT Offices\District 1\Projects\Dist5\273-24\CADD\Plan\CAD\Sheet\11.dgn

USER NAME = footemj	DESIGNED -	REVISED - T. RAMMACHER 03-12-99
	DRAWN -	REVISED - T. RAMMACHER 01-06-00
PLOT SCALE = 50.0000' / in.	CHECKED -	REVISED - C. JUCIUS 09-09-09
PLOT DATE = 3/4/2019	DATE -	REVISED - C. JUCIUS 07-01-13

**STATE OF ILLINOIS
 DEPARTMENT OF TRANSPORTATION**

TYPICAL APPLICATIONS			
RAISED REFLECTIVE PAVEMENT MARKERS (SNOW-PLOW RESISTANT)			
SCALE: NONE	SHEET 1	OF 1 SHEETS	STA. TO STA.

F.A. RTE.	SECTION	COUNTY	TOTAL SHEETS	SHEET NO.
	20-00224-00-BT	COOK	89	66
TC-11		CONTRACT NO. 61J19		
ILLINOIS FED. AID PROJECT				

TURN BAY ENTRANCE AT START OF LANE CLOSURE TAPER

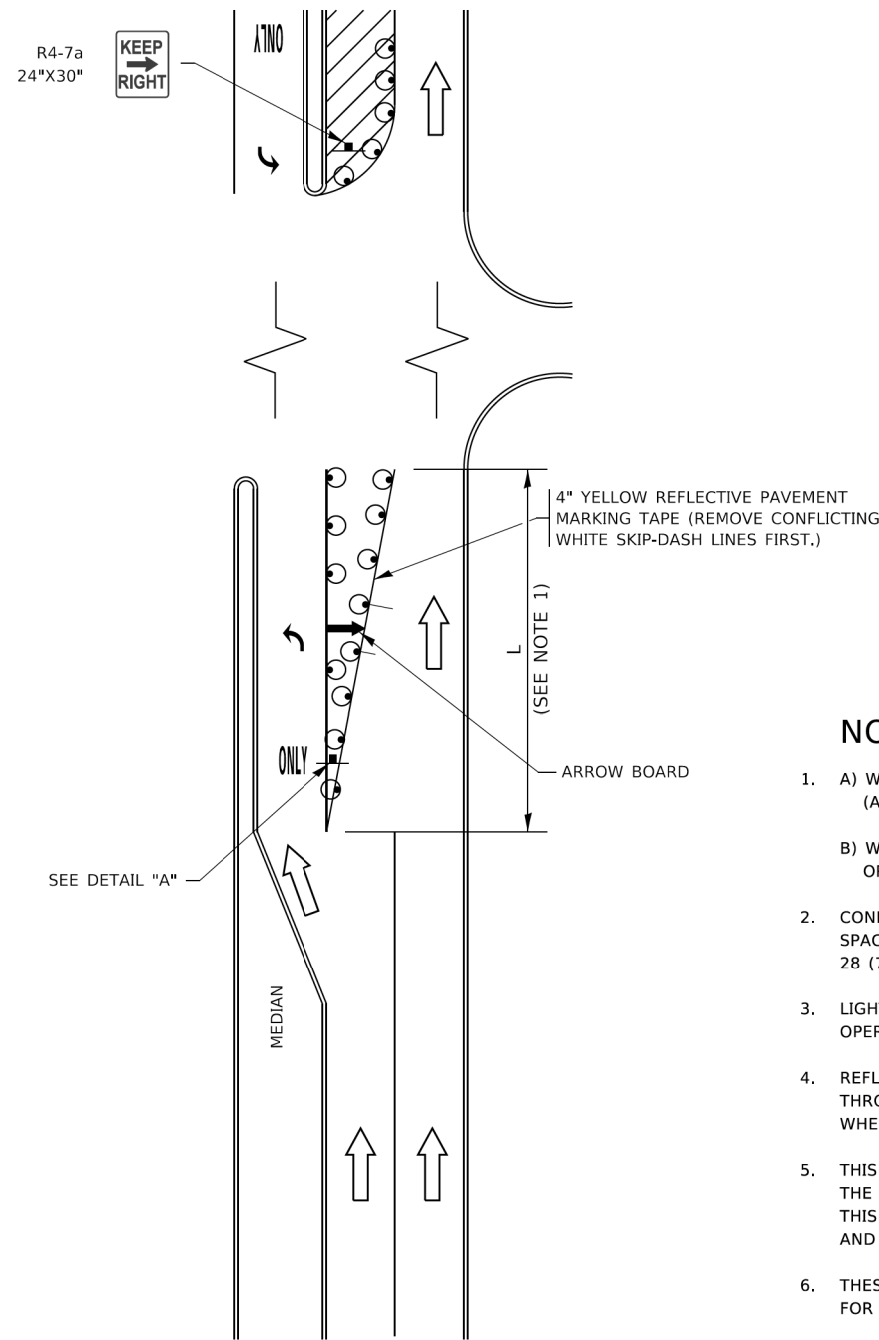

FIGURE 1

TURN BAY ENTRANCE WITHIN A LANE CLOSURE

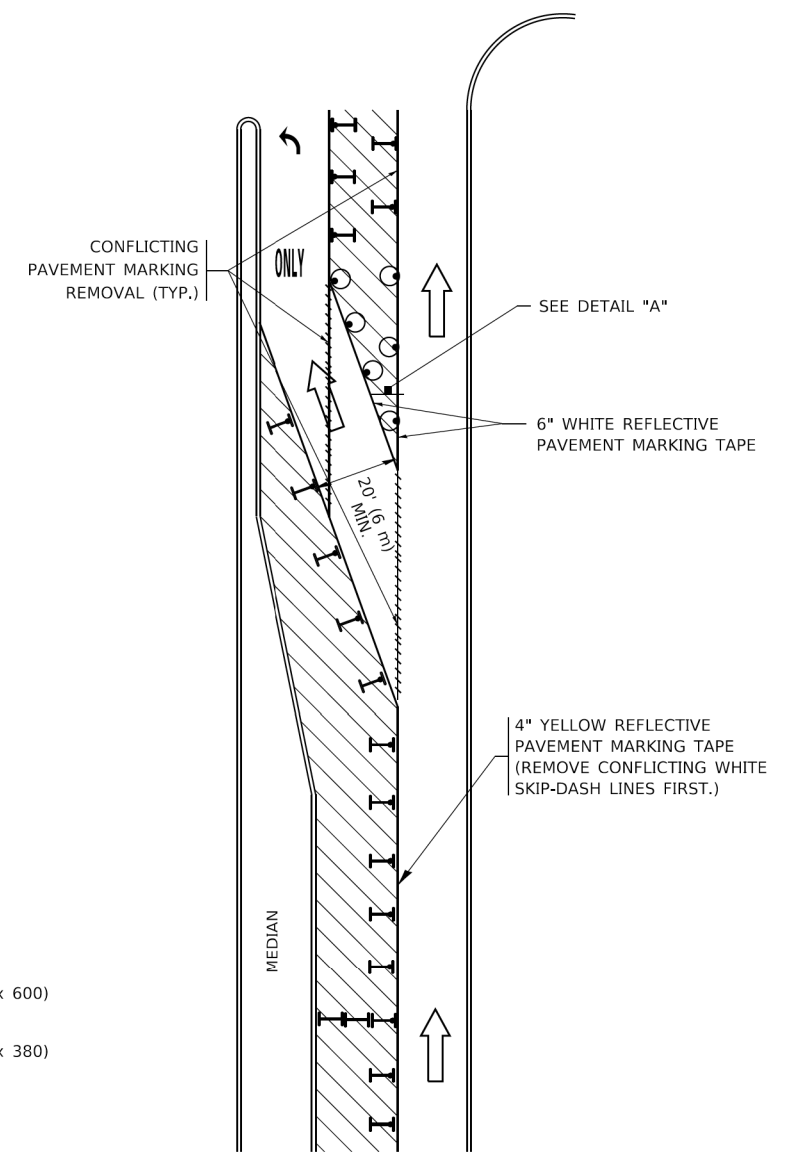

FIGURE 2

LEGEND

- WORK AREA
- LANE OPEN TO TRAFFIC
- ARROW BOARD
- TYPE I OR II BARRICADE OR DRUM WITH STEADY BURN LIGHT
- DRUM WITH STEADY BURN LIGHT
- SIGN ASSEMBLY
- TYPE I OR II CHECK BARRICADE WITH FLASHING LIGHT

NOTES:

1. A) WHEN "L" IS ≤ THE STORAGE LENGTH OF THE TURN LANE (AS SHOWN IN FIG. 1), USE FIGURE 1.
B) WHEN "L" IS > THE STORAGE LENGTH OF THE TURN LANE OR THE TURN LANE IS WITHIN THE LANE CLOSURE, USE FIGURE 2.
2. CONES MAY BE SUBSTITUTED FOR BARRICADES OR DRUMS AT HALF THE SPACING DURING DAY OPERATIONS. CONES SHALL BE A MINIMUM OF 28 (710) IN HEIGHT.
3. LIGHTS WILL NOT BE REQUIRED ON BARRICADES OR DRUMS FOR DAY OPERATIONS. ALL LIGHTS SHALL BE MONODIRECTIONAL.
4. REFLECTIVE TEMPORARY PAVEMENT MARKINGS SHALL BE PLACED THROUGHOUT THE BARRICADED AREAS OF EACH TURN BAY AS SHOWN WHERE THE CLOSURE TIME IS GREATER THAN FOURTEEN (14) DAYS.
5. THIS APPLICATION ALSO APPLIES WHEN WORK IS BEING PERFORMED IN THE RIGHT LANE(S) AND THE RIGHT TURN BAY IS TO REMAIN OPEN. UNDER THIS CONDITION, "RIGHT TURN LANE" R3-1100R 24 x 24 (600 x 600) AND M6-2R 21 x 15 (530 x 380) SHALL BE USED.
6. THESE CONTROLS SHALL SUPPLEMENT MAINLINE TRAFFIC CONTROL FOR LANE CLOSURES.
7. THE SIGNS SHALL BE MOUNTED ABOVE THE BARRICADES/DRUMS ON SEPARATE SIGN SUPPORTS THAT MEET NCHRP 350 OR MASH REQUIREMENTS.
8. TRAFFIC CONTROL AND PROTECTION AT TURN BAYS (TO REMAIN OPEN TO TRAFFIC) SHALL BE INCLUDED IN THE COST OF SPECIFIED TRAFFIC CONTROL STANDARDS OR ITEMS.

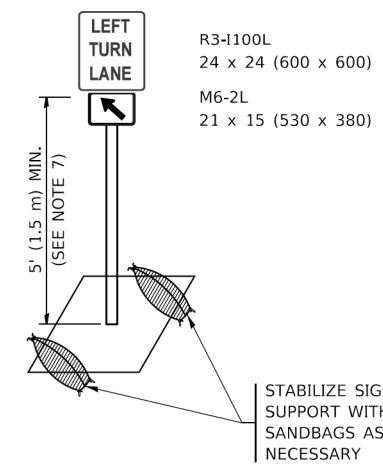

DETAIL A

All dimensions are in inches (millimeters) unless otherwise shown.

MODEL: Default; FILE: \\m1010848\BENTNET\EG\Illinois\gov\PIV\DOT\Documents\DOT_Offices\District_1\Projects\Dist1\2022\2022-CAD\DATA\CAD\Sheet\14.dgn

USER NAME = footemj	DESIGNED - T. RAMMACHER 09-08-94	REVISED - R. BORO 09-14-09
	DRAWN - A. HOUSEH 11-07-95	REVISED - A. SCHUETZE 07-01-13
PLOT SCALE = 50.0000' / in.	CHECKED - A. HOUSEH 10-12-96	REVISED - A. SCHUETZE 09-15-16
PLOT DATE = 3/4/2019	DATE - T. RAMMACHER 01-06-00	REVISED -

**STATE OF ILLINOIS
DEPARTMENT OF TRANSPORTATION**

**TRAFFIC CONTROL AND PROTECTION AT TURN BAYS
(TO REMAIN OPEN TO TRAFFIC)**

SCALE: NONE SHEET 1 OF 1 SHEETS STA. TO STA.

F.A. RTE.	SECTION	COUNTY	TOTAL SHEETS	SHEET NO.
	20-00224-00-BT	COOK	89	68
TC-14		CONTRACT NO. 61J19		
ILLINOIS FED. AID PROJECT				

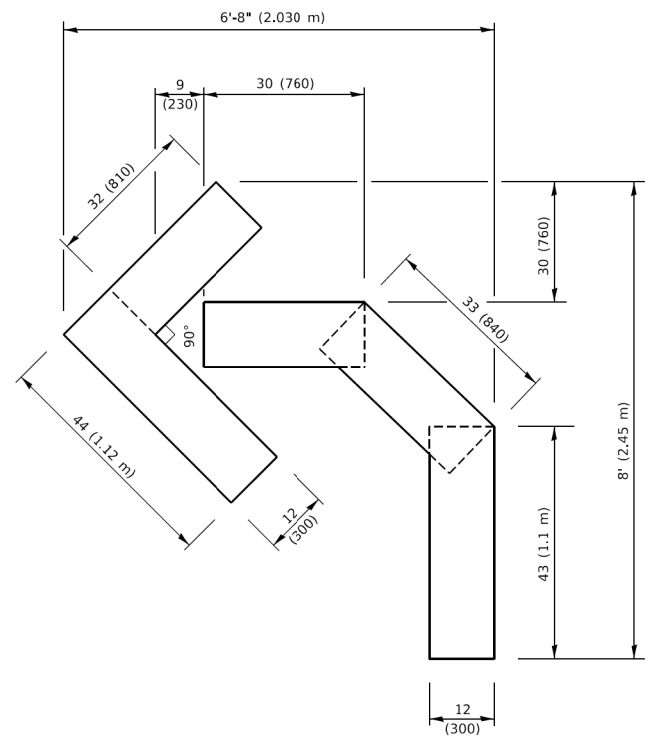

QUANTITY

4 (100) LINE = 45.5 ft. (13.9 m)
15.2 sq. ft. (1.41 sq. m)

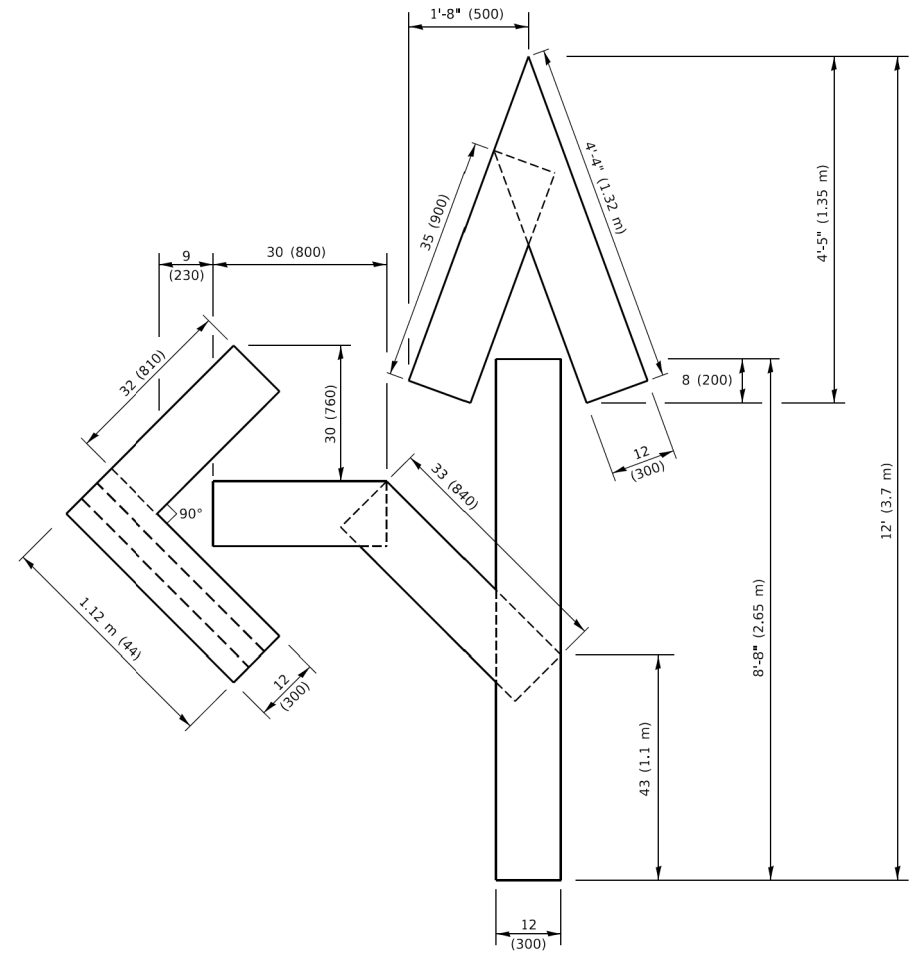

QUANTITY

4 (100) LINE = 82.5 ft. (25.1 m)
27.5 sq. ft. (2.53 sq. m)

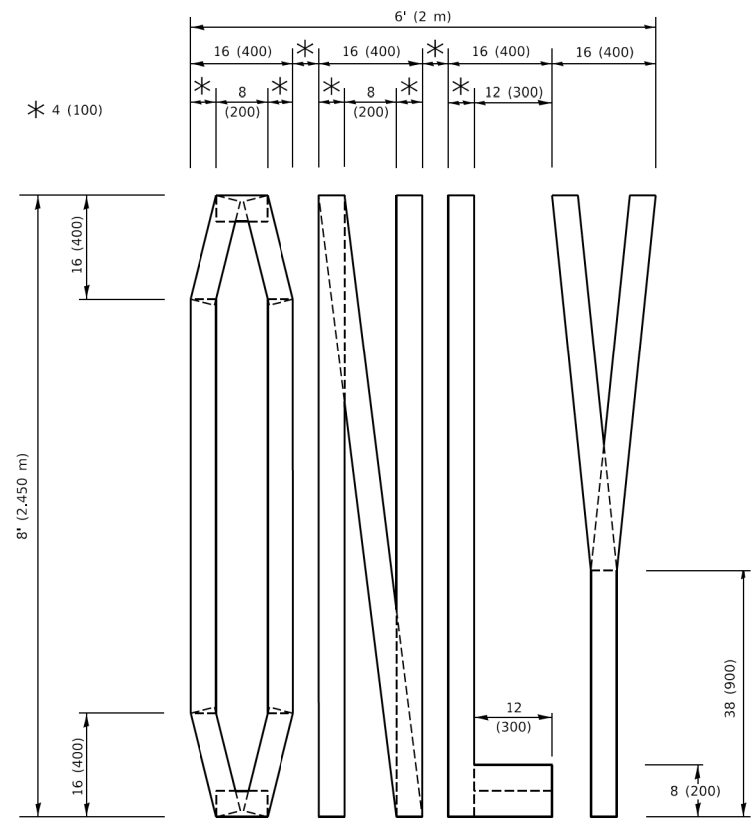

QUANTITY

4 (100) LINE = 64.1 ft. (19.5 m)
21.4 sq. ft. (1.99 sq. m)

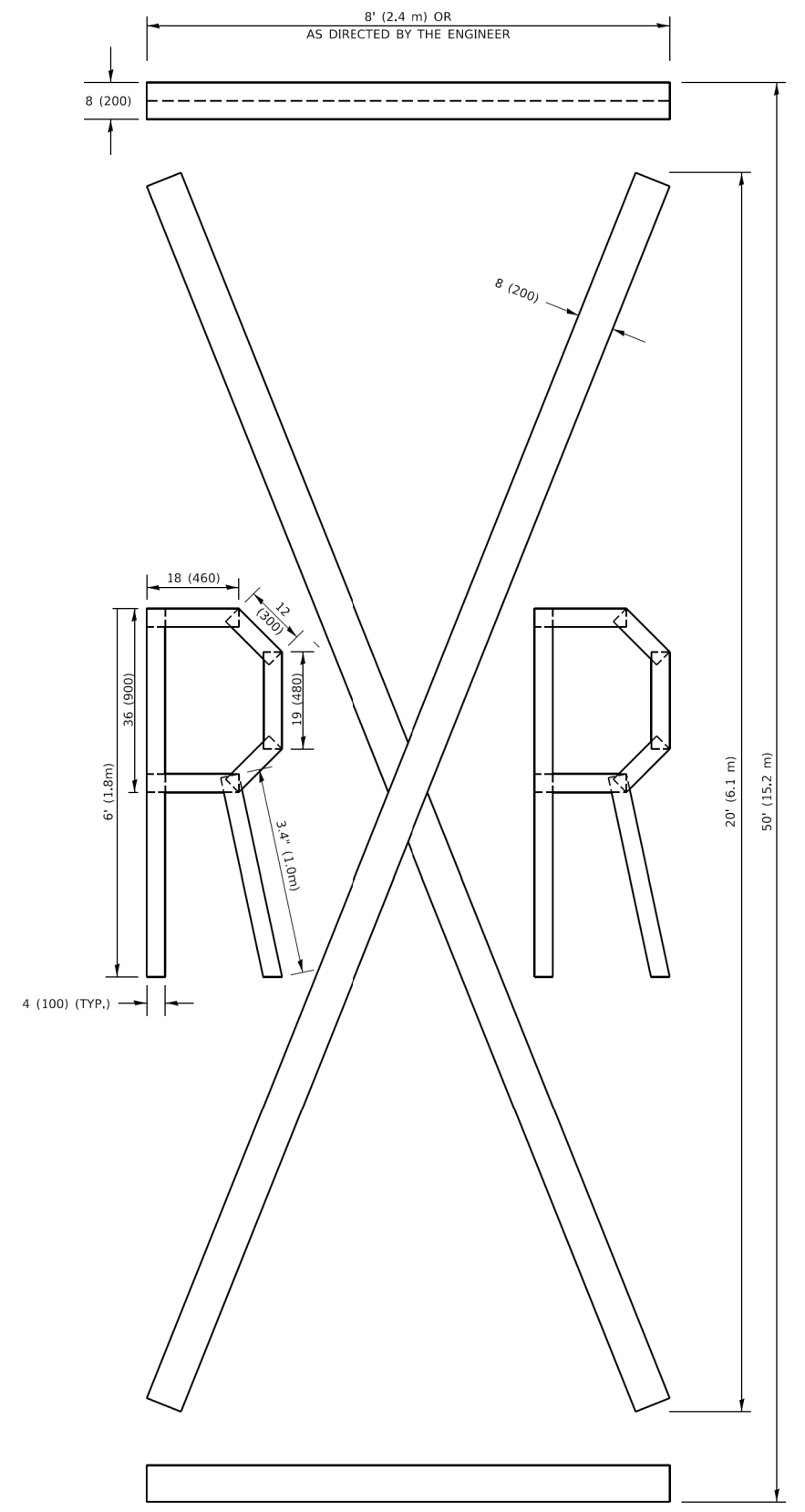

QUANTITY

4 (100) LINE = 225.9 ft. (68.9 m)
75.3 sq. ft. (6.99 sq. m)

NOTE:

ALL QUANTITIES OF PLACEMENT ARE REPRESENTED IN LINEAR FEET OF 4" LINES TO MATCH THE 4" TEMPORARY TAPE PAY ITEM AND REPRESENTS THE TOTAL QUANTITY OF 4" TAPE REQUIRED.

All dimensions are in inches (millimeters) unless otherwise shown.

MODEL: Default
FILE NAME: P:\ILLINOIS\BID\NTEG\Illinois.gov\PWIDOT\Documents\DOT_Offices\Berket_1\Projects\IDS\S22\2-24\CAD\Bna\CAD\Sheets\12.16.dgn

USER NAME = footemj	DESIGNED -	REVISED - T. RAMMACHER 03-02-98
	DRAWN -	REVISED - E. GOMEZ 08-28-00
PLOT SCALE = 50.0068" / ft.	CHECKED -	REVISED - E. GOMEZ 08-28-00
PLOT DATE = 3/4/2019	DATE - 09-18-94	REVISED - A. SCHUETZE 09-15-16

**STATE OF ILLINOIS
DEPARTMENT OF TRANSPORTATION**

SHORT TERM PAVEMENT MARKING LETTERS AND SYMBOLS

SCALE: NONE SHEET 1 OF 1 SHEETS STA. TO STA.

F.A. RTE.	SECTION	COUNTY	TOTAL SHEETS	SHEET NO.
	20-00224-00-BT	COOK	89	69
TC-16		CONTRACT NO. 61J19		
ILLINOIS		FED. AID PROJECT		

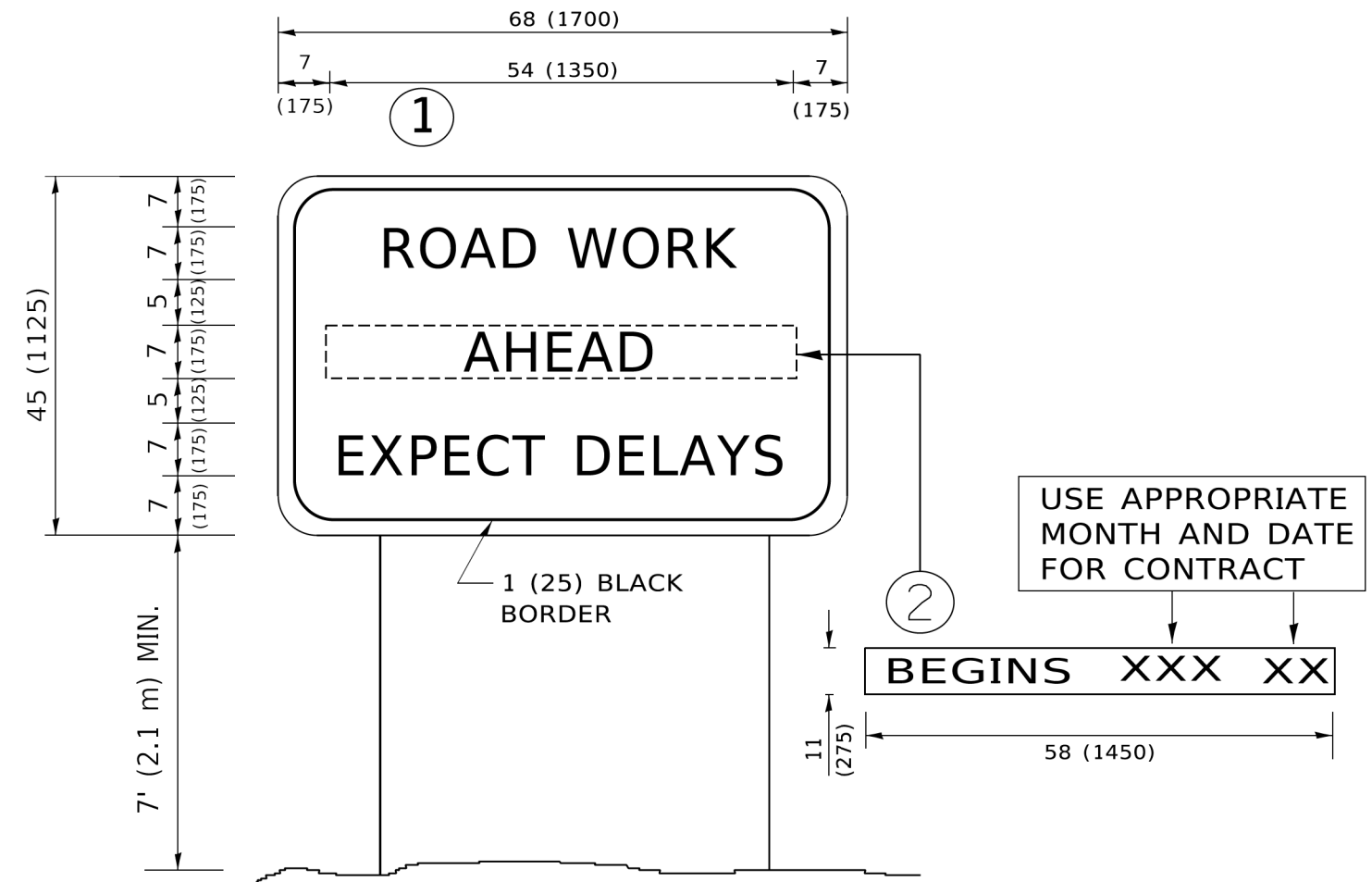

NOTES:

1. USE BLACK LETTERING ON ORANGE BACKGROUND.
2. ERECT SIGNS IN ADVANCE OF THE LOCATION FOR THE "ROAD CONSTRUCTION AHEAD" SIGN AT LOCATIONS AS DIRECTED BY THE ENGINEER.
3. ERECT SIGN ① WITH INSTALLED PANEL ② ONE WEEK PRIOR TO THE START OF CONSTRUCTION.
4. REMOVE PANEL ② SOON AFTER THE START OF CONSTRUCTION.
5. SEE SPECIAL PROVISION FOR "TEMPORARY INFORMATION SIGNING" FOR ADDITIONAL INFORMATION.
6. ONE SIGN ASSEMBLY EQUALS 25.70 SQ. FT. (2.3 SQ. M.)
7. SHALL BE PAID FOR AS TEMPORARY INFORMATION SIGNING.

ALL DIMENSIONS ARE IN INCHES (MILLIMETERS) UNLESS OTHERWISE SHOWN.

MODEL: Default
FILE NAME: P:\011084\BID\NTEG\Illinois.gov\PIWDOT\Documents\DOT_Offices\District_1\Projects\Dist1\2023-24\CADD\Info\CAD\Sheet122.dgn

USER NAME = footemj	DESIGNED -	REVISED - R. MIRS 09-15-97
	DRAWN -	REVISED - R. MIRS 12-11-97
PLOT SCALE = 50.0000' / in.	CHECKED -	REVISED - T. RAMMACHER 02-02-99
PLOT DATE = 3/4/2019	DATE -	REVISED - C. JUCIUS 01-31-07

**STATE OF ILLINOIS
DEPARTMENT OF TRANSPORTATION**

**ARTERIAL ROAD
INFORMATION SIGN**

SCALE: NONE SHEET 1 OF 1 SHEETS STA. TO STA.

F.A. RTE.	SECTION	COUNTY	TOTAL SHEETS	SHEET NO.
	20-00224-00-BT	COOK	89	70
TC-22			CONTRACT NO. 61J19	
ILLINOIS FED. AID PROJECT				

DATE	
BY	
FINAL SURVEY NO.	
SURVEYED	
PLOTTED	
TEMPLATE	
NOTE BOOK	
AREAS CHECKED	

DATE	
BY	
ORIGINAL SURVEY NO.	
SURVEYED	
PLOTTED	
TEMPLATE	
NOTE BOOK	
AREAS CHECKED	

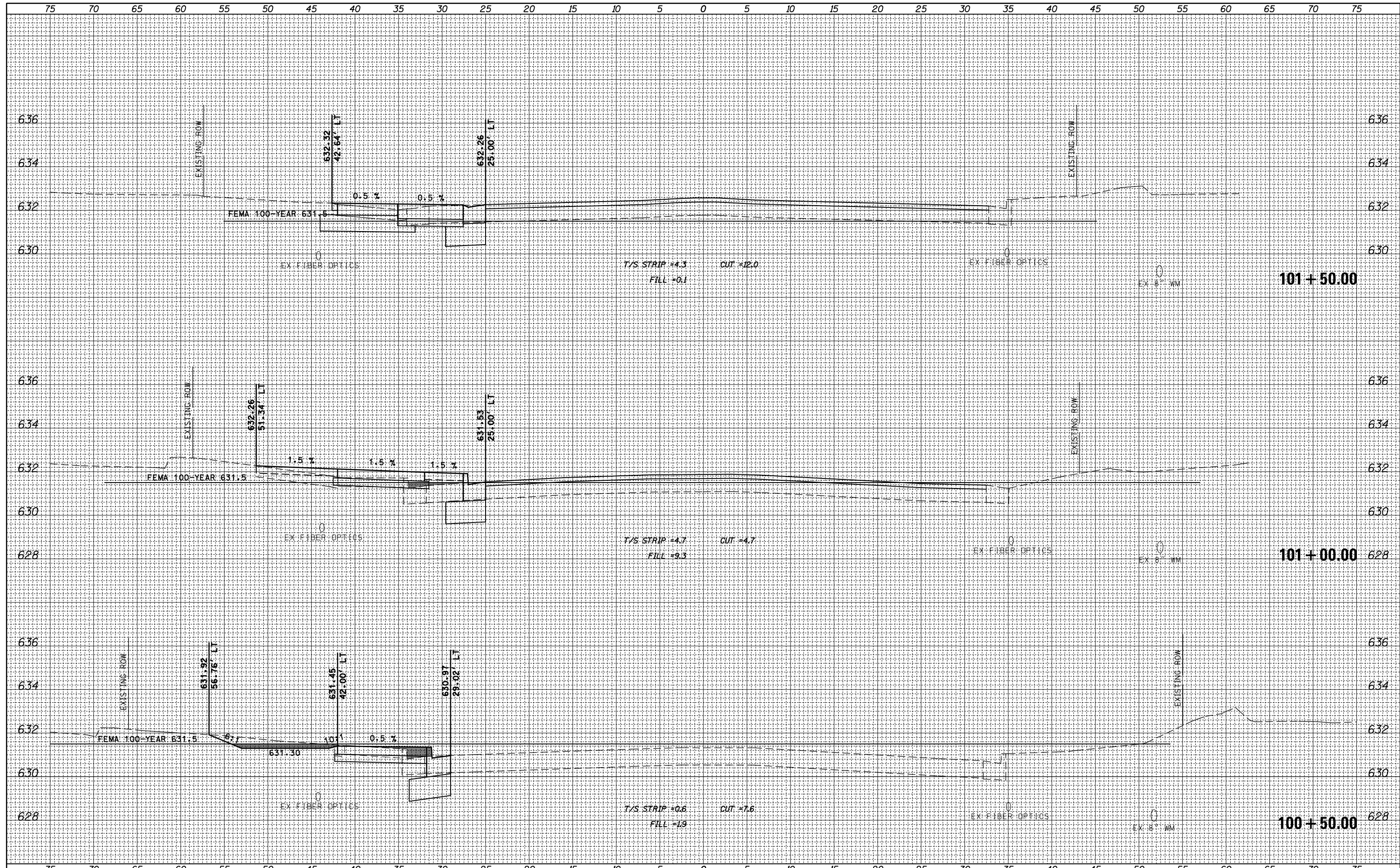

FILE NAME =	USER NAME = mthomas	DESIGNED -	REVISED -	STATE OF ILLINOIS DEPARTMENT OF TRANSPORTATION	OAKTON STREET SIDEPATH CROSS SECTION		F.A. RTE.	SECTION	COUNTY	TOTAL SHEETS	SHEET NO.		
N:\DESPLAINES\190138.00003\Civil\XS_OAKTON_19138-03_03.sht		DRAWN -	REVISED -		SCALE:	SHEET	OF	SHEETS	STA. 100+50.00	TO STA. 101+50.00	COOK	89	71
PLOT SCALE = 18"		CHECKED -	REVISED -								CONTRACT NO. 61J19		
Default	PLOT DATE = 11/16/2022	DATE -	REVISED -								ILLINOIS FED. AID PROJECT		

DATE	
BY	
FINAL SURVEY	SURVEYED
NOTE BOOK	PLOTTED
NO.	TEMPLATE
	AREAS
	CHECKED

DATE	
BY	
ORIGINAL SURVEY	SURVEYED
NOTE BOOK	PLOTTED
NO.	TEMPLATE
	AREAS
	CHECKED

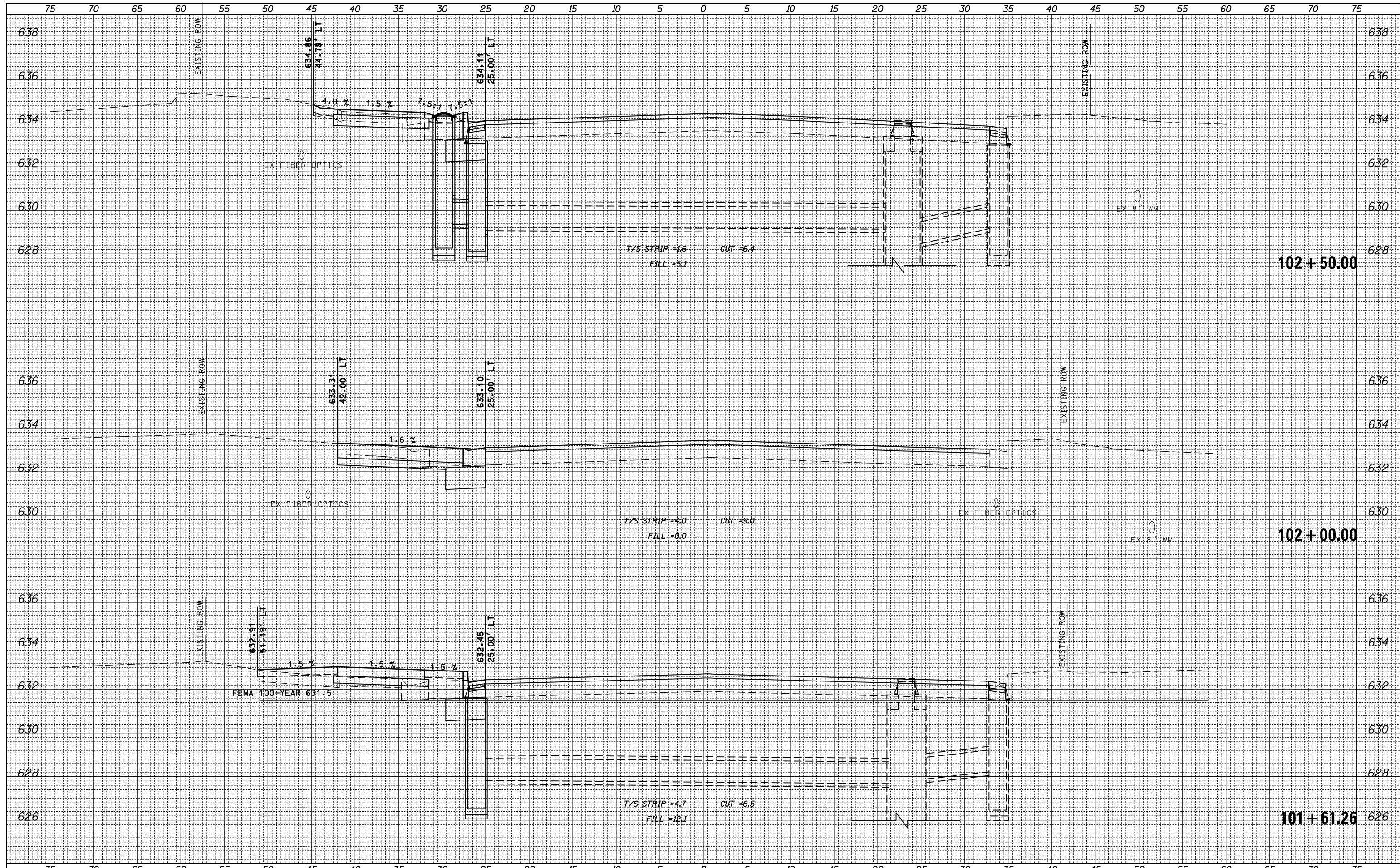

FILE NAME =	USER NAME = mthomas	DESIGNED -	REVISED -	STATE OF ILLINOIS DEPARTMENT OF TRANSPORTATION	OAKTON STREET SIDEWALK CROSS SECTION	F.A. RTE.	SECTION	COUNTY	TOTAL SHEETS	SHEET NO.
N:\DESPLAINES\190138.00003\Civil\XS_OAKTON_19138-03.03.sht	PLOT SCALE = 10'	DRAWN -	REVISED -			20-00224-00-BT	COOK	89	72	
Default	PLOT DATE = 11/16/2022	CHECKED -	REVISED -			CONTRACT NO. 61J19				
		DATE -	REVISED -			ILLINOIS FED. AID PROJECT				

SCALE: SHEET OF SHEETS STA. 101+61.26 TO STA. 102+50.00

DATE	
BY	
SURVEYED	
PLOTTED	
TEMPLATE	
AREAS	
CHECKED	
FINAL SURVEY	
NOTE BOOK	
NO.	

DATE	
BY	
SURVEYED	
PLOTTED	
TEMPLATE	
AREAS	
CHECKED	
ORIGINAL SURVEY	
NOTE BOOK	
NO.	

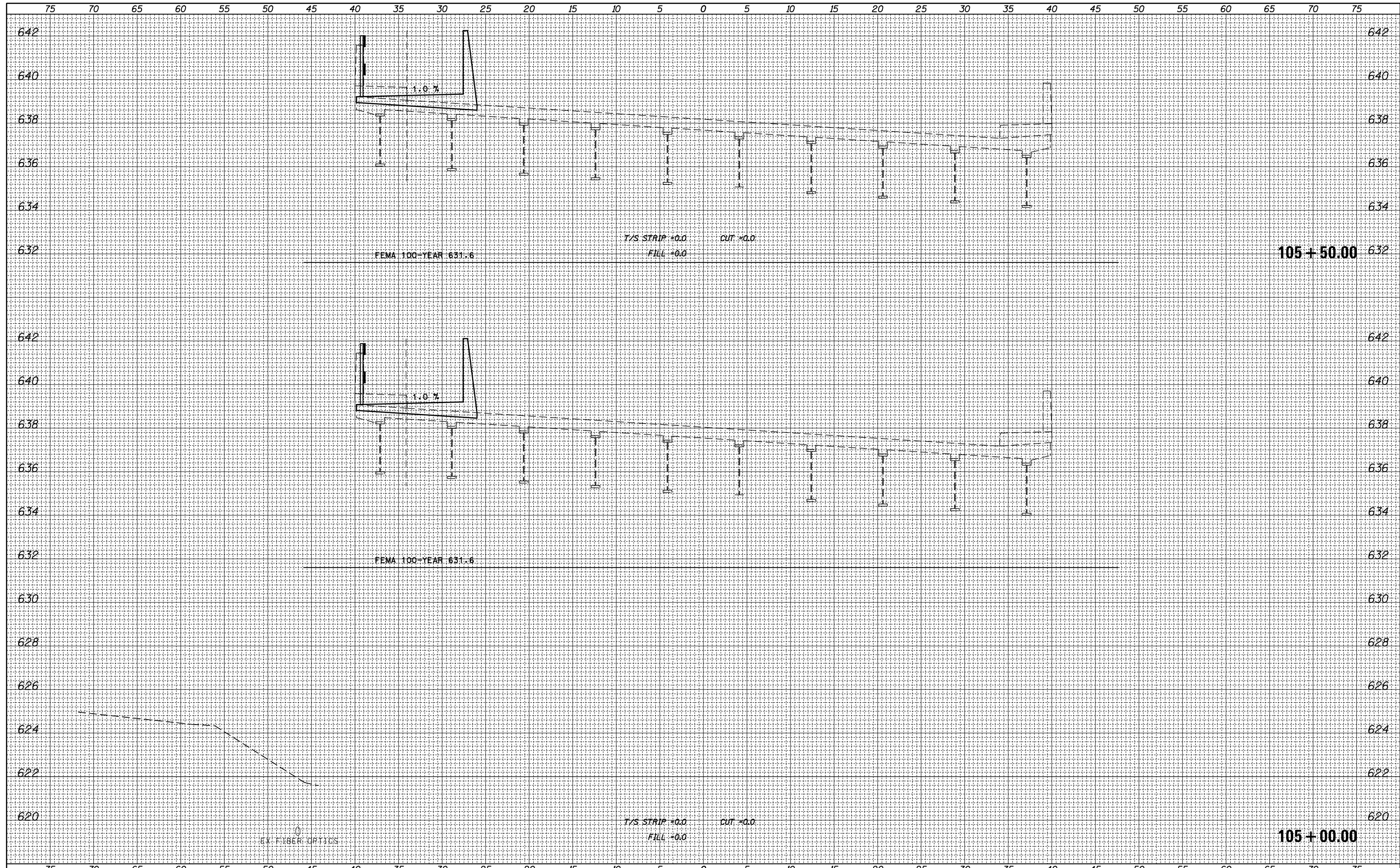

FILE NAME =	USER NAME = mthomas	DESIGNED -	REVISED -	STATE OF ILLINOIS DEPARTMENT OF TRANSPORTATION	OAKTON STREET SIDEPATH CROSS SECTION	F.A. RTE.	SECTION	COUNTY	TOTAL SHEETS	SHEET NO.
N:\DESPLAINES\190138.00003\Civil\XS_OAKTON_19138-03_03.sht		DRAWN -	REVISED -			20-00224-00-BT	COOK	89	75	
PLOT SCALE = 10'		CHECKED -	REVISED -			CONTRACT NO. 61J19				
PLOT DATE = 11/16/2022		DATE -	REVISED -			ILLINOIS FED. AID PROJECT				
Default				SCALE:	SHEET	OF	SHEETS	STA. 105+00.00	TO STA. 105+50.00	

DATE	
BY	
FINAL SURVEY	SURVEYED
NOTE BOOK	PLOTTED
NO.	TEMPLATE
	AREAS
	CHECKED

DATE	
BY	
ORIGINAL SURVEY	SURVEYED
NOTE BOOK	PLOTTED
NO.	TEMPLATE
	AREAS
	CHECKED

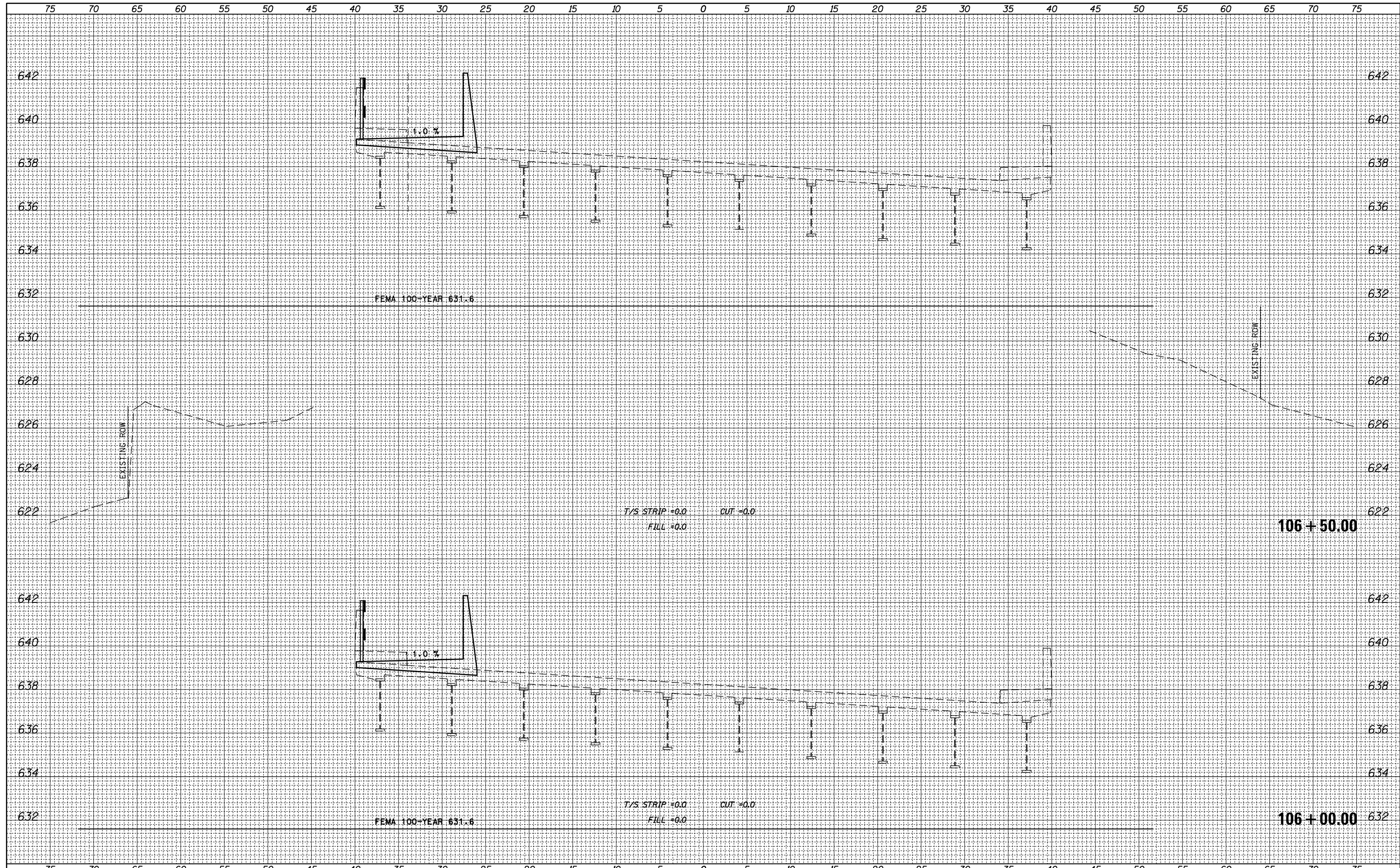

FILE NAME =	USER NAME = mthomas	DESIGNED -	REVISED -	STATE OF ILLINOIS DEPARTMENT OF TRANSPORTATION	OAKTON STREET SIDEWALK CROSS SECTION	F.A. RTE.	SECTION	COUNTY	TOTAL SHEETS	SHEET NO.
N:\DESPLAINES\190138.00003\Civil\XS_OAKTON.19138-03.03.sht		DRAWN -	REVISED -			20-00224-00-BT	COOK	89	76	
Default	PLOT SCALE = 10'	CHECKED -	REVISED -			CONTRACT NO. 61J19				
	PLOT DATE = 11/16/2022	DATE -	REVISED -			ILLINOIS FED. AID PROJECT				

DATE	
BY	
FINAL SURVEY	SURVEYED
NOTE BOOK	PLOTTED
NO.	TEMPLATE
	AREAS
	CHECKED

DATE	
BY	
ORIGINAL SURVEY	SURVEYED
NOTE BOOK	PLOTTED
NO.	TEMPLATE
	AREAS
	CHECKED

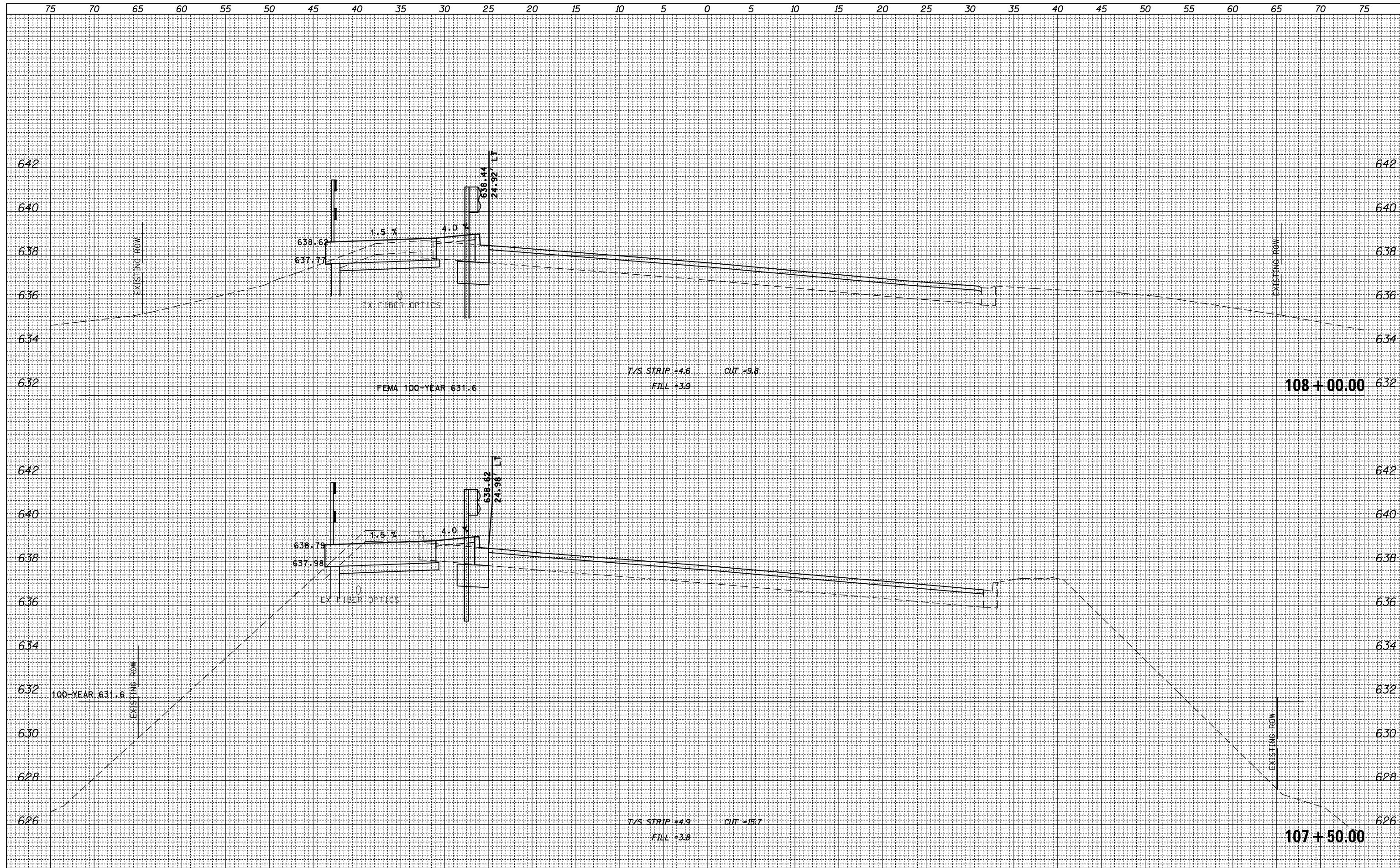

FILE NAME = N:\DESPLAINES\190138.00003\Civil\XS_OAKTON.19138-03.03.sht
 USER NAME = mthomas
 PLOT SCALE = 1"=10'
 PLOT DATE = 11/16/2022

DESIGNED	-	REVISED	-
DRAWN	-	REVISED	-
CHECKED	-	REVISED	-
DATE	-	REVISED	-

**STATE OF ILLINOIS
DEPARTMENT OF TRANSPORTATION**

**OAKTON STREET SIDEWALK
CROSS SECTION**

SCALE: SHEET OF SHEETS STA. 107+50.00 TO STA. 108+00.00

F.A. RTE.	SECTION	COUNTY	TOTAL SHEETS	SHEET NO.
	20-00224-00-BT	COOK	89	78
CONTRACT NO. 61J19				
ILLINOIS FED. AID PROJECT				

DATE	
BY	
FINAL SURVEY	SURVEYED
NOTE BOOK NO.	PLOTTED
	TEMPLATE
	AREAS CHECKED

DATE	
BY	
ORIGINAL SURVEY	SURVEYED
NOTE BOOK NO.	PLOTTED
	TEMPLATE
	AREAS CHECKED

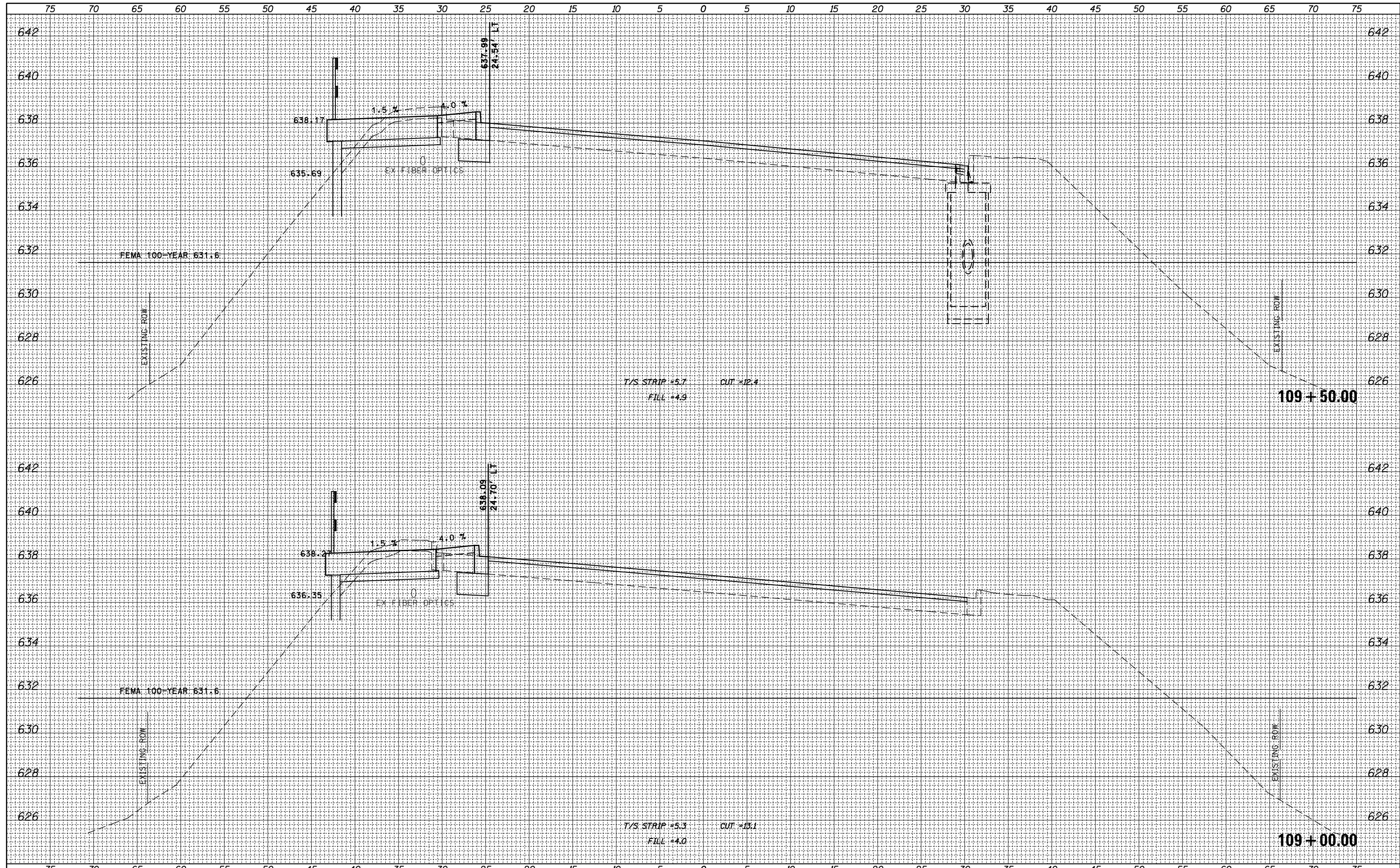

FILE NAME =	USER NAME = mthomas	DESIGNED -	REVISED -	STATE OF ILLINOIS DEPARTMENT OF TRANSPORTATION	OAKTON STREET SIDEWALK CROSS SECTION	F.A. RTE.	SECTION	COUNTY	TOTAL SHEETS	SHEET NO.
N:\DESPLAINES\190138\00003\Civil\XS_OAKTON_19138-03_03.sht		DRAWN -	REVISED -			20-00224-00-BT	COOK	89	80	
Default	PLOT SCALE = 10'	CHECKED -	REVISED -			CONTRACT NO. 61J19				
	PLOT DATE = 11/16/2022	DATE -	REVISED -			ILLINOIS FED. AID PROJECT				

DATE	
BY	
FINAL SURVEY	SURVEYED
NOTE BOOK	PLOTTED
NO.	TEMPLATE
	AREAS CHECKED

DATE	
BY	
ORIGINAL SURVEY	SURVEYED
NOTE BOOK	PLOTTED
NO.	TEMPLATE
	AREAS CHECKED

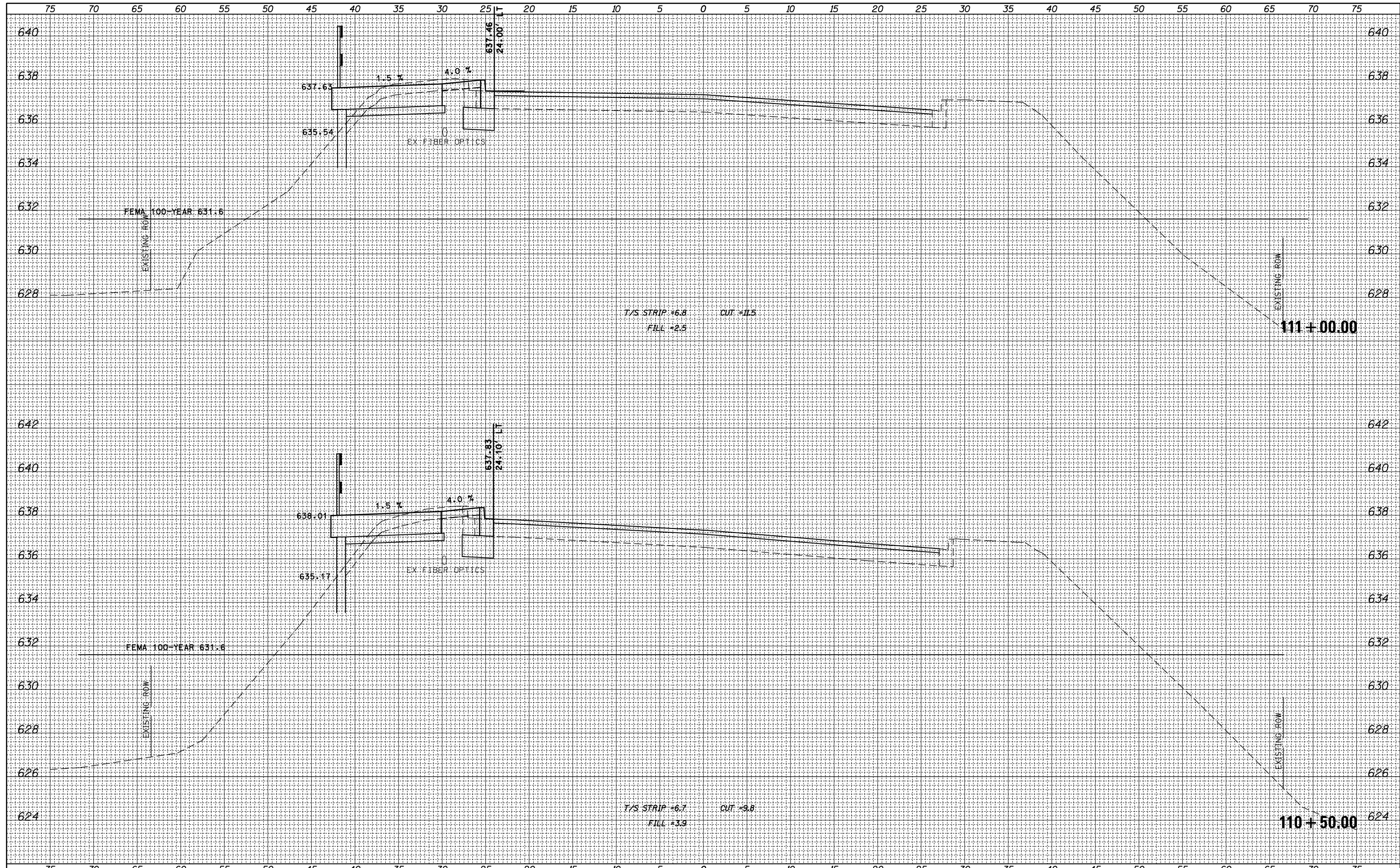

FILE NAME = N:\DESPLAINES\190138.00003\Civil\XS_OAKTON_19138-03_03.sht	USER NAME = mthomas	DESIGNED -	REVISED -	STATE OF ILLINOIS DEPARTMENT OF TRANSPORTATION	OAKTON STREET SIDEWALK CROSS SECTION	F.A. RTE.	SECTION	COUNTY	TOTAL SHEETS	SHEET NO.
Default	PLOT SCALE = 18'	DRAWN -	REVISED -			20-00224-00-BT	COOK	89	82	
	PLOT DATE = 11/16/2022	CHECKED -	REVISED -			CONTRACT NO. 61J19				
		DATE -	REVISED -			ILLINOIS FED. AID PROJECT				

DATE	
BY	
FINAL SURVEY	SURVEYED
NOTE BOOK	PLOTTED
NO.	TEMPLATE
	AREAS
	CHECKED

DATE	
BY	
ORIGINAL SURVEY	SURVEYED
NOTE BOOK	PLOTTED
NO.	TEMPLATE
	AREAS
	CHECKED

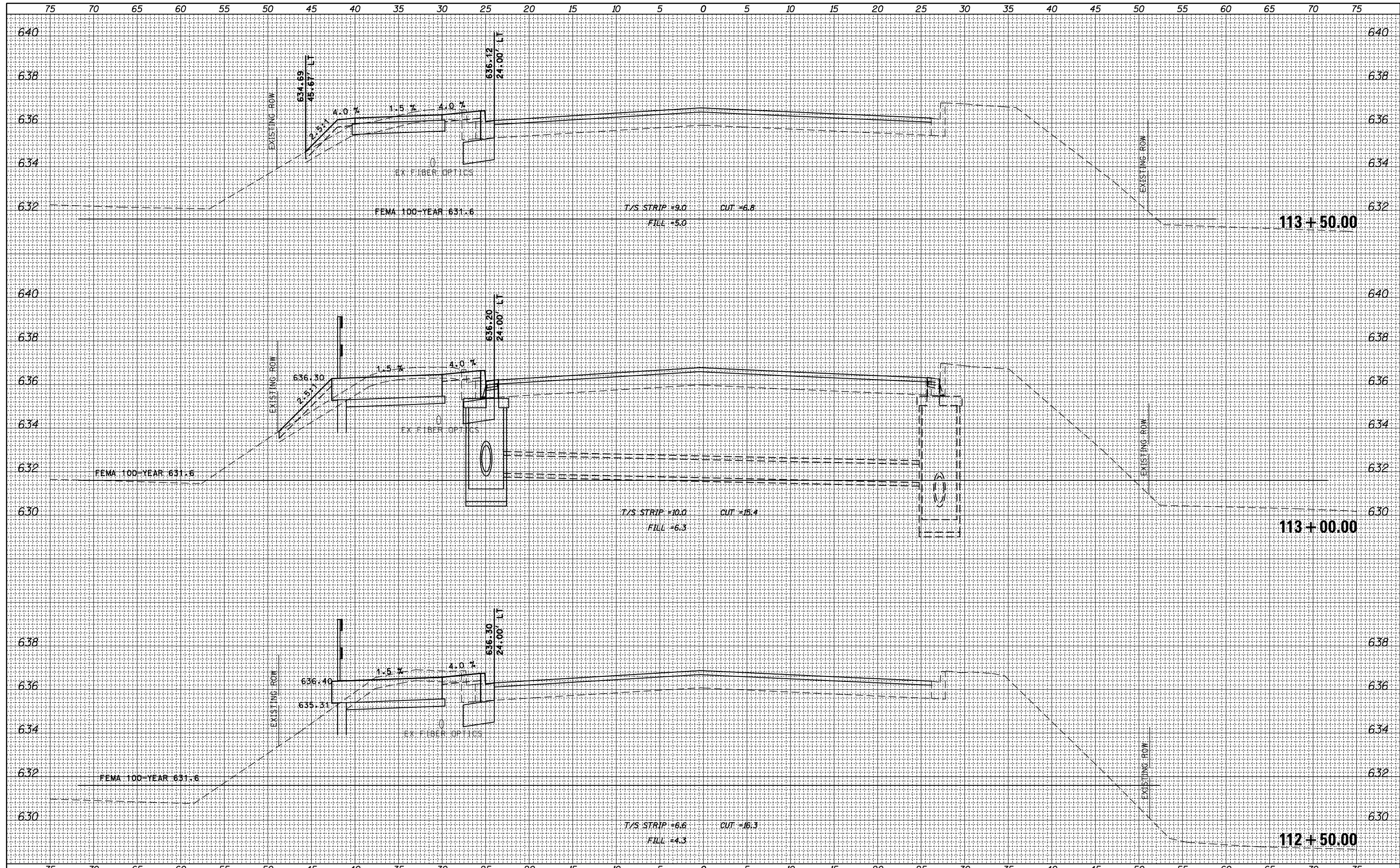

FILE NAME =	USER NAME = mthomas	DESIGNED -	REVISED -	STATE OF ILLINOIS DEPARTMENT OF TRANSPORTATION	OAKTON STREET SIDEWALK CROSS SECTION			F.A. RTE.	SECTION	COUNTY	TOTAL SHEETS	SHEET NO.
N:\DESPLAINES\190138\00003\Civil\XS_OAKTON_19138-03_03.sht		DRAWN -	REVISED -					20-00224-00-BT	COOK	89	84	
Default	PLOT SCALE = 18"	CHECKED -	REVISED -					CONTRACT NO. 61J19				
	PLOT DATE = 11/16/2022	DATE -	REVISED -					ILLINOIS FED. AID PROJECT				

DATE	
BY	
FINAL SURVEY	SURVEYED
NOTE BOOK	PLOTTED
NO.	TEMPLATE
	AREAS
	CHECKED

DATE	
BY	
ORIGINAL SURVEY	SURVEYED
NOTE BOOK	PLOTTED
NO.	TEMPLATE
	AREAS
	CHECKED

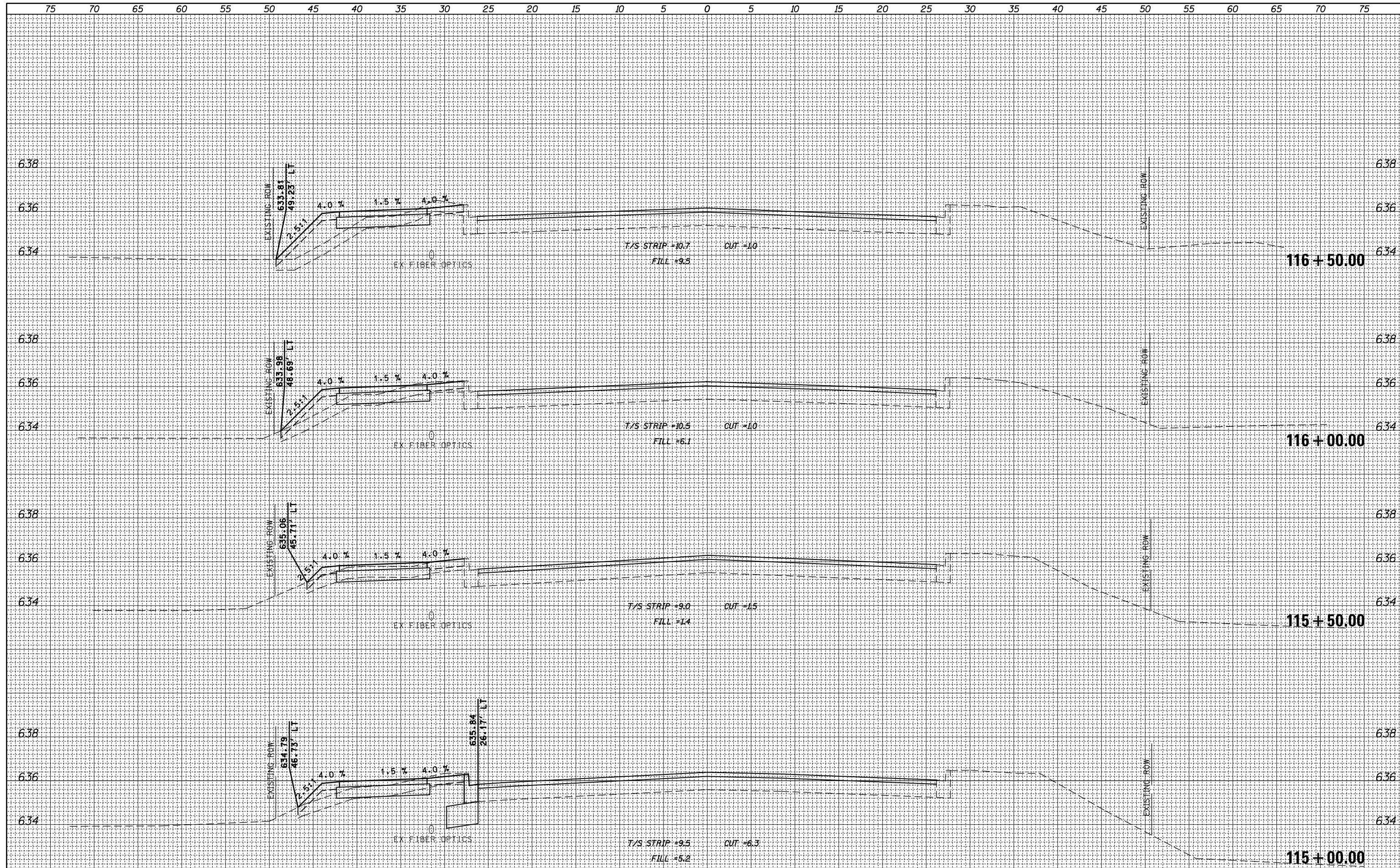

FILE NAME =	USER NAME = mthomas	DESIGNED -	REVISED -	STATE OF ILLINOIS DEPARTMENT OF TRANSPORTATION	OAKTON STREET SIDEPAH CROSS SECTION			F.A. RTE.	SECTION	COUNTY	TOTAL SHEETS	SHEET NO.
N:\DESPLAINES\190138\00003\Civil\XS_OAKTON_19138-03_03.sht		DRAWN -	REVISED -					20-00224-00-BT	COOK	89	86	
PLOT SCALE = 10'		CHECKED -	REVISED -					CONTRACT NO. 61J19				
PLOT DATE = 11/16/2022		DATE -	REVISED -					ILLINOIS FED. AID PROJECT				
Default				SCALE:	SHEET	OF	SHEETS	STA. 115+00.00	TO STA. 116+50.00			

DATE	
BY	
FINAL SURVEY	SURVEYED
NOTE BOOK	PLOTTED
NO.	TEMPLATE
	AREAS CHECKED
	AREAS CHECKED

DATE	
BY	
ORIGINAL SURVEY	SURVEYED
NOTE BOOK	PLOTTED
NO.	TEMPLATE
	AREAS CHECKED
	AREAS CHECKED

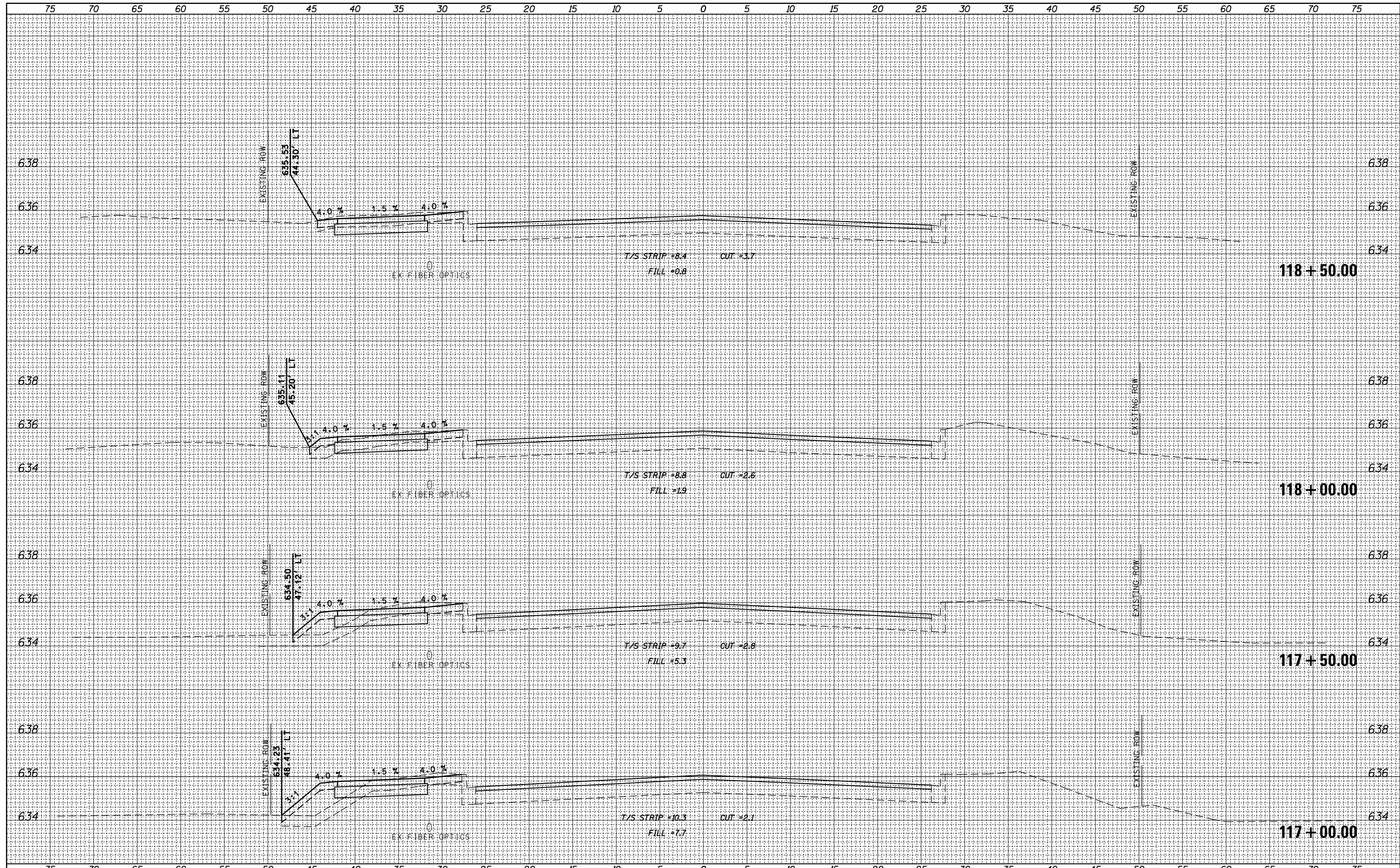

FILE NAME =	USER NAME = mthomas	DESIGNED -	REVISED -	STATE OF ILLINOIS DEPARTMENT OF TRANSPORTATION	OAKTON STREET SIDEPATH CROSS SECTION		F.A. RTE.	SECTION	COUNTY	TOTAL SHEETS	SHEET NO.	
N:\DESPLAINES\190138.00003\Civil\XS_OAKTON_19138-03.03.sht		DRAWN -	REVISED -		SCALE:	SHEET	OF	SHEETS	STA. 117+00.00	TO STA. 118+50.00	ILLINOIS FED. AID PROJECT	
Default	PLOT SCALE = 10'	CHECKED -	REVISED -									
	PLOT DATE = 11/16/2022	DATE -	REVISED -									

DATE	
BY	
ORIGINAL SURVEY	
SURVEYED	
PLOTTED	
TEMPLATE	
AREAS CHECKED	
NO.	

DATE	
BY	
ORIGINAL SURVEY	
SURVEYED	
PLOTTED	
TEMPLATE	
AREAS CHECKED	
NO.	

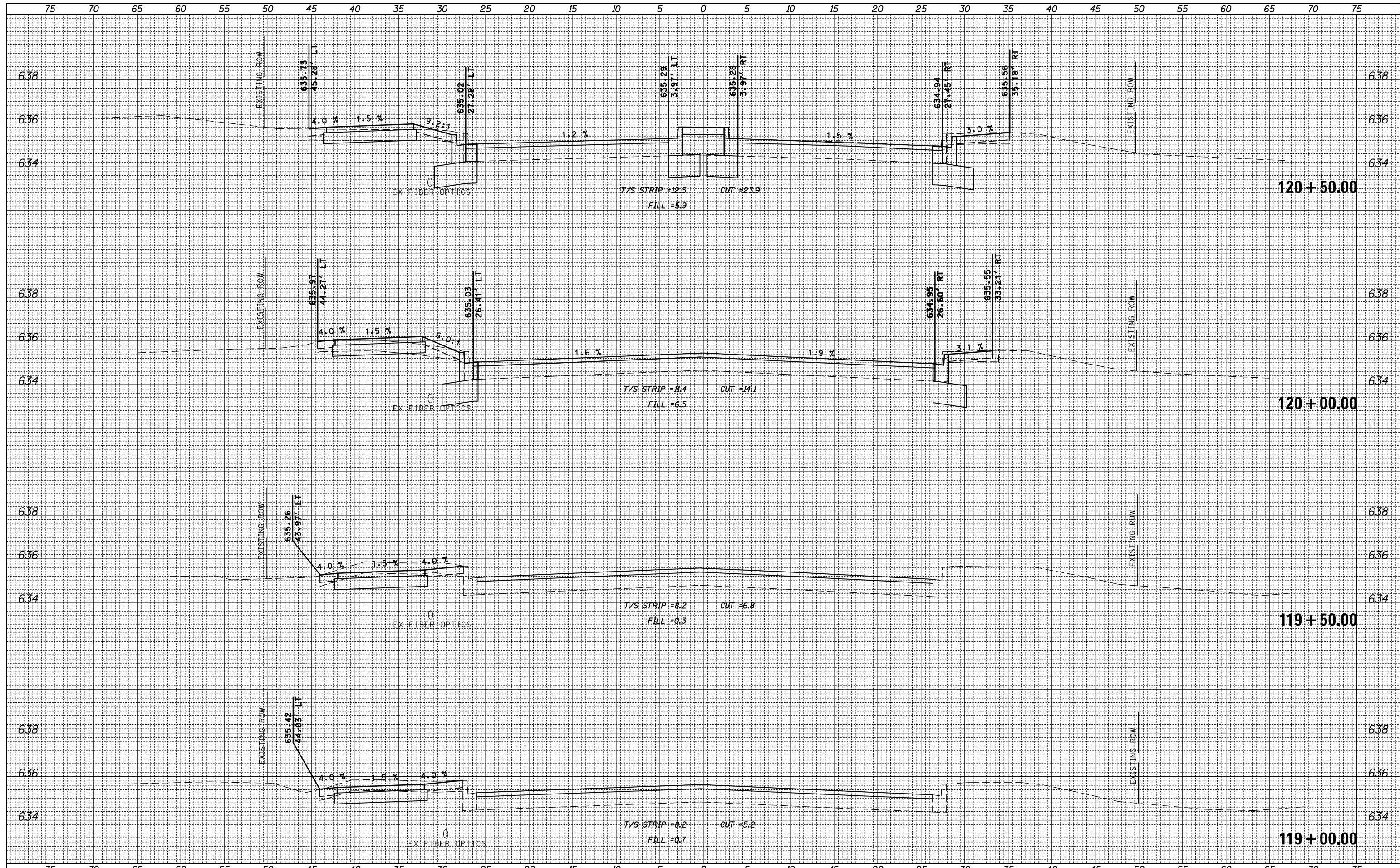

FILE NAME =	USER NAME = mthomas	DESIGNED -	REVISED -	STATE OF ILLINOIS DEPARTMENT OF TRANSPORTATION	OAKTON STREET SIDEWALK CROSS SECTION	F.A. RTE.	SECTION	COUNTY	TOTAL SHEETS	SHEET NO.
N:\DESPLAINES\190138.00003\Civil\XS_OAKTON_19138-03_03.sht		DRAWN -	REVISED -			20-00224-00-BT	COOK	89	88	
PLOT SCALE = 10'		CHECKED -	REVISED -			CONTRACT NO. 61J19				
Default	PLOT DATE = 11/16/2022	DATE -	REVISED -			ILLINOIS FED. AID PROJECT				

SCALE: SHEET OF SHEETS STA. 119+00.00 TO STA. 120+50.00

DATE	
BY	
SURVEYED	
PLOTTED	
TEMPLATE	
AREAS CHECKED	
NO.	

DATE	
BY	
SURVEYED	
PLOTTED	
TEMPLATE	
AREAS CHECKED	
NO.	

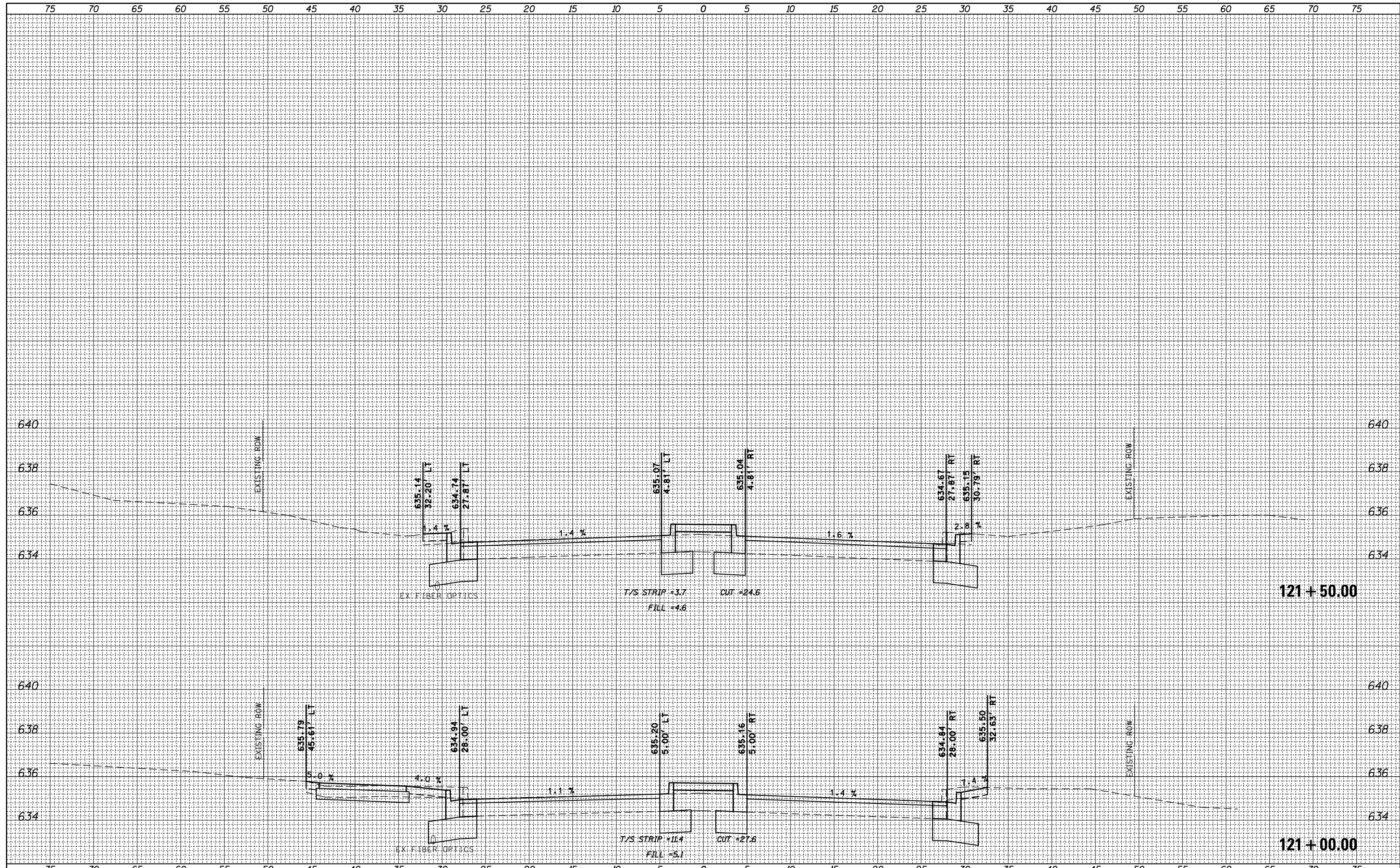

FILE NAME = N:\DESPLAINES\190138\00003\Civil\XS_OAKTON_19138-03_03.sht	USER NAME = mthomas	DESIGNED -	REVISED -	STATE OF ILLINOIS DEPARTMENT OF TRANSPORTATION	OAKTON STREET SIDEWALK CROSS SECTION		F.A. RTE.	SECTION	COUNTY	TOTAL SHEETS	SHEET NO.	
Default	PLOT SCALE = 10'	DRAWN -	REVISED -		SCALE:	SHEET	OF	SHEETS	STA. 121+00.00	TO STA. 121+50.00	COOK	89
	PLOT DATE = 11/16/2022	CHECKED -	REVISED -								CONTRACT NO. 61J19	
		DATE -	REVISED -								ILLINOIS FED. AID PROJECT	