

F.A.I. RTE.	SECTION	COUNTY	TOTAL SHEETS	SHEET NO.
90/94	2021-922PT.1-AC	COOK	460	102
STA.	TO STA.			
FED. ROAD DIST. NO. 1	ILLINOIS	FED. AID PROJECT		

62693

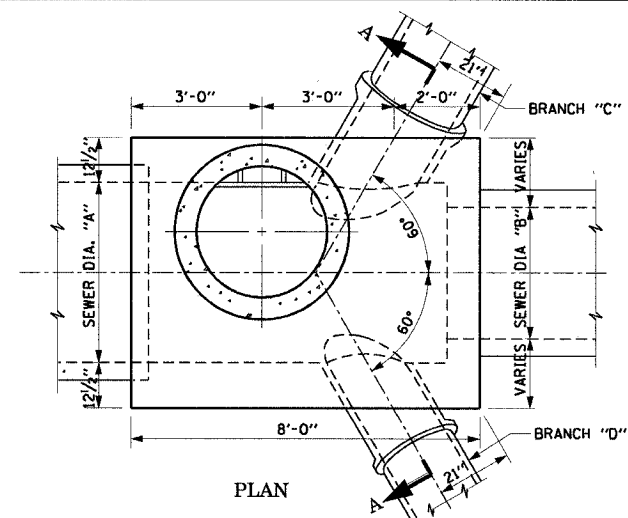

PLAN

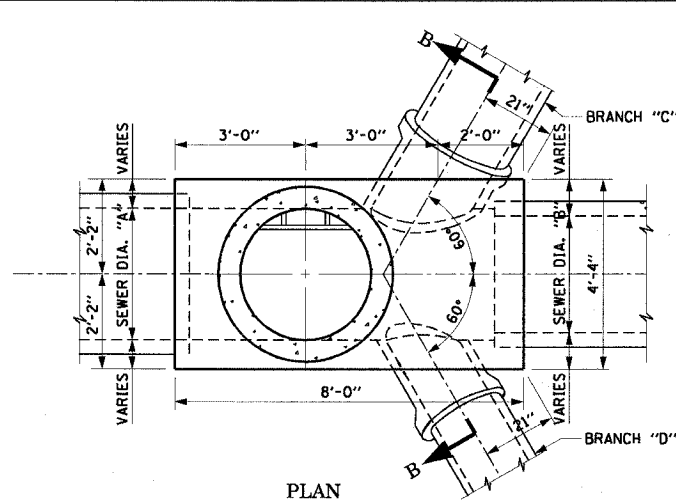

PLAN

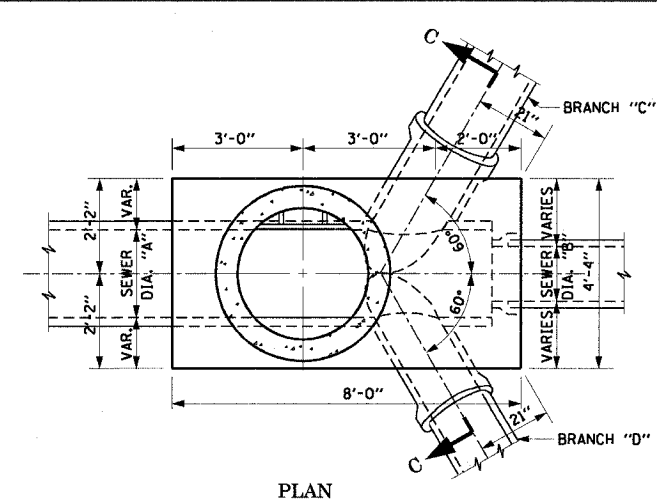

PLAN

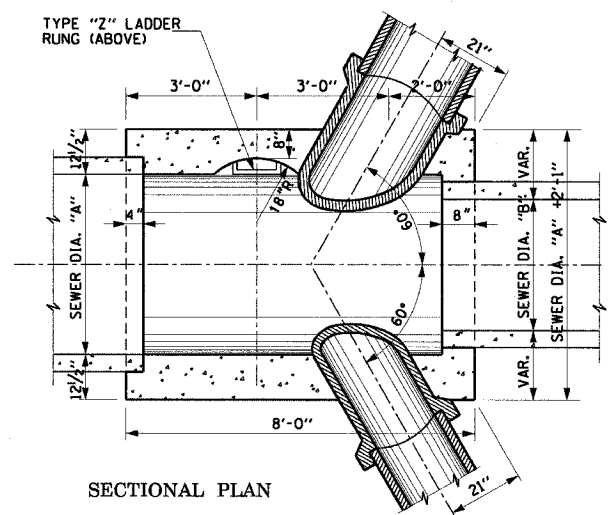

SECTIONAL PLAN

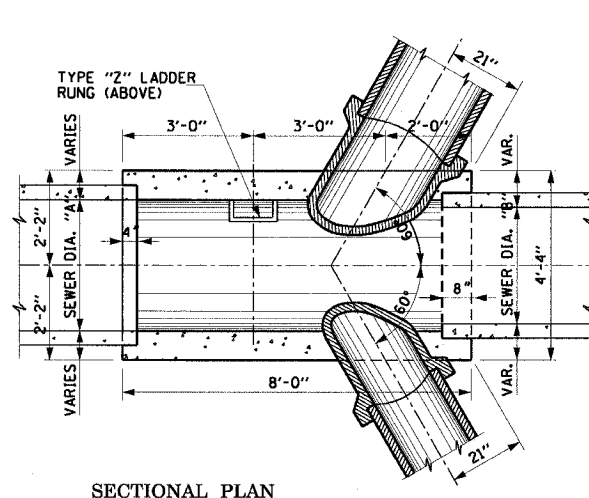

SECTIONAL PLAN

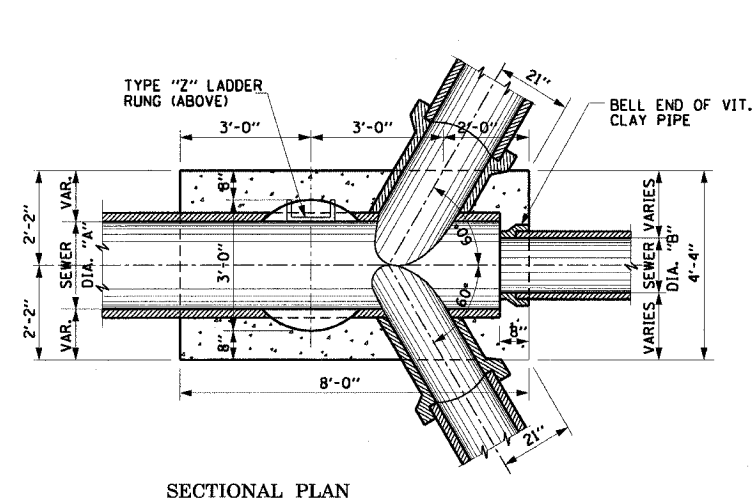

SECTIONAL PLAN

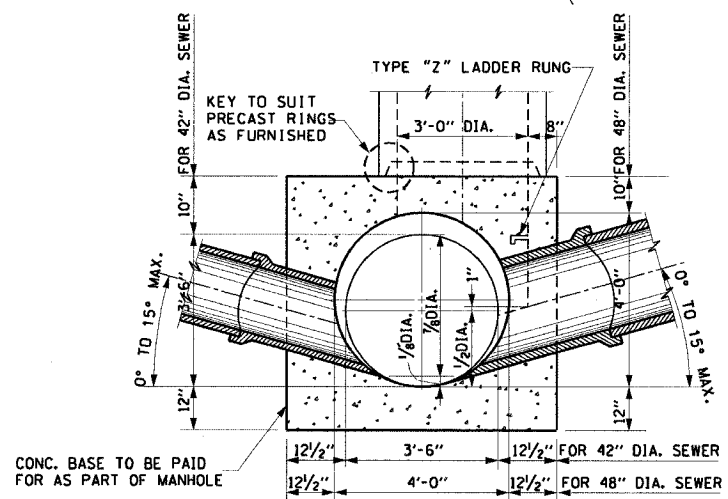

SECTION A-A

TYPE "B" MANHOLE FOR SEWER 48" DIA. AND 42" DIA.

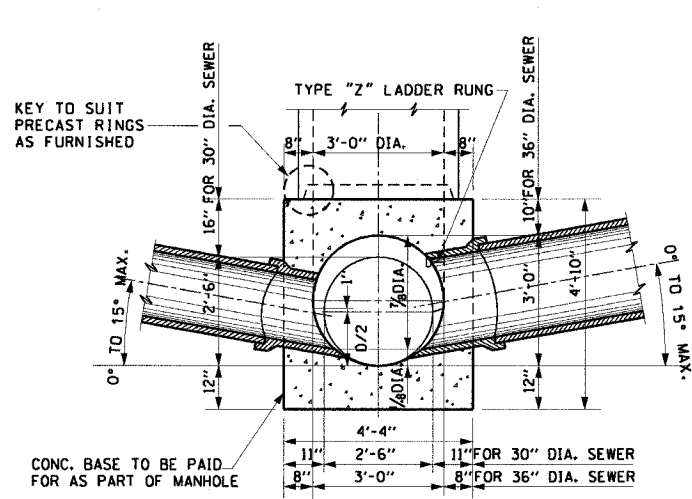

SECTION B-B

TYPE "B" MANHOLE FOR SEWER 36" DIA. AND 30" DIA.

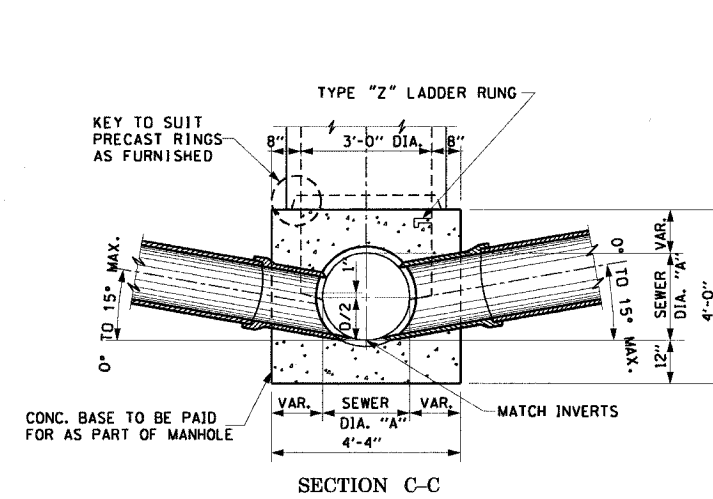

SECTION C-C TYPE "B" MANHOLE FOR SEWER 24" DIA. AND SMALLER

REVISIONS	
NAME	DATE

V:\tech\m\p\0406\p\0406\c\1\14c-crit\3c\3c\drainage and utility plans\040607.dwg