

RTE.	SECTION	COUNTY	TOTAL SHEETS	SHEET NO.
FA180	(50-2)HBR	LA SALLE	460	124
STA.	TO STA.			
FED. ROAD DIST. NO.	ILLINOIS	FED. AID PROJECT		

**CONTRACT NO. 86603**

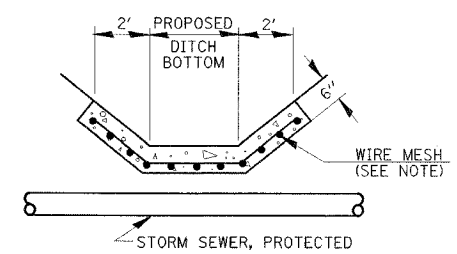

**DETAIL C**  
NO SCALE

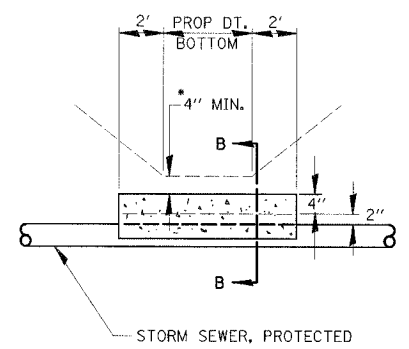
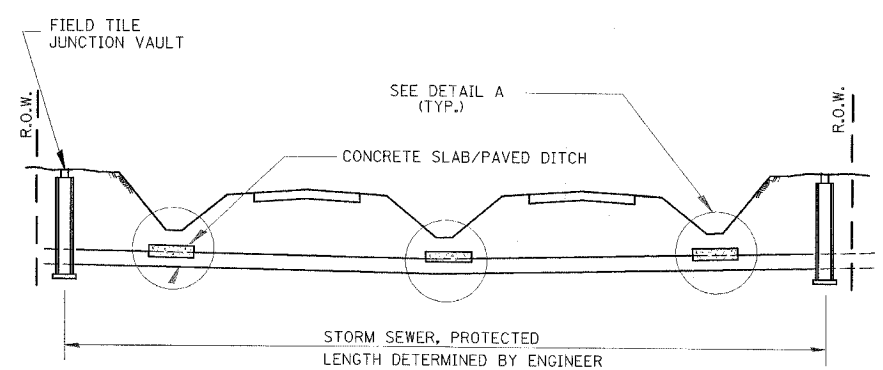
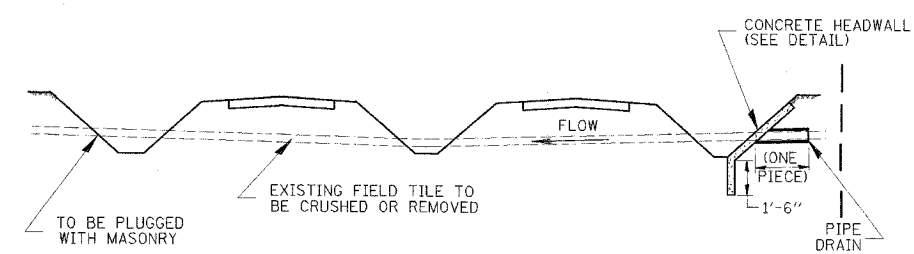

**DETAIL A**  
NO SCALE

- \*IF A 4" COVER CAN NOT BE PROVIDED A PAVED DITCH SHALL BE CONSTRUCTED AS SHOWN IN DETAIL C.
- NOTES
1. WIDTH OF CONCRETE SLAB SHALL BE THE SAME AS THE TRENCH WIDTH IN ACCORDANCE WITH SECTION 550 OF THE STD. SPECIFICATIONS, OR 3' MIN.
  2. CONCRETE FOR SLAB, HEADWALL AND PAVED DITCH SHALL BE PAID FOR AT THE CONTRACT UNIT PRICE PER CUBIC YARD FOR MISCELLANEOUS CONCRETE."
  3. COST OF FURNISHING AND INSTALLING WIRE MESH SHALL BE INCLUDED IN THE CONTRACT UNIT PRICE PER CUBIC YARD FOR MISCELLANEOUS CONCRETE. WIRE MESH TO WEIGH NOT LESS THAN 58# PER 100 SQ. FT.

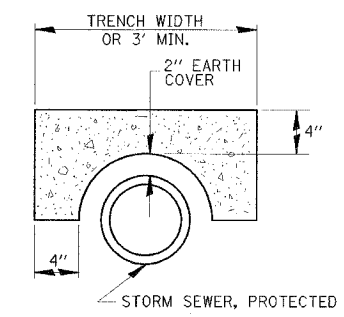

ALTERNATE MATERIALS FOR WALLS	T
PRECAST REINFORCED CONCRETE RISERS	4"
CONCRETE MASONRY UNIT	5"
MONOLITHIC CONCRETE	6"
BUILDING BRICK, GRADE SW FROM CLAY OR SHALE	8"
CONCRETE BUILDING BRICK, GRADE A	8"

**NOTES**

1. THE CONTRACT UNIT PRICE FOR FIELD TILE JUNCTION VAULT SHALL INCLUDE THE COST OF FURNISHING AND PLACING THE FRAME AND GRATE OR PRECAST CONCRETE LID AND WHEN REQUIRED, THE SAND CUSHION.
2. ALL FIELD TILE JUNCTION VAULTS SHALL BE 2'-0" IN DIAMETER UNLESS OTHERWISE NOTED ON THE PLANS.

**FIELD TILE REPLACEMENT**

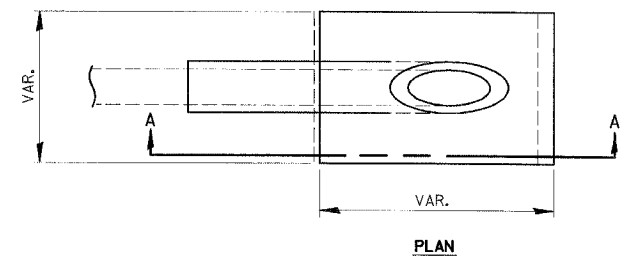

- NOTES
1. ANY STORM SEWER SPECIAL OR BACKSLOPE DRAIN OUTLET INTO A DITCH SHALL HAVE A HEADWALL BUILT IN ACCORDANCE WITH THIS DETAIL.
  2. COST OF FURNISHING AND INSTALLING WIRE MESH SHALL BE INCLUDED IN THE CONTRACT UNIT PRICE PER CUBIC YARD FOR MISCELLANEOUS CONCRETE. WIRE MESH TO WEIGH NOT LESS THAN 58# PER 100 SQ. FT.

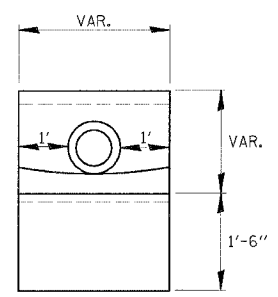
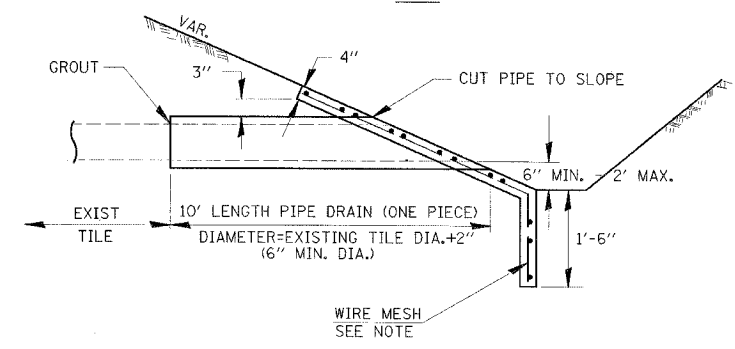

**END VIEW**

**CLASS SI CONCRETE HEADWALLS**

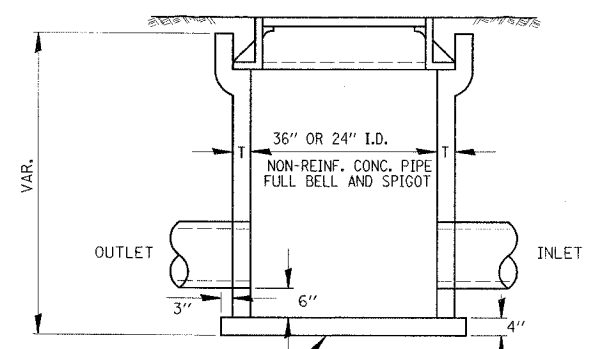

CLASS SI CONCRETE OR PRECAST REINFORCED CONCRETE SLABS NOT LESS THAN 12" WIDE

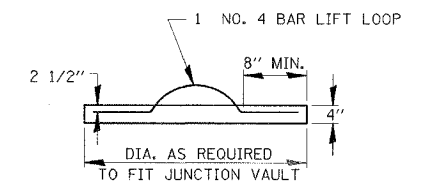
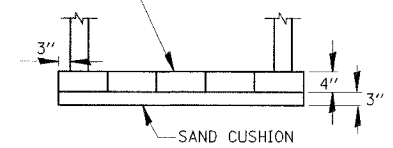

**FIELD TILE JUNCTION VAULT**

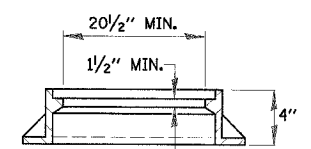
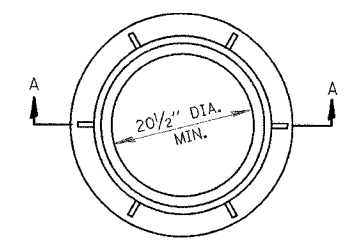

**SECTION A-A**

REVISIONS	NAME

ILLINOIS DEPARTMENT OF TRANSPORTATION

**FIELD TILE DETAILS**

F.A.I. 80 AT ILLINOIS ROUTE 351

SCALE: NONE  
DATE: 09/04

DRAWN BY: JJK  
CHECKED BY: MTD