

SECTION A-A
As an alternate to bolts, may use galvanized drive-fit caps installed after galvanizing frame.

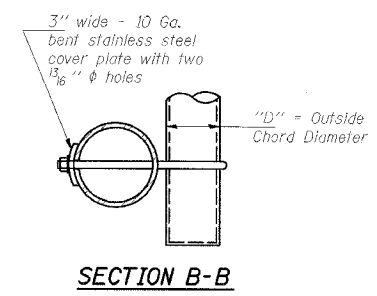

SECTION B-B

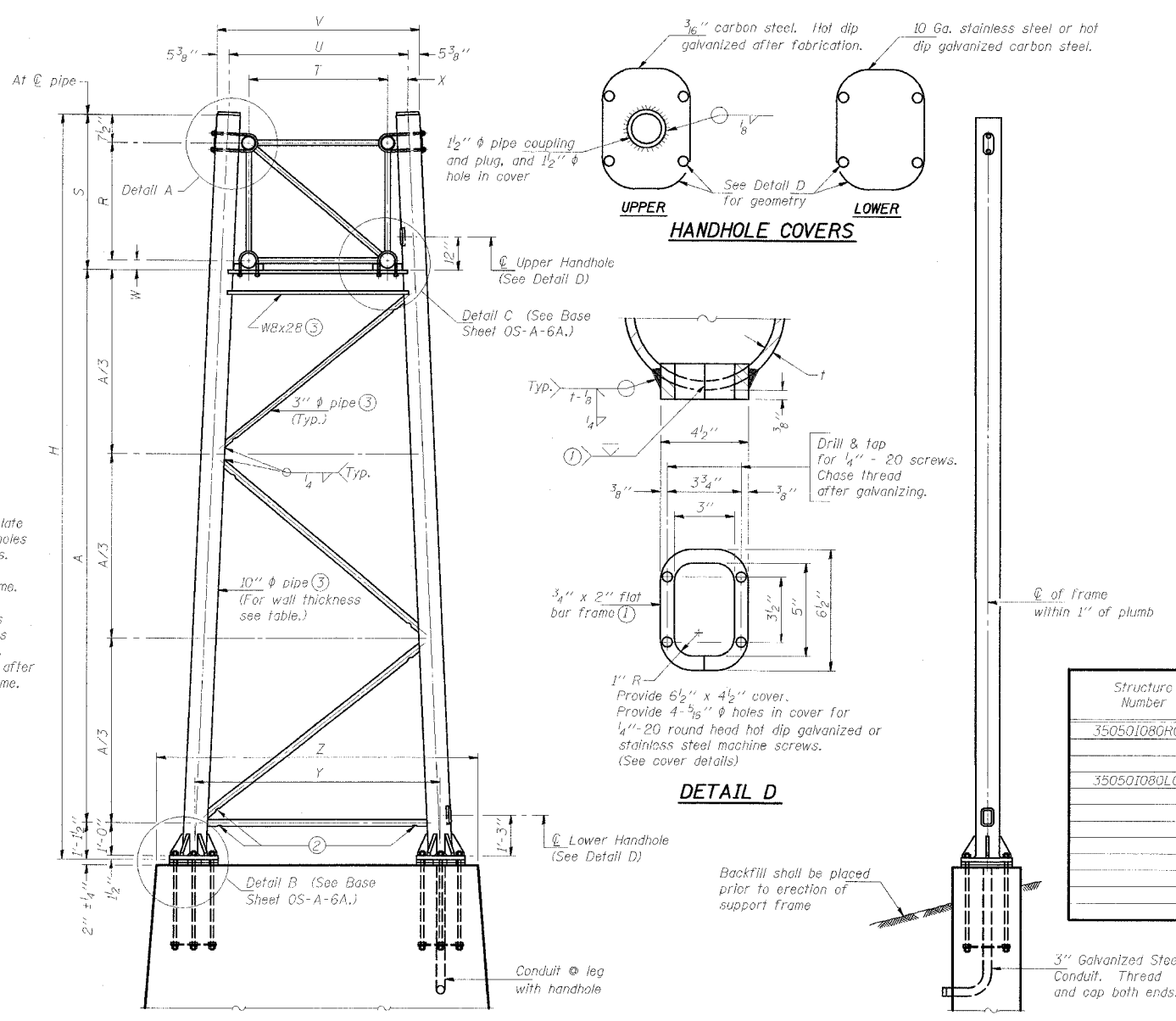

Support Design Loads: See Base Sheet OS-A-1 for design and loading criteria.
Load combinations checked include deadload plus:
a) 100% wind normal to sign, 20% parallel to sign
b) 60% wind normal to sign, 30% parallel to sign

- In lieu of fabricated handhole frame as shown, may cut from 2" plate (rolling direction vertical). All cut faces to be ground to ANSI Roughness of 500 \sqrt{in} or less.
- Galvanizing vent holes of adequate size shall be provided on underside of each end of bracing pipes. Alternately, holes may be provided in wall of pipe column. All vent holes shall be drilled and de-burred. (Typ.)
- Steel pipe, plate, carbon steel handhole covers and rolled sections shall be hot dip galvanized after fabrication. Painting is not permitted. See Base Sheet OS-A-1.
- See General Notes for fasteners.
- Dimensions shown are based on selection criteria in the Sign Structures Manual. Nonstandard applications must have dimensions verified or amended as appropriate.

Structure Number	Station	Support		Truss Type	Pipe Wall Thickness	H	A
		Left	Right				
350501080R076.4	643+14	X	X	I-A	0.365"	28'-3 1/2"	20'-10 3/4"
350501080L077.0	674+70	X	X	I-A	0.365"	29'-0"	22'-5"
				I-A	0.365"	32'-0"	25'-5"

FOR FOUNDATION DETAILS SEE BASE SHEET OS-F3 (Spread Footing) or OS4-F3 (Drilled Shaft).

SIDE ELEVATION

END ELEVATION

10" ϕ PIPE TRUSS SUPPORT FRAME

NUMBER	REVISION	DATE

Truss Type	Dimensions									
	R	S	T	U	V	W	X	Y	Z	
I-A	4'-6"	5'-5 1/2"	4'-0"	5'-6"	6'-4 3/8"	4"	9"	8'-3"	10'-9"	
II-A (3)	5'-3"	6'-3 1/4"	4'-6"	6'-1"	6'-11 3/4"	4 3/4"	9 1/2"	8'-3"	10'-9"	

REVISIONS NAME	DATE

ILLINOIS DEPARTMENT OF TRANSPORTATION
OVERHEAD SIGN STRUCTURES
SUPPORT FRAME FOR ALUMINUM TRUSS
 3S0501080R076.4, STATION 643+14
 3S0501080L077.0, STATION 674+70
 SCALE: NONE DRAWN BY: MES
 DATE: 09/04 CHECKED BY: MTD/FMA