

F.A.P. RTE.	SECTION	COUNTY	TOTAL SHEETS	SHEET NO.
*	2010-004-GRR	McHENRY	16	1
		ILLINOIS	CONTRACT NO. 60K22	

STATE OF ILLINOIS
DEPARTMENT OF TRANSPORTATION
DIVISION OF HIGHWAYS

PROPOSED HIGHWAY PLANS

ROUTE VARIOUS LOCATIONS
SECTION 2010-004-GRR
GUARDRAIL IMPROVEMENTS
PROJECT: HSIP-0005(830)
McHENRY COUNTY
C-91-449-10

FOR INDEX OF SHEETS, SEE SHEET NO. 2

TRAFFIC DATA

IL 176
EXISTING ADT = 7,300 - 12,600 (2007)
SPEED LIMIT = 35 - 45 MPH

IL 23
EXISTING ADT = 5,600 (2007)
SPEED LIMIT = 35-45 MPH

IL 31
EXISTING ADT = 11,200 (2007)
SPEED LIMIT = 55 MPH

IL 47
EXISTING ADT = 8,000-15,500 (2007)
SPEED LIMIT = 40 MPH

IL 22
EXISTING ADT = 16,500 (2007)
SPEED LIMIT = 45 MPH

US 14
EXISTING ADT = 6,300 (2007)
SPEED LIMIT = 45 MPH

THE PROJECT IS LOCATED IN THE CITIES OF CRYSTAL LAKE, HARVARD, MARENGO AND WOODSTOCK AND IN THE VILLAGE OF FOX RIVER GROVE

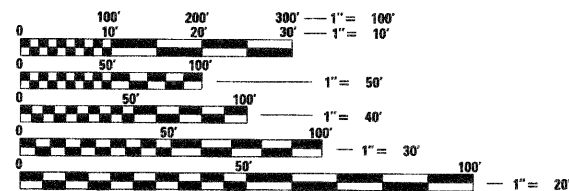

FULL SIZE PLANS HAVE BEEN PREPARED USING STANDARD ENGINEERING SCALES. REDUCED SIZED PLANS WILL NOT CONFORM TO STANDARD SCALES. IN MAKING MEASUREMENTS ON REDUCED PLANS, THE ABOVE SCALES MAY BE USED.

J.U.L.I.E.
JOINT UTILITY LOCATION INFORMATION FOR EXCAVATION
1-800-892-0123
OR 811

PROJECT ENGINEER: PETER JOHNSTON (GRAEF) 773-399-0112
PROJECT MANAGER: KEN ENG (IDOT) 847-705-4247

CONTRACT NO. 60K22

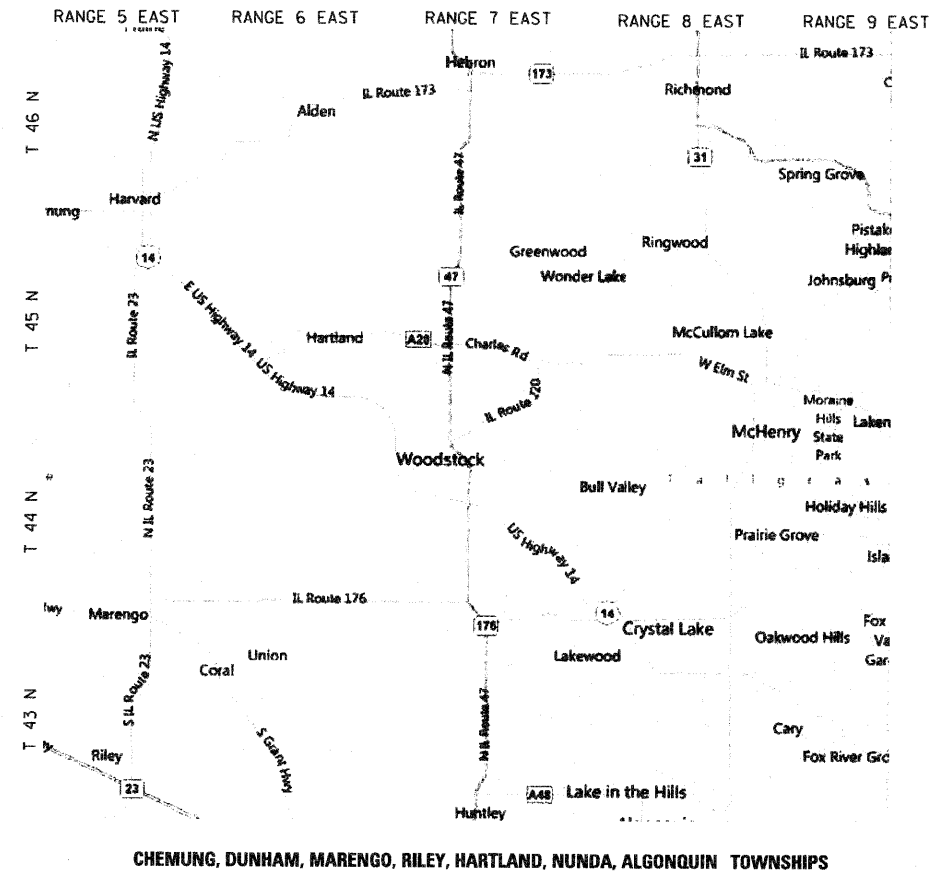

PETER M. JOHNSTON
REGISTERED PROFESSIONAL ENGINEER OF ILLINOIS
10-25-10
11-30-11

STATE OF ILLINOIS
DEPARTMENT OF TRANSPORTATION
DIVISION OF HIGHWAYS

SUBMITTED OCTOBER 26 20 10

Diana M. O'Keefe DEPUTY DIRECTOR OF HIGHWAYS, REGION ENGINEER
December 10 20 10
Scott E. Stitt, P.E. acting ENGINEER OF DESIGN AND ENVIRONMENT
December 10 20 10
Christine M. Reed DIRECTOR OF HIGHWAYS, CHIEF ENGINEER

PRINTED BY THE AUTHORITY OF THE STATE OF ILLINOIS

GRAEF 8501 W. Higgins Road, Suite 280
Chicago, Illinois 60631
(773) 399-0112

INDEX OF SHEETS

SHEET NO.	DESCRIPTION
1	COVER SHEET
2	INDEX, HIGHWAY STANDARDS, AND GENERAL NOTES
3	SUMMARY OF QUANTITIES
4	LOCATION MAP
5-11	ROADWAY PLAN
12-13	HEADWALL DETAILS
14	WINGWALL DETAILS
15	DETAILS FOR DEPRESSED CURB AND GUTTER AND SHOULDER TREATMENT AT TBT TY 1 SPL (BD34)
16	ARTERIAL ROAD INFORMATION SIGNING (TC22)

HIGHWAY STANDARDS

STD. NO.	TITLE
630001-09	STEEL PLATE BEAM GUARDRAIL
630101-09	GUARDRAIL MOUNTED ON EXISTING CULVERTS
630201-00	PCC/HMA STABILIZATION AT STEEL PLATE BEAM GUARDRAIL
630301-05	SHOULDER WIDENING FOR TYPE 1 (SPECIAL) GUARDRAIL TERMINALS
631031-09	TRAFFIC BARRIER TERMINAL TYPE 6
635006-03	REFLECTOR AND TERMINAL MARKER PLACEMENT
635011-02	REFLECTOR MARKER AND MOUNTING DETAILS
701006-03	OFF-ROAD OPERATIONS, 2L, 2W, 15' (4.5 m) TO 24" (600 mm) FROM PAVEMENT EDGE
701101-02	OFF-ROAD OPERATIONS, MULTILANE, 15' (4.5 m) TO 24" (600 mm) FROM PAVEMENT EDGE
701326-04	LANE CLOSURE, 2L, 2W, PAVEMENT WIDENING, FOR SPEEDS ≥ 45 MPH
701422-03	LANE CLOSURE, MULTILANE, FOR SPEEDS ≥ 45 MPH TO 55 MPH
701901-01	TRAFFIC CONTROL DEVICES

GENERAL NOTES

- BEFORE STARTING ANY EXCAVATION, THE CONTRACTOR SHALL CALL "J.U.L.I.E." AT 800-892-0123 OR "CUAN" (CHICAGO UTILITY ALERT NETWORK), 312-744-7000 FOR FIELD LOCATIONS OF BURIED ELECTRIC, TELEPHONE AND GAS FACILITIES (48 HOUR NOTIFICATION IS REQUIRED).
- THE CONTRACTOR SHALL COORDINATE CONSTRUCTION ACTIVITIES WITH UTILITY COMPANIES AND LOCAL AGENCIES.
- THE CONTRACTOR WILL NOT BE ALLOWED TO SET UP A YARD OR FIELD OFFICE ON STATE PROPERTY WITHOUT WRITTEN PERMISSION FROM THE DEPARTMENT.
- THE RESIDENT ENGINEER SHALL CONTACT THE TRAFFIC CONTROL SUPERVISOR AT (847) 705-4470 A MINIMUM 72 HOURS PRIOR TO THE PLACEMENT OF ANY TEMPORARY TRAFFIC CONTROL DEVICES.
- WHEN GUARDRAIL POSTS ARE PLACED BEHIND CONCRETE HEADWALLS, THE POSTS SHALL NOT BE PLACED TO BLOCK THE DRAINAGE OPENING.

FILE NAME =	USER NAME = .USER.	DESIGNED - EF	REVISED	STATE OF ILLINOIS DEPARTMENT OF TRANSPORTATION	GUARDRAIL IMPROVEMENTS - McHENRY COUNTY		F.A. RTE.	SECTION	COUNTY	TOTAL SHEETS	SHEET NO.
#FILE#	PLOT SCALE = 50.0000' / IN.	DRAWN - EF	REVISED		INDEX OF SHEETS, HIGHWAY STANDARDS, AND GENERAL NOTES		*	2010-004-GRR	McHENRY	16	2
	PLOT DATE = 10/25/2010	CHECKED - RS	REVISED		SCALE: 50	SHEET NO. 1 OF 1 SHEETS	STA.	TO STA.	CONTRACT NO. 60K22		
		DATE 10/25/10	REVISED		ILLINOIS FED. AID PROJECT						

SUMMARY OF QUANTITIES

URBAN
90% FED.
10% STATE

PAY ITEM NUMBER	DESCRIPTION	UNIT	TOTAL QUANTITY	0021 SAFETY
20200600	EXCAVATING AND GRADING EXISTING SHOULDER	UNIT	35	35
21101615	TOPSOIL FURNISH AND PLACE, 4"	SQ YD	1,536	1,536
25000210	SEEDING, CLASS 2A	ACRE	0.32	0.32
25000400	NITROGEN FERTILIZER NUTRIENT	POUND	29	29
25000500	PHOSPHORUS FERTILIZER NUTRIENT	POUND	29	29
25000600	POTASSIUM FERTILIZER NUTRIENT	POUND	29	29
25100630	EROSION CONTROL BLANKET	SQ YD	1,536	1,536
48101620	AGGREGATE SHOULDERS, TYPE B 10"	SQ YD	2,734	2,734
50102400	CONCRETE REMOVAL	CU YD	4	4
50104000	BRIDGE RAIL REMOVAL	FOOT	56	56
50300255	CONCRETE SUPERSTRUCTURE	CU YD	10	10
50800205	REINFORCEMENT BARS, EPOXY COATED	POUND	5,950	5,950
63000001	STEEL PLATE BEAM GUARD RAIL, TYPE A 6 FOOT POSTS	FOOT	288	288
63000025	STEEL PLATE BEAM GUARD RAIL, ATTACHED TO STRUCTURES	FOOT	163	163
63100085	TRAFFIC BARRIER TERMINAL, TYPE 6	EACH	8	8
63100167	TRAFFIC BARRIER TERMINAL, TYPE 1 (SPECIAL) TANGENT	EACH	48	48
63200310	GUARDRAIL REMOVAL	FOOT	2,941	2,941
63301000	REMOVE AND REERECT STEEL PLATE BEAM GUARD RAIL	FOOT	88	88
63301990	REMOVE AND REERECT TRAFFIC BARRIER TERMINALS, TYPE 1	EACH	3	3
67000400	ENGINEER'S FIELD OFFICE, TYPE A	CAL MO	6	6
67100100	MOBILIZATION	L SUM	1	1
70100500	TRAFFIC CONTROL AND PROTECTION, STANDARD 701326	L SUM	1	1
78200420	GUARDRAIL MARKERS, TYPE B	EACH	123	123
78201000	TERMINAL MARKER-DIRECT APPLIED	EACH	48	48
X0322194	POLYMER MODIFIED PORTLAND CEMENT MORTAR	SQ FT	9	9
Δ X2503100	MOWING	UNIT	138	138
Z0030030	IMPACT ATTENUATORS (FULLY REDIRECTIVE, NARROW), TEST LEVEL 3	EACH	3	3
Z0030850	TEMPORARY INFORMATION SIGNING	SQ FT	154	154

* DENOTES SPECIALTY ITEM

Δ NON-PARTICIPATING

FILE NAME *	USER NAME * .USER_	DESIGNED - EF	REVISED -	STATE OF ILLINOIS DEPARTMENT OF TRANSPORTATION	GUARDRAIL IMPROVEMENTS - McHENRY COUNTY SUMMARY OF QUANTITIES		F.A. RTE.	SECTION	COUNTY	TOTAL SHEETS	SHEET NO.
FILEL		DRAWN - EF	REVISED -				*	2010-004-GRR	McHENRY	16	3
		CHECKED - RS	REVISED -				SCALE: 50		SHEET NO. 1 OF 1 SHEETS		STA.
		DATE - 10/25/10	REVISED -	ILLINOIS FED. AID PROJECT							

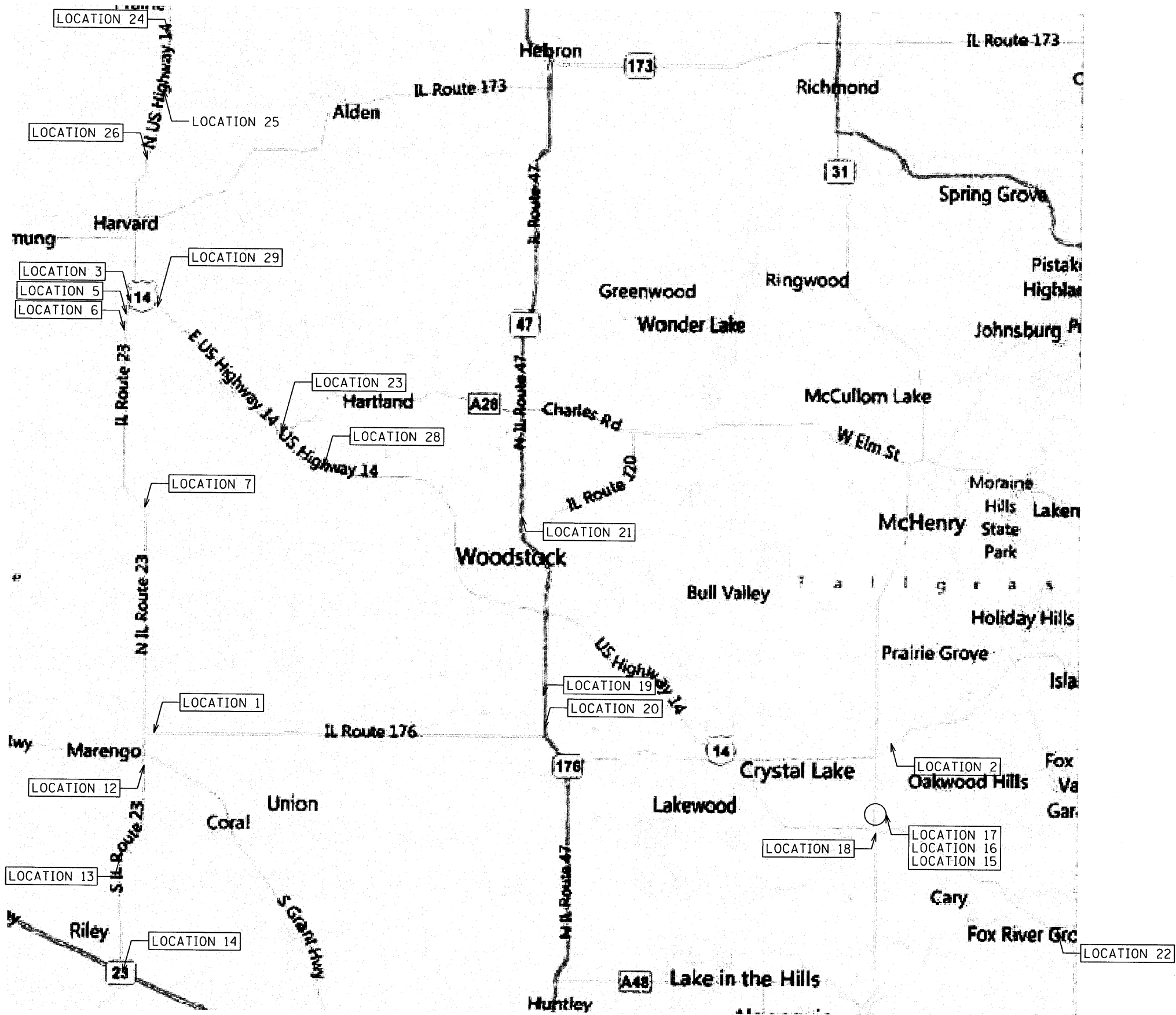

FILE NAME =	USER NAME = .USER.	DESIGNED - EF	REVISED -	STATE OF ILLINOIS DEPARTMENT OF TRANSPORTATION	GUARDRAIL IMPROVEMENTS - McHENRY COUNTY LOCATION MAP			F.A. RTE.	SECTION	COUNTY	TOTAL SHEETS	SHEET NO.
*FILEL4		DRAWN - EF	REVISED -		SCALE: 50	SHEET NO. 1 OF 1 SHEETS	STA.	TO STA.	2010-004-GRR	McHENRY	16	4
		CHECKED - RS	REVISED -		CONTRACT NO. 60K22							
		DATE - 10/25/10	REVISED -		ILLINOIS FED. AID PROJECT							

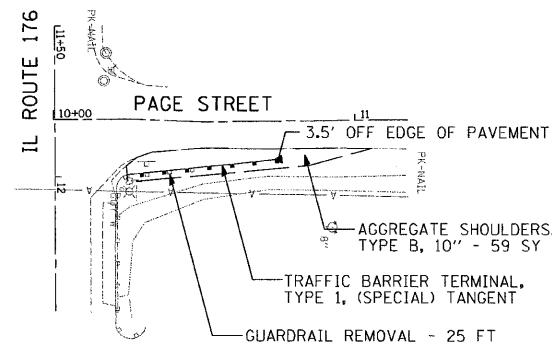

LOCATION 1

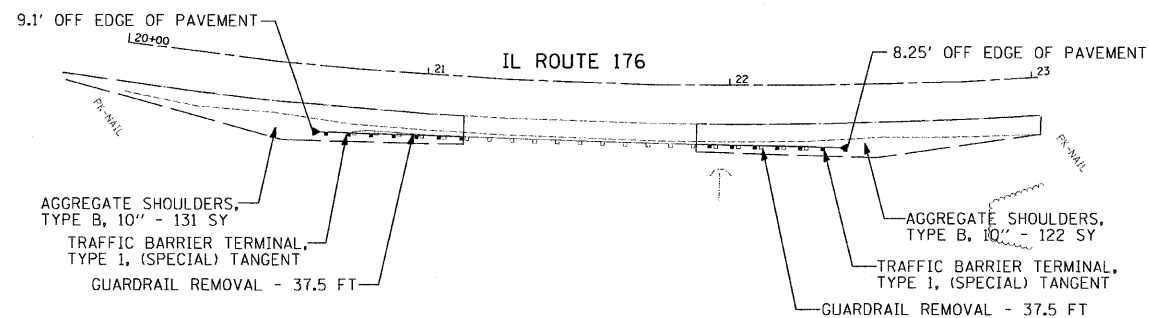

LOCATION 2

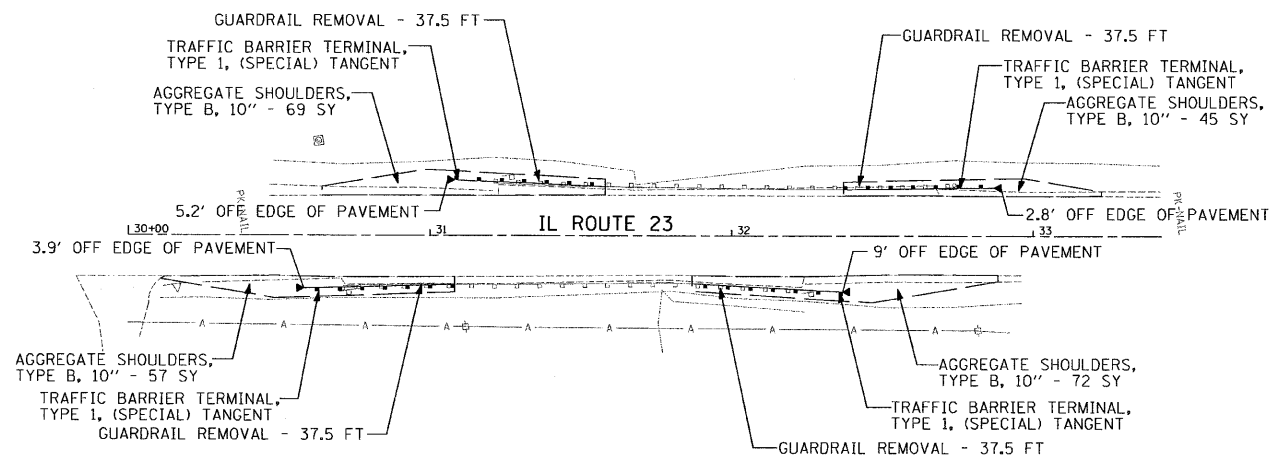

LOCATION 3 AND 4

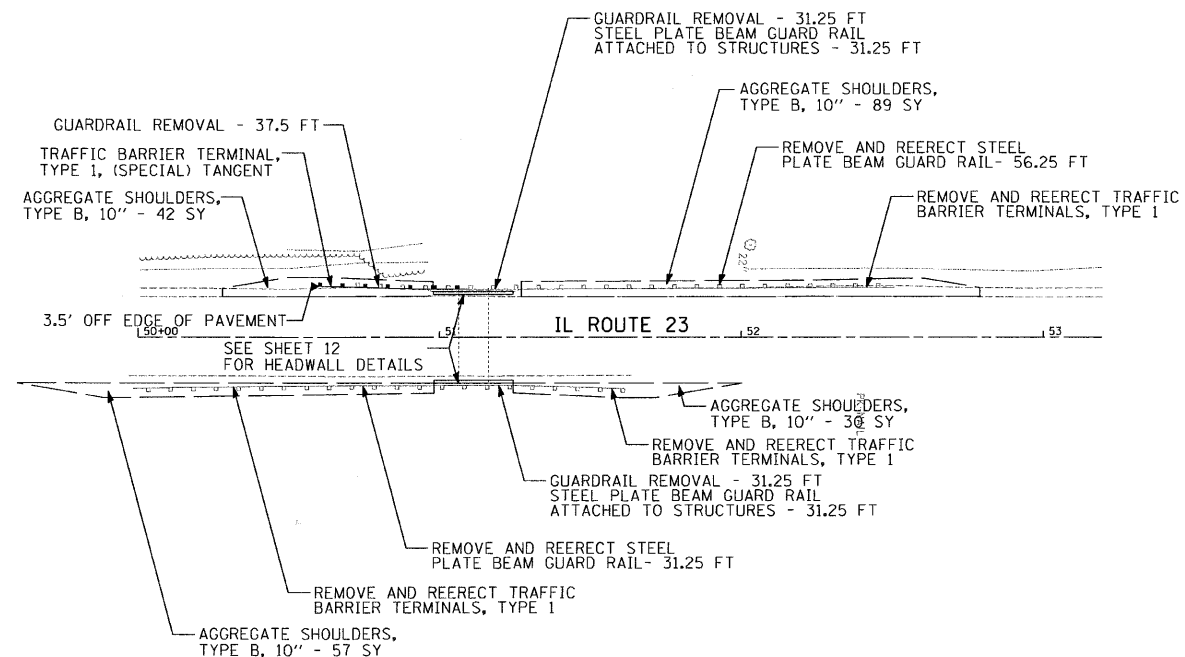

LOCATION 5

n:\jbs2009\2009\3023-41\CAD\Site\dgn\001\60K22-ent-plan01.dgn
 10/25/2010 1:29:06 PM

FILE NAME = #FILE#	USER NAME = .USER.	DESIGNED - EAF	REVISED -
		DRAWN - EAF	REVISED -
	PLOT SCALE = 30.0000' / IN.	CHECKED - RS	REVISED -
	PLOT DATE = 10/25/2010	DATE - 10/25/10	REVISED -

STATE OF ILLINOIS
DEPARTMENT OF TRANSPORTATION

GUARDRAIL IMPROVEMENTS - McHENRY COUNTY
ROADWAY PLANS

SCALE: 30 SHEET NO. 1 OF 7 SHEETS STA. TO STA.

F.A. RTE.	SECTION	COUNTY	TOTAL SHEETS	SHEET NO.
*	2010-004 GRR	McHENRY	16	5
* VARIOUS ROUTES			CONTRACT NO. 60K22	
ILLINOIS FED. AID PROJECT				

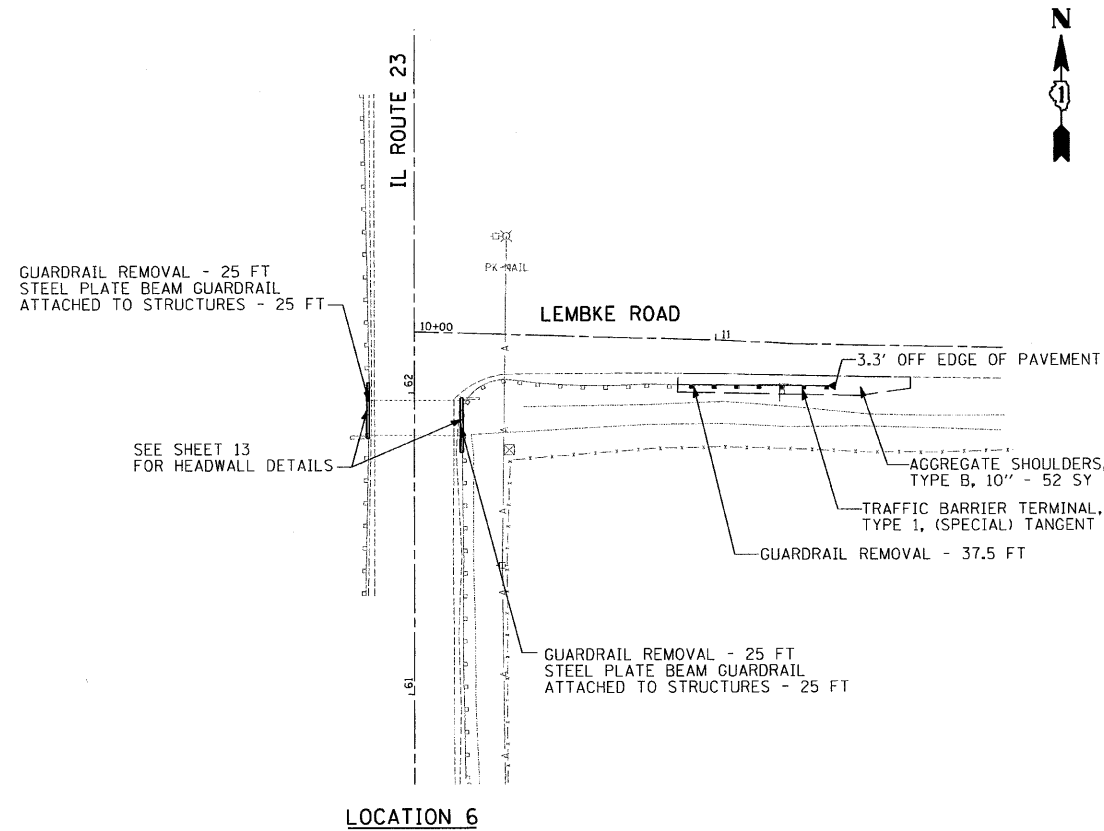

LOCATION 6

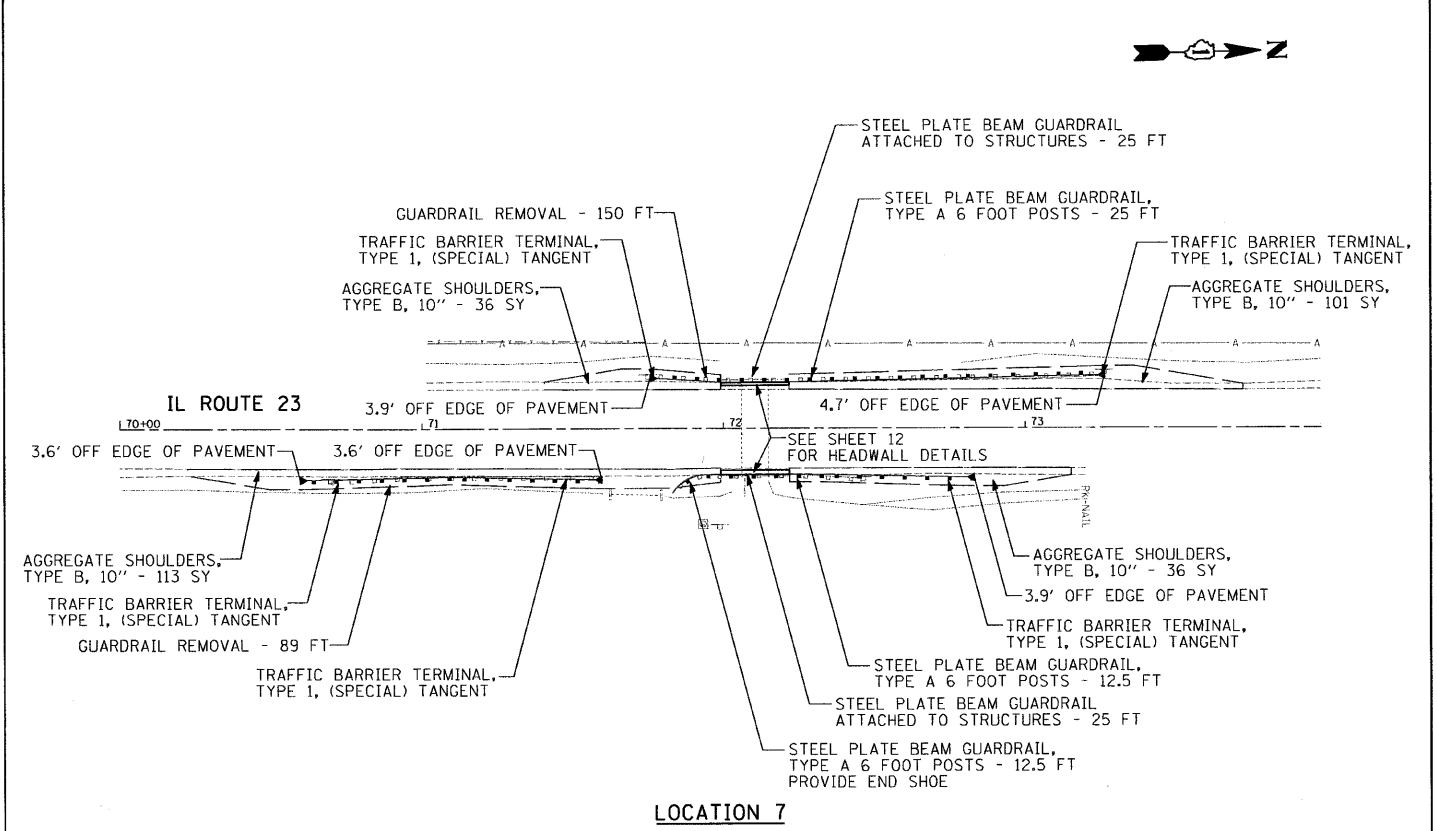

LOCATION 7

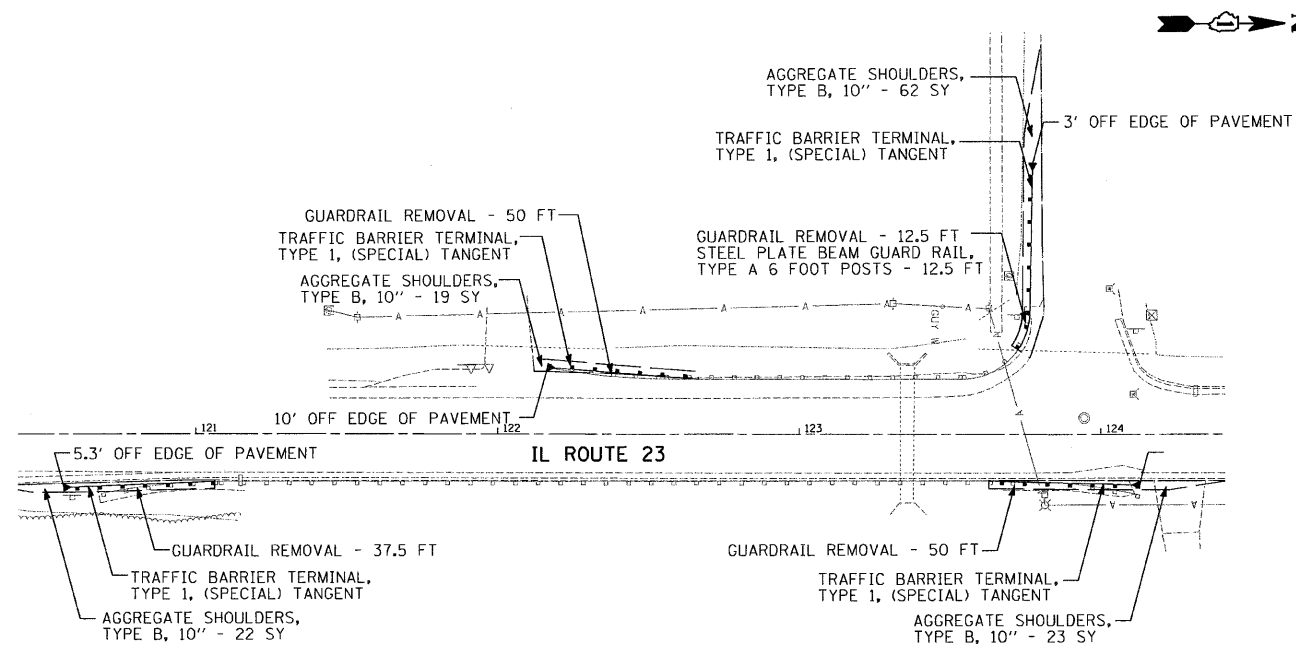

LOCATION 12

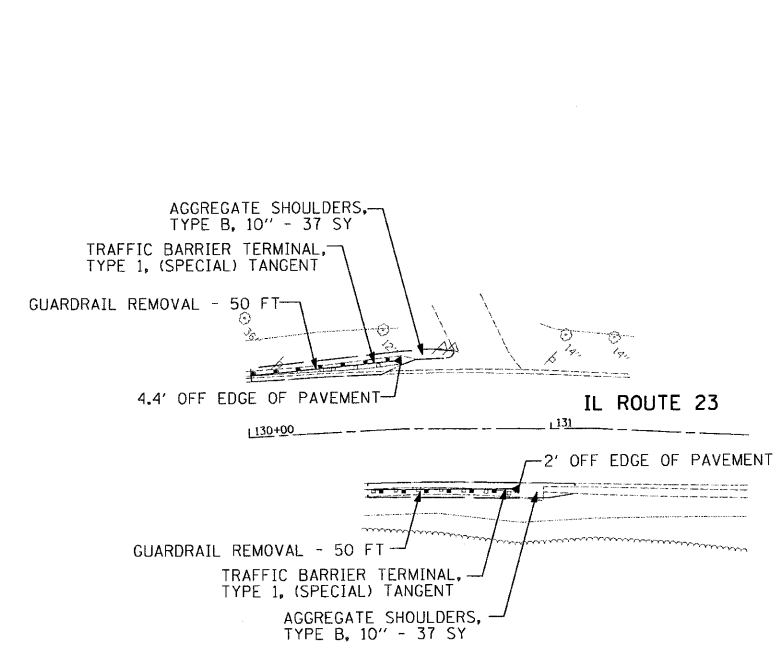

LOCATION 13

F:\jobs\2009\20091023-41\CAD\Site\ dgn\00\160K22-sht-plan02.dgn
 10/25/2010 1:29:11 PM

FILE NAME =	USER NAME = .USER.	DESIGNED - EAF	REVISED -
#FILE#		DRAWN - EAF	REVISED -
	PLOT SCALE = 30.0000' / IN.	CHECKED - RS	REVISED -
	PLOT DATE = 10/25/2010	DATE - 10/25/10	REVISED -

STATE OF ILLINOIS
DEPARTMENT OF TRANSPORTATION

GUARDRAIL IMPROVEMENTS - McHENRY COUNTY
ROADWAY PLANS

SCALE: 30 SHEET NO. 2 OF 7 SHEETS STA. TO STA.

F.A. RTE.	SECTION	COUNTY	TOTAL SHEETS	SHEET NO.
•	2010-004 GRR	McHENRY	16	6
• VARIOUS ROUTES			CONTRACT NO. 60K22	
ILLINOIS FED. AID PROJECT				

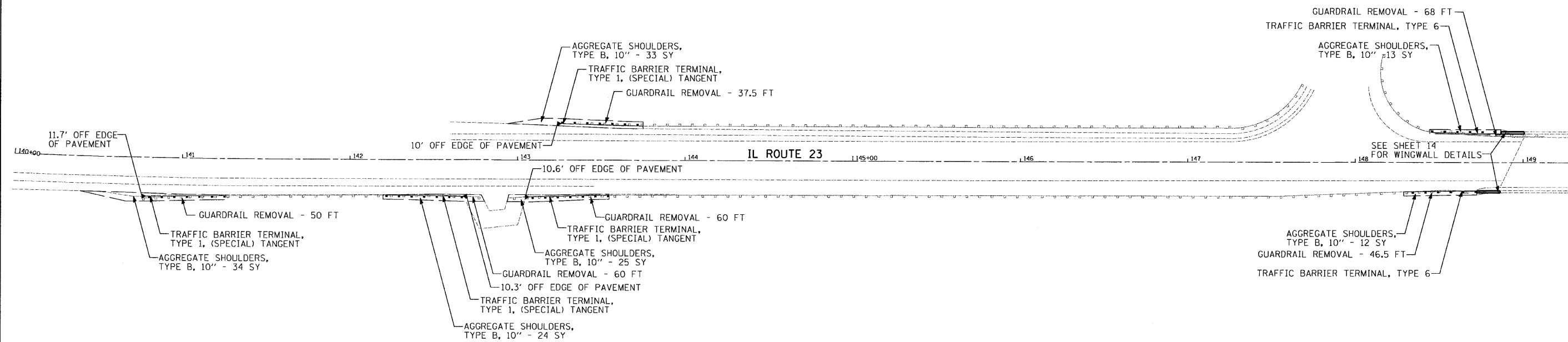

LOCATION 14

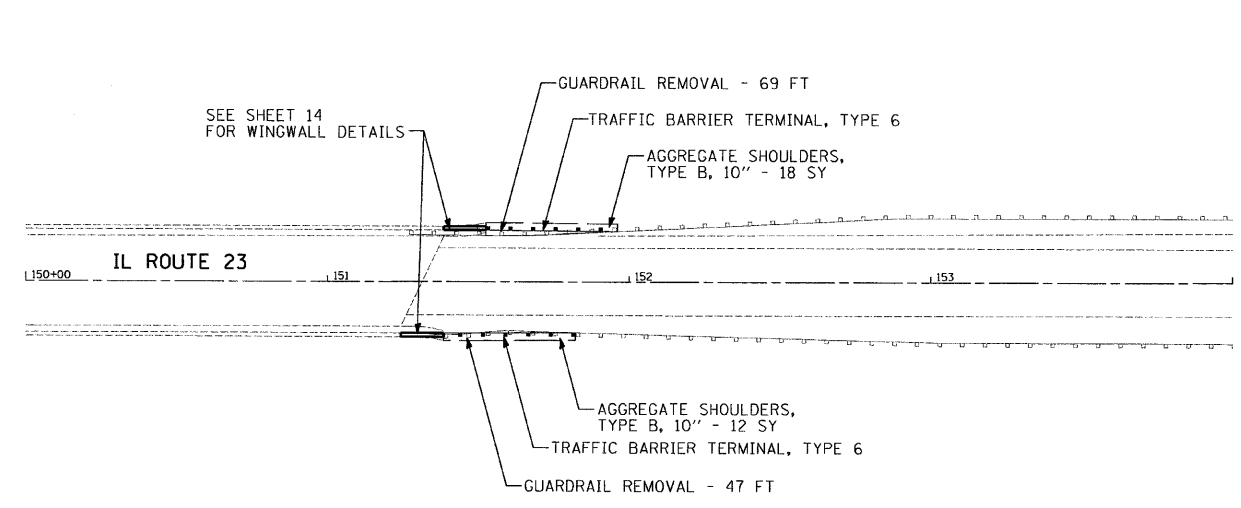

LOCATION 14

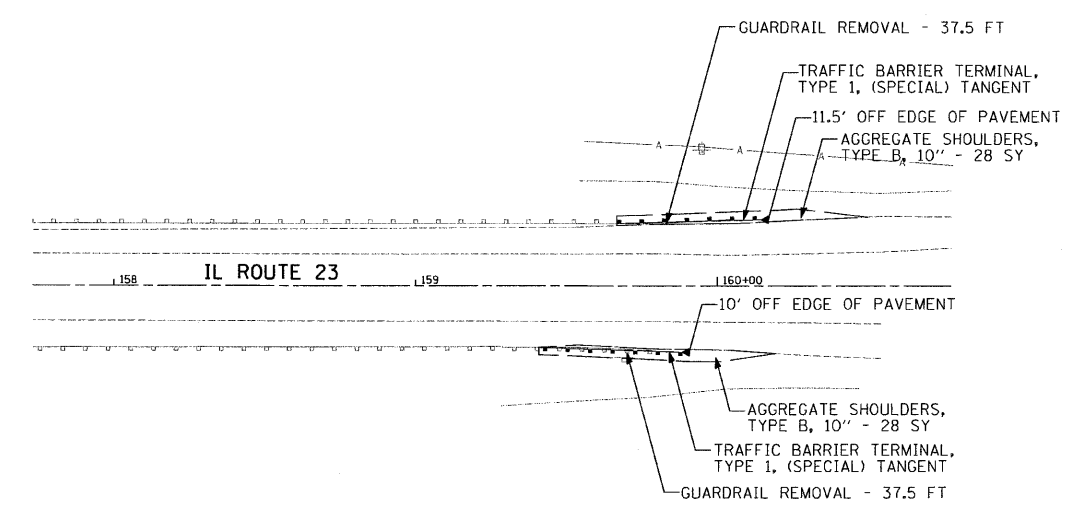
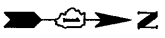

LOCATION 14

h:\jobs\2009\20093023-41\CAD\Site\dgn\00\160K22-sht-plan03.dgn
10/25/2010 1:29:18 PM

FILE NAME =	USER NAME = .USER.	DESIGNED - EAF	REVISED -
#FILE#		DRAWN - EAF	REVISED -
	PLOT SCALE = 30.0010' / IN.	CHECKED - RS	REVISED -
	PLOT DATE = 10/25/2010	DATE - 10/25/10	REVISED -

**STATE OF ILLINOIS
DEPARTMENT OF TRANSPORTATION**

GUARDRAIL IMPROVEMENTS - McHENRY COUNTY ROADWAY PLANS			
SCALE: 30	SHEET NO. 3 OF 7 SHEETS	STA.	TO STA.

F.A. RTE.	SECTION	COUNTY	TOTAL SHEETS	SHEET NO.
	2010-004 GRR	McHENRY	16	7
VARIOUS ROUTES			CONTRACT NO. 60K22	
ILLINOIS FED. AID PROJECT				

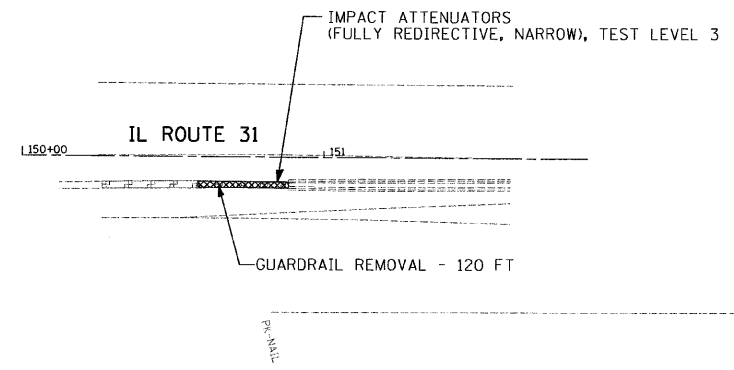

LOCATION 15

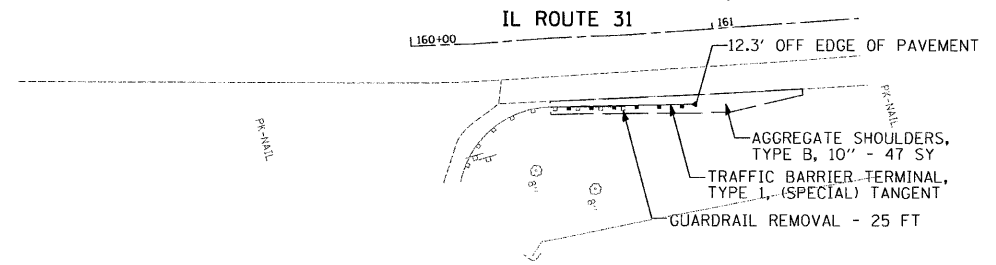

LOCATION 16

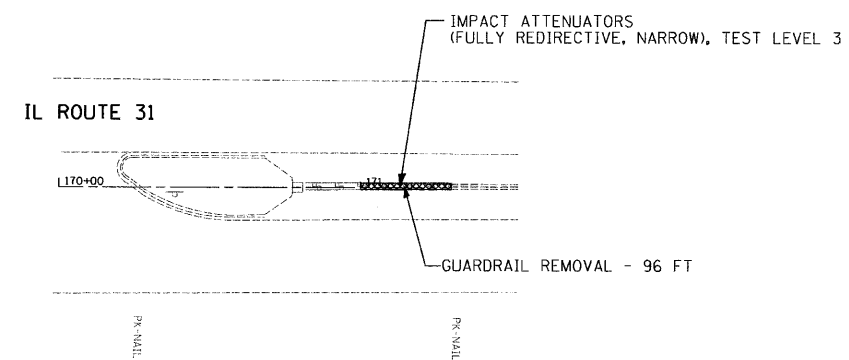
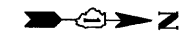

LOCATION 17

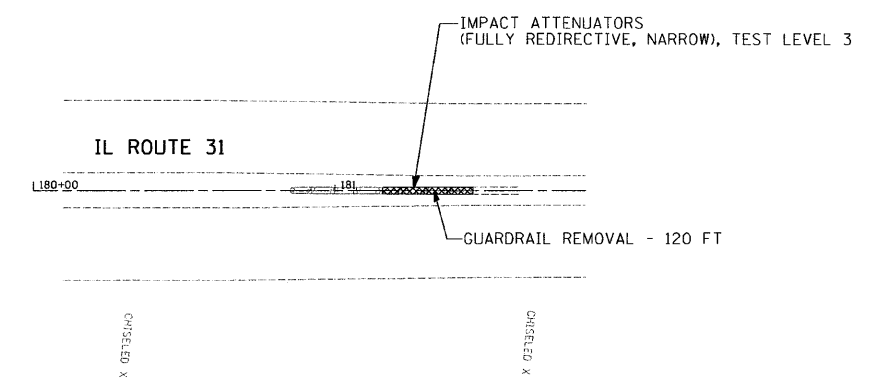

LOCATION 18

h:\jbbz009\20093023-41\CAD\Site\dm\00\180x22-sh1-plan04.dgn
10/25/2010 1:29:23 PM

FILE NAME =	USER NAME = .USER.	DESIGNED - EAF	REVISED -
#FILE#		DRAWN - EAF	REVISED -
	PLOT SCALE = 30.0000' / IN.	CHECKED - RS	REVISED -
	PLOT DATE = 10/25/2010	DATE - 10/25/10	REVISED -

**STATE OF ILLINOIS
DEPARTMENT OF TRANSPORTATION**

**GUARDRAIL IMPROVEMENTS - McHENRY COUNTY
ROADWAY PLANS**

SCALE: 30 SHEET NO. 4 OF 7 SHEETS STA. TO STA.

F.A. RTE.	SECTION	COUNTY	TOTAL SHEETS	SHEET NO.
*	2010-004 GRR	McHENRY	16	8
* VARIOUS ROUTES			CONTRACT NO. 60K22	
ILLINOIS FED. AID PROJECT				

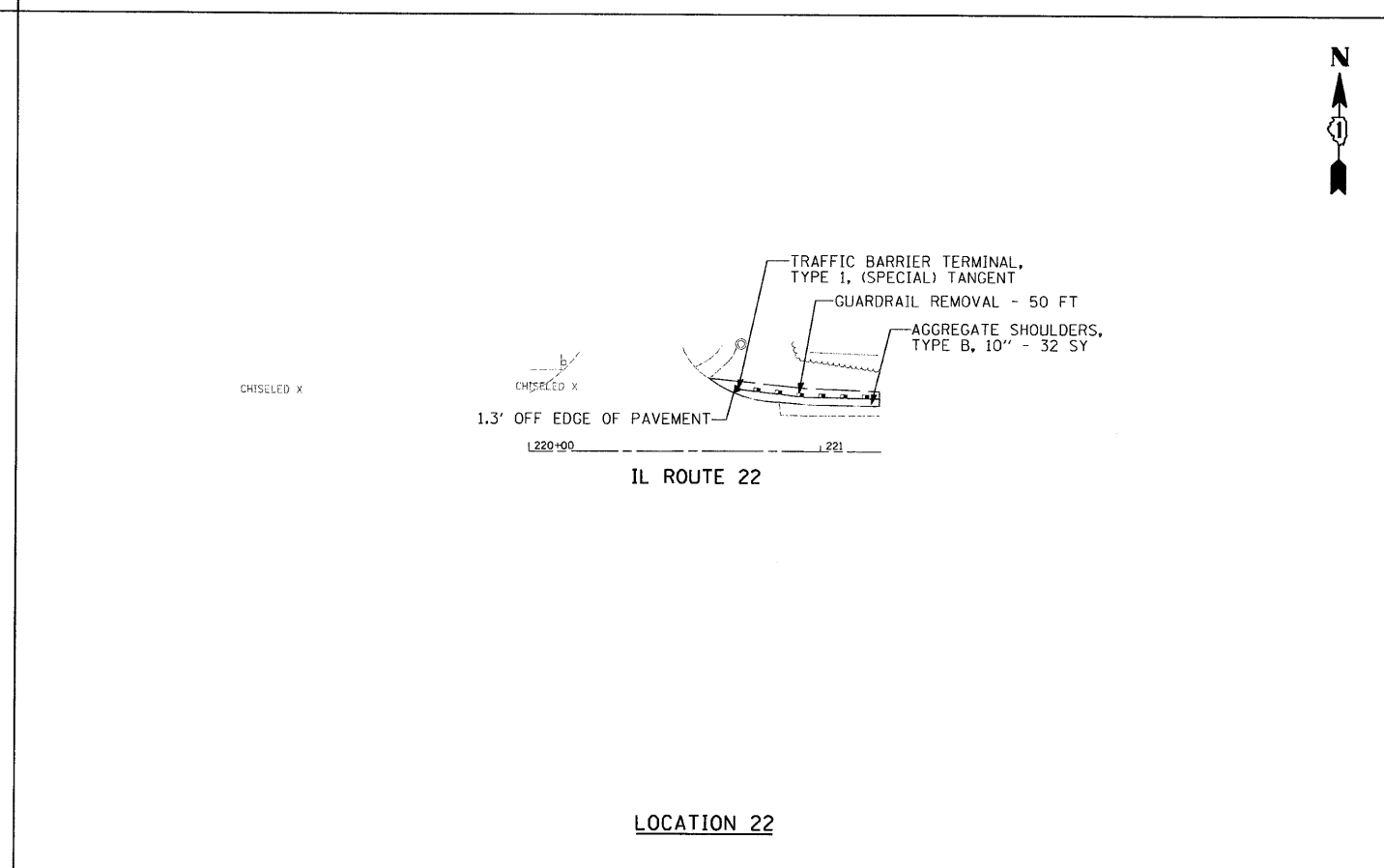
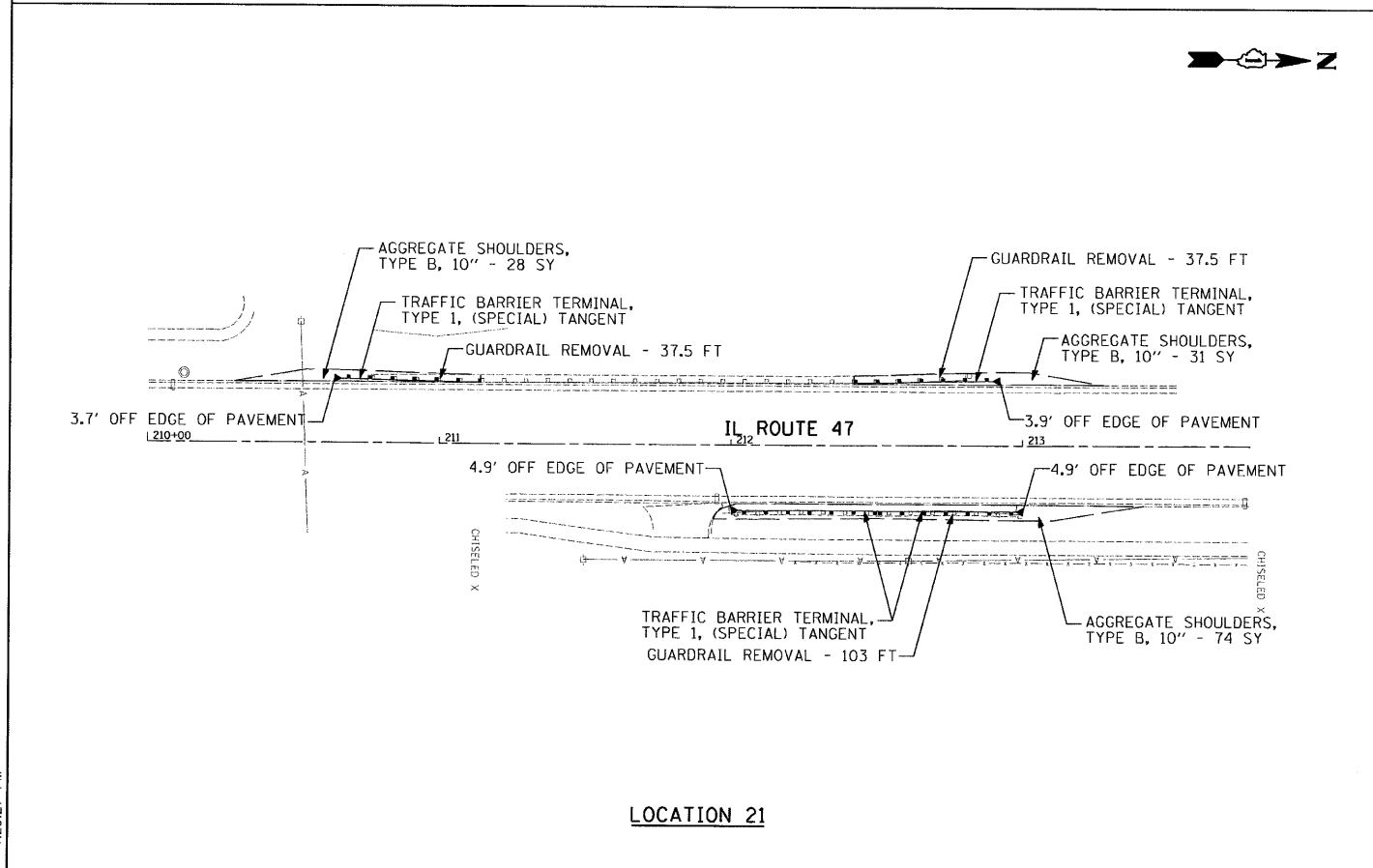
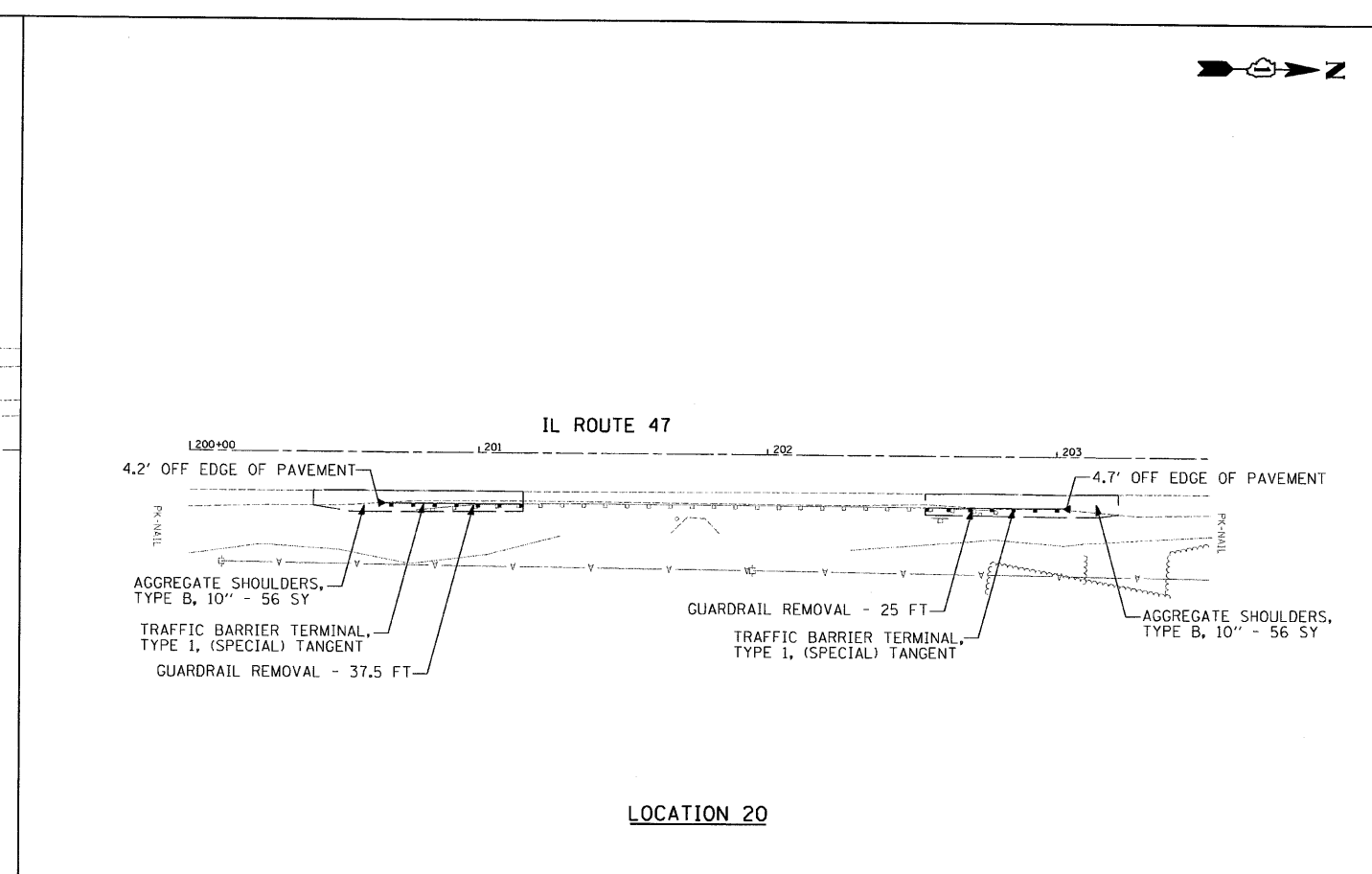
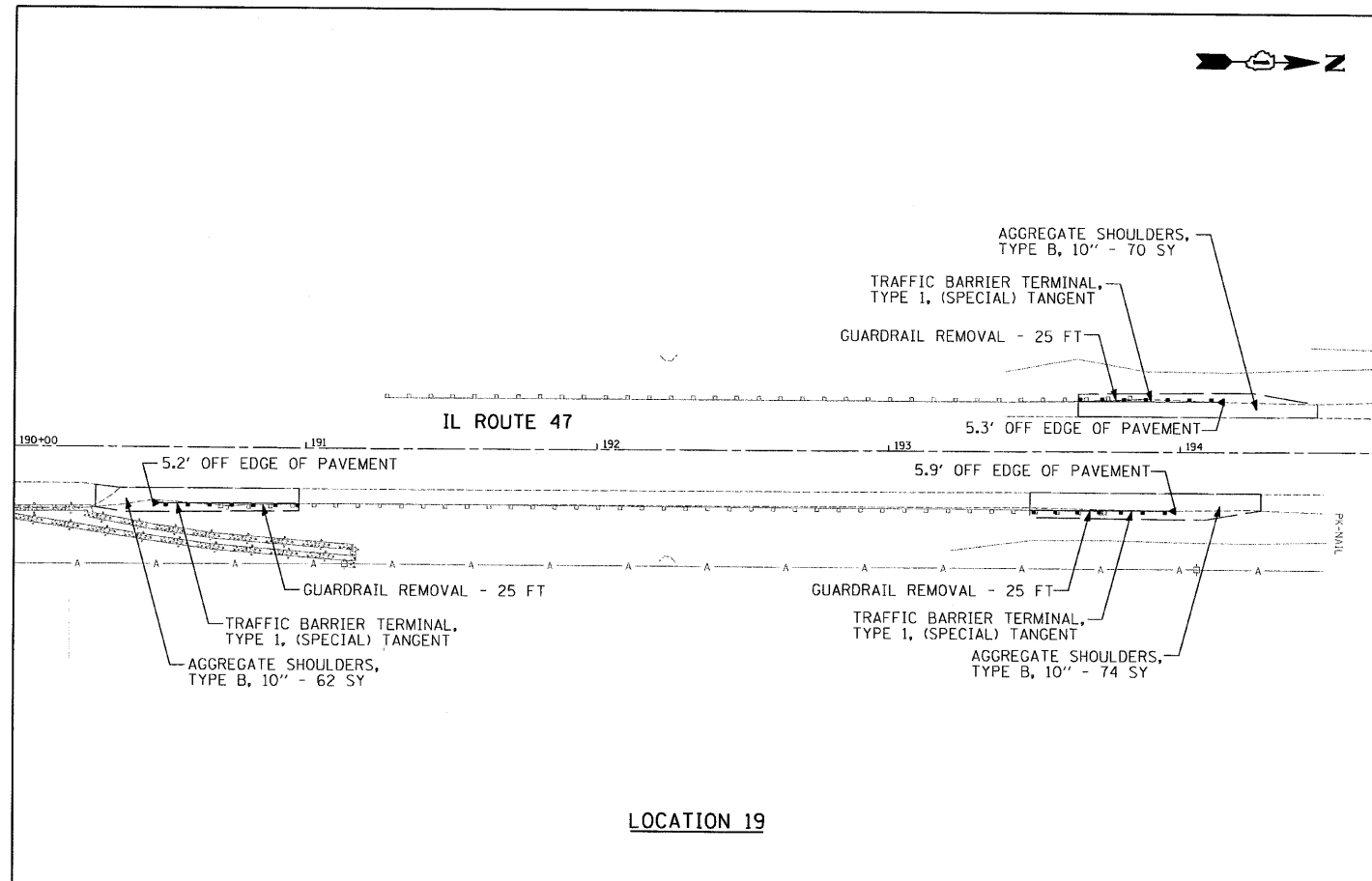

h:\jobs\2009\20093023-41\CAD\Site\Site\00\160K22-snt-plan05.dgn
 10/25/2010 1:29:27 PM

FILE NAME =	USER NAME = .USER.	DESIGNED - EAF	REVISED -
#FILE#		DRAWN - EAF	REVISED -
	PLOT SCALE = 30.0000' / IN.	CHECKED - RS	REVISED -
	PLOT DATE = 10/25/2010	DATE - 10/25/10	REVISED -

STATE OF ILLINOIS
DEPARTMENT OF TRANSPORTATION

GUARDRAIL IMPROVEMENTS - McHENRY COUNTY
ROADWAY PLANS

SCALE: 30 SHEET NO. 5 OF 7 SHEETS STA. TO STA.

F.A. RTE.	SECTION	COUNTY	TOTAL SHEETS	SHEET NO.
*	2010-004 GRR	McHENRY	16	9
* VARIOUS ROUTES			CONTRACT NO. 60K22	
ILLINOIS FED. AID PROJECT				

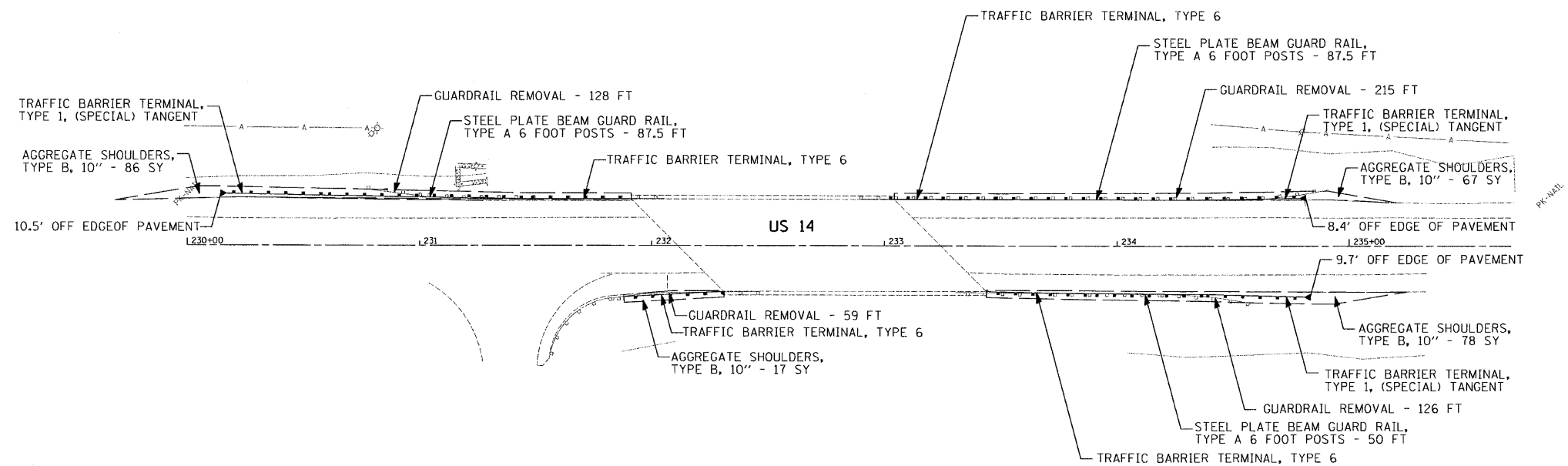
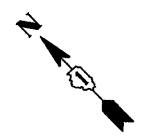

LOCATION 23

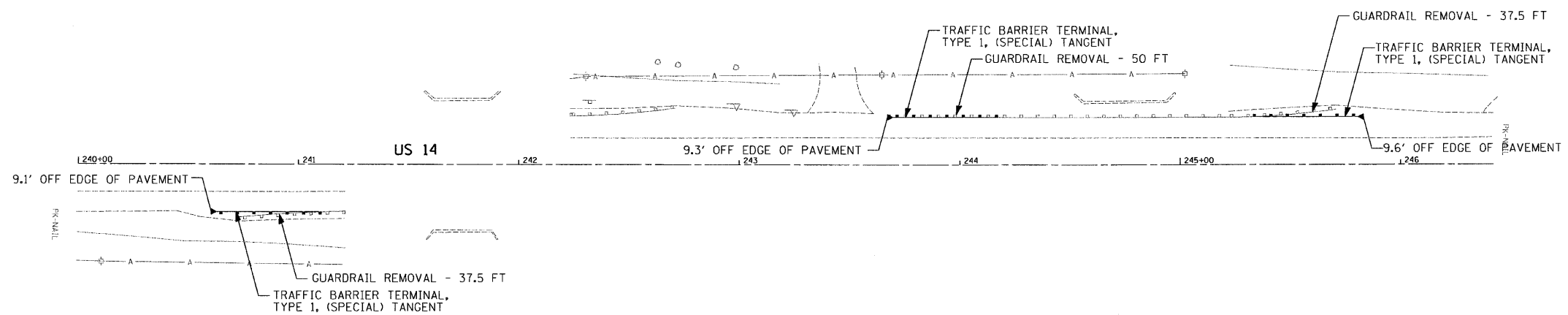

LOCATION 24

r:\jbs\2009\20093023-41\CAD\Site\edgn\00\160x22-sht-plan06.dgn
 10/25/2010 1:29:33 PM

FILE NAME = \$FILEL\$	USER NAME = .USER	DESIGNED - EAF	REVISED -	STATE OF ILLINOIS DEPARTMENT OF TRANSPORTATION	GUARDRAIL IMPROVEMENTS - McHENRY COUNTY ROADWAY PLANS			F.A. RTE.	SECTION	COUNTY	TOTAL SHEETS	SHEET NO.	
	PLOT SCALE = 30,000' / IN.	DRAWN - EAF	REVISED -		SCALE: 30	SHEET NO. 6 OF 7 SHEETS	STA.	TO STA.	2010-004 GRR	McHENRY	16	10	
	PLOT DATE = 10/25/2010	CHECKED - RS	REVISED -						VARIOUS ROUTES				
		DATE - 10/25/10	REVISED -						ILLINOIS FED. AID PROJECT CONTRACT NO. 60K22				

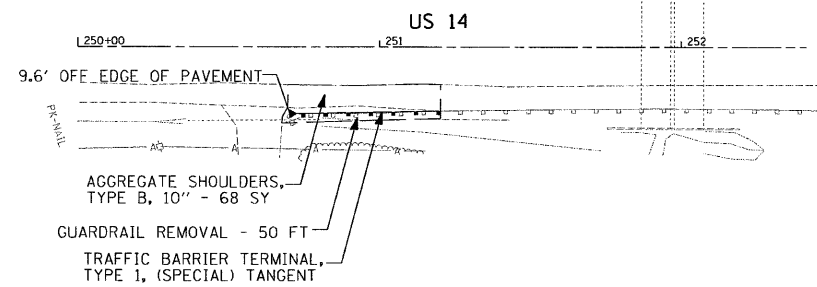

LOCATION 25

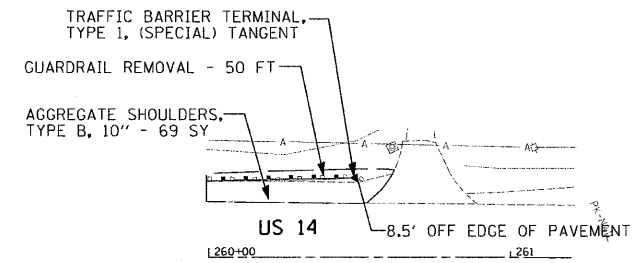

LOCATION 26

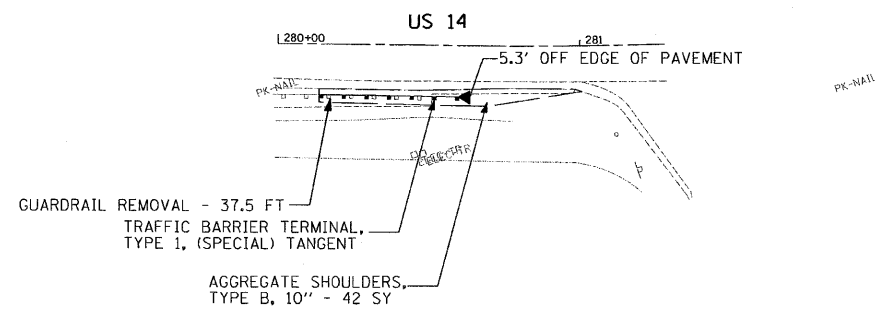

LOCATION 28

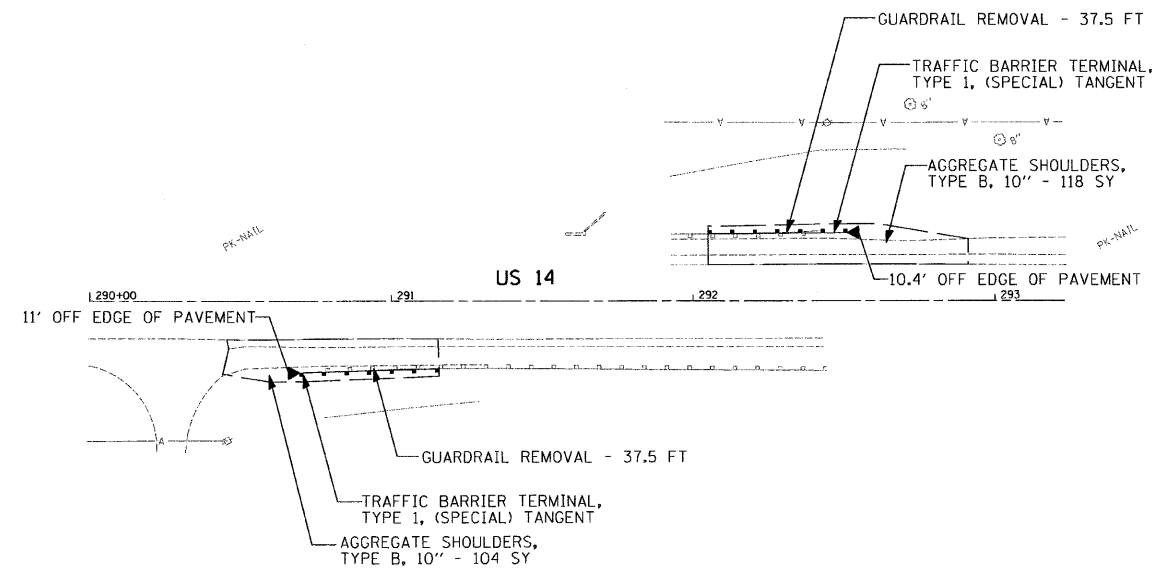

LOCATION 29

h:\jbs\2009\20093023-41\CAD\Site\ dgn\00\160k22-smt-plan07.dgn 10/25/2010 1:29:38 PM

FILE NAME = #FILEL*	USER NAME = .USER	DESIGNED - EAF	REVISED -
		DRAWN - EAF	REVISED -
	PLOT SCALE = 30.0031' / IN.	CHECKED - RS	REVISED -
	PLOT DATE = 10/25/2010	DATE - 10/25/10	REVISED -

**STATE OF ILLINOIS
DEPARTMENT OF TRANSPORTATION**

**GUARDRAIL IMPROVEMENTS - McHENRY COUNTY
ROADWAY PLANS**

SCALE: 30 SHEET NO. 7 OF 7 SHEETS STA. TO STA.

F.A. RTE.	SECTION	COUNTY	TOTAL SHEETS	SHEET NO.
*	2010-004 GRR	McHENRY	16	11
* VARIOUS ROUTES			CONTRACT NO. 60K22	
[ILLINOIS] FED. AID PROJECT				

STATE OF ILLINOIS
DEPARTMENT OF TRANSPORTATION

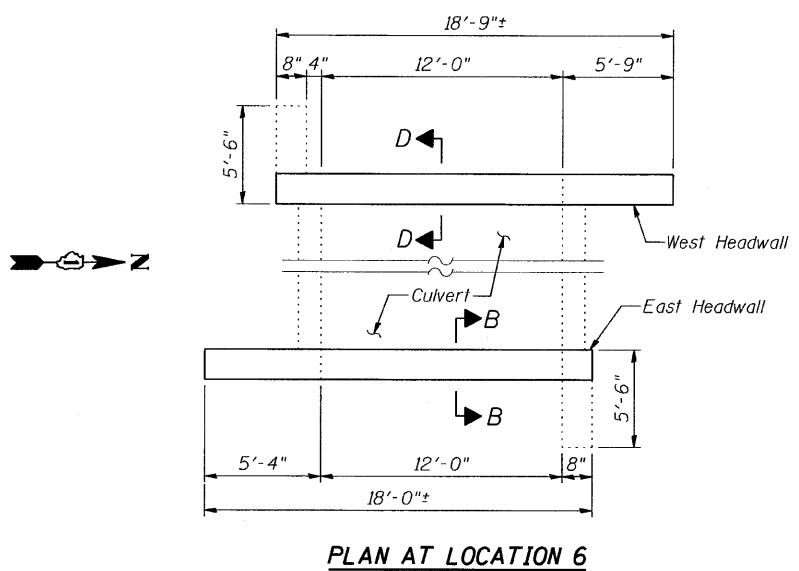

PLAN AT LOCATION 6

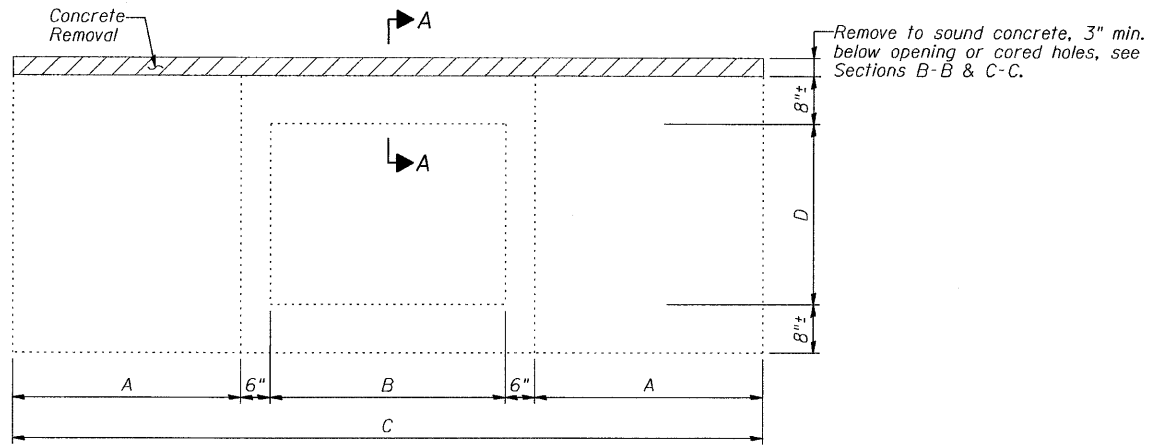

CONCRETE REMOVAL ELEVATION AT LOCATIONS 5 & 7

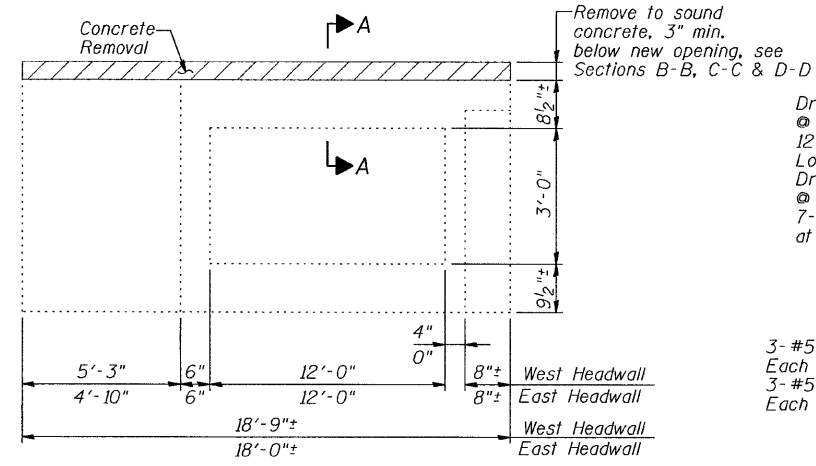

CONCRETE REMOVAL ELEVATION AT LOCATION 6
(FRONT VIEW)

Drill and grout 14-#6 v₁(E) bars @ 6" cts. at Location 5 & 12-#6 v₁(E) bars @ 6" cts. at Location 7, Back Face.
Drill and grout 8-#4 v₂(E) bars @ 12" cts. @ Location 5 & 7-#4 v₂(E) bars @ 12" cts. at Location 7, Front Face.

3-#5 h₁(E) @ 6"± cts. Each Face, Location 5 and 3-#5 h₂(E) @ 6" cts. Each Face, Location 7

Drill and grout 14-#6 v₁(E) bars @ 6" cts. at Location 5 & 12-#6 v₁(E) bars @ 6" cts. at Location 7, Back Face.
Drill and grout 8-#4 v₂(E) bars @ 12" cts. @ Location 5 & 7-#4 v₂(E) bars @ 12" cts. at Location 7, Front Face.

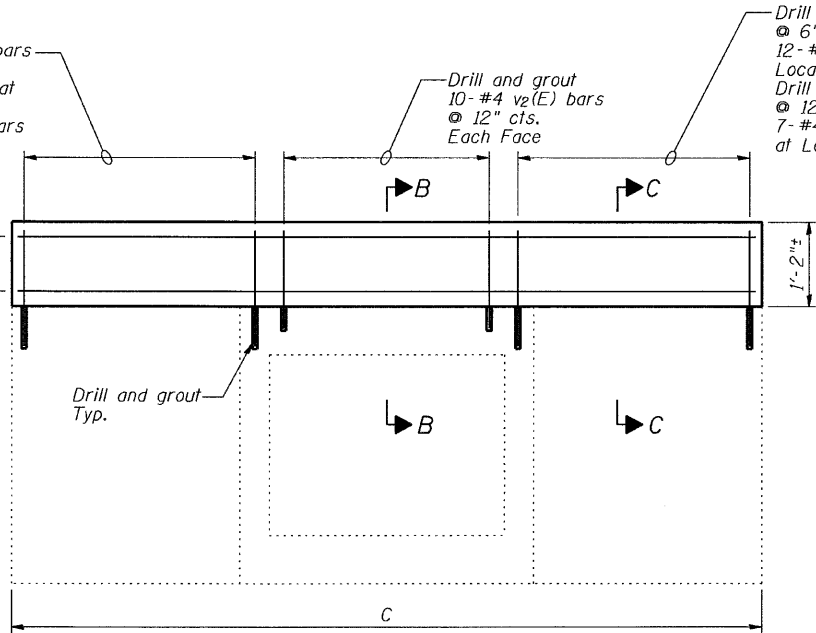

CONCRETE HEADWALL ELEVATION AT LOCATIONS 5 & 7
(FRONT VIEW)

NOTE

1. See next sheet for Sections A-A thru D-D and for reinforcement bar Bill of Material.

Drill and grout 10-#6 v₁(E) bars @ 6" cts. Back Face.
Drill and grout 6-#4 v₂(E) bars @ 12" cts. Front Face.

Drill and grout 13-#4 v₂(E) bars @ 12" cts. Each Face at East Headwall.
Drill and grout 13-#4 v₂(E) bars @ 12" cts. Back Face and drill and grout 13-#4 v₃(E) bars @ 12" cts. Front Face at West Headwall.

3x2-#5 h₃(E) bars @ 6"± cts. Each Face at East Headwall and Back Face at West Headwall.
5x2-#5 h₃(E) bars @ 6"± cts. Front Face at West Headwall

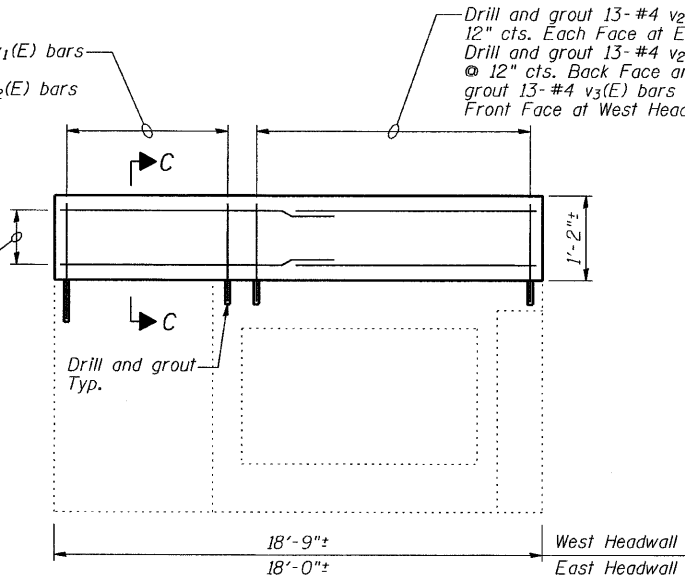

CONCRETE HEADWALL ELEVATION AT LOCATION 6
(FRONT VIEW)

East Headwall Shown, West Headwall Similar.

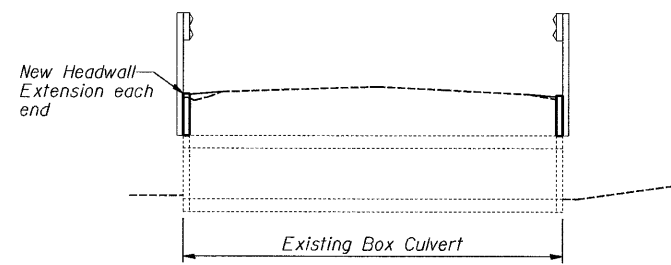

TYPICAL CROSS SECTION

DIMENSIONS

Location	Dimension A	Dimension B	Dimension C	Dimension D
5	7'-9"	10'-0"	26'-6"	5'-0"
7	6'-5"	9'-0"	22'-10"	4'-0"

CULVERT HEADWALL EXTENSION

F.A.P. RTE.	SECTION	COUNTY	TOTAL SHEETS	SHEET NO.
*	2010-004-GRR	McHENRY	16	12
* VARIOUS		CONTRACT NO. 60K22		
ILLINOIS FED. AID PROJECT				

n:\jeb2009\20093023-41\CAD\Site\pgr\00_01_60K22-sh1-Headwall01.dgn
 10/25/2010

GRAEF	10-25-2010
DESIGNED	J.Z.
CHECKED	J.A.Z.
DRAWN	E.U.B.
CHECKED	J.A.Z.

STATE OF ILLINOIS
DEPARTMENT OF TRANSPORTATION

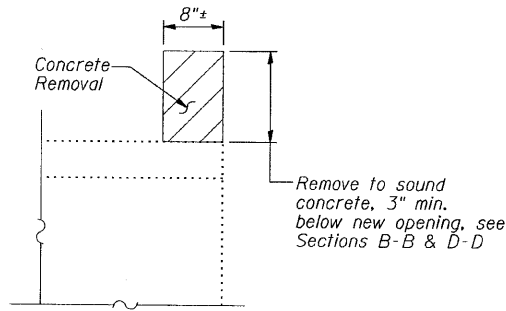

SECTION A-A

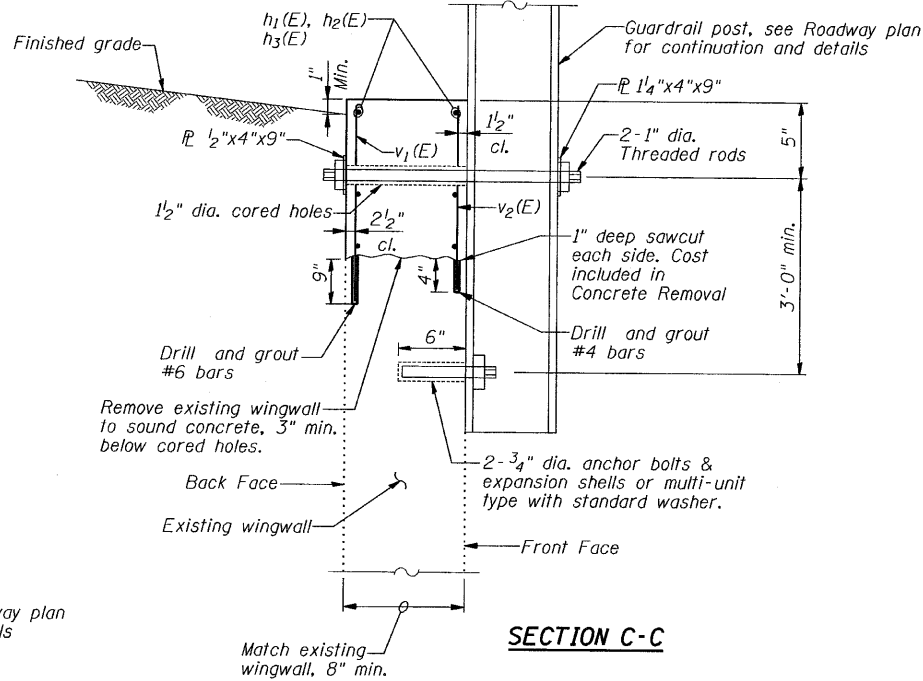

SECTION C-C

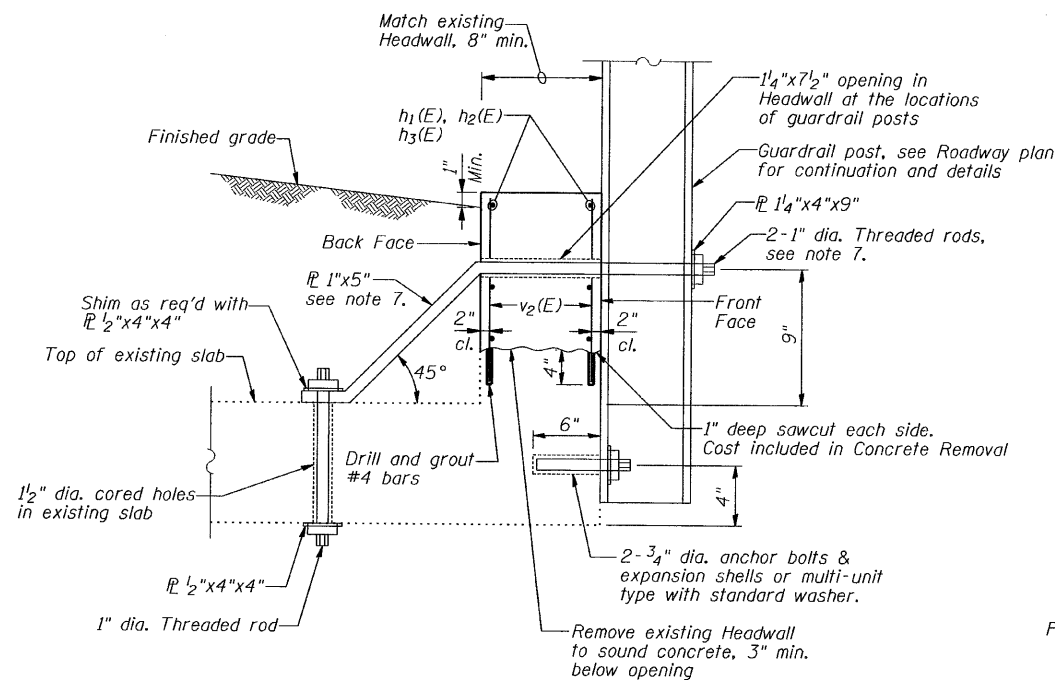

SECTION B-B

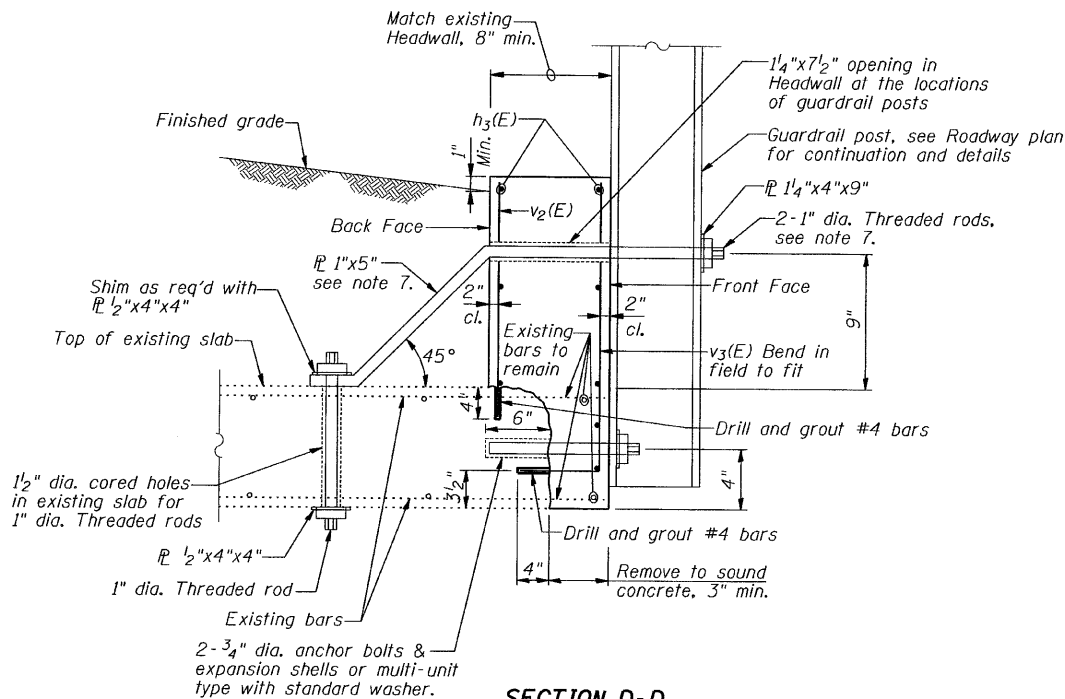

SECTION D-D

BILL OF MATERIAL

Bar	No.	Size	Length	Shape
$h_1(E)$	6	#5	26'-2"	—
$h_2(E)$	6	#5	22'-6"	—
$h_3(E)$	28	#5	9'-11"	—
$v_1(E)$	124	#6	2'-2"	—
$v_2(E)$	191	#4	1'-4"	—
$v_3(E)$	13	#4	2'-3"	—
Concrete Removal		Cu. Yd.	1.0	
Concrete Superstructure		Cu. Yd.	4.0	
Reinforcement Bars, Epoxy Coated		Pound	1,190	

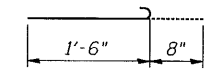

BAR $v_1(E)$

NOTES

- The Headwall shall be constructed entirely of CLASS SI CONCRETE and in accordance with the applicable portions of Section 503 of the Standard Specifications. Reinforcement Bars shall conform to Section 508.
- Reinforcement bars shall conform to the requirements of ASTM A 706 Gr. 60. See Special Provisions.
- Reinforcement bars designated (E) shall be epoxy coated.
- Plan dimensions and details relative to existing plans are subject to nominal construction variations. The Contractor shall field verify existing dimensions and details affecting new construction and make necessary approved adjustments prior to construction or ordering of materials. Such variations shall not be cause for additional compensation for a change in scope of the work, however, the Contractor will be paid for the quantity actually furnished at the unit price bid for the work.
- Drilling and grouting bars shall be in accordance with Section 584 of the Standard Specifications.
- Contractor is to locate the existing reinforcement bars in culverts prior to drilling to avoid damaging existing reinforcement bars.
- For the details of guardrail elements not shown, see Roadway Standard "Guardrail Mounted on Existing Culverts" (Standard 630101-09).
- The cost of the hardware and work for the installation of guardrail posts is included in the Pay Item "Steel Plate Beam Guardrail Attached to Structures".
- Existing reinforcement bars to remain shall be blast cleaned to grey metal and incorporated into new concrete. Cost is included in "Concrete Removal".

GRAEF	10-25-2010
DESIGNED	J.Z.
CHECKED	J.A.Z.
DRAWN	E.U.B.
CHECKED	J.A.Z.

CULVERT HEADWALL EXTENSION

F.A.P. RTE.	SECTION	COUNTY	TOTAL SHEETS	SHEET NO.
*	2010-004-GRR	McHENRY	16	13
* VARIOUS		CONTRACT NO. 60K22		
ILLINOIS FED. AID PROJECT				

STATE OF ILLINOIS
DEPARTMENT OF TRANSPORTATION

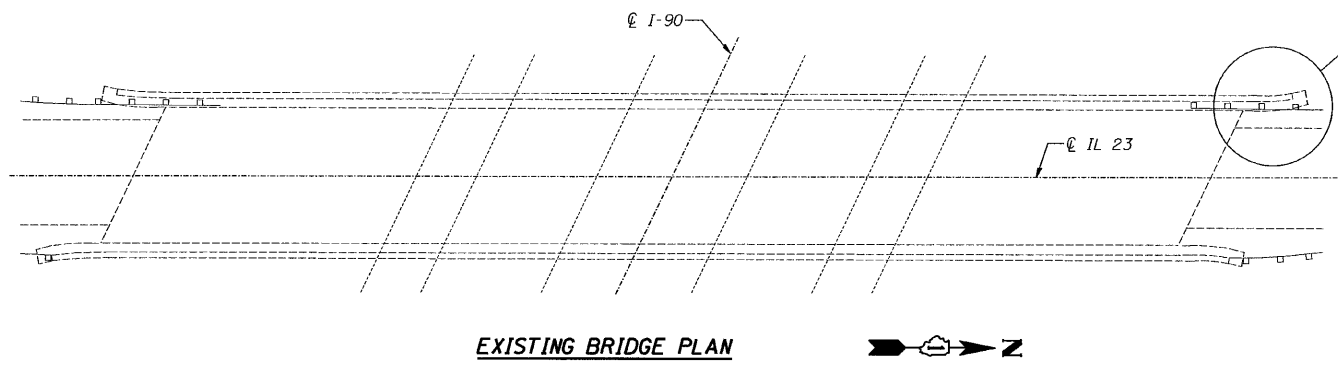

Remove and replace end parapet. Typ. at each corner of the bridge. See details on this Sheet.

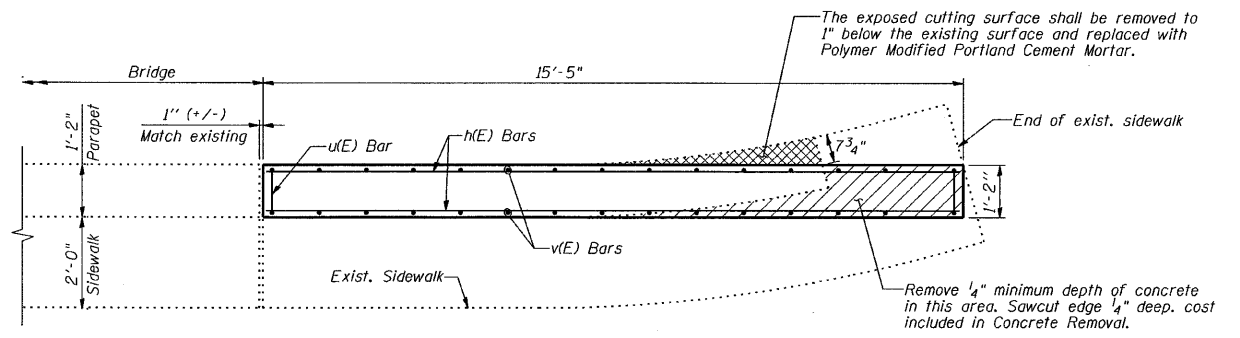

NEW END PARAPET PLAN

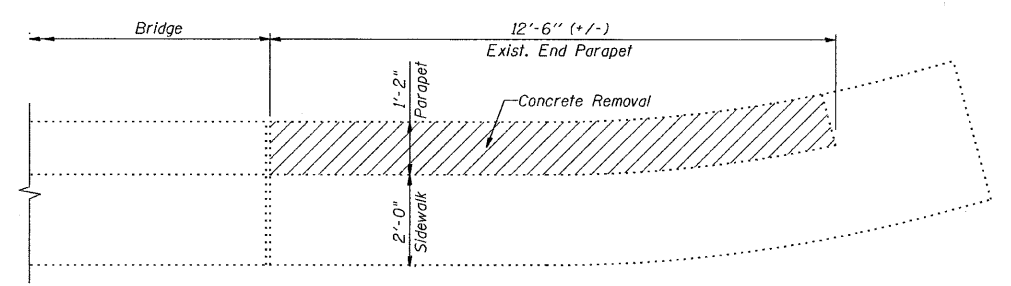

CONCRETE REMOVAL PLAN

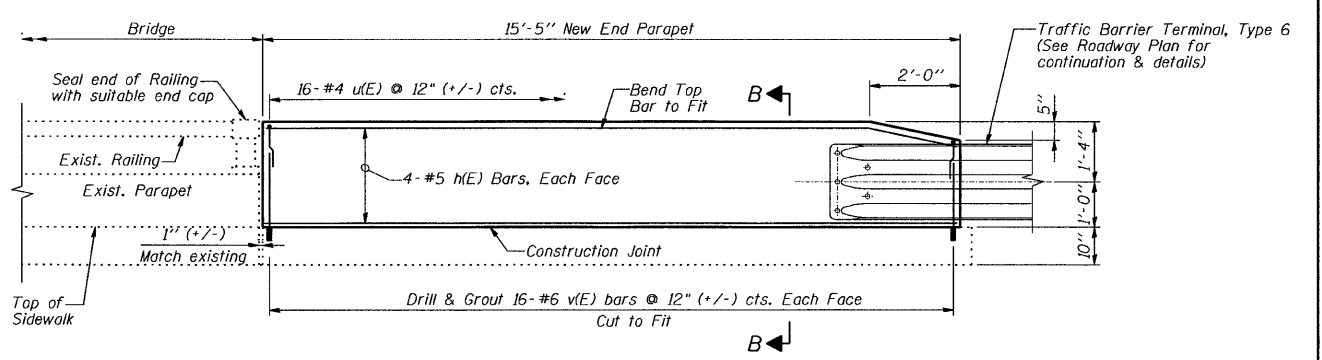

NEW END PARAPET ELEVATION (FRONT VIEW)

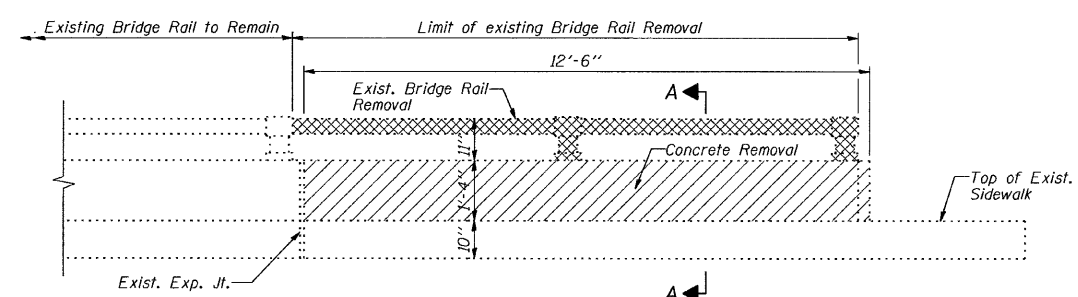

REMOVAL ELEVATION

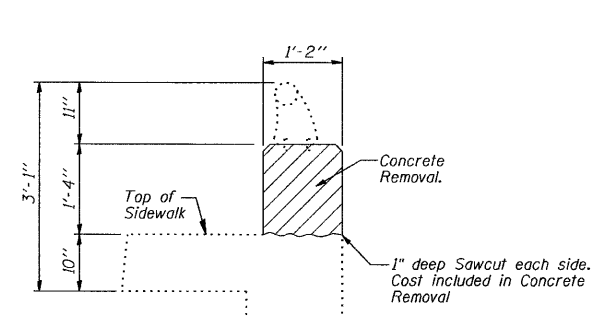

SECTION A-A

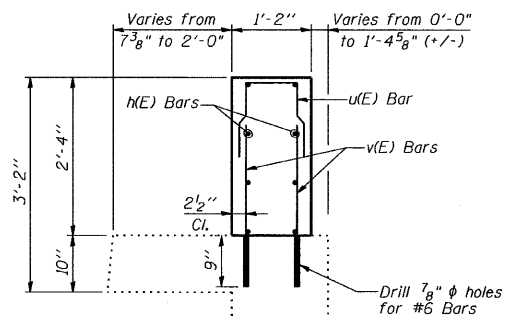

SECTION B-B

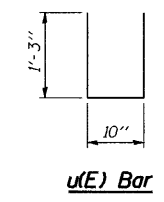

u(E) Bar

NOTES

1. Reinforcement bars shall conform to the requirements of ASTM A 706 Gr. 60. See Special Provisions.
2. Reinforcement bars designated (E) shall be epoxy coated.
3. Plan dimensions and details relative to existing plans are subject to nominal construction variations. The Contractor shall field verify existing dimensions and details affecting new construction and make necessary approved adjustments prior to construction or ordering of materials. Such variations shall not be cause for additional compensation for a change in scope of the work, however, the Contractor will be paid for the quantity actually furnished at the unit price bid for the work.
4. Drilling and grouting bars shall be in accordance with Section 584 of the Standard Specifications.

BILL OF MATERIAL

Bar	No.	Size	Length	Shape
h (E)	32	#5	15'-1"	—
v (E)	128	#6	2'-10"	—
u (E)	64	#4	3'-4"	□
Concrete Removal		Cu. Yd.	3.0	
Bridge Rail Removal		LF	56.0	
Concrete Superstructure		Cu. Yd.	6.2	
Reinforcement Bars, Epoxy Coated		Pound	4,760	
Polymer Modified Portland Cement Mortar		Sq. Ft.	9.0	

The quantities above include 4 new end parapets.

GRAEF	10-25-2010
DESIGNED	J.Z.
CHECKED	J.A.Z.
DRAWN	E.U.B.
CHECKED	J.A.Z.

STRUCTURE 056-0011 IL 23 OVER I-90				
F.A.P. RTE.	SECTION	COUNTY	TOTAL SHEETS	SHEET NO.
*	2010-004-GRR	McHENRY	16	14
* VARIOUS		CONTRACT NO. 60K22		
ILLINOIS FED. AID PROJECT				

h:\jbs2009\20093023-41\cad\site\dgn\00\160k22-snt-wingwall.dgn 10/25/2010

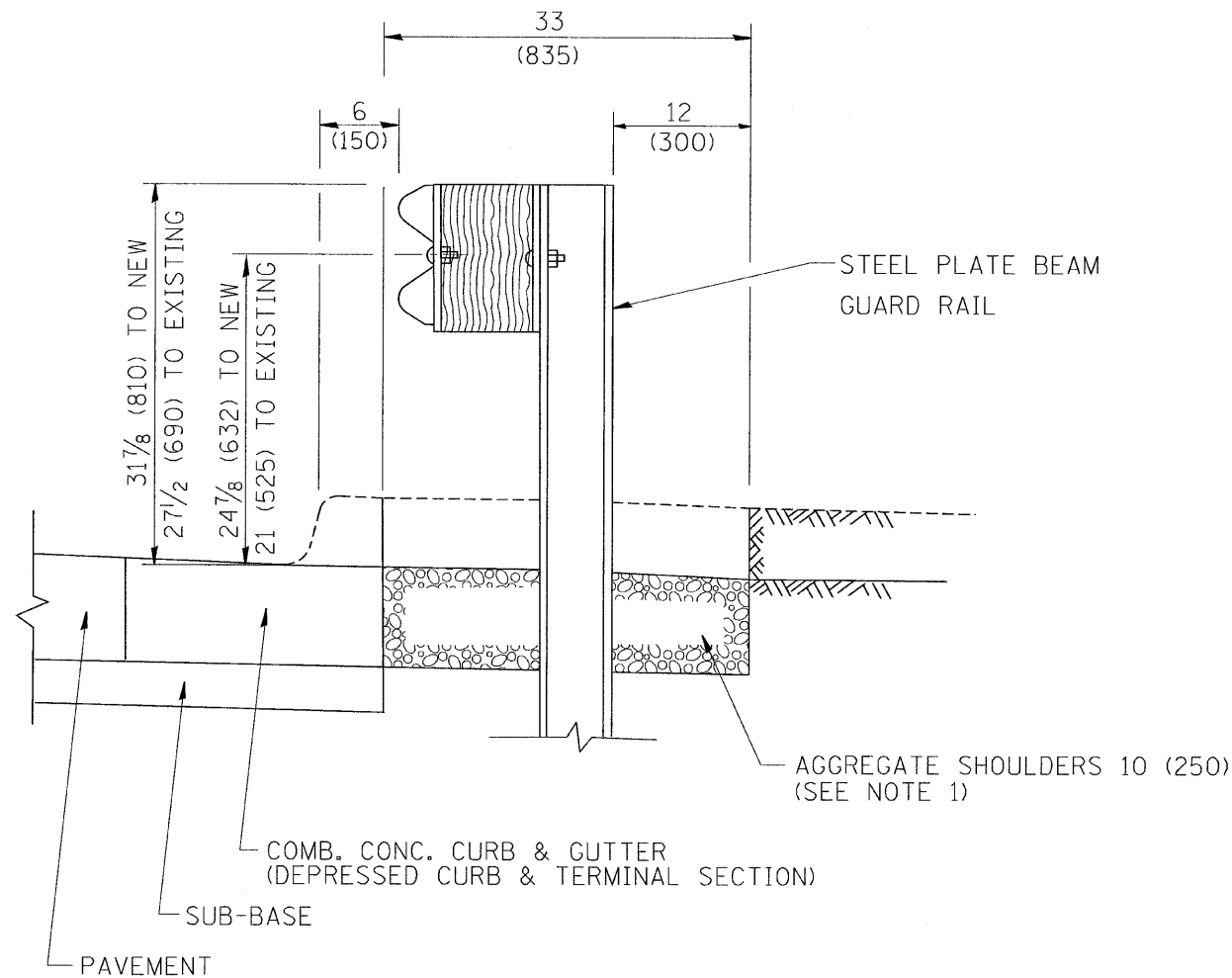

SECTION A-A

- NOTES:
1. THE AGGREGATE SHOULDER, 10" OR HMA SHOULDER, 6" (IF REQUIRED) SHALL EXTEND UNDER THE TRAFFIC BARRIER TERMINAL.
 2. "EXISTING" GUARDRAIL REFERS TO CONNECTING TERMINAL SECTION TO GUARD RAILING PRIOR TO THE MIDWEST GUARDRAIL SYSTEM.
 3. THE CONTRACTOR SHALL VERIFY THE TYPE/HEIGHT OF GUARDRAIL IN-PLACE BEFORE ORDERING THE NEW TERMINAL. COST INCLUDED WITH THE COST OF THE TERMINAL. THE TERMINAL SECTION HEIGHT TO BE PLACED MUST MATCH THE HEIGHT OF THE IN-PLACE GUARDRAIL.

**DETAILS FOR STEEL PLATE BEAM
GUARD RAIL ADJACENT TO CURB AND GUTTER**
[FOR ROADWAY SPEED 35 MPH (60 kmh) TO 45 MPH (70 kmh)]

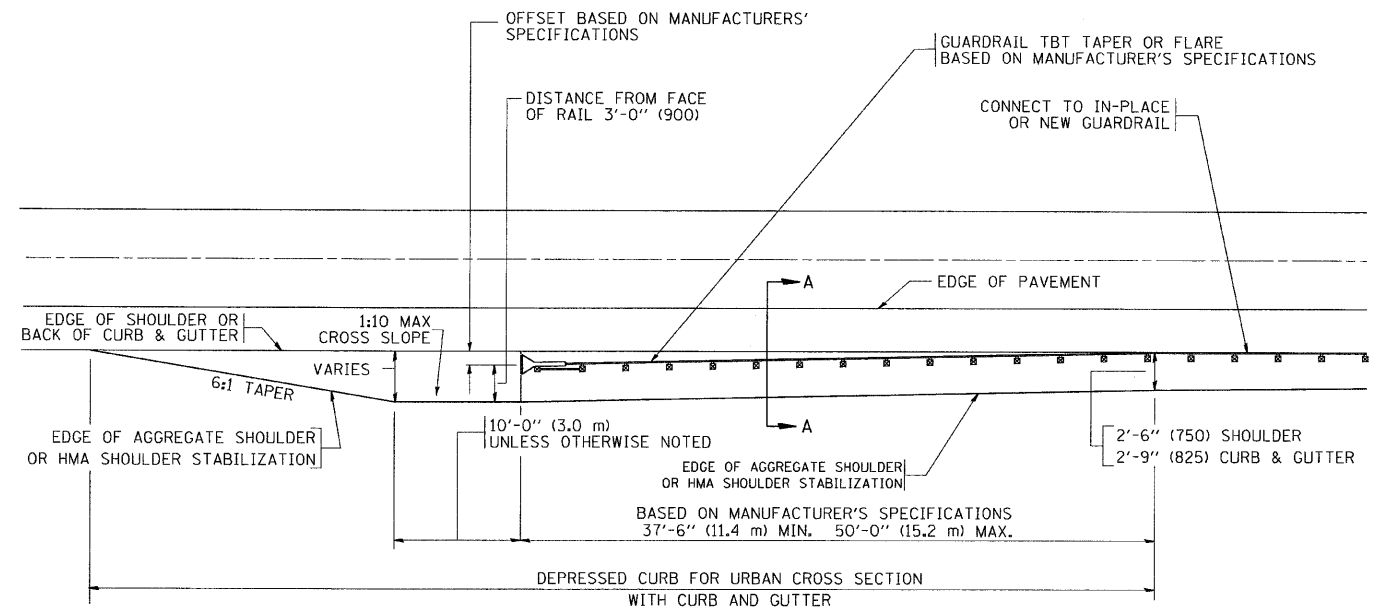

**DEPRESSED CURB AND GUTTER AND
SHOULDER TREATMENT AT TBT TY. 1 SPL.**

BASIS OF PAYMENT: HMA SHOULDERS 6 (150) (IF REQUIRED) WILL BE PAID FOR AT THE CONTRACT UNIT PRICE PER SQUARE YARD (SQUARE METER) FOR "HOT-MIX ASPHALT SHOULDERS 6" (150 mm)".

STEEL PLATE BEAM GUARD RAIL AND TRAFFIC BARRIER TERMINAL, OF THE TYPE SPECIFIED WILL BE PAID FOR SEPARATELY.

TBT = TRAFFIC BARRIER TERMINAL
ALL DIMENSIONS ARE IN INCHES (MILLIMETERS) UNLESS OTHERWISE SHOWN.
* VARIOUS ROUTES

FILE NAME =	USER NAME = drivakosgn	DESIGNED - M. DE YONG	REVISED - E. GOMEZ 08-28-00
c:\pw_work\PWIDOT\DRIVAKOSGN\0108315\034.dgn		DRAWN -	REVISED - R. BORO 01-01-07
	PLOT SCALE = 49.9999' / IN.	CHECKED -	REVISED - R. BORO 12-08-2008
	PLOT DATE = 9/21/2009	DATE - 09-22-90	REVISED - R. BORO 09-14-2009

STATE OF ILLINOIS
DEPARTMENT OF TRANSPORTATION

DETAILS FOR DEPRESSED CURB & GUTTER AND SHOULDER TREATMENT AT TBT TY 1 SPL.			
SCALE: NONE	SHEET NO. 1 OF 1 SHEETS	STA.	TO STA.

F.A. RTE.	SECTION	COUNTY	TOTAL SHEETS	SHEET NO.
*	2010-004 GRR	McHenry	16	15
BD600-10 (BD 34)			CONTRACT NO. 60K22	
FED. ROAD DIST. NO. 1 ILLINOIS FED. AID PROJECT				

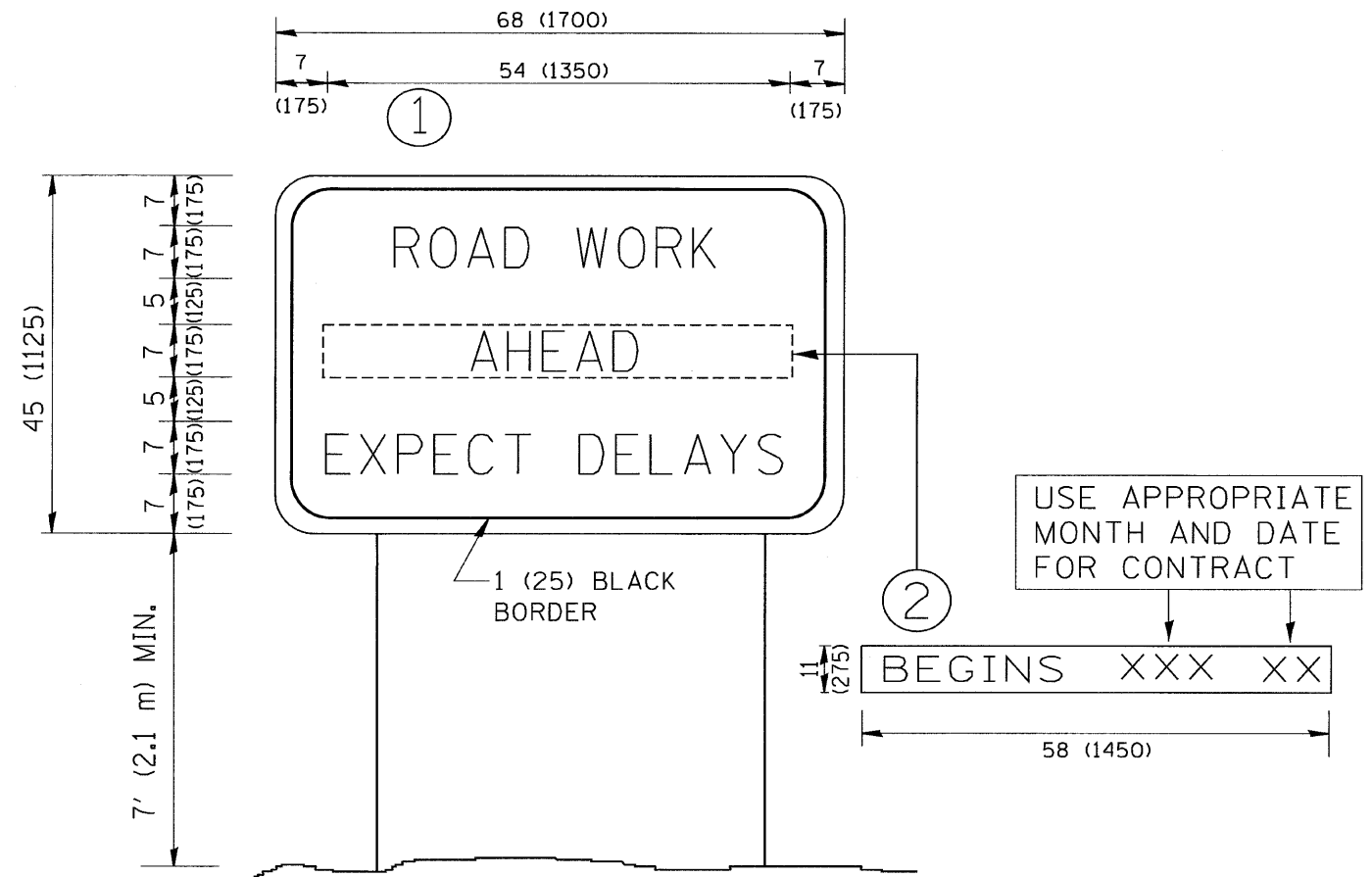

NOTES:

1. USE BLACK LETTERING ON ORANGE BACKGROUND.
2. ERECT SIGNS IN ADVANCE OF THE LOCATION FOR THE "ROAD CONSTRUCTION AHEAD" SIGN AT LOCATIONS AS DIRECTED BY THE ENGINEER.
3. ERECT SIGN ① WITH INSTALLED PANEL ② ONE WEEK PRIOR TO THE START OF CONSTRUCTION.
4. REMOVE PANEL ② SOON AFTER THE START OF CONSTRUCTION.
5. SEE SPECIAL PROVISION FOR "TEMPORARY INFORMATION SIGNING" FOR ADDITIONAL INFORMATION.
6. ONE SIGN ASSEMBLY EQUALS 25.70 SQ. FT. (2.3 SQ. M.)
7. SHALL BE PAID FOR AS TEMPORARY INFORMATION SIGNING.

ALL DIMENSIONS ARE IN INCHES (MILLIMETERS) UNLESS OTHERWISE SHOWN.

* VARIOUS ROUTES

FILE NAME = M:\diststd\22x34\to22.dgn	USER NAME = geglentobt	DESIGNED -	REVISED - R. MIRS 09-15-97	STATE OF ILLINOIS DEPARTMENT OF TRANSPORTATION	ARTERIAL ROAD INFORMATION SIGN			F.A. RTE. *	SECTION	COUNTY	TOTAL SHEETS	SHEET NO.	
	PLOT SCALE = 50.000 1 / IN.	DRAWN -	REVISED - R. MIRS 12-11-97		SCALE: NONE	SHEET NO. 1 OF 1 SHEETS	STA.	TO STA.	2010-004 GRR	McHenry	16	16	
	PLOT DATE = 1/4/2008	CHECKED -	REVISED - T. RAMMACHER 02-02-99						TC-22				
		DATE -	REVISED - C. JUCIUS 01-31-07						CONTRACT NO. 60K22				
FED. ROAD DIST. NO. 1 ILLINOIS FED. AID PROJECT													