

**TOP SLAB PLAN**

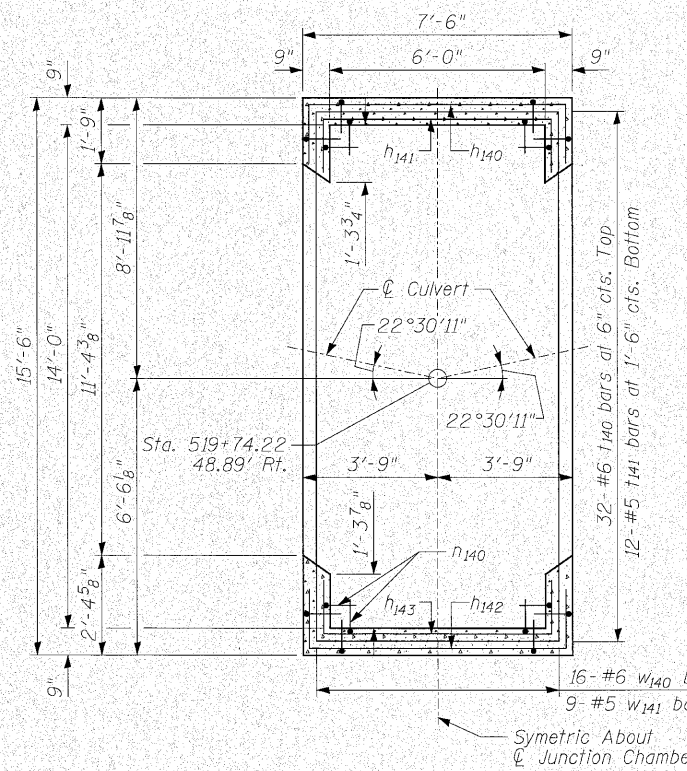

**BOTTOM SLAB PLAN**

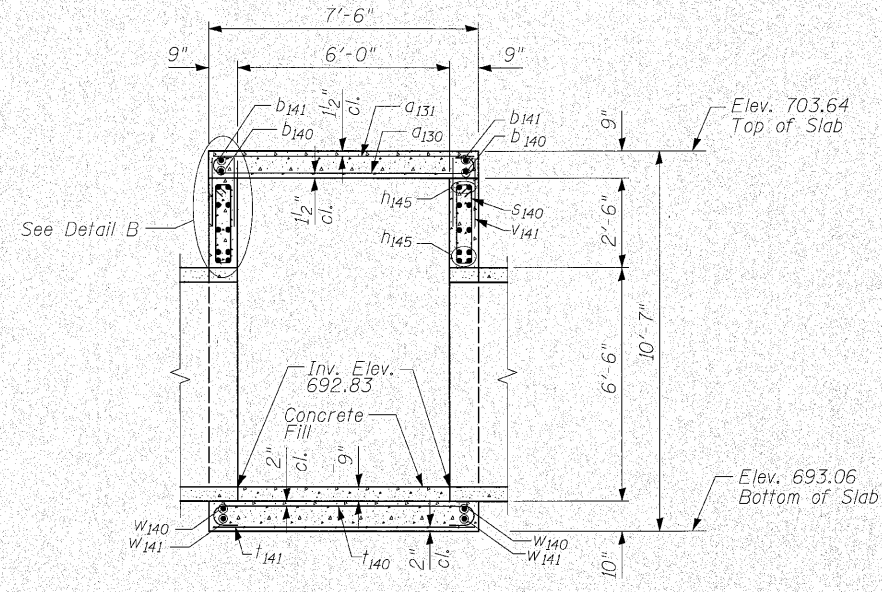

**SECTION A-A**

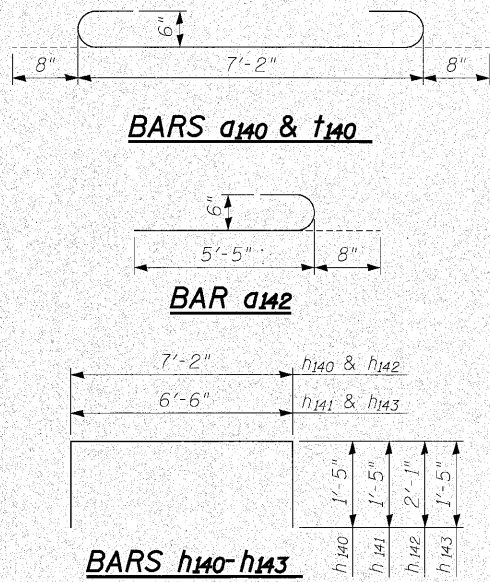

**BILL OF MATERIAL**

Bar	No.	Size	Length	Shape
a140	29	#6	8'-6"	C
a141	11	#5	7'-2"	—
a142	4	#6	6'-1"	C
a143	1	#5	5'-5"	—
a144	2	#6	6'-10"	—
b140	8	#6	15'-2"	—
b141	6	#4	15'-2"	—
b142	3	#6	13'-5"	—
b143	2	#4	13'-5"	—
h140	10	#5	10'-0"	—
h141	10	#5	9'-4"	—
h142	10	#5	11'-4"	—
h143	10	#5	9'-4"	—
h144	16	#5	2'-0"	—
h145	20	#8	15'-2"	—
h146	64	#5	3'-10"	L
s140	48	#4	6'-3"	C
t140	32	#6	8'-6"	C
t141	12	#5	7'-2"	—
v140	64	#5	9'-6"	—
v141	96	#4	1'-10"	—
w140	16	#6	15'-2"	—
w141	9	#5	15'-2"	—
Concrete Structures			Cu. Yd.	15.7
Reinforcement Bars			Pound	4,310

Note:  
Quantity of Concrete Structures and Reinforcement Bars is shown for information only.

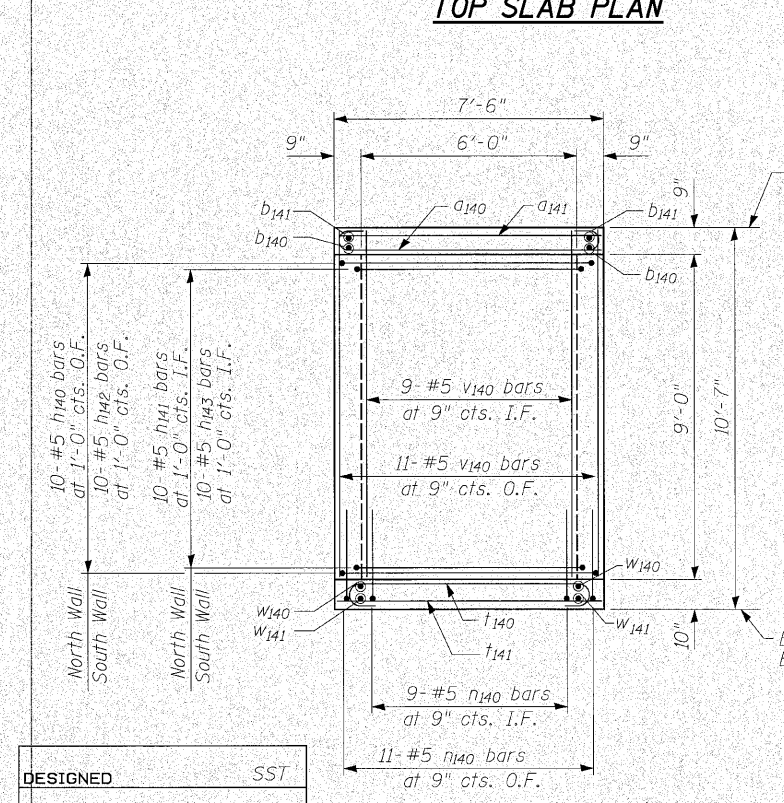

**NORTH WALL ELEVATION  
SOUTH WALL ELEVATION**

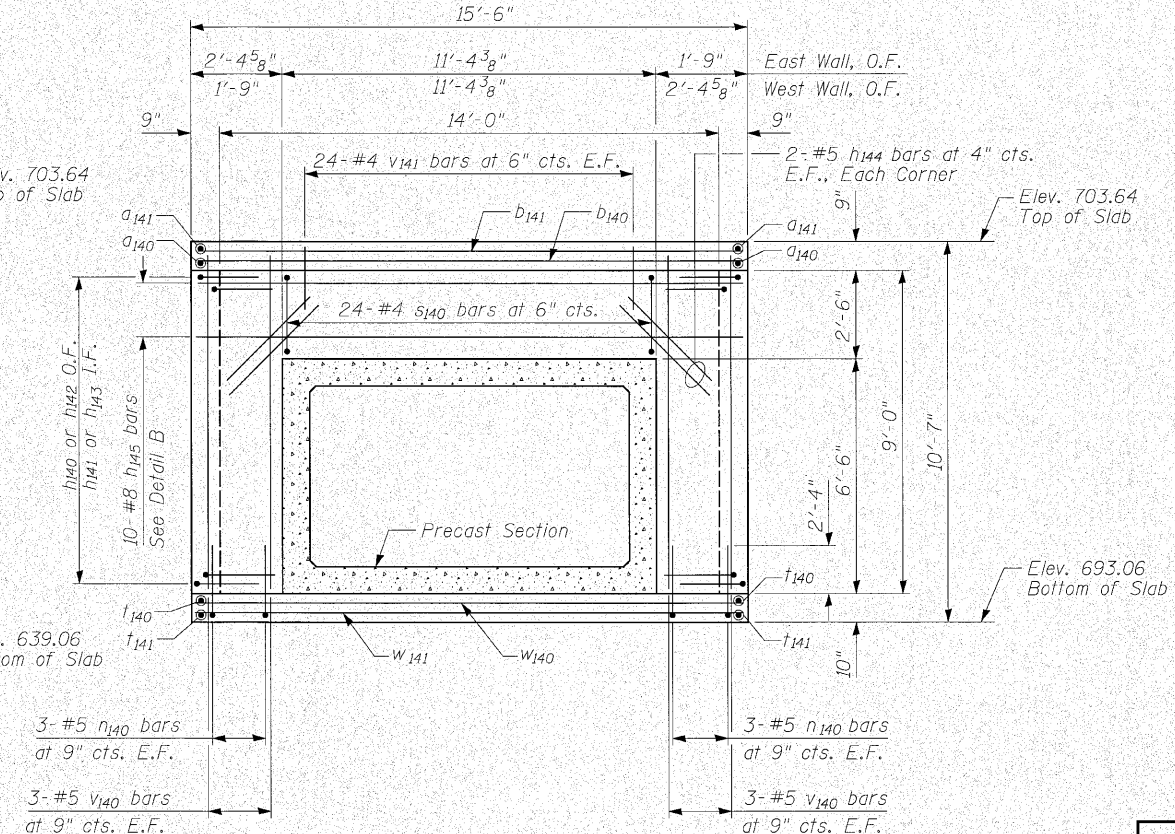

**EAST WALL ELEVATION  
WEST WALL ELEVATION**

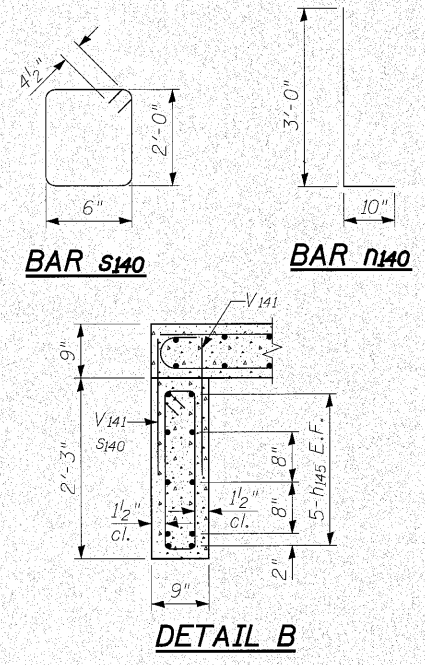

**DETAIL B**

DESIGNED	SST
CHECKED	SPK
DRAWN	JHP
CHECKED	SST

**INFRASTRUCTURE ENGINEERING** | INCORPORATED  
33 West Monroe | Suite 1540 | Chicago, IL 60603  
P 312.425.9560 | F 312.425.9564 | www.infrastructure-eng.com

**JUNCTION CHAMBER NO. 7**  
**U.S. ROUTE 30 AND HILLSIDE ROAD OVER**  
**TRIBUTARY TO HICKORY CREEK**  
**F.A.P. ROUTE 353 SEC. (12&13)WRS-4**  
**WILL COUNTY**  
**STATION 520+20.00**  
**STRUCTURE NO. 099-C027**

P:\P\_03\1505\0-Drawings\Final Design\20-00-Drawings\Sheets\c1\522-struct\09J07.dwg 3/5/2010 3:58:30 PM