

STATE OF ILLINOIS
DEPARTMENT OF TRANSPORTATION

ROUTE NO.	SECTION	COUNTY	TOTAL SHEETS	SHEET NO.
353	(12&13)WRS-4	Willi	608	483
ILLINOIS		FED. AID PROJECT		

Contract No. 6247B

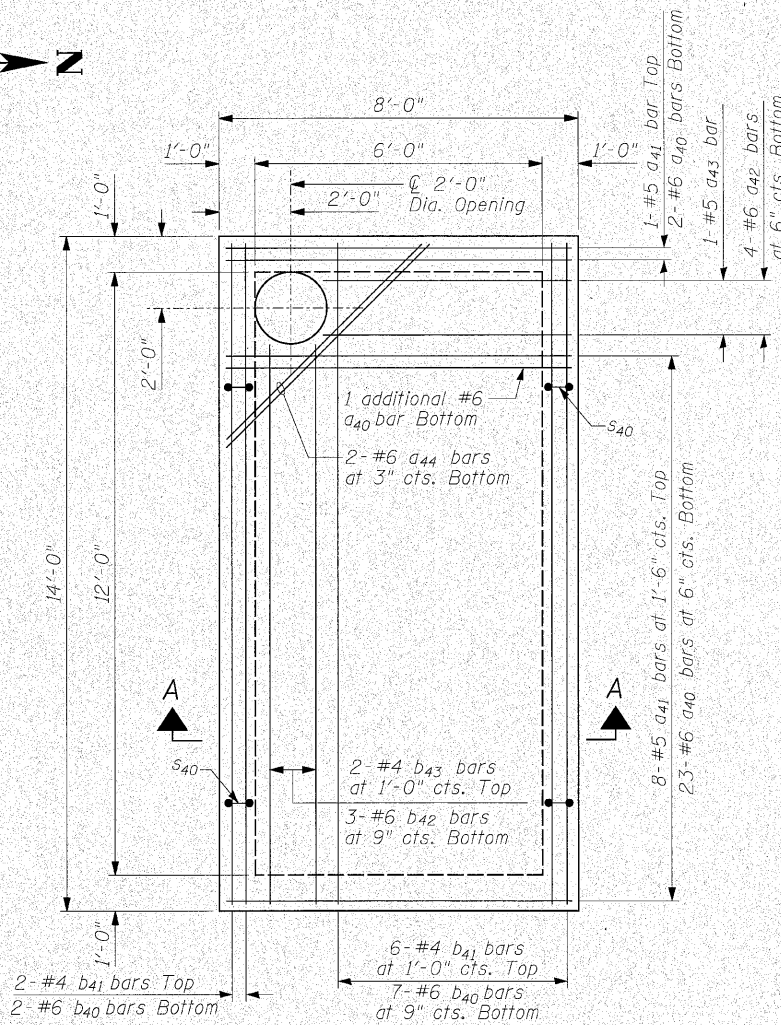

TOP SLAB PLAN

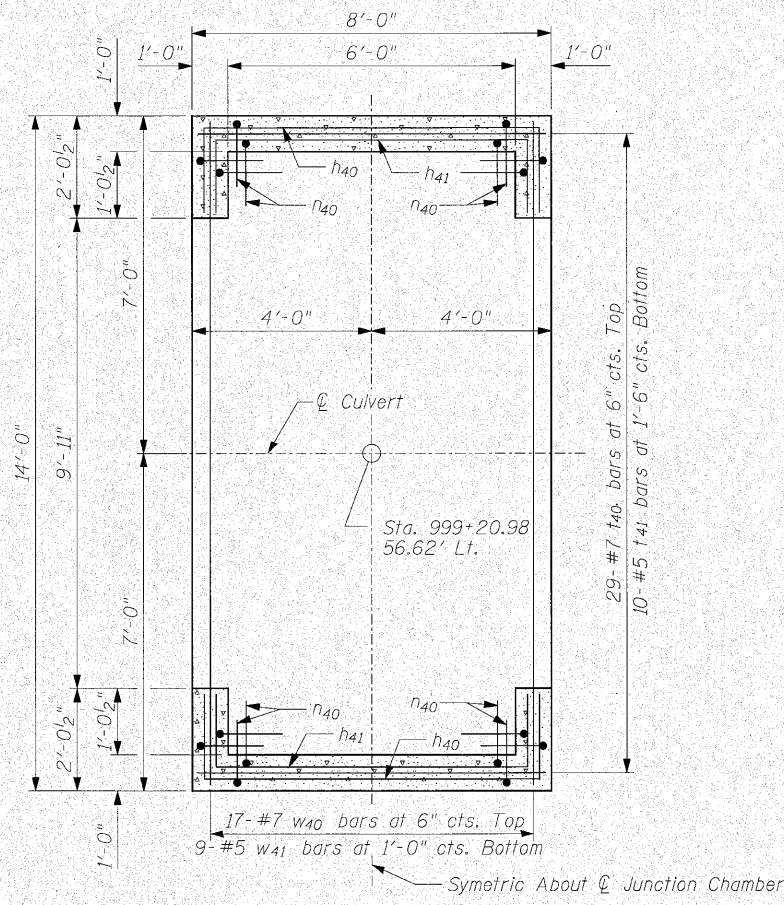

BOTTOM SLAB PLAN

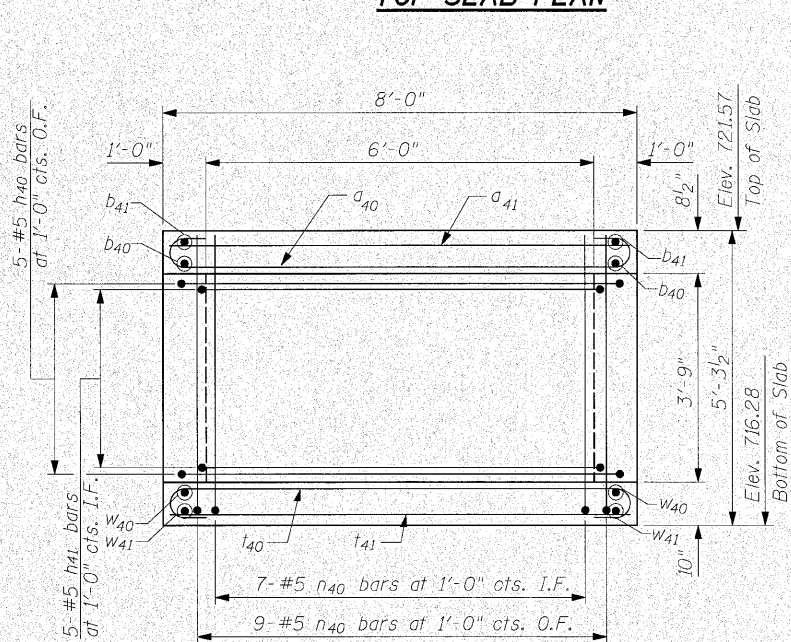

**EAST WALL ELEVATION
WEST WALL ELEVATION**

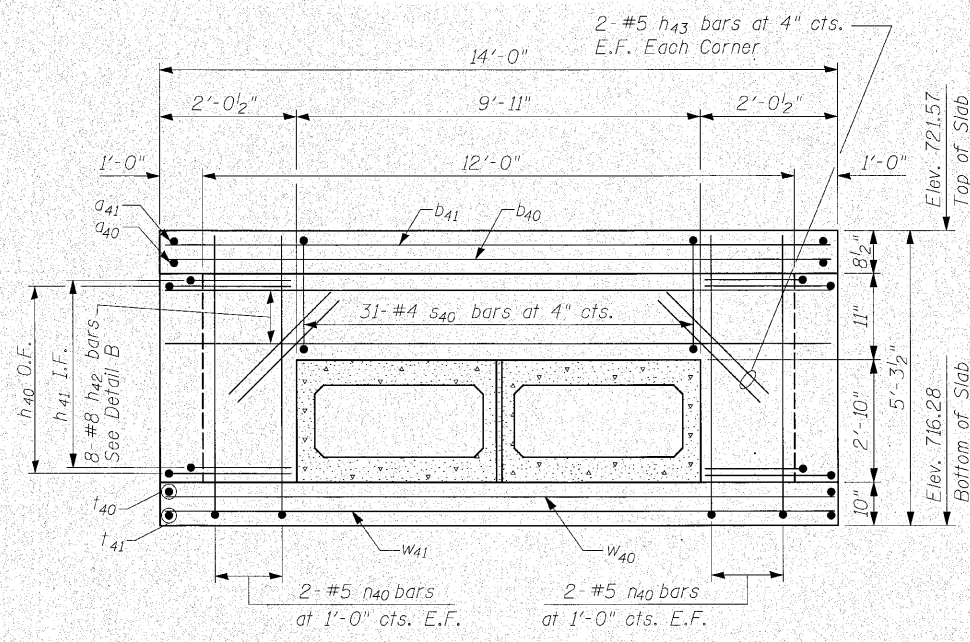

**NORTH WALL ELEVATION
SOUTH WALL ELEVATION**

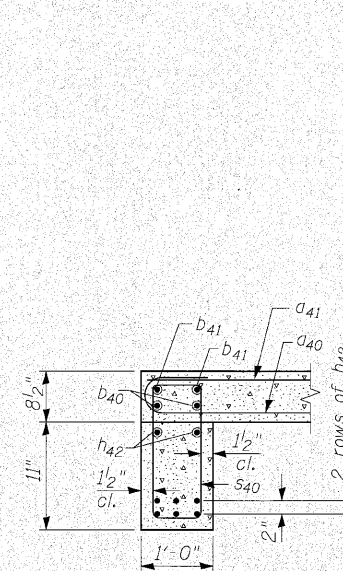

DETAIL B

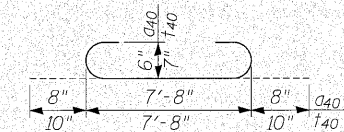

BARS a40 & t40

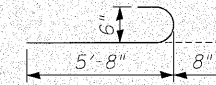

BAR a42

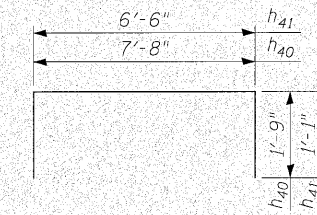

BARS h40 & h41

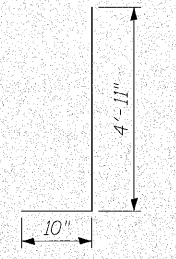

BAR n40

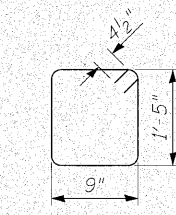

BAR s40

BILL OF MATERIAL

Bar	No.	Size	Length	Shape
a40	26	#6	9'-0"	U
a41	9	#5	7'-8"	U
a42	4	#6	6'-4"	U
a43	1	#5	5'-8"	U
a44	2	#6	8'-0"	U
b40	9	#6	13'-8"	—
b41	8	#4	13'-8"	—
b42	3	#6	11'-8"	—
b43	2	#4	11'-8"	—
h40	10	#5	11'-2"	┌
h41	10	#5	8'-8"	┌
h42	16	#8	13'-8"	—
h43	16	#5	2'-0"	—
n40	48	#5	5'-9"	L
s40	62	#4	5'-1"	└
t40	29	#7	9'-4"	U
t41	10	#5	7'-8"	—
w40	17	#7	13'-8"	—
w41	9	#5	13'-8"	—
Concrete Structures			Cu. Yd.	10.9
Reinforcement Bars			Pound	3,380

Note:
Quantity of Concrete Structures and Reinforcement Bars is shown for information only.

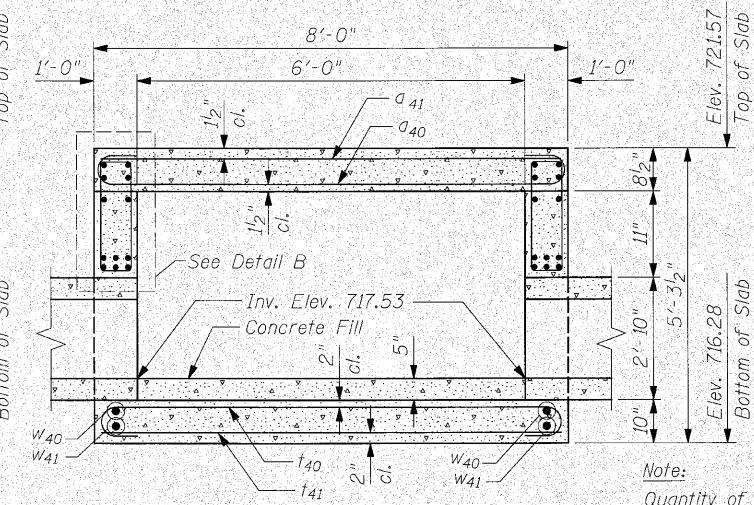

SECTION A-A

DESIGNED	SST
CHECKED	SPK
DRAWN	JHP
CHECKED	SST



**INFRASTRUCTURE
ENGINEERING** | INCORPORATED
33 West Monroe | Suite 1540 | Chicago, IL 60603
P 312.425.9560 | F 312.425.9564 | www.infrastructure-eng.com

**JUNCTION CHAMBER NO. 10
U.S. ROUTE 30 OVER
DRAINAGE DITCH
F.A.P. ROUTE 353 SEC. (12&13)WRS-4
WILL COUNTY
STATION 579+38.78
STRUCTURE NO. 099-C028**