

EXISTING TYPICAL SECTION
CHERRY AVE.
STATION 21+03.5 TO STATION 24+40.0

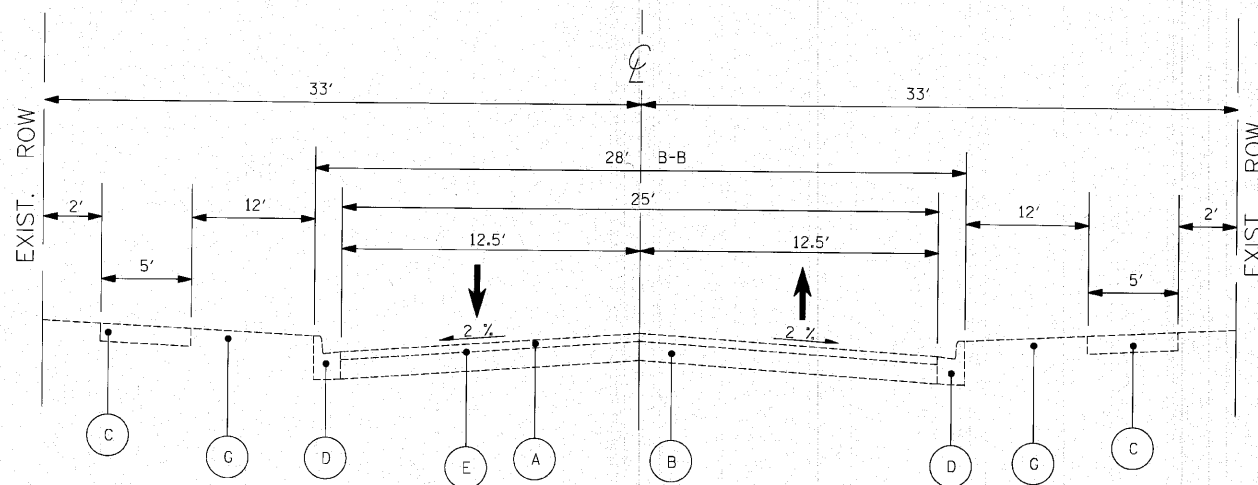

EXISTING TYPICAL SECTION
CHERRY AVE.
STATION 24+40.0 TO STATION 36+35.0

EXISTING LEGEND

- (A) HOT-MIX ASPHALT CONCRETE SURFACE COURSE, 3" (AVG.)
- (B) EXISTING AGGREGATE BASE, 8"
- (C) P.C.C. SIDEWALK, 5"
- (D) B-6.12 CONCRETE CURB AND GUTTER
- (E) HOT-MIX ASPHALT SURFACE REMOVAL 3 3/4"
- (F) HOT MIX ASPHALT DRIVEWAY
- (G) TOPSOIL & SOD

FILE NAME =	USER NAME = #USER#	DESIGNED -	REVISED -
P:\F0140490 - BIRCH AND CHERRY RECONSTRUCTION\PLANS\SHEETS\F0140940TSST0101.dgn		DRAWN -	REVISED -
PLOT SCALE = 5.0000' / IN.		CHECKED -	REVISED -
PLOT DATE = 10/25/2010		DATE -	REVISED -

**STATE OF ILLINOIS
DEPARTMENT OF TRANSPORTATION**

BIRCH ST. & CHERRY AVE.
EXISTING TYPICAL SECTIONS-CHERRY AVE.
SCALE: N/A SHEET NO. 1 OF 2 SHEETS STA. 21+03.50 TO STA. 36+35

F.A. RTE.	SECTION	COUNTY	TOTAL SHEETS	SHEET NO.
	10-00076-00-FP	COOK	44	4
CONTRACT NO. 63258				
ILLINOIS FED. AID PROJECT				