

Notes:
 Bars indicated thus 1 x 2 - #5 etc. indicates 1 line of bars with 2 lengths per line.
 I.F. = Inside Face
 O.F. = Outside Face
 E.F. = Each Face

MIN. BAR LAP
 #4 bar = 1'-4"
 #8 bar = 3'-5"

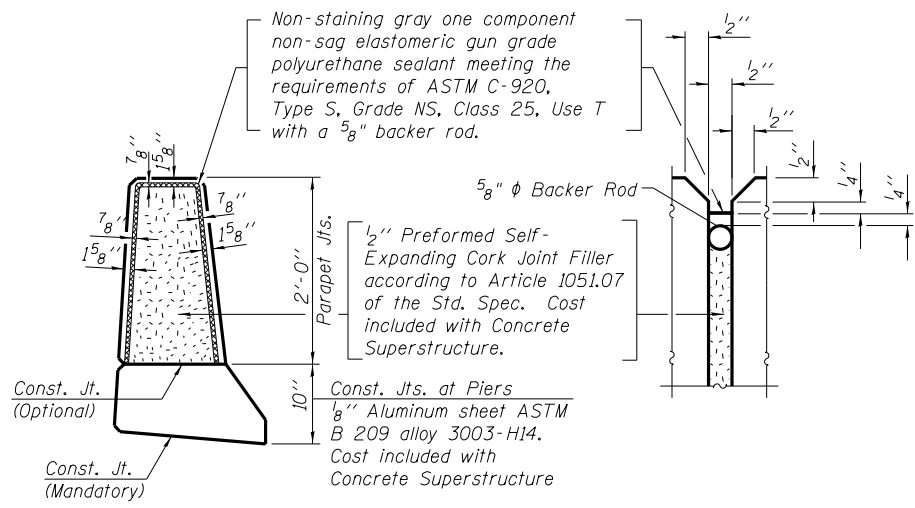

(South Parapet)

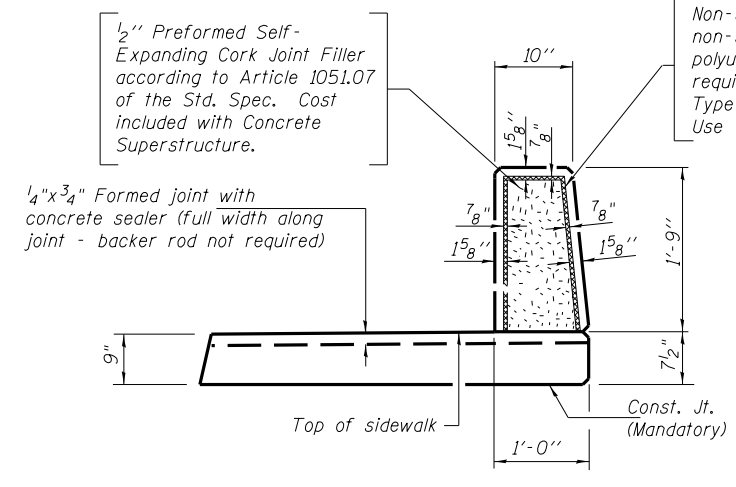

(North Parapet)

PARAPET JOINT DETAILS

| | |
|----------|-----|
| DESIGNED | BAN |
| CHECKED | JOH |
| DRAWN | TD |
| CHECKED | BAN |

SUPERSTRUCTURE DETAILS
 MOUND ROAD (FAU ROUTE 8173)
 OVER ILLINOIS ROUTE 104
 SECTION (69-HB)BR
 MORGAN COUNTY
 STATION 100+00.00
 STRUCTURE NO. 069-0521

HU CHISON ENGINEERING, INC.
 JACKSONVILLE, ILLINOIS
 Date: 12/21/07