

F.A.U. RTE.	SECTION	COUNTY	TOTAL SHEETS	SHEET NO.
8173	(69-HB)BR	MORGAN	63	56
FED. ROAD DIST. NO.	ILLINOIS	FED. AID PROJECT		

CONTRACT NO. 72837

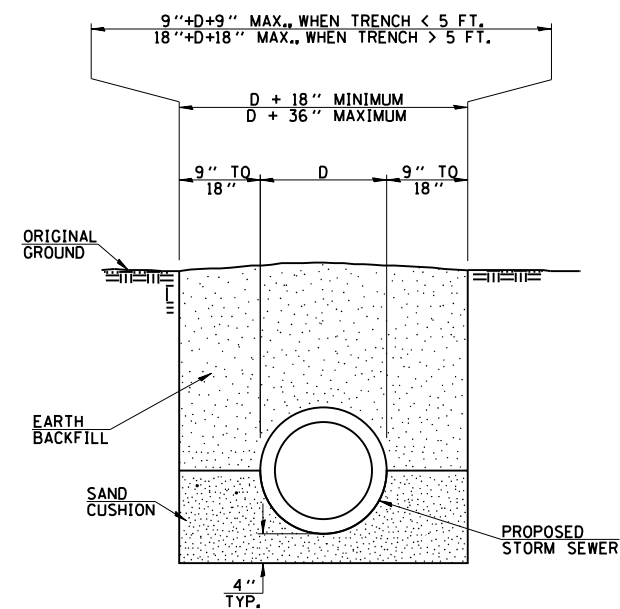

DETAIL OF TRENCH EXCAVATION AND BACKFILL UNDER TURF

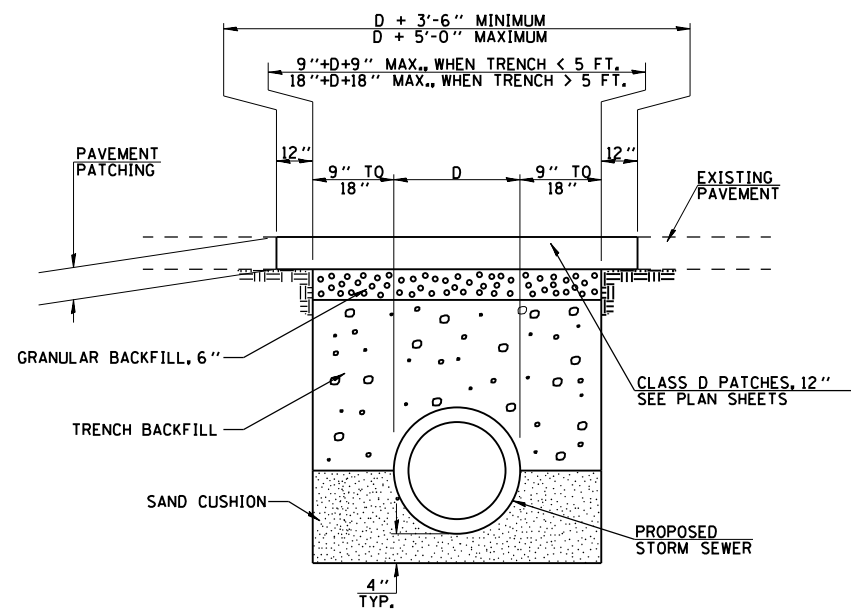

NOTE:
THE TRENCH BACKFILL QUANTITIES SHOWN ON THE PLANS INCLUDE THE VOLUME OF GRANULAR BACKFILL. GRANULAR BACKFILL WILL NOT BE PAID FOR SEPARATELY, BUT WILL BE PAID FOR AT THE CONTRACT UNIT PRICE PER CU. YD. FOR TRENCH BACKFILL.

DETAIL OF TRENCH EXCAVATION, PAVEMENT REMOVAL, PAVEMENT REPLACEMENT AND BACKFILL UNDER EXISTING PAVEMENT

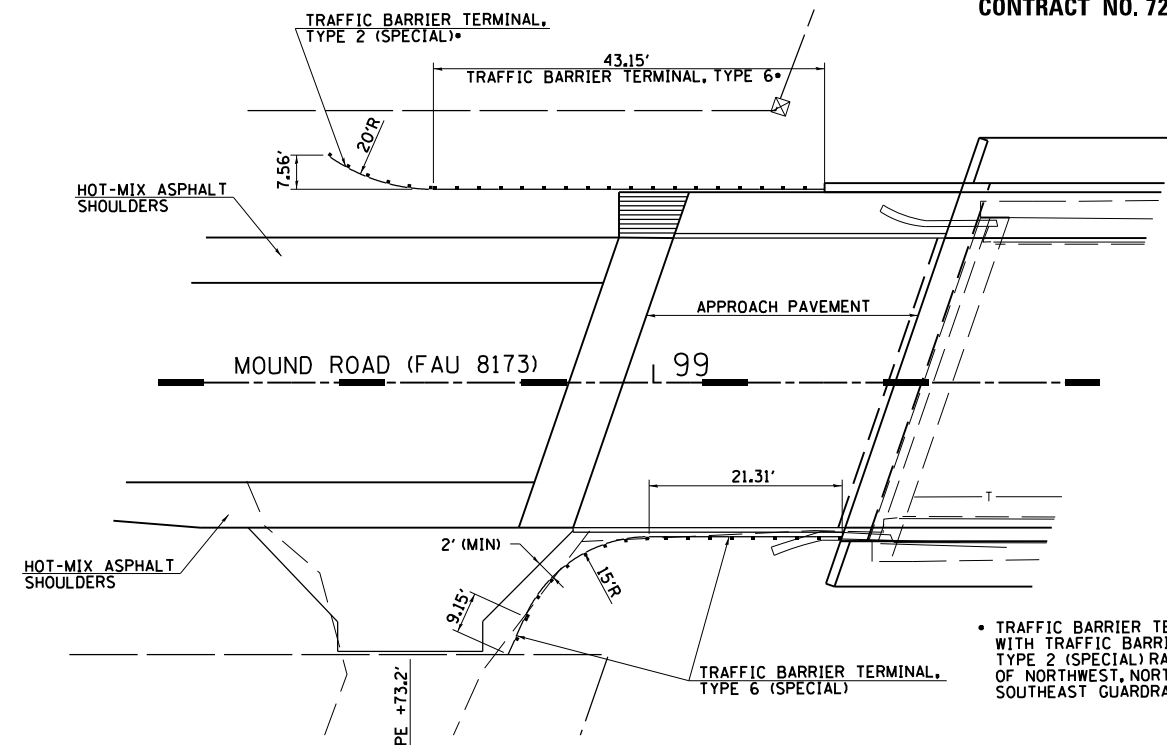

DETAIL FOR TRAFFIC BARRIER TERMINALS (SPECIAL)

• TRAFFIC BARRIER TERMINAL, TYPE 6 WITH TRAFFIC BARRIER TERMINAL, TYPE 2 (SPECIAL) RADIUS TYPICAL OF NORTHWEST, NORTHEAST, AND SOUTHEAST GUARDRAILS.

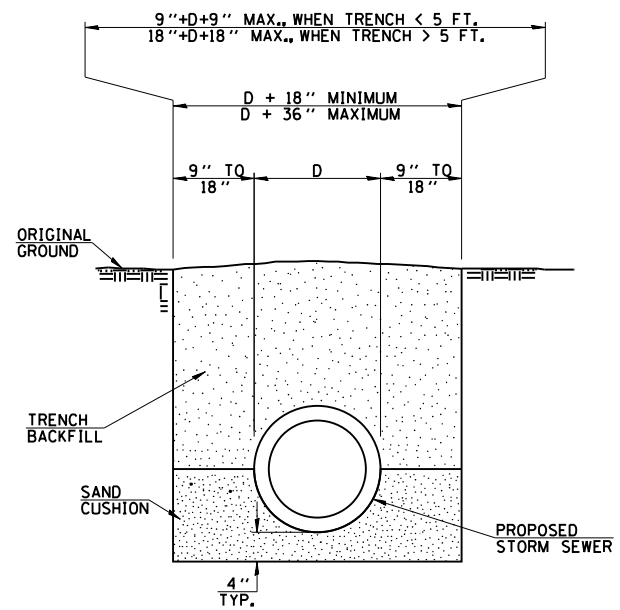

DETAIL OF TRENCH EXCAVATION AND BACKFILL UNDER PROPOSED ROADWAY PAVEMENT AND ENTRANCES

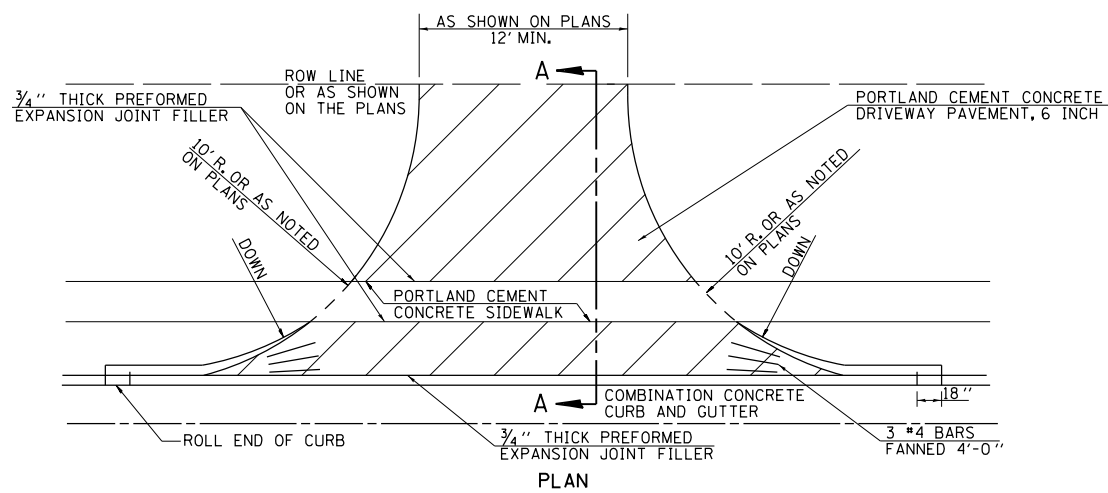

PLAN

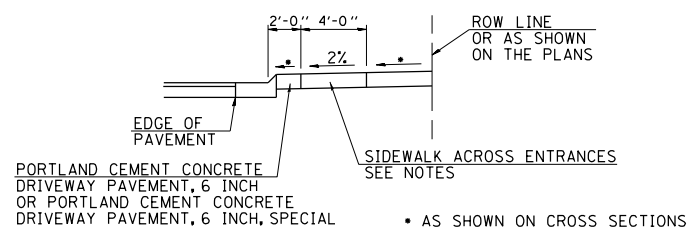

SECTION A-A

ENTRANCE DETAIL

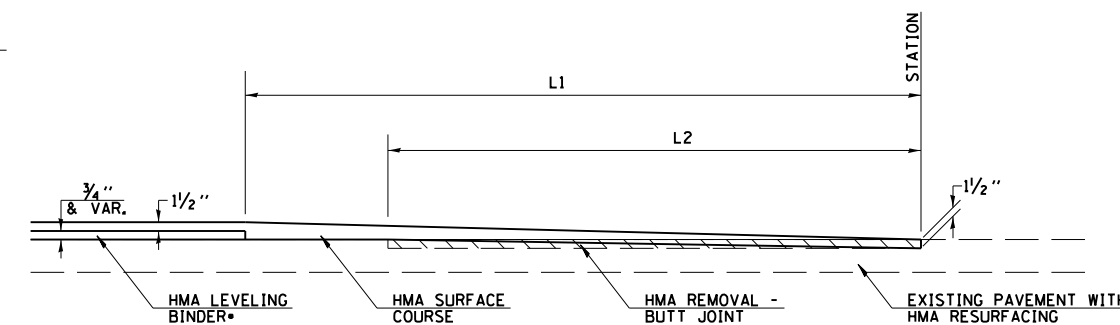

HOT-MIX ASPHALT TAPERS

STATION	L1, FT.	L2, FT.
95+00	90	75
104+40	140	105

• WHEN LEVELING BINDER THICKNESS EXCEEDS 3", HMA CONCRETE BINDER COURSE SHALL BE USED TO BUILD UP RESURFACING THICKNESS TO THE BOTTOM OF THE 2/4" NOMINAL OVERLAY.

REVISIONS	
NAME	DATE

ILLINOIS DEPARTMENT OF TRANSPORTATION

SPECIAL DETAILS

DRAWN BY JCW

CHECKED BY JRB

DATE 10/20/10