

GIRDER ELEVATION

"NTR" denotes plates to which notch toughness requirements are applicable.

SHIM TABLE	
Size	Location
9" x 1'-2" x 1/8"	Girder 4 - N. Abut.
9" x 1'-2" x 1/8"	Girder 3 - S. Abut.

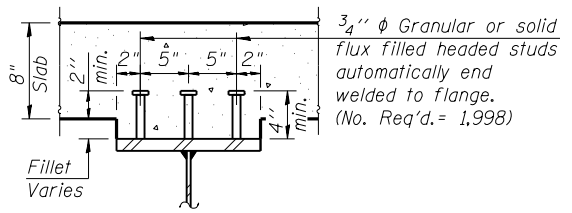

SECTION A-A

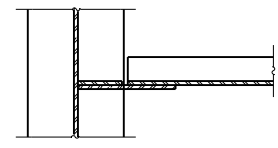

SECTION B-B

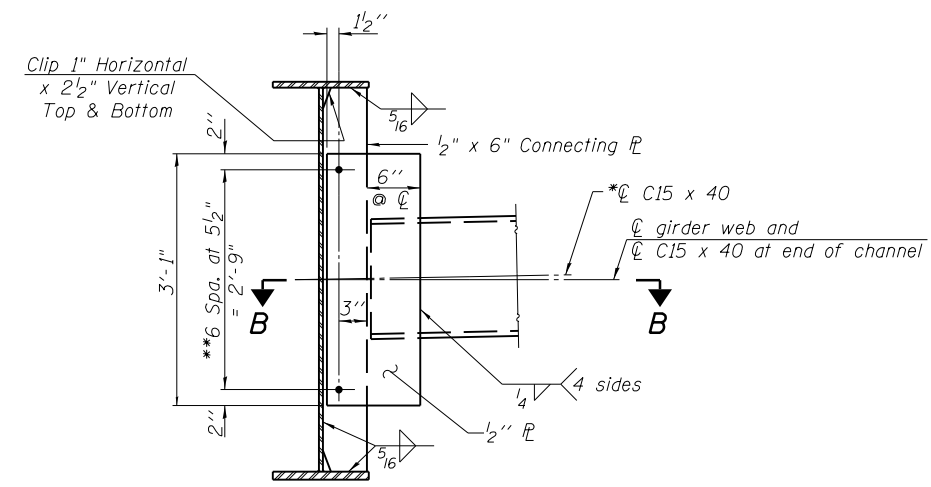

INTERIOR DIAPHRAGM, D
(25 Required)

Notes:
 Two hardened washers required for each set of oversized holes.
 *Alternate C15x50 channels are permitted to facilitate material acquisition.
 Calculated weight of structural steel is based on the lighter section.
 The alternate, if utilized, shall be provided at no additional cost to the Department.
 **3/4" φ HS bolts, 1 5/16" φ holes

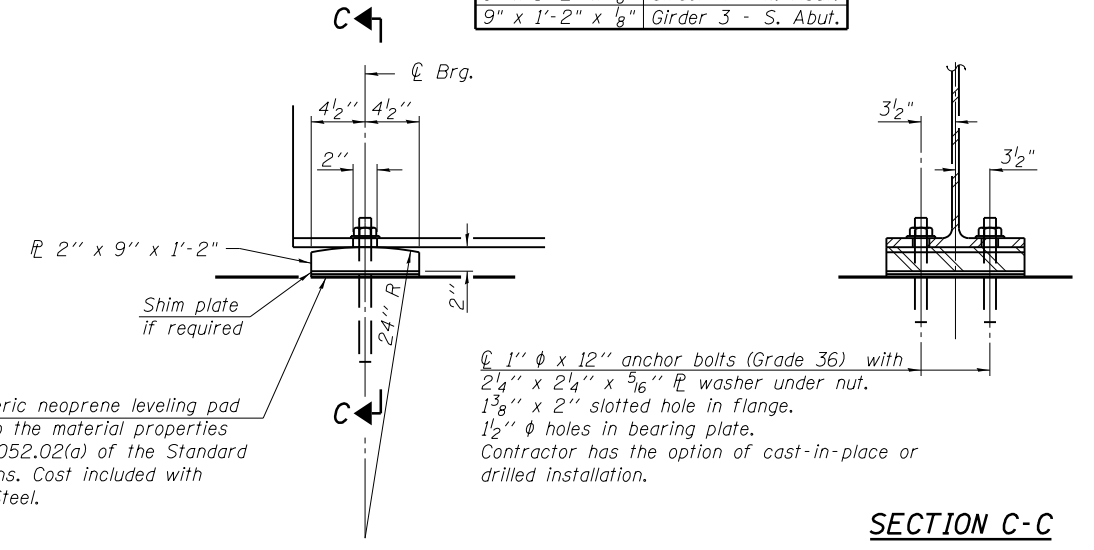

ELEVATION AT ABUTMENT

FIXED BEARING

Notes:
 Load carrying components designated "NTR" shall conform to the Supplemental Requirements for Notch Toughness, Zone 2.
 ***The Contractor shall submit plans showing bracing details for transporting, erection, and deck forming for the section to Engineer for approval.
 Anchor bolts shall be ASTM F1554 all-thread (or an Engineer-approved alternate material) of the grade(s) and diameter(s) specified. ASTM A307 Grade C anchor bolts may be used in lieu of ASTM F1554 Grade 36 (Fy=36ksi). The corresponding specified grade of AASHTO M314 anchor bolts may be used in lieu of ASTM F1554.
 Drilled and set anchor bolts shall be installed according to Article 521.06 of the Standard Specifications.

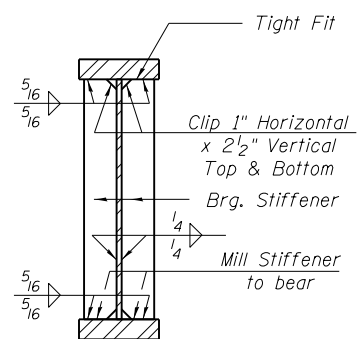

SECTION AT ABUTMENT