

STATE OF ILLINOIS
DEPARTMENT OF TRANSPORTATION

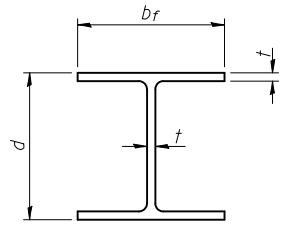

STEEL PILE TABLE

Designation	Depth d	Flange width b _f	Web and Flange thickness t	Encasement diameter A
HP 14x117	14 1/4"	14 7/8"	1 3/16"	30"
x102	14"	14 3/4"	1 1/16"	30"
x89	13 7/8"	14 3/4"	5/8"	30"
x73	13 5/8"	14 5/8"	1/2"	30"
HP 12x84	12 1/4"	12 1/4"	1 1/16"	24"
x74	12 1/8"	12 1/4"	5/8"	24"
x63	12"	12 1/8"	1/2"	24"
x53	11 3/4"	12"	7/16"	24"
HP 10x57	10"	10 1/4"	9/16"	24"
x42	9 3/4"	10 1/8"	7/16"	24"
HP 8x36	8"	8 1/8"	7/16"	18"

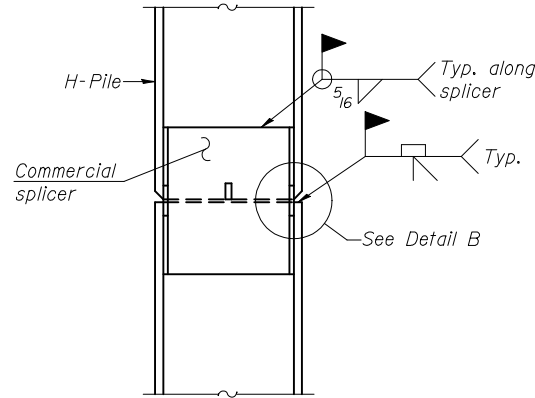

ELEVATION

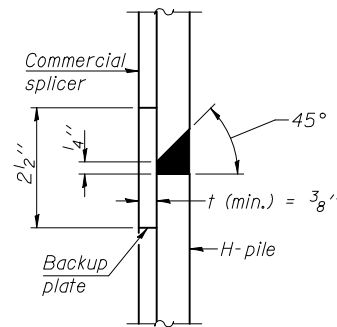

DETAIL "B"

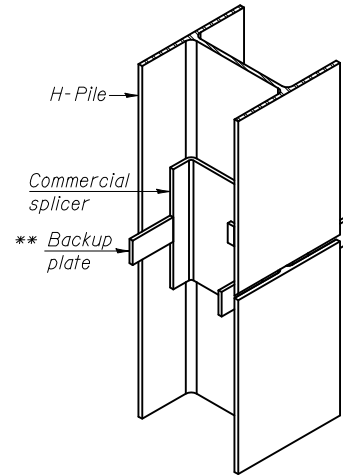

ISOMETRIC VIEW

WELDED COMMERCIAL SPLICE

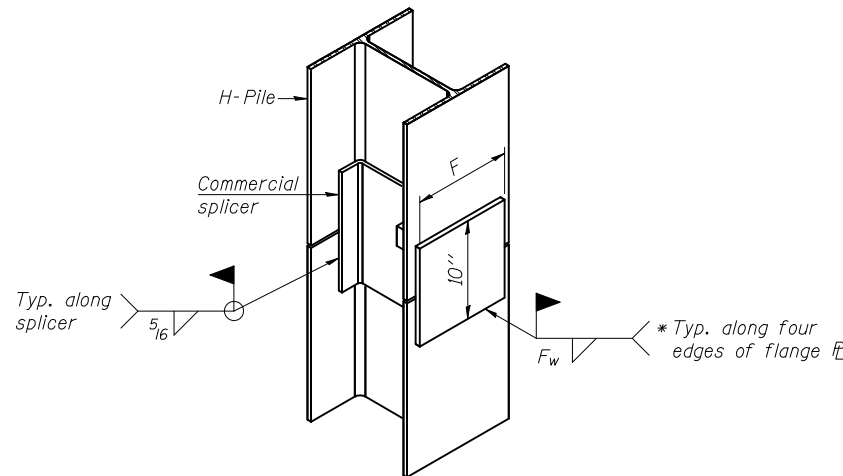

ISOMETRIC VIEW

WELDED COMMERCIAL SPLICE ALTERNATE

- * Interrupt welds 1/4" from end of web and/or each flange.
- ** Remove portions of backup plates that extend outside the flanges.
- *** Weld size per pile shoe manufacturer (5/16" min.).

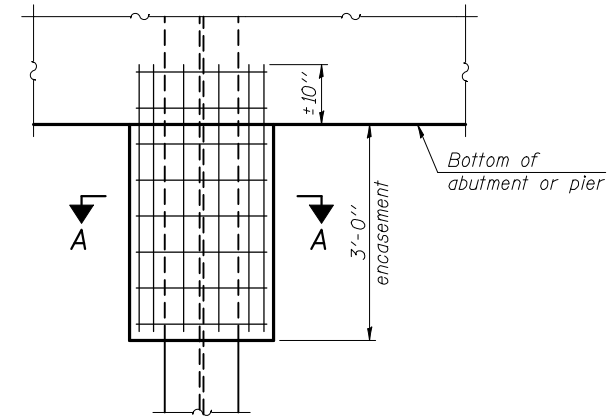

ELEVATION

PILE ENCASEMENT

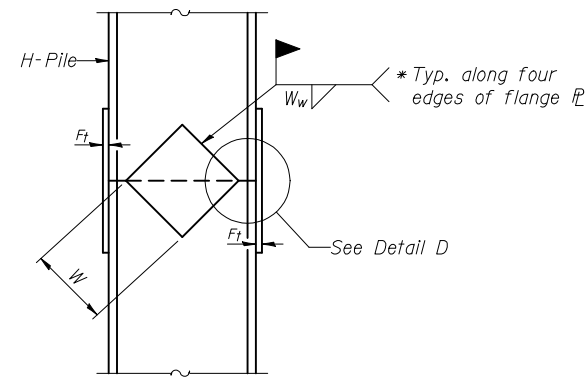

ELEVATION

DETAIL D

WELDED PLATE FIELD SPLICE

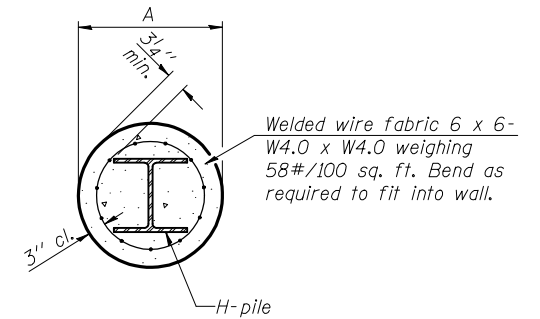

Note:
Forms for encasement may be omitted when soil conditions permit.

SECTION A-A

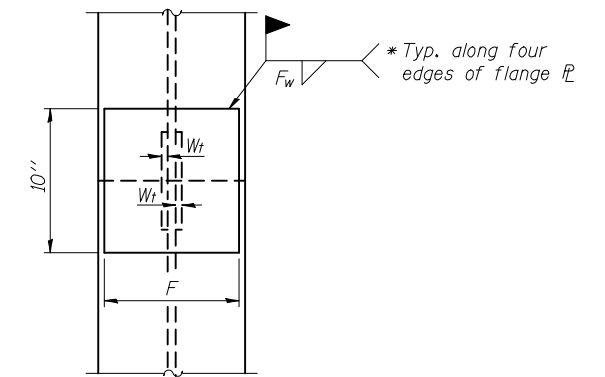

END VIEW

Designation	F	F _t	F _w	W	W _t	W _w
HP 14x117	12 1/2"	1"	7/8"	7 3/4"	5/8"	1/2"
x102	12 1/2"	7/8"	3/4"	7 3/4"	5/8"	1/2"
x89	12 1/2"	3/4"	1 1/16"	7 3/4"	5/8"	1/2"
x73	12 1/2"	5/8"	9/16"	7 3/4"	5/8"	1/2"
HP 12x84	10"	7/8"	1 1/16"	6 1/2"	5/8"	1/2"
x74	10"	7/8"	1 1/16"	6 1/2"	5/8"	1/2"
x63	10"	5/8"	1/2"	6 1/2"	1/2"	3/8"
x53	10"	5/8"	1/2"	6 1/2"	1/2"	3/8"
HP 10x57	8"	3/4"	9/16"	5 1/4"	1/2"	3/8"
x42	8"	5/8"	9/16"	5 1/4"	1/2"	3/8"
HP 8x36	7"	5/8"	7/16"	4 1/4"	1/2"	3/8"

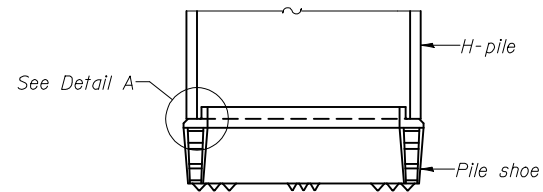

ELEVATION

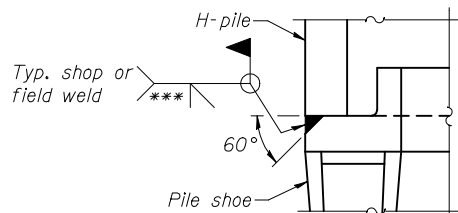

DETAIL A

H-PILE SHOE ATTACHMENT

DESIGNED	Philip E. Coppernoll
CHECKED	Justin T. Belue
DRAWN	h.t. duong
CHECKED	PEC/JTB

F-HP 11-1-09

December 6, 2010

EXAMINED	Thomas J. Domagala
PASSED	Ralph E. Anderson

Note:
The steel H-piles shall be according to AASHTO M270 Grade 50.

SHEET NO. 19 21 SHEETS	F.A.P. RTE.	SECTION	COUNTY	TOTAL SHEETS	SHEET NO.
	745	107B-1	ADAMS	86	53
CONTRACT NO. 72B98					
FED. ROAD DIST. NO. _ ILLINOIS FED. AID PROJECT					

HP PILE DETAILS
STRUCTURE NO. 001-0507