

DeKalb Sanitary District
 303 Hollister Avenue • DeKalb, Illinois 60115
 815.758.3513 Fax: 815.758.6615
 DETAIL No. 20 DATE: 06/12/07 REV: 4

Pavement Replacement Detail
 (City of DeKalb Detail / Specifications)

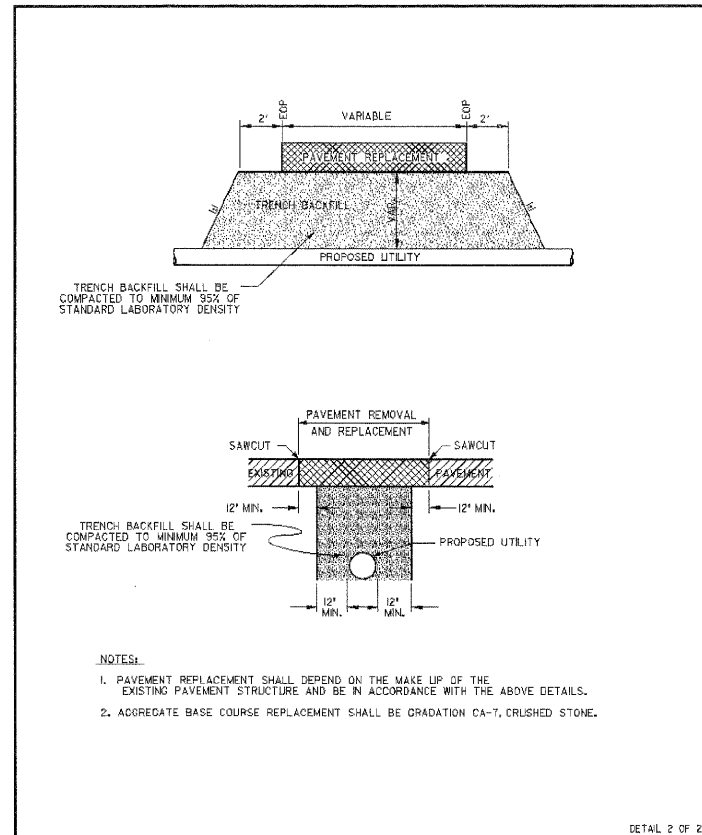

DeKalb Sanitary District
 303 Hollister Avenue • DeKalb, Illinois 60115
 815.758.3513 Fax: 815.758.6615
 DETAIL No. 21 DATE: 06/12/07 REV: 4

Pavement Replacement Detail
 (City of DeKalb Detail / Specifications)

NOTES:
 1. PAVEMENT REPLACEMENT SHALL DEPEND ON THE MAKE UP OF THE EXISTING PAVEMENT STRUCTURE AND BE IN ACCORDANCE WITH THE ABOVE DETAILS.
 2. AGGREGATE BASE COURSE REPLACEMENT SHALL BE GRADATION CA-7, CRUSHED STONE.

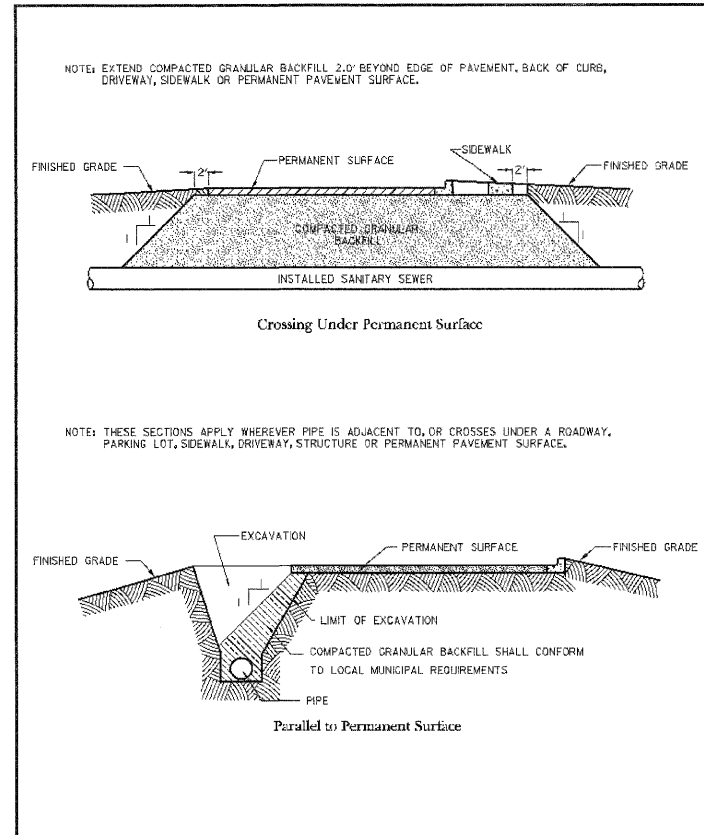

DeKalb Sanitary District
 303 Hollister Avenue • DeKalb, Illinois 60115
 815.758.3513 Fax: 815.758.6615
 DETAIL No. 22 DATE: 06/12/07 REV: 4

Detail for Installation of Pipe
Parallel to and Crossing
Under Permanent Surface

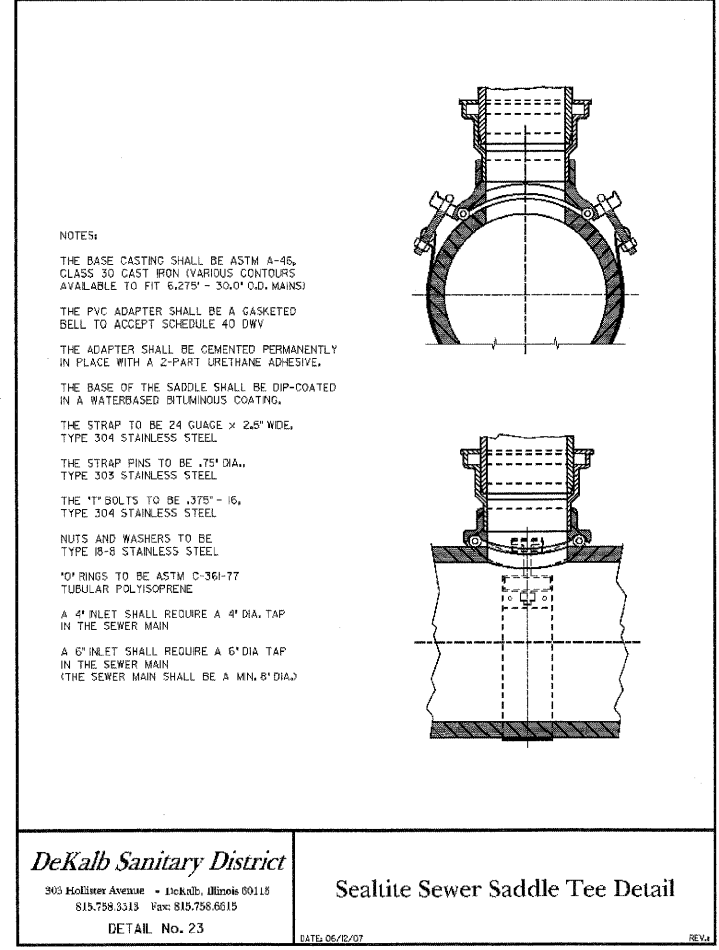

DeKalb Sanitary District
 303 Hollister Avenue • DeKalb, Illinois 60115
 815.758.3513 Fax: 815.758.6615
 DETAIL No. 23 DATE: 06/12/07 REV: 4

Sealite Sewer Saddle Tee Detail

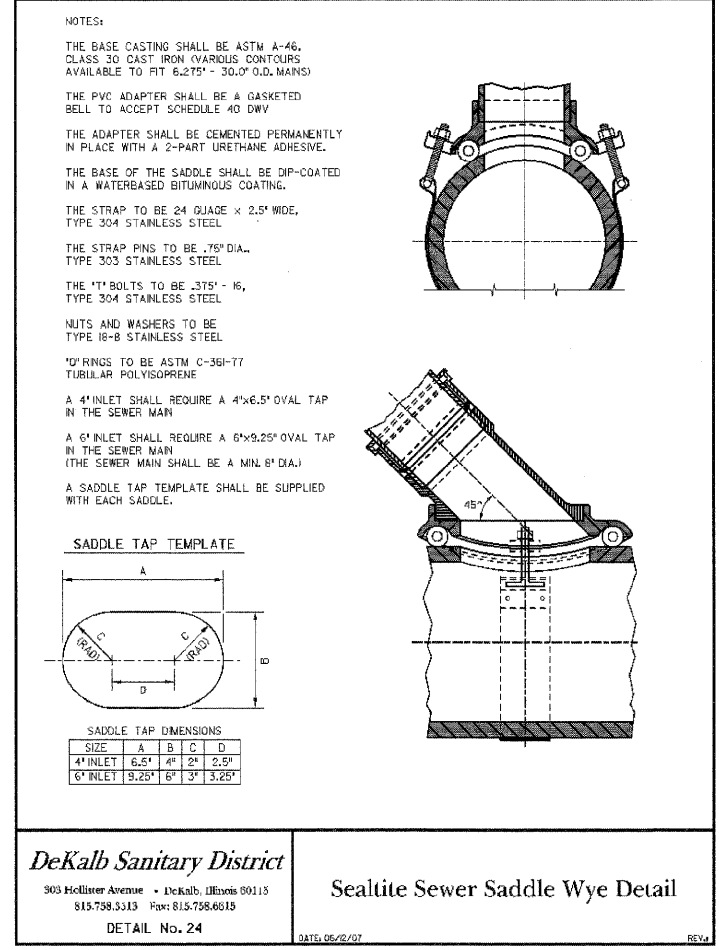

DeKalb Sanitary District
 303 Hollister Avenue • DeKalb, Illinois 60115
 815.758.3513 Fax: 815.758.6615
 DETAIL No. 24 DATE: 06/12/07 REV: 4

Sealite Sewer Saddle Wye Detail

SADDLE TAP DIMENSIONS

SIZE	A	B	C	D
4" INLET	6.5"	4"	2"	2.5"
6" INLET	9.25"	6"	3"	3.25"

Item	Revisions	Date	Copyright

THIS DRAWING SHALL NOT BE USED, REPRODUCED, MODIFIED OR SOLD EITHER WHOLLY OR IN PART, EXCEPT WHEN AUTHORIZED IN WRITING BY THE DEKALB SANITARY DISTRICT.

DeKalb Sanitary District
 303 Hollister Avenue • DeKalb, Illinois 60115
 815.758.3513 Fax: 815.758.6615

Standard Sanitary Sewer Construction Details
DeKalb, Illinois