

EXISTING TYPICAL SECTION

WB NORTH AVE TO WB FAI 290 STA 20+36.49 TO STA 24+00
 WB FAI 290 TO WB NORTH AVE STA 3+00 TO STA 9+74.73
 WB NORTH AVE TO EB FAI 290 STA 0+00 TO STA 7+45.09
 WB FAI 290 AVE TO EB LAKE ST STA 8+00 TO STA 24+10
 EB LAKE ST TO WB FAI 290 STA 0+00 TO STA 6+10.11

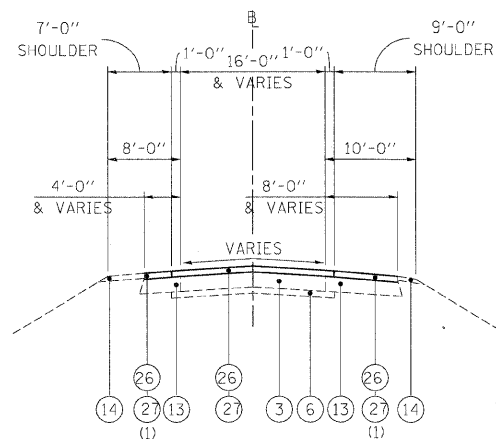

PROPOSED TYPICAL SECTION

WB NORTH AVE TO WB FAI 290 STA 20+36.49 TO STA 24+00
 WB FAI 290 TO WB NORTH AVE STA 3+00 TO STA 9+74.73
 WB NORTH AVE TO EB FAI 290 STA 0+00 TO STA 7+45.09
 WB FAI 290 AVE TO EB LAKE ST STA 8+00 TO STA 24+10
 EB LAKE ST TO WB FAI 290 STA 0+00 TO STA 6+10.11

(1) APPLIES ONNLY TO NB FAI 290 TO EB LAKE ST EXIT RAMP

LEGEND

- ① EXISTING HMA OVERLAY, VARIES*
- ② EXISTING C.R.C. PAVEMENT, 12"
- ③ EXISTING P.C.C. PAVEMENT, 10"
- ④ EXISTING C.R.C. PAVEMENT, 9"
- ⑤ EXISTING C.R.C. PAVEMENT
- ⑥ EXISTING P.C.C. BASE COURSE
- ⑦ EXISTING STABILIZED SUB-BASE, 4"
- ⑧ EXISTING SUB-BASE GRANULAR MATERIAL, TYPE A
- ⑨ EXISTING PGE WRAPPED IN FABRIC (VARIOUS LOCATIONS)
- ⑩ EXISTING PIPE UNDERDRAIN
- ⑪ EXISTING P.C.C. SHOULDER
- ⑫ EXISTING STABILIZED MEDIAN SURFACE
- ⑬ EXISTING BITUMINOUS SHOULDER
- ⑭ EXISTING AGGREGATE SHOULDER
- ⑮ EXISTING AGGREGATE SHOULDER, TYPE B
- ⑯ EXISTING COMB. CONC. CURB & GUTTER, TYPE M-2.12
- ⑰ EXISTING COMB. CONC. CURB & GUTTER, TYPE M-6.24
- ⑱ EXISTING COMB. CONC. CURB & GUTTER, TYPE B-6.24
- ⑲ EXISTING P.C.C. BARRIER WALL
- ⑳ EXISTING STEEL PLATE BEAM GUARDRAIL
- ㉑ HOT-MIX ASPHALT SURFACE REMOVAL 4"
- ㉒ HOT-MIX ASPHALT SURFACE REMOVAL 3 3/4"
- ㉓ HOT-MIX ASPHALT SURFACE REMOVAL 3/4"
- ㉔ NOT USED
- ㉕ NOT USED
- ㉖ HOT-MIX ASPHALT SURFACE COURSE, MIX "D", N70, 1 1/2"
- ㉗ HOT-MIX ASPHALT BINDER COURSE, IL-19.0, N70, 2 1/4"
- ㉘ NOT USED
- ㉙ PROPOSED SHOULDER RUMBLE STRIP (STD. 642001-01)

NOTES:

1. THE CONTRACTOR SHALL MAINTAIN THE EXISTING CROSS SLOPES.
2. THE EXISTING HMA IN THE FLAG OF THE CURB AND GUTTER SHALL BE REMOVED AND REPLACED AT NO ADDITIONAL COST. THESE COSTS SHALL BE INCLUDED IN THE UNIT PRICES FOR THE VARIOUS MILLING AND RESURFACING OPERATIONS MEASURED TO THE EDGE OF THE SHOULDER.
3. THE COST OF HAND REMOVAL OF HMA SURFACE AROUND CASTINGS SHALL BE INCLUDED IN THE COST OF HMA SURFACE REMOVAL OF THE THICKNESS SPECIFIED.

FILE NAME =	DESIGNED - AJP	REVISED -	benesch	STATE OF ILLINOIS DEPARTMENT OF TRANSPORTATION	TYPICAL SECTIONS I-290 RAMPS		F.A.I. RTL.	SECTION	COUNTY	TOTAL SHEETS	SHEET NO.
...:\p\in-ABC_C4_290_ramp.typ.03.dgn	DRAWN - TMB	REVISED -			290	2009-099BR	COOK/DUPAGE	309	10		
USER NAME = jmojewski	CHECKED - JMM	REVISED -			CONTRACT NO. 60157						
PLOT DATE = 11/13/2009	DATE - 10/16/09	REVISED -			SCALE: N.T.S.	SHEET NO. 5 OF 6 SHEETS	STA. TO STA.	FED. ROAD DIST. NO.	ILLINOIS FED. AID PROJECT		