

SINGLE POST ASSEMBLY EXAMPLES

* Dimensional changes required for varying site conditions shall be approved by the Engineer.

a or a₁ = 6" min. to 2'-0" max. (Approximately 0.2W or 0.2W₁)
 b or b₁ = 3" min. to 4" max
 c or c₁ = 3" min. to 4" max
 e = 0" min. to 6" max
 s = 3'-0" min. to 6'-0" max. (Approximately 0.6W or 0.6W₁)
 v or v₁ = 2'-0" min. to 2'-11" max.

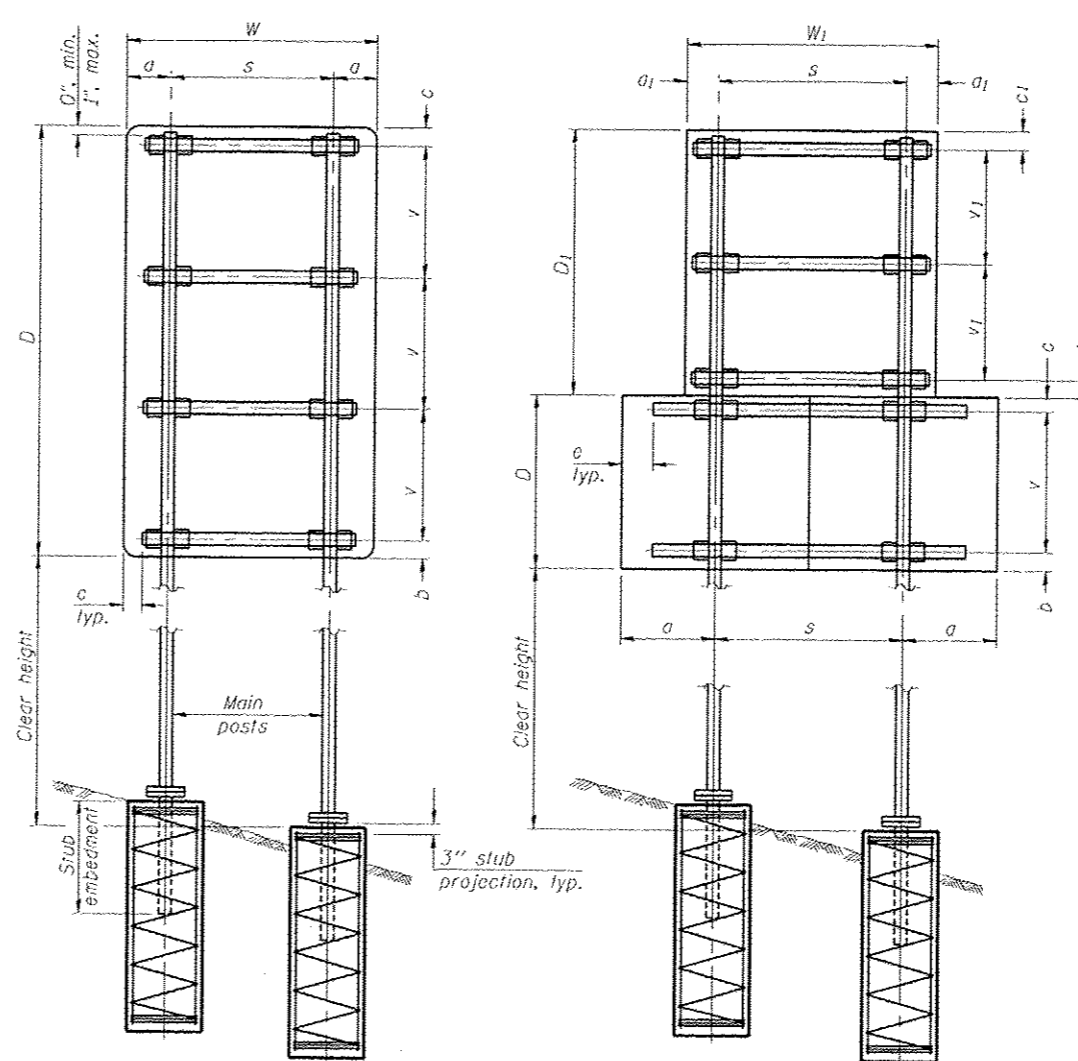

DUAL POST ASSEMBLY EXAMPLES

GENERAL NOTES

Posts shall be plumbed by using shims with post-to-stub post connection bolts snug tight only. Final tightening of all High Strength Bolts shall be in accordance with Article 727.05 and threads at the junction of the bolt and nut shall be burred or center punched to prevent the nut from loosening.

One foundation requires 0.7 cubic yards of concrete and 46 pounds of reinforcement bars and spiral hoops.

LOADING: 80 mph wind with 30% gust factor, normal to sign.

DESIGN STRESSES:
 Structural steel - 20,000 psi
 Reinforcing steel - 20,000 psi
 Concrete - 1,400 psi
 Footing soil pressure - 2,000 psf

After fabrication, the post, fuse plate, base plate and upper 6", min. of the stub post shall be hot-dip galvanized in accordance with AASHTO M111. All bolts, nuts and washers shall be hot-dip galvanized in accordance with AASHTO M232.

For Sections A-A and B-B. see Base Sheet BAT-A-2.

FOUNDATIONS:

All necessary excavation or drilling (except in rock); backfilling with excavated material; disposal of unsuitable or surplus material; formwork; and furnishing and placing the Class SI Concrete and reinforcement bars, shall be included in the pay item used for foundations.

The measurement of the tubular steel shall be computed on the basis of the weight per foot of the support, multiplied by the combined length of the main posts and stub posts.

MAIN POST STEEL TUBING	WEIGHT PER FOOT (POUND)	STUB POST TABLE		MAIN POST TABLE				
		Stub Embedment	Stub Post Length	Bolt Size	A	I	R	Bolt Circle
3" x 2" x 1/4"	7.11	2'-0"	2'-3"	1/2" x 2-3/4"	8 1/4"	5/8"	9/32"	6 1/2"
4" x 2" x 1/4"	8.81	2'-0"	2'-3"	1/2" x 2-3/4"	8 1/4"	5/8"	9/32"	6 1/2"
4" x 3" x 1/4"	10.51	2'-3"	2'-6"	5/8" x 3 1/4"	10"	3/4"	11/32"	8"
5" x 3" x 1/4"	12.21	2'-3"	2'-6"	5/8" x 3 1/4"	10"	3/4"	11/32"	8"
6" x 3" x 1/4"	13.91	2'-3"	2'-6"	5/8" x 3 1/4"	11 1/2"	3/4"	11/32"	9 1/2"
6" x 4" x 1/4"	15.62	2'-3"	2'-6"	3/4" x 3 1/2"	11 1/2"	3/4"	13/32"	9 1/2"
6" x 4" x 5/16"	19.08	2'-3"	2'-6"	3/4" x 3 1/2"	11 1/2"	3/4"	13/32"	9 1/2"
7" x 5" x 1/4"	19.02	2'-6"	2'-9"	3/4" x 3 1/2"	1'-2"	3/4"	13/32"	1'-0"
8" x 4" x 1/4"	19.02	2'-6"	2'-9"	3/4" x 3 1/2"	1'-2"	3/4"	13/32"	1'-0"
8" x 6" x 1/4"	22.42	2'-6"	2'-9"	7/8" x 3 1/2"	1'-2"	3/4"	15/32"	1'-0"

BAT-A-1

6-1-12

(Sheet 1 of 2)

TYLIN INTERNATIONAL USER NAME PLOT SCALE PLOT DATE	DESIGNED DRAWN CHECKED DATE 05/10/2013	REVISED REVISED REVISED REVISED	STATE OF ILLINOIS DEPARTMENT OF TRANSPORTATION	BREAK-AWAY TUBULAR STEEL SIGN POSTS AND FOUNDATIONS	F.A.I. RTE. 57	SECTION 99-IHB-R1	COUNTY WILL	TOTAL SHEETS 679	SHEET NO. 302
	SCALE:	SHEET OF SHEETS			STA. TO STA.	CONTRACT NO. 60L69			