

- NOTES:
1. ALL STEEL ANGLES AND PLATES TO BE GALVANIZED AFTER FABRICATION.
  2. ALL RESTRICTOR PLATES, ANGLES AND HARDWARE TO BE INCLUDED IN THE COST OF THE MANHOLE.
  3. BASIS OF PAYMENT: "MANHOLES, TYPE A, 6 FT. (1.8 m)-DIAMETER, TYPE I FRAME, CLOSED LID, RESTRICTOR PLATE" EACH

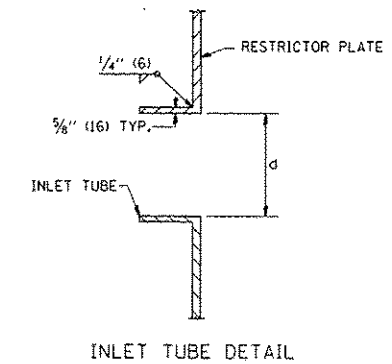

STATION	MANHOLE DIAMETER	FRAME AND GRATE	RESTRICTOR TYPE	INSIDE RESTRICTOR TYPE DIAMETER In. (mm) (d)	INVERT OF RESTRICTOR TYPE	ELEVATION OF TOP OF PLATE OVERFLOW
16023+16.38	5 FT	T 1 CL	4	14 IN	752.50	756.50

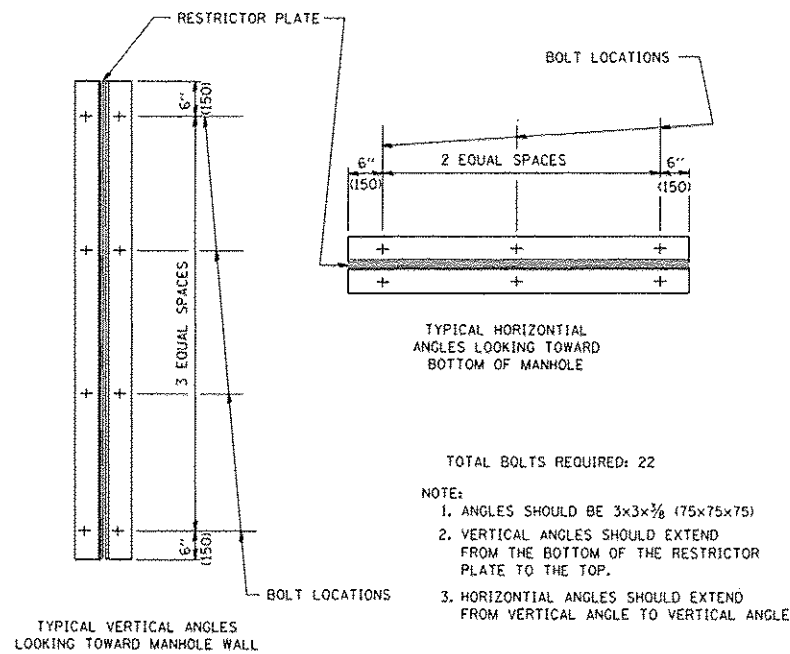

RESTRICTOR TYPE					
1	2	3	4	5	6
RE-ENTRANT TUBE	SHARP EDGED	SQUARE EDGED	RE-ENTRANT TUBE	SQUARE EDGED	ROUNDED
LENGTH: 1/2 TO 1 DIA.		STREAM CLEARS SIDES	LENGTH: 2-1/2 DIA.	LENGTH: 2-1/2 DIA.	
C=.52	C=.61	C=.61	C=.73	C=.82	C=.98
VALUES OF "C" FOR CIRCULAR AND SQUARE ORIFICES					

ALL DIMENSIONS ARE IN INCHES (MILLIMETERS) UNLESS OTHERWISE SHOWN.