

PIER NO. 3 NORTH ELEVATION (LOOKING NORTH)

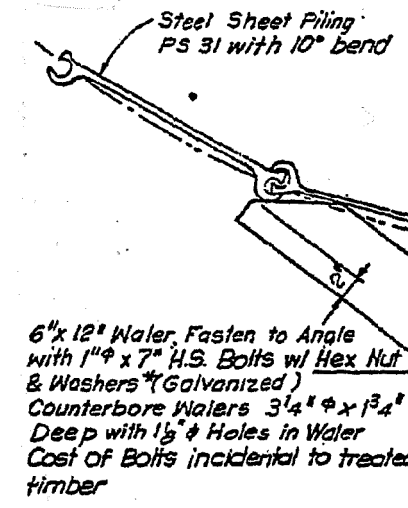

DETAIL B

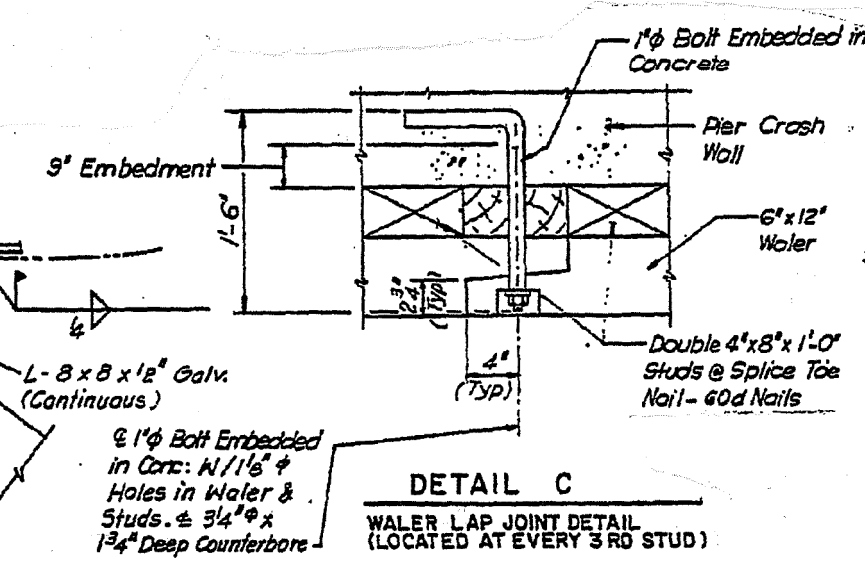

DETAIL C
WALER LAP JOINT DETAIL
(LOCATED AT EVERY 3RD STUD)

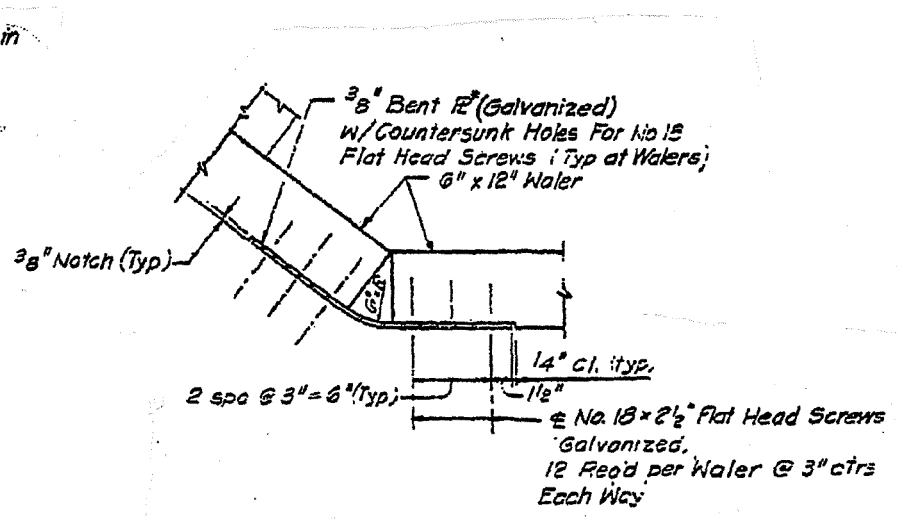

DETAIL D

LEGEND



NOTE

SEE SPECIAL PROVISIONS FOR UNDERWATER INSTALLATION OF TREATED LUMBER

FILE NAME =	USER NAME = hardnettr	DESIGNED - BH; RA	REVISED -	STATE OF ILLINOIS DEPARTMENT OF TRANSPORTATION	LOCATIONS 4-5 BRIDGE REPAIR PLANS		F.A. RTE.	SECTION	COUNTY	TOTAL SHEETS	SHEET NO.			
Default	Plot Scale = 100.0000' / in.	CHECKED - JAM	REVISED -		SCALE:	SHEET 3 OF 3 SHEETS	STA.	TO STA.	VAR.	2013-043BR	COOK	22	22	
	PLOT DATE = 12/11/2013	DATE - 11 /21 /13	REVISED -											