

TYPICAL SECTION THROUGH GUARDRAIL
See Table for Locations

GUARDRAIL BOLT REPLACEMENT LOCATION SUMMARY

SPAN	SIDE	LOCATION	BOLTS MISSING	TOTAL/SPAN
9	East	P.P. 7 - P.P. 6	2	5
9	West	P.P. 7 - P.P. 6	3	
10	West	P.P. 8 - P.P. 7	1	11
10	East	P.P. 8 - P.P. 7	1	
10	West	P.P. 7 - P.P. 6	1	
10	East	P.P. 6 - P.P. 5	2	
10	East	P.P. 4 - P.P. 3	2	
10	East	P.P. 4 - P.P. 3	2	
11	East	P.P. 13 - P.P. 12	1	7
11	East	P.P. 12 - P.P. 11	1	
11	East	P.P. 11 - P.P. 10	1	
11	East	P.P. 3 - P.P. 2	1	
11	West	10' N OF B6	1	
11	West	3' S OF B6	1	
11	West	3' N OF JT.	1	
12	West	P.P. 11 - P.P. 10	3	8
12	West	P.P. 3 - P.P. 2	3	
12	West	13' S OF B2	1	
12	West	P.P. 2 - P.P. 1	1	
13	West	P.P. 8 - P.P. 7	2	2
14	West	25' S of B8	2	2
15	East	6' S of B9	1	1
17	East	6' N of B10	1	1
19	West	6' N of B12	2	8
19	West	9' N of B12	2	
19	East	24' N of B12	1	
19	East	40' N of B12	1	
19	East	20' S of B13	2	
21	West	3' N of B14	1	
21	East	9' N of B14	2	
24	West	5' S OF B18	1	1
TOTAL			49	

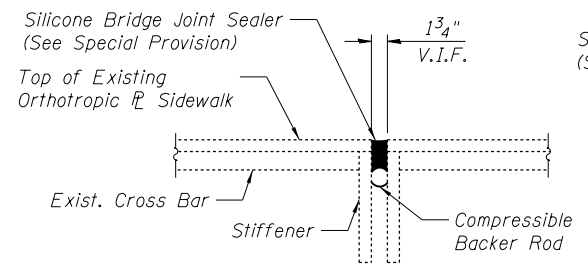

SIDEWALK PANEL JOINT REPAIR DETAIL
Span 10,11 West Sidewalk Joint @ Pier 3

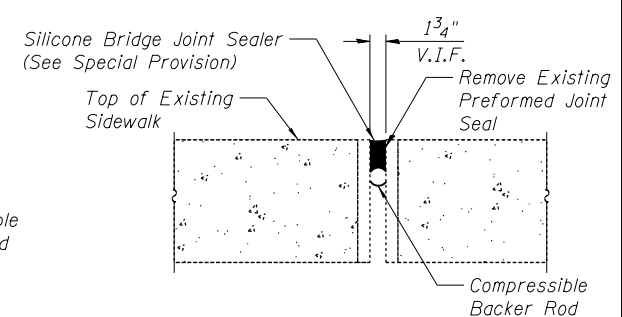

SIDEWALK JOINT REPAIR DETAIL
Span 1, East Sidewalk Joint @ S. Abutment

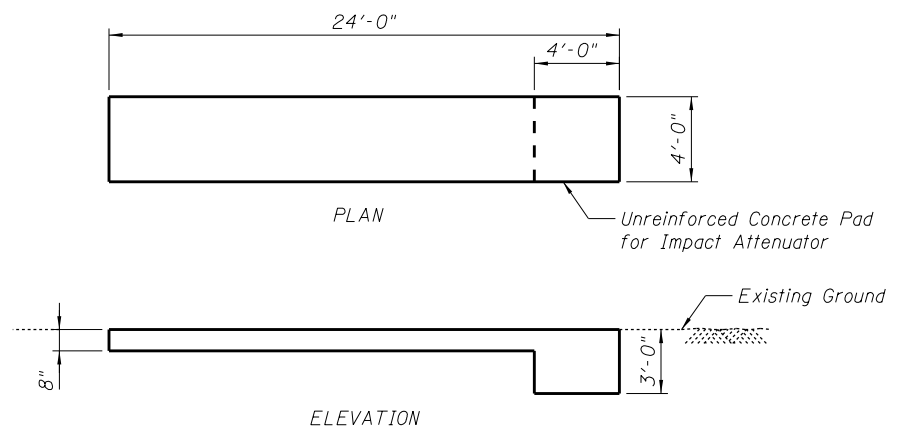

CONCRETE PAD DETAIL

Notes:
Concrete Pad per Manufacturer Recommendation
fc' = 4,000 psi

STRUCTURAL REPAIR OF CONCRETE LOCATION SUMMARY

SPAN	MEMBER	LOCATION	AREA (SQ. FT.)
9,10	Pier 2	Wall	31
		Column	12
10,11	Pier 3	Wall	12
		Column	30
12,13	Pier 5	Cap	6
		Wall	30
		Column	10
13,14	Pier 6	Cap	62
		Column	80
		Wall	200
19,20	Bent 13	Cap	40
21,22	Bent 15	Cap	25
22,23	Bent 16	Wall	25
		Cap	25

Paid for as: Structural Repair of Concrete (Depth Equal To or Less Than 5 in.)

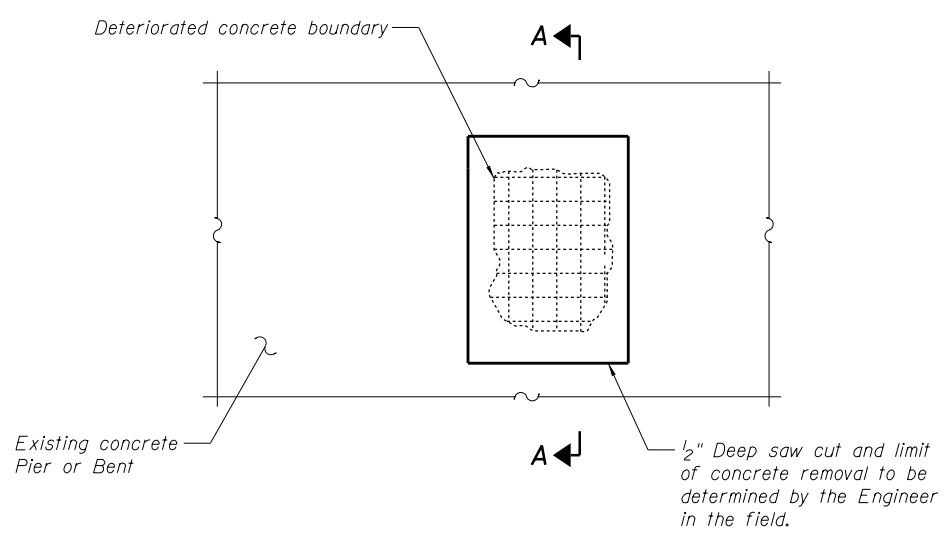

STRUCTURAL REPAIR OF CONCRETE DETAIL

(Depth Equal To or Less Than 5 in.)
See Table for Locations

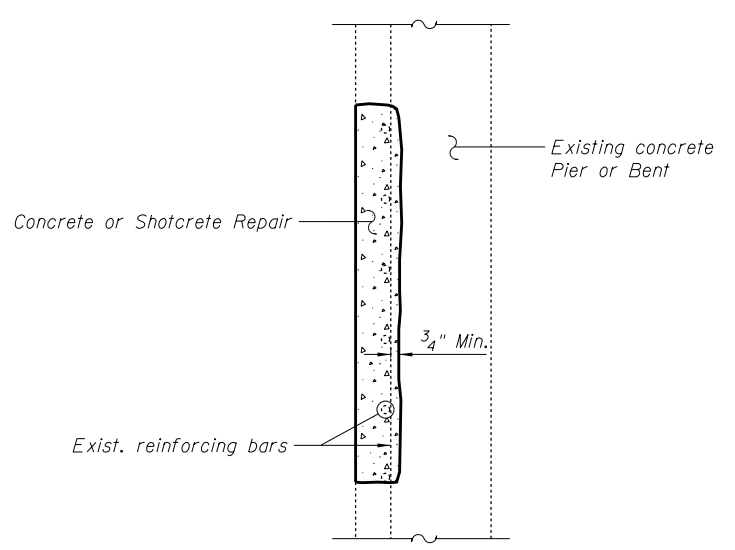

SECTION A-A

FILE NAME = I:\Projects\4015550\4015550_0001\90_CAD_Models_and_Sheets\04_CJ_Bridge\0815085-64H28-019-Miscel\Concrete_Details.dgn



USER NAME = pottrjm	DESIGNED - MJK	REVISED
PLOT SCALE = 2:0.0000 '1' / in.	CHECKED - JAN	REVISED
PLOT DATE = 1/21/2014	DRAWN - JMP	REVISED
	CHECKED - SB	REVISED

STATE OF ILLINOIS
DEPARTMENT OF TRANSPORTATION

MISCELLANEOUS REPAIR DETAILS
STRUCTURE NO. 081-9905

SHEET NO. 24 OF 33 SHEETS

F.A.P. RTE.	SECTION	COUNTY	TOTAL SHEETS	SHEET NO.
308	(3BRM)	ROCK ISLAND	47	37
C-92-090-12		CONTRACT NO. 64H28		
ILLINOIS FED. AID PROJECT				