

HOT-MIX ASPHALT SURFACE REMOVAL – BUTT JOINT

	STATION	TO	STATION	
RAMP I-CA:	(A) 222+07.00		222+12.00	(B)
RAMP I-BD:	(B) 52+55.00		52+60.00	(A)
RAMP I-BC:	(A) 166+70.00		166+75.00	(B)
RAMP I-BC:	(B) 180+45.00		180+50.00	(A)
RAMP I-DB:	(A) 126+70.00		126+75.00	(B)
RAMP I-DB:	(B) 141+85.00		141+90.00	(A)
RAMP I-AC:	(B) 12+31.00		12+36.00	(A)
RAMP I-AD:	(A) 87+00.00		87+05.00	(B)
RAMP I-AD:	(B) 100+51.00		100+56.00	(A)
RAMP I-CB:	(A) 62+00.00		62+05.00	(B)
RAMP I-CB:	(B) 71+77.00		71+82.00	(A)

TYPICAL PROFILE

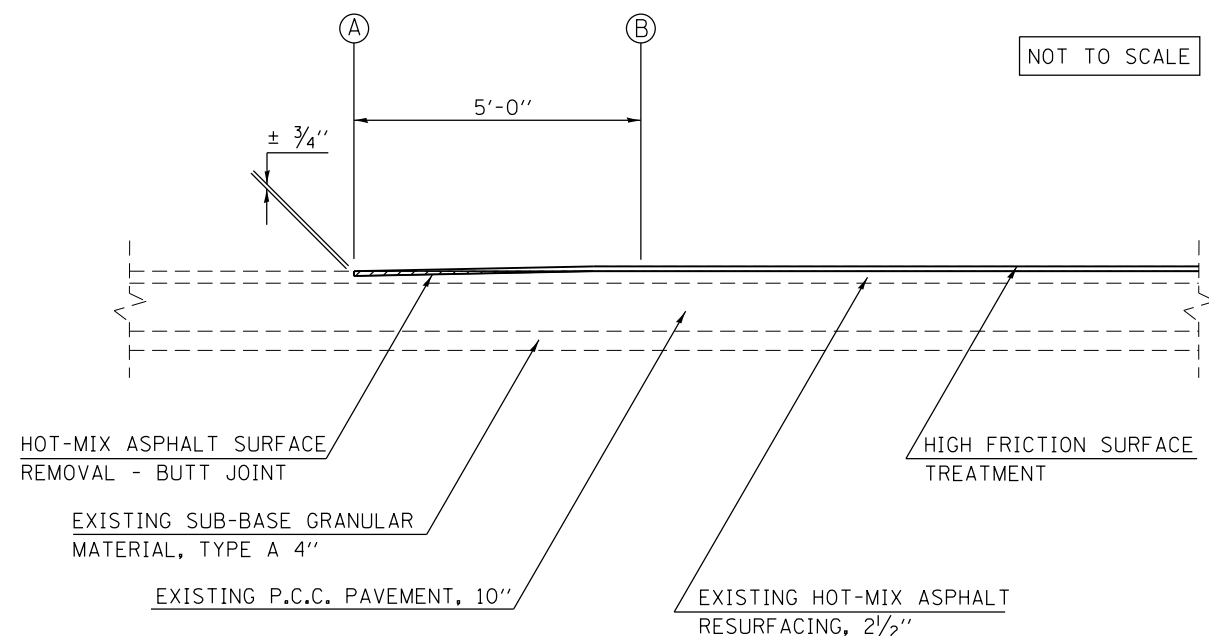

GENERAL NOTES

THE WORK SHALL BE PERFORMED IN ACCORDANCE WITH APPLICABLE ARTICLES OF SECTION 406 OF THE STANDARD SPECIFICATIONS.

THE WORK SHALL BE COMPLETED UNDER RAMP CLOSURE FOR THE HIGH FRICTION SURFACE TREATMENT OPERATIONS.

THE INTENT IS TO INLAY THE HIGH FRICTION SURFACE TREATMENT AT THE BEGINNING AND END OF THE RAMPS TO ALLOW THE MATERIAL TO BE FLUSH WITH THE EXISTING PAVEMENT. ADJUSTMENTS TO THE DEPTH OF THE BUTT JOINT MAY BE REQUIRED TO MEET FIELD CONDITIONS AND WILL BE DETERMINED BY THE ENGINEER.

PORTLAND CEMENT CONCRETE SURFACE REMOVAL – BUTT JOINT

	STATION	TO	STATION	
RAMP I-CA:	(C) 206+70.00		206+75.00	(D)
RAMP I-BD:	(C) 42+06.00		42+11.00	(D)
RAMP I-DA:	(C) 22+00.00		22+05.00	(D)
RAMP I-DA:	(D) 31+65.00		31+70.00	(C)
RAMP I-AC:	(C) 2+20.00		2+25.00	(D)

TYPICAL PROFILE

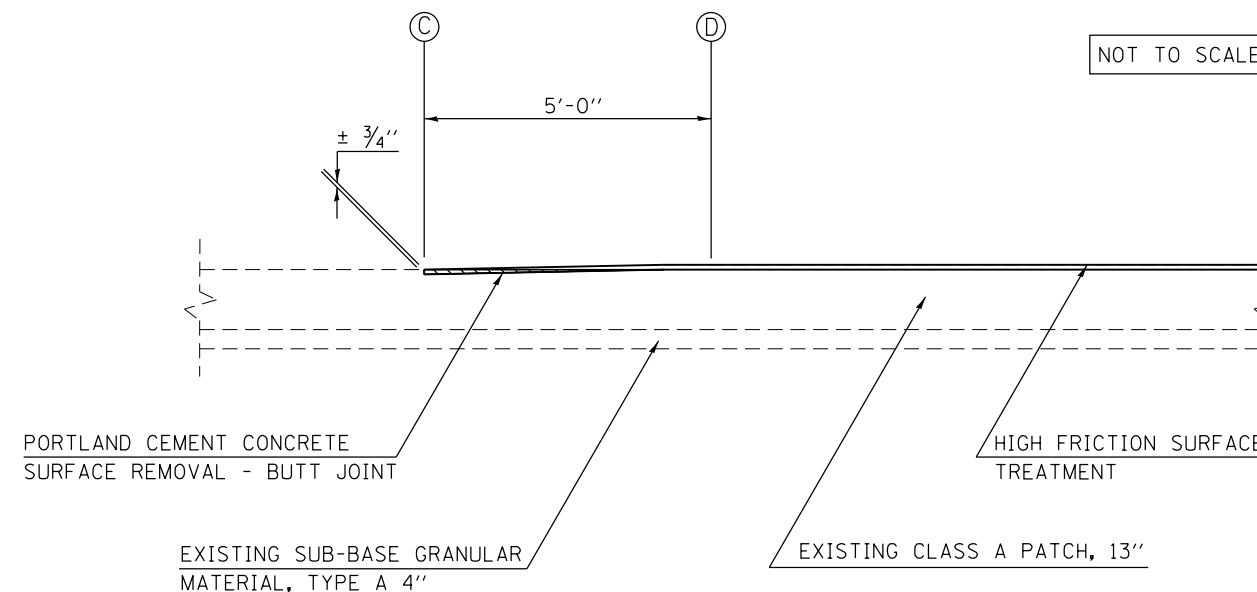

GENERAL NOTES

THE WORK SHALL BE PERFORMED IN ACCORDANCE WITH APPLICABLE ARTICLES OF SECTION 406 OF THE STANDARD SPECIFICATIONS.

THE WORK SHALL BE COMPLETED UNDER RAMP CLOSURE FOR THE HIGH FRICTION SURFACE TREATMENT OPERATIONS.

THE INTENT IS TO INLAY THE HIGH FRICTION SURFACE TREATMENT AT THE BEGINNING AND END OF THE RAMPS TO ALLOW THE MATERIAL TO BE FLUSH WITH THE EXISTING PAVEMENT. ADJUSTMENTS TO THE DEPTH OF THE BUTT JOINT MAY BE REQUIRED TO MEET FIELD CONDITIONS AND WILL BE DETERMINED BY THE ENGINEER.

FILE NAME =	USER NAME = eaglino	DESIGNED - GAE	REVISED -
ci:\pw\work\p\dot\ea\lino\d0363405\0570452-sht-details.dgn		DRAWN - GAE	REVISED -
	PLOT SCALE = 40.0000' / in.	CHECKED -	REVISED -
\$MODELNAME\$	PLOT DATE = 12/6/2013	DATE -	REVISED -

STATE OF ILLINOIS
DEPARTMENT OF TRANSPORTATION

DETAIL FOR HMA & PCC
SURFACE REMOVAL – BUTT JOINT

SCALE: SHEET 1 OF 1 SHEETS STA. TO STA.

F.A.I. RTE.	SECTION	COUNTY	TOTAL SHEETS	SHEET NO.
57	HFSC 2014-1	CHAMPAIGN	31	27
CONTRACT NO. 70A52			ILLINOIS FED. AID PROJECT	