

SIGNAGE SCHEDULE

SIGN #	SIDE	NEW SIGN LEGEND	WHITE WITH BLACK OUTLINE ON RED BACKGROUND	BLACK LEGEND ON YELLOW BACKGROUND	YELLOW LEGEND ON BLACK BACKGROUND	NUMBER OF CHARACTERS	NEW POWER CIRCUIT	NOTES
1	NE SW	B 16	16		B	3	RWY 16/34	NEW SIGN
2	N S	← B		← B		2	RWY 16/34	NEW SIGN
3	N S	A →		A →		2	RWY 16/34	NEW SIGN
4	N S	← A		← A		2	RWY 16/34	NEW SIGN
5	N S	21-3	21-3			4	RWY 3/21	NEW SIGN
6	NE SW	34-16	34-16			5	RWY 16/34	NEW SIGN
7	N S	3-21	3-21			4	RWY 3/21	NEW SIGN
8	N S	D →		D →		2	RWY 16/34	NEW SIGN
9	E W	D 34	34		D	3	RWY 16/34	NEW SIGN
10	NW SE	34 ↑ D 3-21	3-21	34 ↑	D	5	RWY 3/21	NEW SIGN (ADD. ALT. 1)

AIRFIELD SIGN NOTES

1. TRANSFORMER WATTAGE SHALL BE AS REQUIRED BY SIGN MANUFACTURER.
2. SIGN LEGEND SHALL BE AS SHOWN IN THE PLANS.
3. SIGNS SHALL BE SIZE 2, STYLE 2 OR 3, CLASS 2.
4. SEE "NEW BASE MOUNTED EDGE LIGHT" DETAIL FOR GROUNDING DETAILS.
5. RUNWAY DISTANCE REMAINING SIGNS SHALL BE SIZE "X" SIGNS.

NOTES

1. SIGN SCHEDULE MAY BE SUBJECT TO FAA APPROVAL OF THE SIGNAGE PLAN.
2. CHANGES TO NEW LEGENDS MAY OCCUR SUBJECT TO 1 ABOVE.
3. CONTRACTOR SHALL SUBMIT SHOP DRAWINGS WITH NEW LEGENDS FOR APPROVAL PRIOR TO STARTING MANUFACTURE.
4. EXISTING SIGNS ARE LUMACURVE.
5. RUNWAY 3/21 CIRCUIT IS A STYLE 3 CIRCUIT. ALL OTHER SIGNS NOT INSTALLED ON THE RUNWAY 3/21 CIRCUIT SHALL BE STYLE 2.

VE049

REVISIONS

NUMBER	BY	DATE

0 1 2
 THIS BAR IS EQUAL TO 2"
 AT FULL SCALE (34X22).

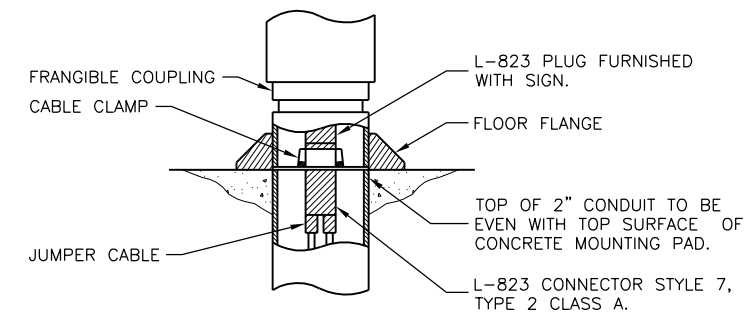
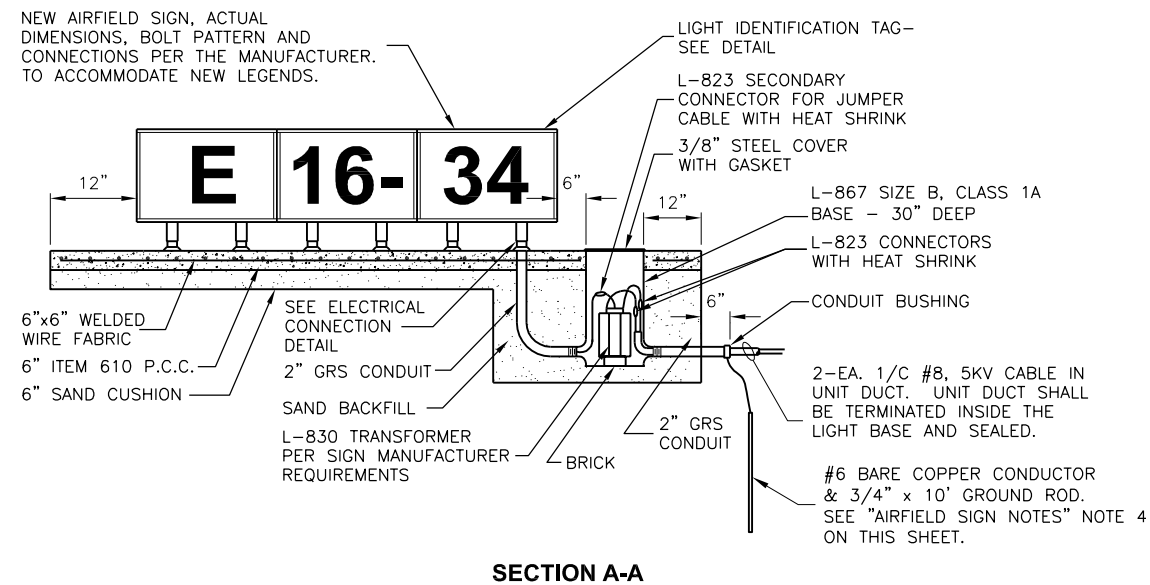
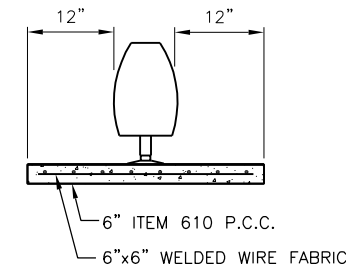
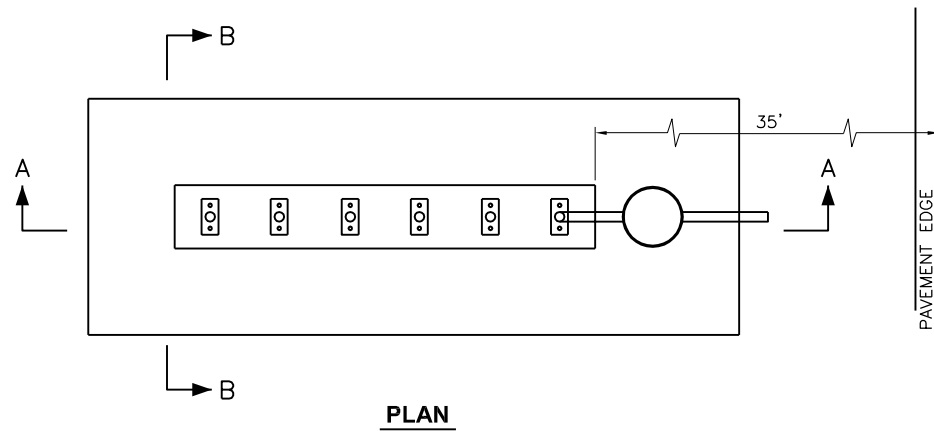

L-858 AIRFIELD SIGN DETAILS

N.T.S.

VERMILION REGIONAL AIRPORT AUTHORITY
 VERMILION REGIONAL AIRPORT
 DANVILLE, ILLINOIS

REHABILITATE LIGHTS ON RUNWAY 16/34
 SIGN DETAIL AND SCHEDULE

© Copyright CMT, Inc.
CMT
 CRAWFORD, MURPHY & TILL, INC.
 CONSULTING ENGINEERS
 License No. 184-000613

DESIGN BY: TJH
 DRAWN BY: CMT
 CHECKED BY: AJB
 APPROVED BY: CET
 DATE: JANUARY 3, 2014
 JOB No: 13042-01
 IL. PROJ. NO. DNV-4234
 PROJ. NO. 3-17-SBGP-XX
 SHEET 14 OF 14 SHEETS