

F.A.I. RTE.	SECTION	COUNTY	TOTAL SHEETS	SHEET NO.
57	(10-30)RA-1-2	CHAMPAIGN	119	37
STA.		TO STA.		
FED. ROAD DIST. NO.	ILLINOIS	FED. AID PROJECT		

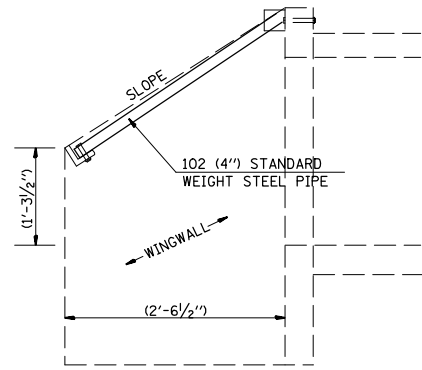

SECTION A-A

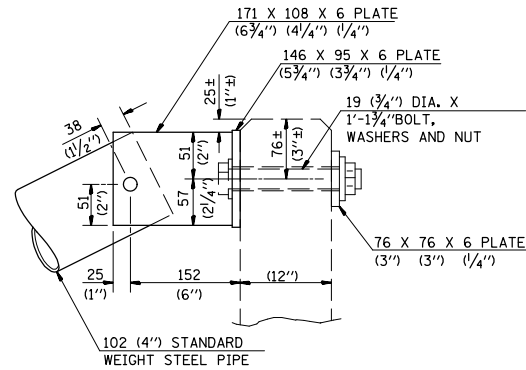

ELEVATION AT HEADWALL

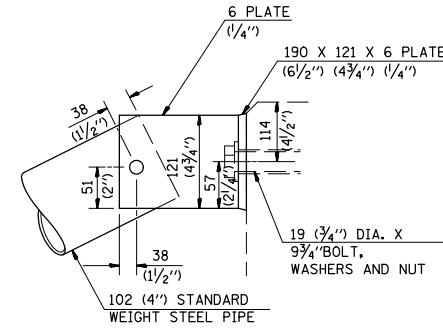

ELEVATION AT WINGWALL

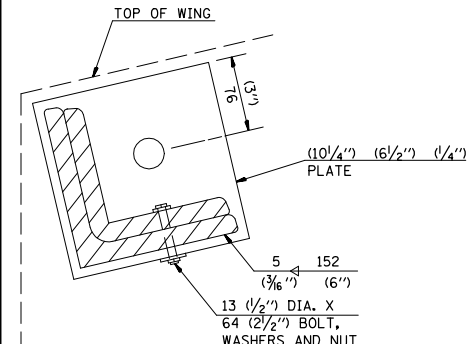

ELEVATION AT END OF WINGWALL

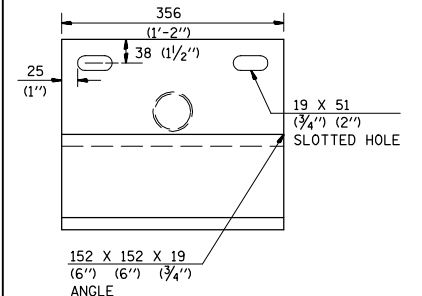

PLAN VIEW OF SUPPORT (IF SPECIFIED)

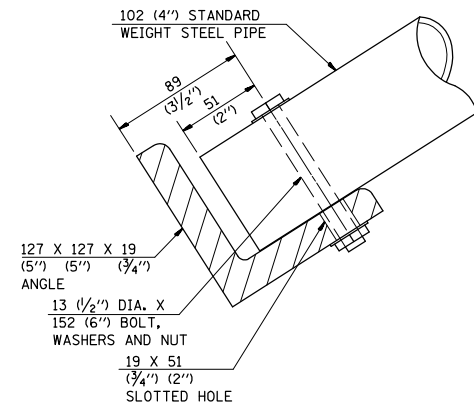

SECTION B-B

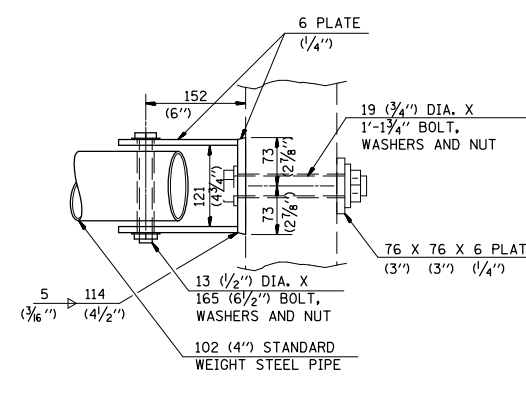

PLAN AT HEADWALL

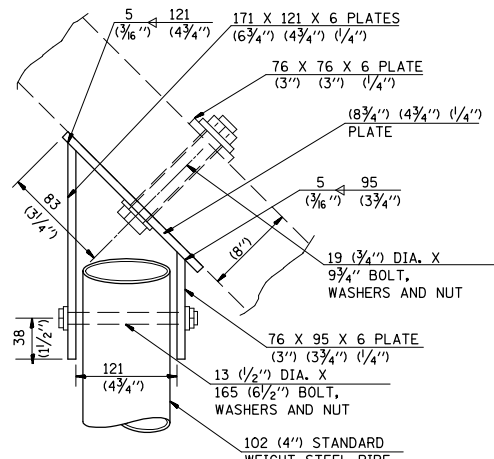

PLAN AT WINGWALL

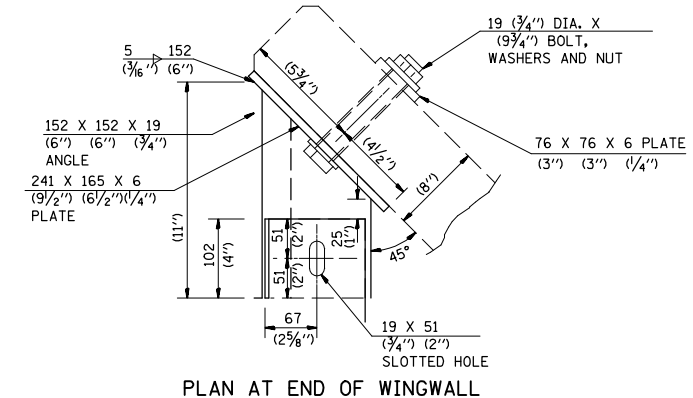

PLAN AT END OF WINGWALL

GENERAL NOTES

- BOLTS AND NUTS SHALL CONFORM TO A.S.T.M. A 307. ALL BOLTS SHALL HAVE WASHERS AT EACH END. HOLES SHALL BE 2 mm (1/16 inch) OVERSIZED UNLESS OTHERWISE NOTED EXCEPT IN CONCRETE WHICH SHALL BE 3 mm (1/8 inch) OVERSIZED.
- ANGLES AND STEEL PLATES SHALL CONFORM TO A.A.S.H.T.O. M 183. STEEL PIPES SHALL CONFORM TO A.S.T.M. A 53, GRADE B OR A.S.T.M. A 501.
- STEEL PIPES, ANGLES AND PLATES SHALL BE HOT DIPPED GALVANIZED CONFORMING TO THE REQUIREMENTS OF A.A.S.H.T.O. M 111.
- BOLTS, NUTS AND WASHERS SHALL BE HOT DIPPED GALVANIZED CONFORMING TO THE REQUIREMENTS OF A.A.S.H.T.O. M 232.
- THE APPROXIMATE WEIGHT OF THE STEEL IS 632 POUNDS. THIS TOTAL INCLUDES PLATES, ANGLES AND PIPES. BOLTS, NUTS AND WASHERS ARE NOT INCLUDED.
- ALL DIMENSIONS ARE TO BE VERIFIED IN THE FIELD. CUTTING OF THE STANDARD WEIGHT PIPE AND ANGLES TO THE EXACT LENGTH AND DRILLING HOLES IS TO BE DONE IN THE FIELD.
- THIS WORK WILL BE PAID FOR AT THE CONTRACT UNIT PRICE EACH FOR "GRATING FOR BOX CULVERT" WHICH PRICE SHALL INCLUDE ALL MATERIAL AND LABOR TO COMPLETE THE INSTALLATION AS SHOWN.

NUMBER OF CENTER SUPPORTS REQUIRED		
W.W. SPAN (TIP-TIP)	NUMBER REQUIRED	SPACING
0' TO 12'-6"	0	-
12'-6" TO 18'-0"	1	CENTER OF W.W. SPAN
OVER 18'-0"	(1 CENTER SUPPORT EVERY ADDITIONAL 6'-0" OF W.W. SPAN)	

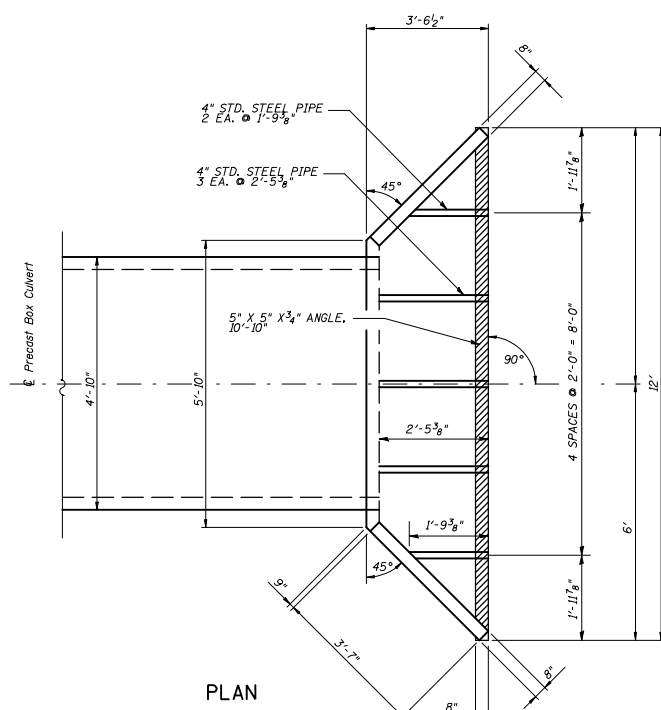

PLAN

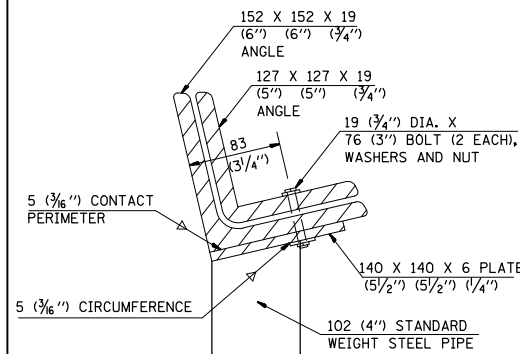

END VIEW OF SUPPORT (IF SPECIFIED)

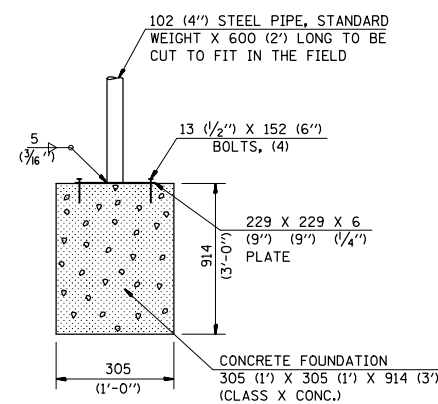

CENTER SUPPORT FOUNDATION (IF SPECIFIED)

GRATING FOR CONCRETE HEADWALL

STATION 211+41.7
0° SKEW

NAME	DATE
DESIGNED	M.A.M. 1-92
REVISED	J.L.M. 7-95
CADD NO.	F-1.83

REVISIONS	
NAME	DATE

ILLINOIS DEPARTMENT OF TRANSPORTATION

GRATING FOR BOX CULVERT DETAIL

SCALE: VERT. NOT TO SCALE
HORIZ. DATE

DRAWN BY
CHECKED BY