

STATE OF ILLINOIS  
DEPARTMENT OF TRANSPORTATION

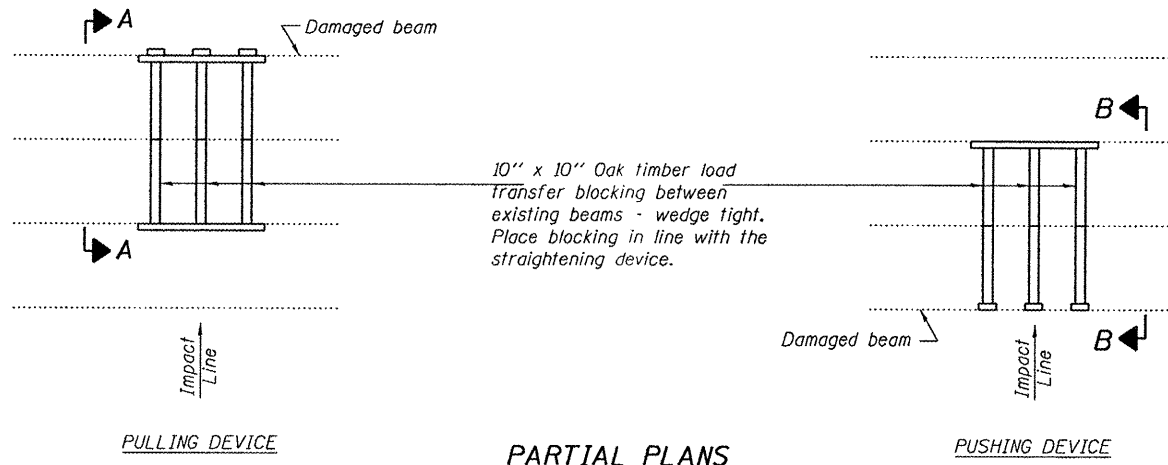

**PARTIAL PLANS**  
**SUGGESTED BEAM STRAIGHTENING METHODS**

Straightening force shall be maintained on all load transfer blocking during beam straightening.

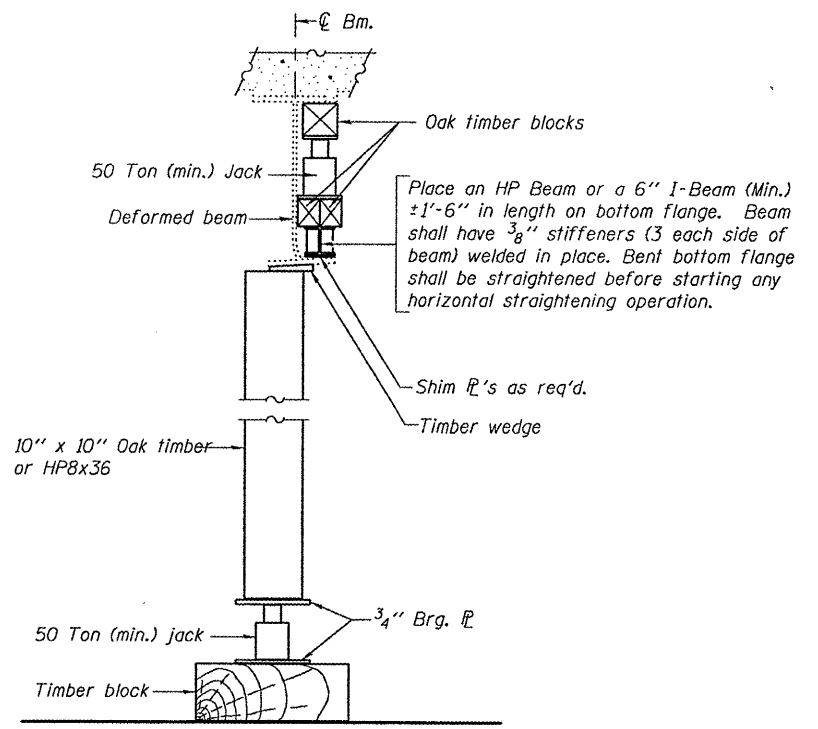

**SUGGESTED VERTICAL STRAIGHTENING DETAIL**  
(To correct flange rotation.)

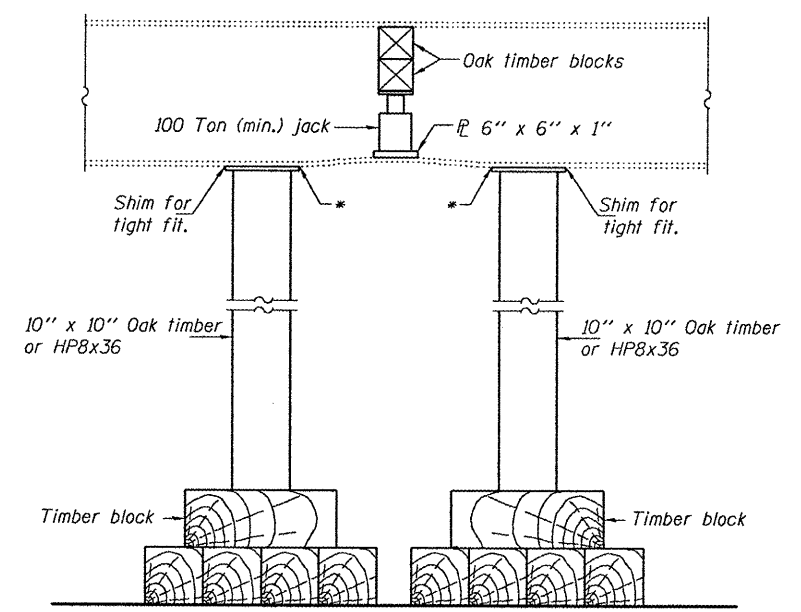

**SUGGESTED VERTICAL STRAIGHTENING DETAIL**  
(To correct localized vertical flange deformations.)

\* Edge of plate shall line up with edge of deformation.

Note:  
Braces and jack assembly shall be placed on same side of web.  
Bent bottom flange shall be straightened before starting any horizontal straightening operations.

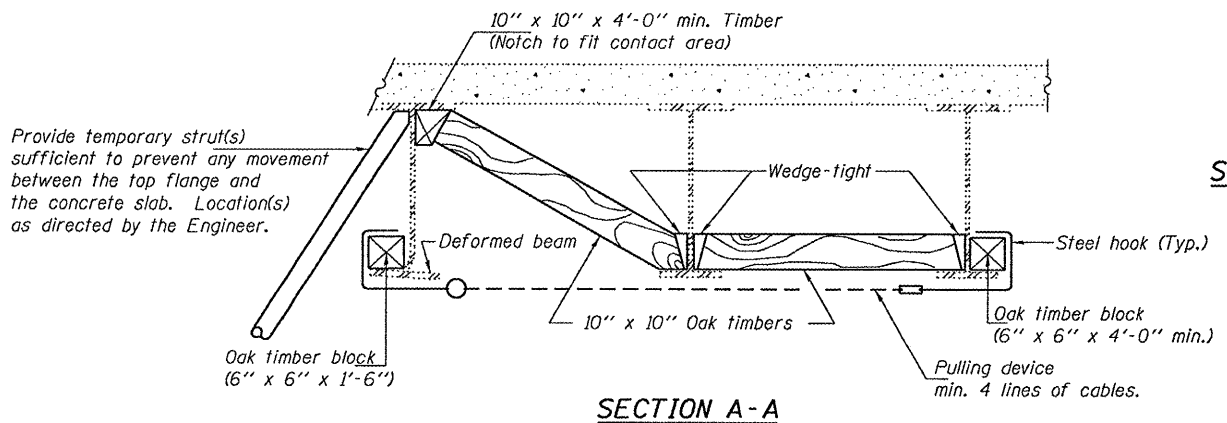

**SECTION A-A**

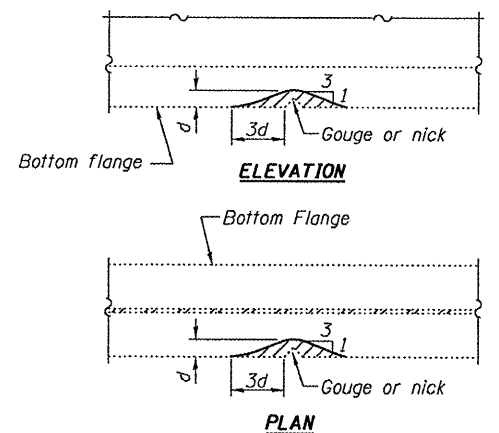

**GRINDING DETAIL**

Grind existing nicks, gouges and shallow cracks in the damaged beams as detailed. Ground surfaces shall be inspected for cracks using magnetic particle testing prior to initiating any beam straightening operations. Any cracks that cannot be removed by grinding approximately 1/4\"/>

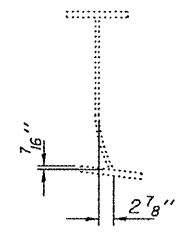

**EXISTING DEFORMATION TO BE STRAIGHTENED**

(Looking South)  
(Approximate max. deflections)  
Deflected length of beam to be straightened is approximately 41'-6\"/>

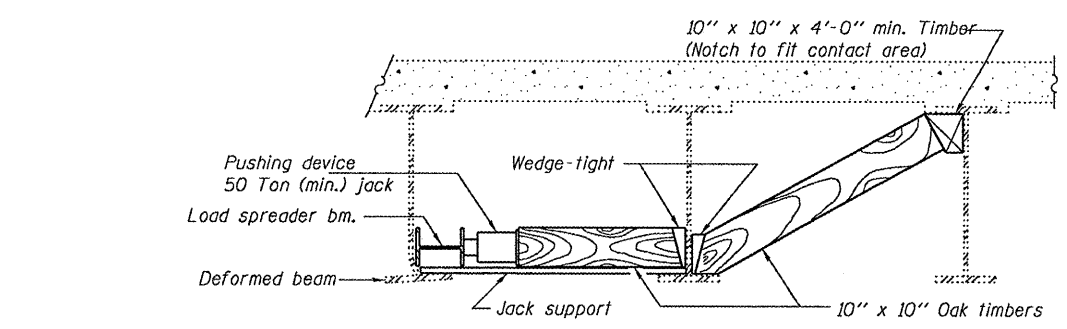

**SECTION B-B**

|          |                 |
|----------|-----------------|
| DESIGNED | ATH             |
| CHECKED  | GGE             |
| DRAWN    | Kyle M. Steffen |
| CHECKED  | ATH / GGE       |

|                  |  |
|------------------|--|
| JANUARY 15, 2010 |  |
| EXAMINED         | <i>Carl Perry</i><br>ENGINEER OF STRUCTURAL SERVICES           |
| PASSED           | <i>Ralph E. Anderson</i><br>ENGINEER OF BRIDGES AND STRUCTURES |

**BEAM STRAIGHTENING DETAILS**  
**I-57 OVER US-45**  
**SN 010-0198**

|                     |             |                            |                    |              |           |
|---------------------|-------------|----------------------------|--------------------|--------------|-----------|
| SHEET NO. 3         | F.A.I. RTE. | SECTION                    | COUNTY             | TOTAL SHEETS | SHEET NO. |
|                     | 57          | (21-28,21-10-29,10-30)RS-1 | CHAMPAIGN          | 115          | 85C       |
| 3 SHEETS            |             |                            | CONTRACT NO. 70251 |              |           |
| FED. ROAD DIST. NO. |             | ILLINOIS FED. AID PROJECT  |                    |              |           |

85C